

12 **EUROPEAN PATENT APPLICATION**

21 Application number: 81300332.4

51 Int. Cl.<sup>3</sup>: **B 26 D 9/00**

22 Date of filing: 26.01.81

30 Priority: 25.01.80 GB 8002523

43 Date of publication of application:  
05.08.81 Bulletin 81/31

84 Designated Contracting States:  
AT BE CH DE FR GB IT LI LU NL SE

71 Applicant: Wood, Clifford Rispen  
303, Hull Road Anlaby Common  
Hull North Humberside HU4 7RY(GB)

72 Inventor: Wood, Clifford Rispen  
303, Hull Road Anlaby Common  
Hull North Humberside HU4 7RY(GB)

74 Representative: Oulton, Richard John et al,  
H.L. Cottrell & Co. 22, Whitefriargate  
Hull. N. Humberside. HU1 2EX.(GB)

54 Manually actuatable combination tools.

57 A combination tool including a number of metal working devices (121 and 123, 126 and 127, 135 and 137, 131 and 133, 134 and 138 and 140) for working wire, rod, bar or sheet materials. The tool is actuated by a single manual lever (118), each metal working device being operable by displacement of said lever in one direction or the other, to effect such metal working operations as cropping, shearing, punching, bending, rolling, and rivetting and, in one form, scroll work. The tool basically comprises a base plate (111), presenting elements of the working tools, a drive member (113), pivotally connected to the base plate and presenting elements of the working tools for co-operation with the elements presented by the base plate, and the hand lever for effecting pivotal displacement of the drive member relative to the base plate to simultaneously work said working devices.

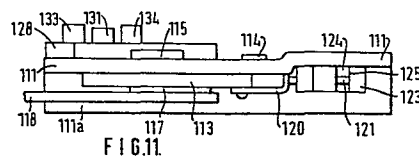
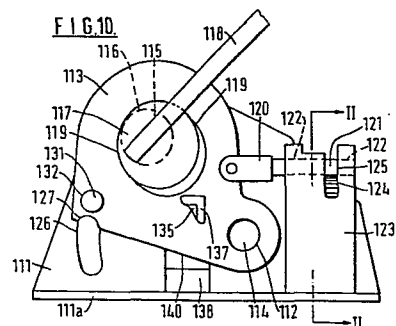

- 1 -

"MANUALLY ACTUABLE COMBINATION  
TOOLS"

"DESCRIPTION"

This invention relates to manually actuatable combination tools, comprising a base plate and a two part metal working device, one part of which is presented by the base plate and the other part is displaceable relative to the base plate via a hand lever.

5 Manually actuatable tools each capable of performing a single metal working operation are well known in the art. A manually operable combination tool is disclosed in British Patent Specification No. 1,066,247 but this disclosure proposes different manual actuating levers for actuating different metal working devices.

10 Thus, when faced with the problems of effecting a plurality of different metal working operations the practitioner must have a separate tool for each operation or the very restricted tool workings afforded by a tool made in accordance with the disclosure of British Patent No. 1,066,247 with its various handles, supplemented by separate tools for performing such metal working functions as cannot be  
15 carried out by the prior art device.

The invention as claimed is intended to provide a remedy to the prior art requirement of a plurality of separate tools. It solves the problem of how to design a combination tool by providing a  
20 manually actuatable combination tool comprising a base plate and a two-part metal working device, one part of which is presented by the base plate and the other part is displaceable relative to the base plate via a hand lever, characterised in that a drive member is pivotally attached to the base plate, a plurality of two-part metal working  
25 devices each have one part presented by the base plate and the other part presented by the said drive member, and the drive member is rotatable relative to the base plate by a single hand lever to effect simultaneous displacement of all the parts of said metal working devices presented by the drive member relative to their co-operating

- 2 -

parts presented by the base plate.

The advantages offered by the invention are thus that a single combination tool can perform a wide range of metal working operations in response to displacement of a single lever. The tool is very much cheaper than the corresponding number of single tools and, by virtue of its price and capability is of particular advantage to the amateur metal worker.

Preferably the hand lever is pivotally attached to said base and includes a cam presenting an edge cam profile, eccentric to the rotational axis for the hand lever, engaged with the drive member, the axis of said cam being spaced from the pivotal axis of the drive member.

In a preferred embodiment the base plate is supported by a frame so as to be pivotally displaceable between two positions substantially at right angles to one another.

Preferably the base plate presents guides for a slide element and said slide element is linked to said drive member, for reciprocation in response to oscillation of said drive member, and said slide element presents one part of a metal working device whilst the base plate presents the other part of the device.

In one preferred embodiment one, or both, parts of selected metal working devices are replaceable by a part or parts of other metal working devices whereby to increase the metal working operations performable by the tool. Such interchanging of devices can greatly increase the versatility of the tool.

Advantageously the base plate and/or the drive member, is adapted to have at least one metal working device attached thereto co-operable with other working devices of the tool to increase the range of metal working operations performable by the tool.

The tool preferably provides devices for performing such common metal working operations as shearing, notching, punching, rolling, and bending, on metal in strip, bar or rod form.

In an advantageous form the tool includes device elements for scroll work conveniently by providing a pivot pin from the base plate and a peg presented by the slide member, the pivot pin serving to support a manually rotatable lever which presents an arcuate member,

- 3 -

rigid with said lever and having a peripheral curvature increasing  
in radius from a slot-like opening intended to receive one end of  
a metal strip, rod or wire therein. A second arcuate member is  
pivotaly attached at one end to that end of said first arcuate  
5 member defining the periphery of the greatest radius and, in that  
position for said second segment closest to the pivotal axis for  
the manually rotatable lever, said second segment present a peri-  
phery which increases in radius from the pivotal connection with the  
first segment in such manner that said two segments, in combination,  
10 present a periphery gradually increasing in radius away from said  
slot-like opening.

Preferably a third arcuate member is pivotaly attached at one end  
to that end of the second member most remote from the first member and,  
when in its closest position to the axis of the manually rotatable  
15 lever, the third arcuate member presents a periphery which increases  
in radius from that end attached to the second segment in a manner  
such that the three arcuate members, in combination, present a sub-  
stantially continuous periphery which increases in radius towards the  
free end of the third segment.

20 In a most preferred form for scroll work said arcuate members are  
detachably secured together and are interchangeable with other arcuate  
members of different curvatures.

Ways of carrying out the invention are described in detail below  
with reference to the drawings which illustrate two specific embodi-  
25 ments and in which:-

Fig. 1 shows a perspective view of a base plate for a combination  
tool with some of the attachments to one side thereof illustrated in  
exploded perspective,

30 Fig. 2 shows in axial view of the manual actuating means for the  
tool,

Fig. 3 shows a side view of the actuating means shown in Fig. 2,

Fig. 4 shows, in exploded view, the attachments to the base plate  
on the reverse side to that illustrated in Fig. 1,

35 Fig. 5 shows a front view of the slider and guide arrangement,  
illustrated in Fig. 4, in assembled condition,

Fig. 6 shows a modified form of the combination tool,

- 4 -

Fig. 7 shows a view of the attachment for scroll work,

Fig. 8 shows an end view of one arrangement for supporting the base plate in one position,

5 Fig. 9 is a view, similar to Fig. 8, with the base plate in its alternative position,

Fig. 10 shows a side view of a second embodiment for a combination tool,

Fig. 11 shows a plan view of the tool illustrated in Fig. 10,

10 Fig. 12 shows a cross-section through the tool on the line II:II in Fig. 10 and,

Fig. 13 shows a side view of the tool from the opposite direction to that of Fig. 10.

In the example illustrated in Figs. 1, 2, 3, 4 and 5, a base plate, generally indicated by reference numeral 11, comprises a tool supporting part 11a with a base part 11b substantially at right angles thereto. The base part 11b conveniently includes two countersunk holes 12 and 13, by which the base may be secured to a work table. The base part 11b also includes two upstanding lugs 14 and 15, with axially aligned bores 14a and 15a, by which the base plate 11 may be supported by a support arrangement, to be described hereinafter, as an alternative arrangement to the securement by screws through holes 12 and 13.

20 The base part 11a includes a bore 16 and a drive member 17 is pivotally attached to part 11a by a screw 18 which passes through a bore 19 in drive member 17 and through bore 16, the screw 18 being secured by a nut 20 on the reverse side of part 11a.

30 The part 11a includes an opening 21 therethrough and the part 11a below opening 21, as viewed in Fig. 1, is deflected away from the plane of the illustrated face to house a shearing block 22 so that the face of block 22 exposed at the illustrated face of part 11a lies in the plane of said face. The block 22 is secured by screws 23 and 24 entering into tapped holes 25 and 26 respectively in part 11a.

35 That part of drive member 17 intended to sweep a path adjacent the shearing block 22 has a configuration (not shown) which co-operates with the shearing block 22 to shear a metal strip or wire passing through the opening 21 when the drive member 17 is rotated anti-

- 5 -

clockwise as viewed in Fig. 1. Thus, the tool affords means for shearing metal in wire, rod, or strip form.

The part 11a further includes a section, generally identified by reference numeral 27, deflected away from the plane of the  
5 illustrated face to partially house a die 28 which is secured to part 11a by two screws 29 and 30 which pass through bores in die 28 and enter respectively into tapped bores 31 and 32 in deflected part 27. The die 28 has a bore 28a passing transversely therethrough and a vertical slot 28b, extending from the upper surface of the die block  
10 downwardly some distance below the axis of the bore 28a.

A punch 33, attached to a yoke 34, is slidably displaceable in bore 28a and the yoke 34 is secured to drive member 17 by a pivot screw 35 which passes through holes 34a in the two arms of the yoke and through a bore 36 in the drive member 17 in such manner that the  
15 two arms of the yoke embrace drive member 17. Thus, on clockwise rotation of the drive member 17 as viewed in Fig. 1, the punch 33 is advanced along bore 28a and can punch a hole through the thickness of a metal strip or plate entered into the slot 28b.

The part 11a includes a slot 37 into which that arm of yoke 34  
20 engaging the side of the drive member 17 adjacent part 11a can project so that the part 11a does not interfere with the movement of yoke 34.

The part 11a further includes a tapped bore 38 by which a platform element 39 may be attached to part 11a by a screw 40 which  
25 passes through a slot 39a in element 39. The element 39 has an open slot intended to receive the die 28 therein so that element 39 can support a metal strip or plate entered into the slot 28b of die 28 and the supporting surface of element 39 can be vertically adjusted to any desired plane below the axis of bore 28a.

Thus, the tool provides a punch device for punching holes in  
30 metal sheet or strip. The drive member 17 is displaced by manually actuated mechanism, generally indicated by reference numeral 41, comprising a hand lever 42 with an annular flange 43, an eccentric 44, and a spindle 45 integral therewith. The spindle 45 passes  
35 through a slot opening 46 in drive member 17 and through a bore 47 in the part 11a, the free end of spindle 45 being threaded and

- 6 -

captive by a nut 48. With the spindle 45 entered into bore 47 and secured by nut 48 the eccentric 44 lies in the slot 46. The flange 43 has a diameter greater than the width of slot 46 whereupon flange 43 assists in retaining drive member 17 in close relationship with part 11a.

5 It will thus be seen that when the mechanism 41 is mounted as described above angular displacement of the hand lever 42 causes rotation of spindle 45 in bore 47, and the eccentric 44 causes pivotal displacement of drive member 17 in a direction dependent upon the direction of displacement of the handle 42.

10 The part 11a includes a vertical slot 49 and, on the reverse face from that illustrated in Fig. 1 (see Fig. 4) a guide element, generally indicated by reference numeral 50, is secured to the part 11a by screws 51, 52, 53 and 54. The guide element is of generally U-shaped configuration comprising parallel limbs 55 and 56 and a bridge part 57, and the upper free ends of the limbs 55 and 56 are connected by a bridge piece 58. The distance between the limbs 55 and 56 is greater than the width of the slot 49, the element 50 is secured to part 11a so that the slot 49 opens between the limbs 55 and 56, and a slide element 59 is slidably disposed between the two limbs 55 and 56 whilst abutting the face of part 11a surrounding the slot 49.

20 A pin 60 passes through a slot 61 in driving member 70 and through the slot 49 for securement, as by threaded engagement, with the slide element 59 whereupon, pivotal displacement of the drive member 17 effects linear displacement of the slide element 59 within the guide element 50.

25 An anvil 62 is screwed into a tapped bore 63 in the bridge part 57 and a hammer 64 is screwed into a tapped bore 65 in the slide element 59 so that, when drive member 17 is rotated in an anticlockwise direction, as viewed in Fig. 1, the slide element 59 is downwardly displaced within the guide element 50 and the hammer 64 approaches anvil 62 and can caulk the head of a rivet between anvil 62 and hammer 64, the axis of the rivet lying in a plane passing through the axis of the anvil 62 and hammer 64.

35 Thus, the tool provides a device for riveting.

- 7 -

The slide element 59 also has a bending block 66 secured thereto by a screw 67 engaged in a tapped bore 68 in element 59, a roller 69 is mounted on a screw 70 secured in a tapped bore 71 in limb 55, and a roller 72 is mounted on a screw 73 secured in a tapped bore 74 in limb 56. The plane passing through the axes of rollers 69 and 72 lies at right angles to the axis of the slide element 59 and thus, by rotating drive member 17 anticlockwise as viewed in Fig. 1, the bending block 66 may be advanced against a strip of wire or plate resting on the rollers 69 and 72 to cause said strip to bend.

In this embodiment the bending block 66 is of cube-like configuration arranged with a plane passing through two opposite corners parallel to the longitudinal direction of the slide element 59 so that the block presents a corner to a wire or plate resting on the rollers 69 and 72 to effect a sharp right angle bend to said wire or strip. However, the bending block 66 may be interchangeable with bending blocks of other form so as to provide, for example, a bend in the wire or plate of desired curvature.

Thus, it will now be appreciated that the tool provides means for bending a metal wire rod or plate. In the modified arrangement illustrated in Fig. 6 the screw 67 is removed, to allow the bending block 66 to be removed, and a knurled roller 75, secured on a hand lever 76, is attached to slide element 59 by the screw 67 which passes, with clearance, through a bore 77 concentric with roller 75 before entering into threaded engagement with the bore 68 in slide element 59. Thus, by angularly displacing hand lever 76, the knurled roller 75 is rotated about the axis of screw 67.

With this arrangement, and with a strip of metal wire rod or plate resting on the rollers 69 and 72, the drive member 17 can be pivotally rotated anticlockwise as viewed in Fig. 1 to lower slide element 59 and thereby engage the knurled roller 75 with said wire, rod, or strip and, by further advancing the drive member 17 the knurled roller 75 will deflect the wire, rod or bar between rollers 69 and 72 and, by then rotating hand lever 76, a desired curvature can be imparted along the length of the metal wire, rod or bar.

Thus, with the attachment illustrated in Fig. 6, the tool provides means for imparting a curvature along the length of a metal

- 8 -

wire, rod or bar.

The mechanism illustrated in Fig. 7 allows a further operation to be performed and, as will be noted, said mechanism comprises a hand lever 78 with an arcuate section 79 secured thereto, a second arcuate section 80 pivotally attached to the free end of the first section 79, and a third arcuate section 81 pivotally attached to that end of the second section 80 remote from the first section 79. The first section 79 presents an abutment face 79a engageable with and abutment face 80a presented by the second section 80 to limit clockwise displacement of the second section 80 relative to the first section 79, and the second section 80 presents an abutment face 80b engageable with an abutment face 81a on the third section 81 to limit clockwise displacement of the third section 81 relative to the second section 80. The first section 79 includes a slot opening 82 and, when the faces 79a and 80a and faces 80b and 81a are in abutting relationship, the sections 79, 80 and 81 present peripheral surfaces 79b, 80c and 81b defining a curvature of increasing radius from the slot 82 towards the free end of element 81 with respect to the axis of a bore 83 passing through the hand lever 78 and the section 69.

The mechanism illustrated in Fig. 7 and described above is attached to the tool by removing the anvil 62 and entering a long screw (not shown) through the bore 83 and into the threaded bore 63 in bridge part 57, the long screw allowing the sections 79, 80 and 81 to lie in planes outwardly of the plane passing through the free ends of rollers 69 and 70. The screw 67 is also removed, to release the bending block 66, and a peg 84 is screwed into the threaded bore 68 in slide element 59 and has such length as to be outstanding from that plane passing through the free ends of rollers 69 and 70.

With the mechanism 78 to 83 mounted on the tool as described above the section 80 can be rotated anticlockwise (as viewed in Fig. 7) relative to section 79 and section 81 can be rotated anticlockwise relative to section 80 (as viewed in Fig. 1) to allow one end of a metal wire, rod, or bar 85 to be entered into the slot 82 when, by rotating the lever 78 anticlockwise (as viewed in Fig. 7) the wire, rod or strip 85 abuts the peg 84, whereupon further anticlockwise

- 9 -

rotation of hand lever 79 causes the wire, rod or bar 85 to be progressively wound onto the peripheral surfaces 79b, 80c and 81b, thus to produce a spiral form. It will be appreciated that as hand lever 78 is rotated the metal, wire, rod or bar 85 will deflect the sections 80 and 81 clockwise (as viewed in Fig. 7) until the abutment faces 79a and 80a are in abutting relationship and the surfaces 80b and 81a are in abutting relationship.

Thus, with the mechanism illustrated in Fig. 7 attached to the tool, it is possible to bend a wire, rod or bar to a scroll form.

It will be appreciated that the sections 79, 80 and 81 may be detachably connected together to permit one or more of said sections to be interchanged with sections of different peripheral surfaces, whereupon windings of different configurations can be obtained.

Figs. 8 and 9 show a support arrangement for the base plate 11, said arrangement comprising a base member 86 with its ends 87 and 88 deflected through 90° to receive the part 11b therebetween. A bore 80 passes through both ends 87 and 88 and a pivot pin 90 passes through the bore 89 and through the bores 14a and 15a of part 11b, thus to pivotally retain base plate 11 with the support 86, 87, 88. The base member also has two bars 91 and 92 welded thereto and bent to channel form and screw elements 93 and 94 pass through the free end limbs 91a and 92a of bars 91 and 92 and whereby the support arrangement can be mounted on the edge of the work bench by entering the edge of the work bench into the channel form of bars 91 and 92 and tensioning the screw elements 93 and 94 to frictionally engage the bench edge.

The end 87 has a bore 95 therethrough so that, when the base plate 11 is displaced to the position shown in Fig. 8, a pin or bolt (not shown) located in bore 95 will retain the base plate 11 in the illustrated position.

A screw 96 passes through a clearance bore 97 in bridge piece 58 and into threaded engagement with the slide element 59 to allow the stroke of slide element 59 to be adjusted.

In the embodiment illustrated in Figs. 10 to 13 inclusive a base plate 111, with a base flange 111a, which may include means (not shown) for attaching the base plate to a frame in identical manner

to the Fig. 1 to 9 embodiment, includes a bore 112 and a drive member 113 presents a spindle 114, rotatably engaged in the bore 112, whereupon the drive member 113 is angularly displaceable about the axis of spindle 114 in a plane parallel to the base plate 111.

5       The drive member 113 is angularly displaced about the axis of spindle 114 by a manually actuated mechanism comprising a spindle 115, rotatable in a bore 116 presented by a base 111; an eccentric 117 secured with the spindle 115, and a hand lever 118 secured to the eccentric 117, the eccentric 117 being located in a cam  
10       aperture 119 in the driving member 113. Thus, when the hand lever 118 is manually displaced to rotate the eccentric 117 about the axis of spindle 115 the eccentric 117, engaged in the cam aperture 119 in the drive member 113, causes the drive member 113 to be angularly displaced about the axis of spindle 114.

15       A yoke 120, pivotally attached to the drive member 113, presents a punch 121 axially displaceable in an aperture 122 of an anvil plate 123 secured to base plate 111. The anvil plate 123 presents a material receiving slot 124 open at one end and which extends from said open end past the aperture 122 and that face 125 of slot 124  
20       remote from the drive member 113 constitutes the anvil surface of plate 123.

When the drive member 113 is displaced to its extreme anti-clockwise position (as viewed in Fig. 10) the punch 121 lies withdrawn from the slot 124 and a sheet of material to be punched, for  
25       example a sheet of metal or plastics material, can be entered into the said slot 124. With the material correctly located relative to the anvil plate 123 the drive member 113 can be rotated clockwise (as viewed in Fig. 1) about the axis of spindle 114, whereupon the punch 121 is advanced, first to trap the material against the anvil surface  
30       125 and, thereafter, upon further clockwise rotation of drive member 113, the punch 121, co-operating with the aperture 122 in anvil surface 125, shears a slug from the material and pushes the slug into the aperture 122 behind surface 125. The drive member 113 is then rotated anticlockwise about the axis of spindle 114 to withdraw the  
35       punch 121, thereby allowing the material to be removed from the tool.

It will be observed from Fig. 12 that the punch is of rectangular

- 11 -

cross-section, the base of slot 124 is inclined on both sides of the mid-plane of anvil plate 123, and the surface of the punch 122 closest to the bore of slot 124 is immediately adjacent said base whereupon, a sheet material having an edge in slot 124 can have a rectangular piece notched out of said edge at right angles to said edge or, by inclining the edge to the plane of the plate 123, inclined to said edge.

The base plate 111 includes an arcuate slot 126, the arcuate sides of which are based on radii the centres of which lie on the rotational axis of the spindle 114, and the drive member 113 includes, at its lower edge, an arcuate notch 127 the centre of which is at the same radius as the mean radius of the slot 126. Thus, with the drive member 113 rotated to its most clockwise position (as viewed in Fig. 10) a round rod, bar or wire can be slidably inserted through the slot 126 and, by rotating the drive member 113 anticlockwise about the axis of spindle 114, the inserted member will be sheared.

A tool plate 128 is secured to that face of base plate 111 remote from the drive member 113 and said plate 128 presents an arcuate slot 129 therein, the slot 129 being concentric with the slot 126 but of larger overall dimensions so that a block 130, slidably disposed in slot 129, is held captive against that part of base plate 111 exposed through slot 129 (as shown in Fig. 13). The block 129 is secured to drive member 113 by a pin 131 which has part of its length threaded, the threaded end of the pin 131 passing first through a threaded bore in block 129, through the slot 126, and into a threaded bore 132 in the drive member 113.

As will be seen from Fig. 11 and 13 the unthreaded part of pin 131 projects from the block 130 and the base plate 111 presents two fixed pins 133 and 134, one to each side of the arcuate slot 129, and the axes of pins 133 and 134 lie in a common plane passing through the axis of spindle 114. Thus, a bar or rod of material can be placed between the pins 131, 133 and 134, pins 133 and 134 being to one side of the rod or bar and the pin 131 being on the other side of the bar whereupon, by rotation of drive member 113 in the appropriate direction, the pin 131 is displaced about the axis of spindle 114 and can engage the bar material and, in co-operation with the posts 133

- 12 -

and 134, bend the bar material. As with the embodiment of Figs. 1 to 9 inclusive, the pins 131, 133 and 134 may have roller bodies rotatably supported thereon and the pin 131 may have its roller body knurled and rotatable by way of a manual lever (such as the lever 76) to continue a bend in the bar material in the length direction of said material.

The tool plate 128 supports a tool block 135 in an opening 136 through base plate 111 and two adjacent edges of block 135 co-operate with two adjacent edges of an opening 137 in drive member 113 to define a shearing device for angle sections.

A tool block 138 is inserted in a slot opening 139 in base plate 111 and is secured in said slot opening 139, as by welding, and the upper edge of block 138 co-operates with an edge region 140 of drive member 113 to define a shearing device for flat bar and strip materials.

It will be seen that with the above described arrangement bar or strip material can be sheared, (block 138 and edge 140) notched (punch 121 and anvil plate 123) bent (pins 131, 133 and 134), or rolled (pins 131, 133 and 134) when fitted with rollers and a roller actuating hand lever), sheet material can be punched or notched (pin 121 and anvil plate 123), rod or wire can be sheared (slot 26 and notch 127) and bent or rolled (pins 131, 133 and 134) and angle section material can be sheared (tool plate 135 and the edges of opening 137) or notched (pin 121 and anvil plate 123) simply by displacing the drive member 113 in the appropriate direction of angular displacement.

30

35

CLAIMS

1. A manually actuable combination tool comprising a base plate (11, 111) and a two-part metal working device, one part of which is presented by the base plate (11, 111) and the other part is dis-  
placeable relative to the base plate (11,111) via a hand lever (42,  
5 118), characterised in that a drive member (17, 113) is pivotally  
attached to the base plate (11, 111), a plurality of two-part metal  
working devices each have one part (22, 28, 50, 62, 69, 72, or 123,  
126, 128, 131, 133, 135 or 138) presented by the base plate (11, 111)  
and the other part (33, 59, 64, 66, 75 or 121, 127, 128, 130, 131, 137  
10 or 140) presented by the said drive member (17, 113) and the drive  
member (17, 113) is rotatable relative to the base plate (11, 111) by  
a single hand lever (42, 118) to effect simultaneous displacement of  
all the parts (33, 59, 64, 66, 75 or 121, 127, 128, 130, 131, 137 or  
140) of said metal working devices presented by the drive member (17,  
15 113) relative to their co-operating parts (22, 28, 50, 62, 69, 72 or  
123, 126, 128, 131, 133, 135 or 138) presented by the base plate (11,  
(111).
2. A manually actuable combination tool as claimed in claim 1 charac-  
terised in that the hand lever (42, 118) is pivotally attached to said  
20 base plate (11, 111) and includes a cam (44, 117) presenting an edge  
cam profile, eccentric to the rotational axis for the hand lever (42,  
118), engaged with the drive member (17, 113) the axis of said cam (44,  
117) being spaced from the pivotal axis of the drive member (17, 113).
3. A manually actuable combination tool as claimed in claim 1 or 2  
25 characterised in that the base plate (11, 111) is supported by a frame  
(86, to 92) so as to be pivotally displaceable between two positions  
substantially at right angles to one another.
4. A manually actuable combination tool as claimed in claim 1, 2 or 3  
characterised in that the base plate (11, 111) presents guides (50 or  
30 128) for a slide element (59, 130) and said slide element (59, 130) is  
linked to said drive member (17, 113) for reciprocation in response to  
oscillation of said drive member (17, 113) and said slide element (59,  
130) presents one part (64, 66, 75) of a metal working device whilst  
the base plate (11, 111) presents the other part (62, 69 and 72; 127,  
35 133, 134) of the device.
5. A manually actuable combination tool as claimed in any preceding

claim in which one (62, 66) or both parts of selected metal working devices are replaceable by a part (66, 67) or parts of other metal working devices whereby to increase the metal working operations performable by the tool.

- 5 6. A manually actuatable combination tool as claimed in any preceding claim characterised in that the base plate (11, 111) and/or the drive member (17, 113) is adapted to have at least one metal working device (75, 76 or 78 to 81) attached thereto co-operable with other working devices (69, 72 or 84) of the tool to increase the range of metal working operations performable by the tool.
- 10 7. A manually actuatable combination tool as claimed in any preceding claim characterised in that the tool includes devices for shearing (22 or 126 and 127, 135 and 137, 138 and 140), notching (28 and 33, 121 and 123), punching (28 and 33, 121 and 123), apertures and bending (66 and 69, 72, 75 and 69, 72, 131 and 133, 134) metal in strip, bar or rod form.
- 15 8. A manually actuatable combination tool as claimed in claim 4 or claim 6 when dependent upon claim 4 characterised in that the slide member (59) includes a peg (84) and a pivot pin is fixed relative to the base plate (11, 111) to support a manually rotatable lever (78) which presents an arcuate member (79) rigid with said lever (78) and having a peripheral curvature increasing in radius from a slot-like opening (82) intended to receive one end of a metal strip, rod or wire therein.
- 20 9. A manually actuatable combination tool as claimed in claim 8 characterised in that a second arcuate member (80) is pivotally attached at one end to that end of said first arcuate member (79) defining the periphery of greatest radius and, in that position for said second segment (80) closest to the pivotal axis for the manually rotatable lever (78), said second segment (80) presents a periphery which increases in radius from the pivotal connection with the first segment (79) in such manner that said first and second segments (79, 80), in combination, present a periphery gradually increasing in radius away from said slot-like opening (87) and in which a third arcuate member (81) is pivotally attached at one end to that end of the second member (80) most remote from the first member (79) and, when in its
- 25
- 30
- 35

- 15 -

closest position to the axis of the manually rotatable lever (78), the third arcuate member (81) presents a periphery which increases in radius from that end attached to the second segment (80) in a manner such that the three arcuate members (79, 80, 81), in combination, present a substantially continuous periphery which increases in radius towards the free end of the third segment (81).

5

10. A manually actuatable combination tool as claimed in claim 9 characterised in that said arcuate members (79, 80, 81) are detachably secured together and are interchangeable with other arcuate members of different curvatures.

10

11. A manually actuatable combination tool as claimed in any preceding claim in which a tool block (135) secured to the base plate (11, 111) co-operates with an opening (137) through the drive member (17, 113) to define two inclined shearing edges for shearing angle section material.

15

20

25

30

35

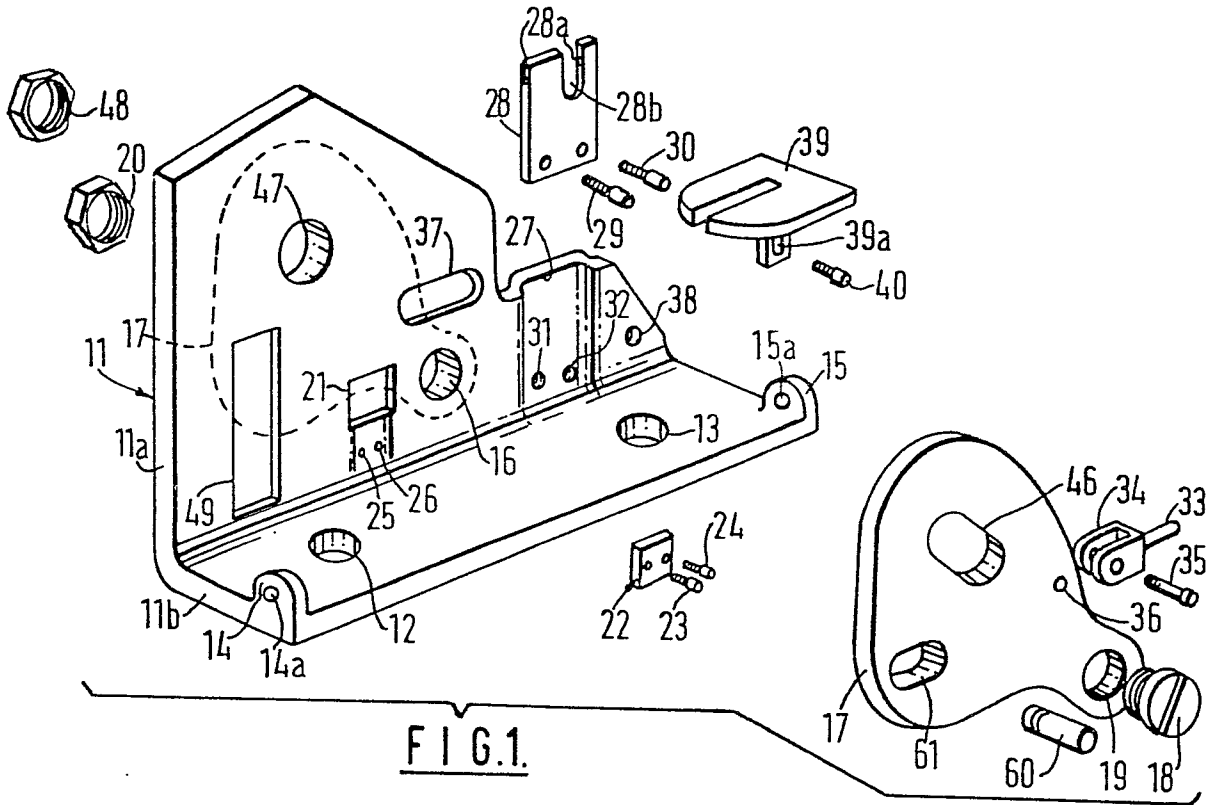

FIG. 1.

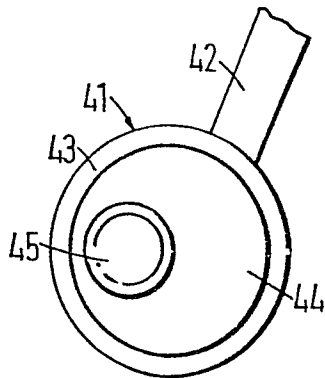

FIG. 2.

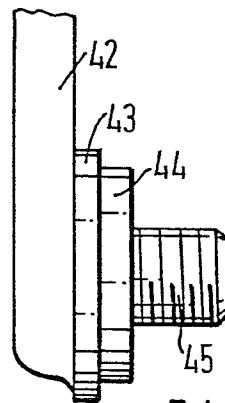

FIG. 3.

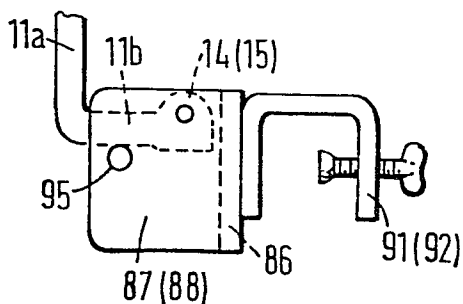

FIG. 8.

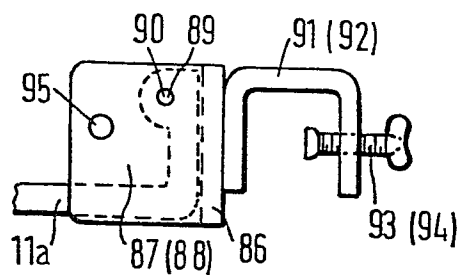

FIG. 9.

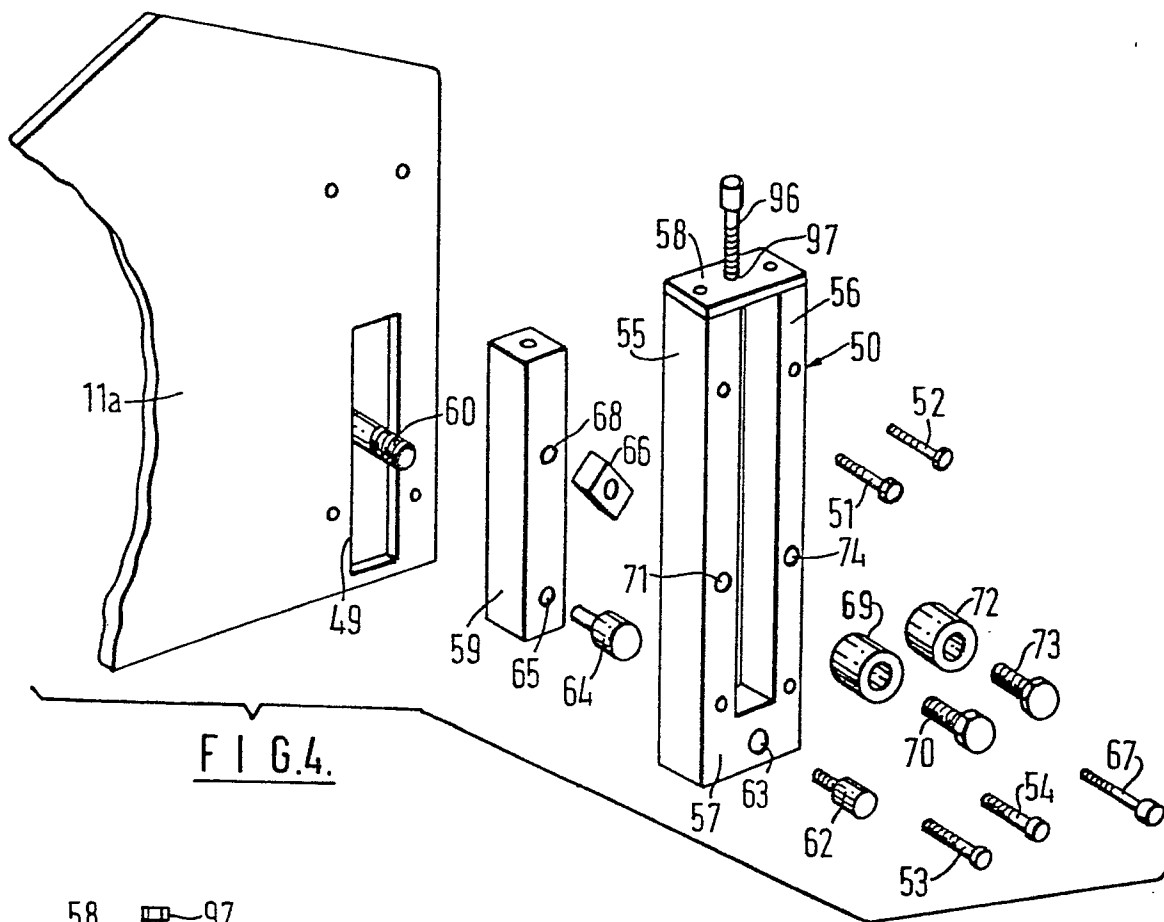

FIG. 4.

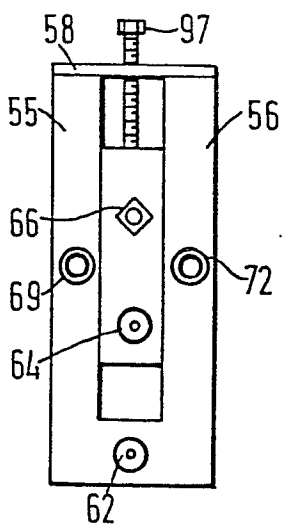

FIG. 5.

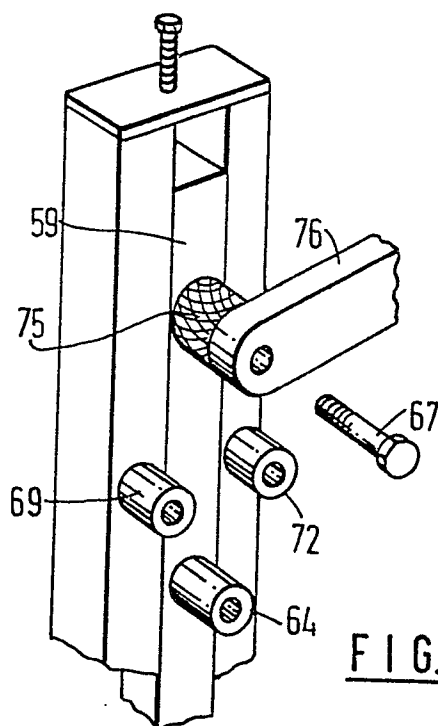

FIG. 6.

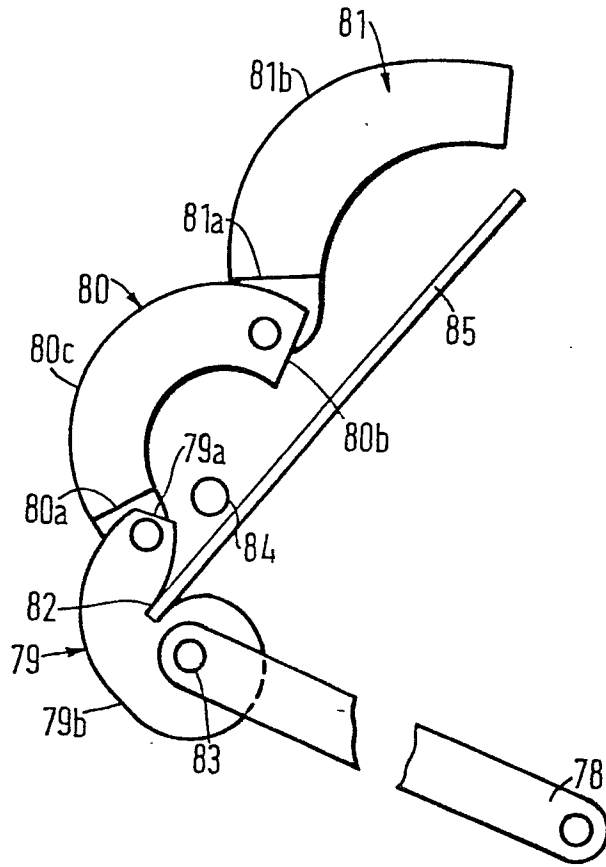
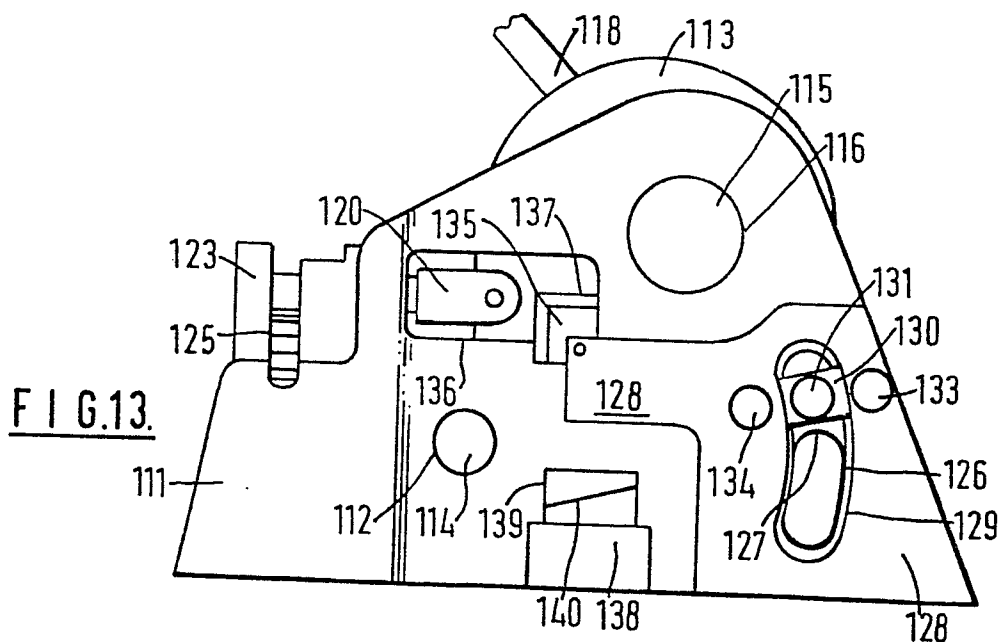
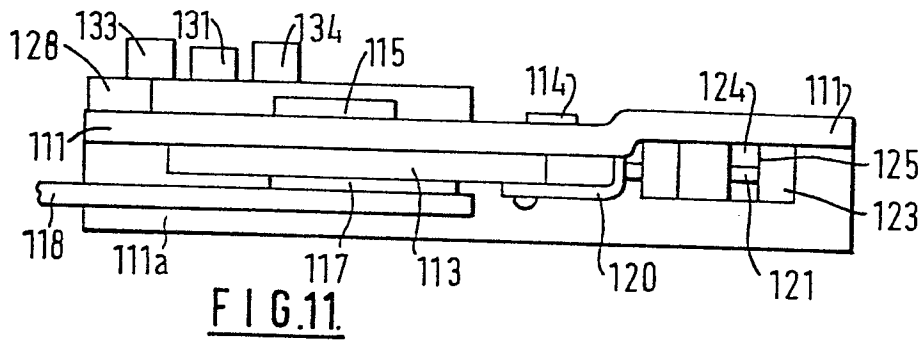
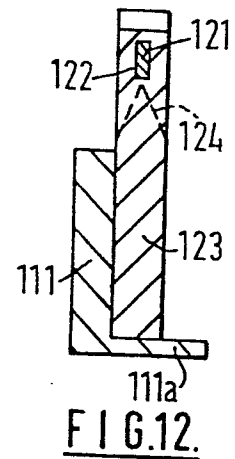
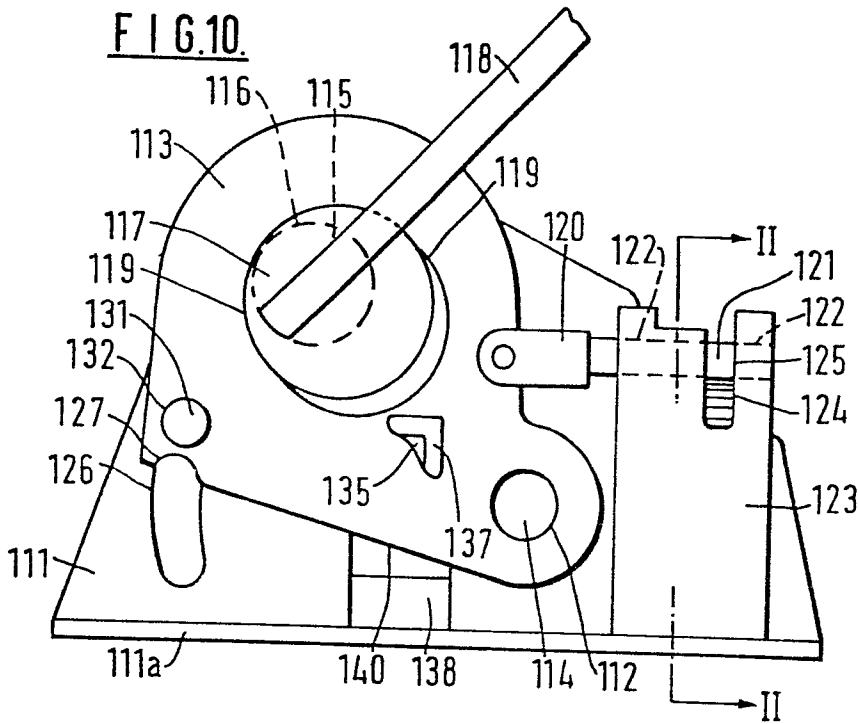

FIG. 7.





European Patent  
Office

EUROPEAN SEARCH REPORT

0033245

Application number

EP 81 30 0332.4

DOCUMENTS CONSIDERED TO BE RELEVANT			CLASSIFICATION OF THE APPLICATION (Int. Cl. <sup>3</sup> )
Category	Citation of document with indication, where appropriate, of relevant passages	Relevant to claim	
X	<u>FR - A1 - 2 361 982</u> (R. BORNAND) * pages 1 to 3; fig. 1 to 3 * & <u>US - A - 4 132 102</u> ---	1	B 26 D 9/00
A	<u>US - A - 1 736 559</u> (E. VOLLRATH) ----		
			TECHNICAL FIELDS SEARCHED (Int. Cl. <sup>3</sup> )
			B 25 F 1/00 B 26 D 9/00 B 26 D 11/00 B 26 F 1/00
			CATEGORY OF CITED DOCUMENTS
			X: particularly relevant A: technological background O: non-written disclosure P: intermediate document T: theory or principle underlying the invention E: conflicting application D: document cited in the application L: citation for other reasons
			&: member of the same patent family, corresponding document
<input checked="" type="checkbox"/> The present search report has been drawn up for all claims			
Place of search	Date of completion of the search	Examiner	
Berlin	21-04-1981	HOFFMANN	