



US 20070188467A1

(19) **United States**

(12) **Patent Application Publication**

LEE et al.

(10) **Pub. No.: US 2007/0188467 A1**

(43) **Pub. Date: Aug. 16, 2007**

(54) **POWER SAVING SYSTEM FOR A HANDHELD COMMUNICATION DEVICE**

(22) Filed: **Jun. 13, 2006**

Related U.S. Application Data

(75) Inventors: **Matthew LEE**, Belleville (CA); **Andrew BOCKING**, Waterloo (CA); **David MAK-FAN**, Waterloo (CA); **Steven FYKE**, Waterloo (CA)

(60) Provisional application No. 60/773,145, filed on Feb. 13, 2006, provisional application No. 60/773,799, filed on Feb. 14, 2006.

Publication Classification

Correspondence Address:
NOVAK DRUCE & QUIGG, LLP
(RIM PROSECUTION)
1000 LOUISIANA STREET, 53RD FLOOR
HOUSTON, TX 77002

(51) **Int. Cl.**
G09G 5/08 (2006.01)
G06F 3/033 (2006.01)

(52) **U.S. Cl.** **345/167**

(57) **ABSTRACT**

Method and arrangement that provides a power-saving mode for a handheld electronic device. The power-saving mode is enabled through disabling a sensor that detects motion of a ball of the trackball navigation tool and disabling the display screen of the handheld electronic device. The power-saving mode may be exited before disablement of the sensor when the display screen is disabled first.

(73) Assignee: **RESEARCH IN MOTION LIMITED**, Waterloo (CA)

(21) Appl. No.: **11/423,779**

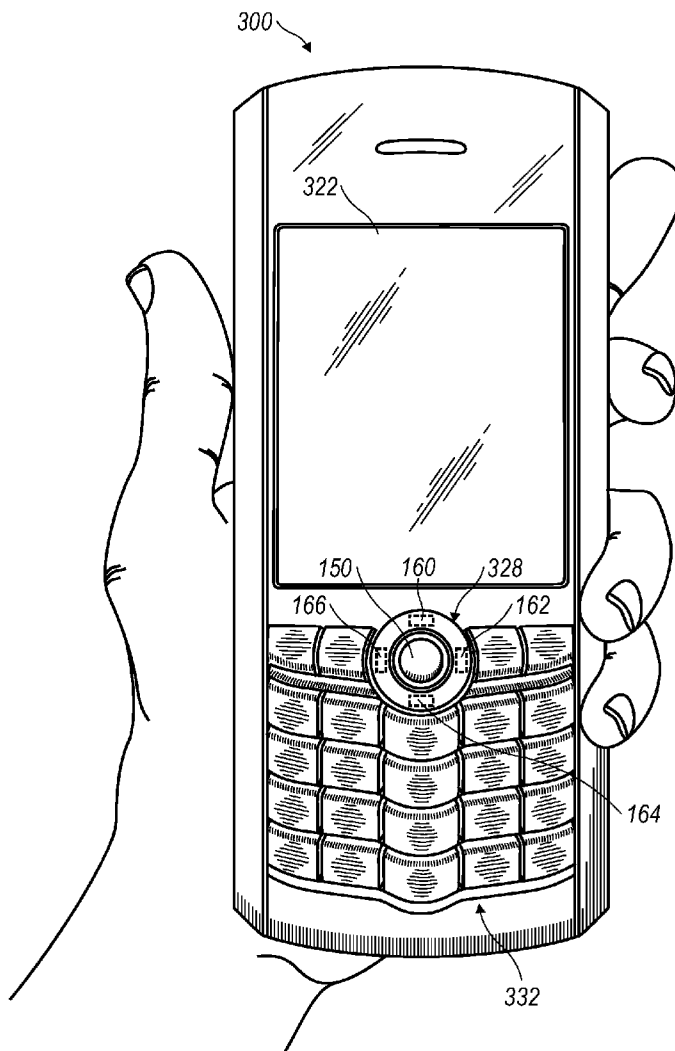

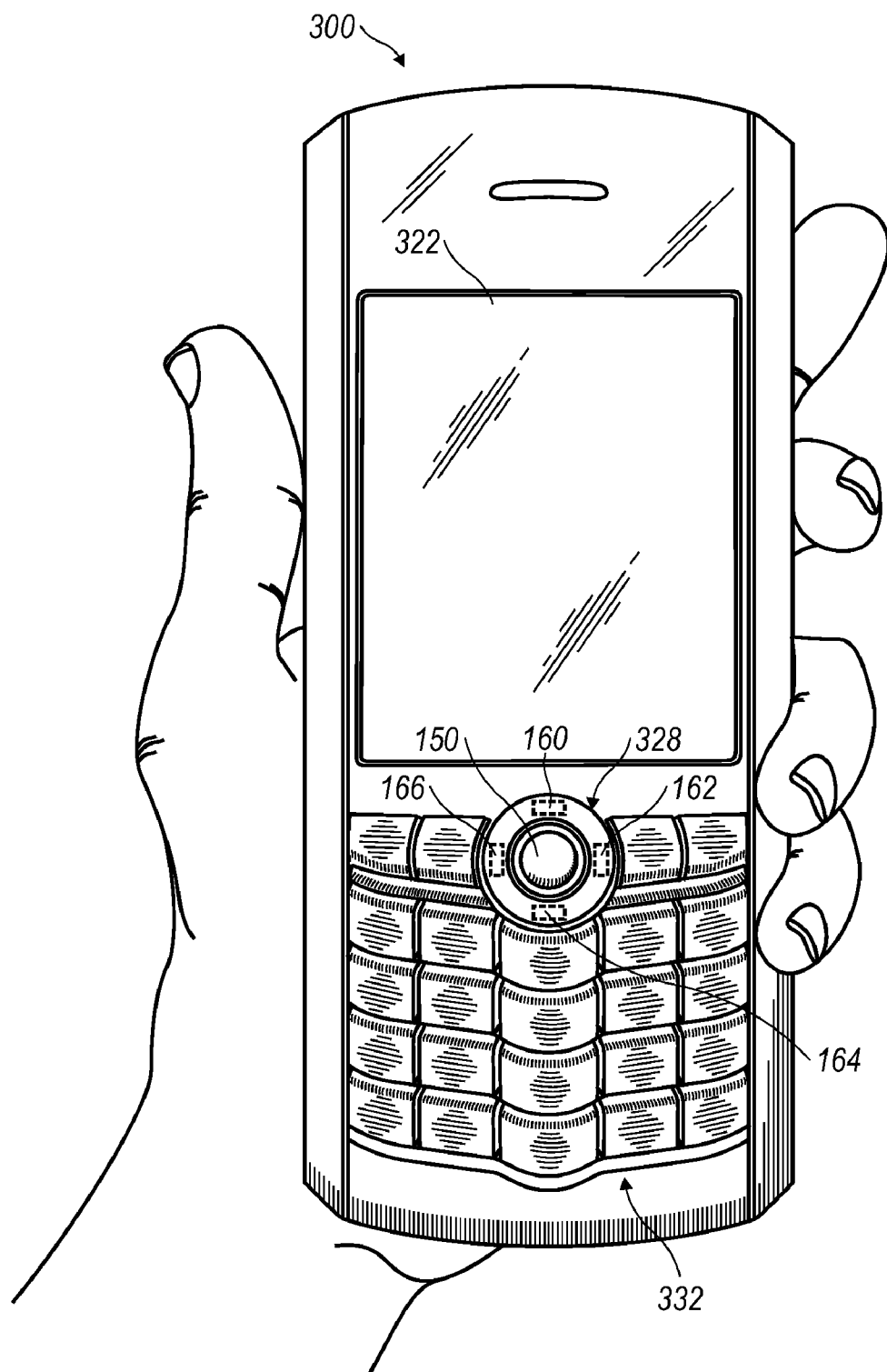

FIG. 1

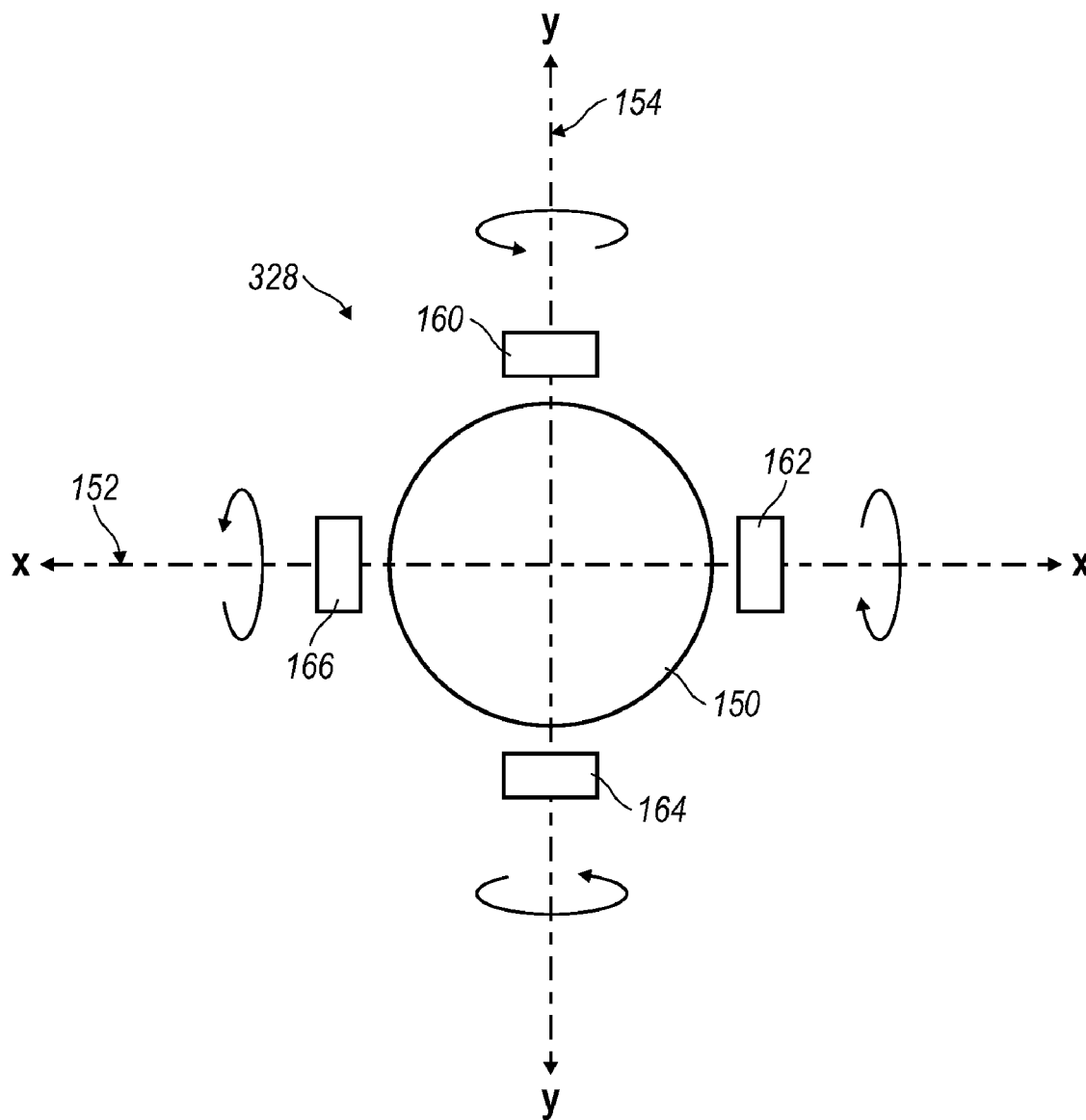

FIG. 2

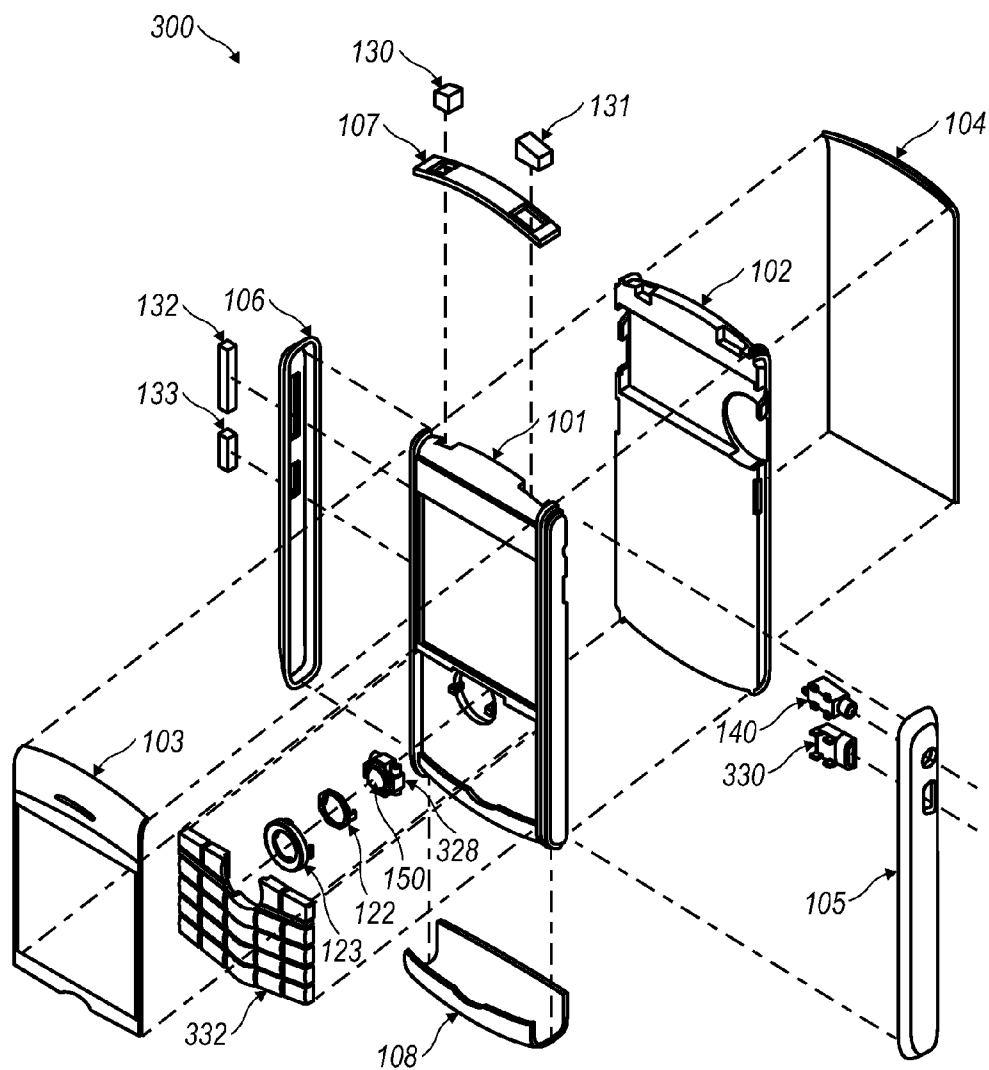

FIG. 3

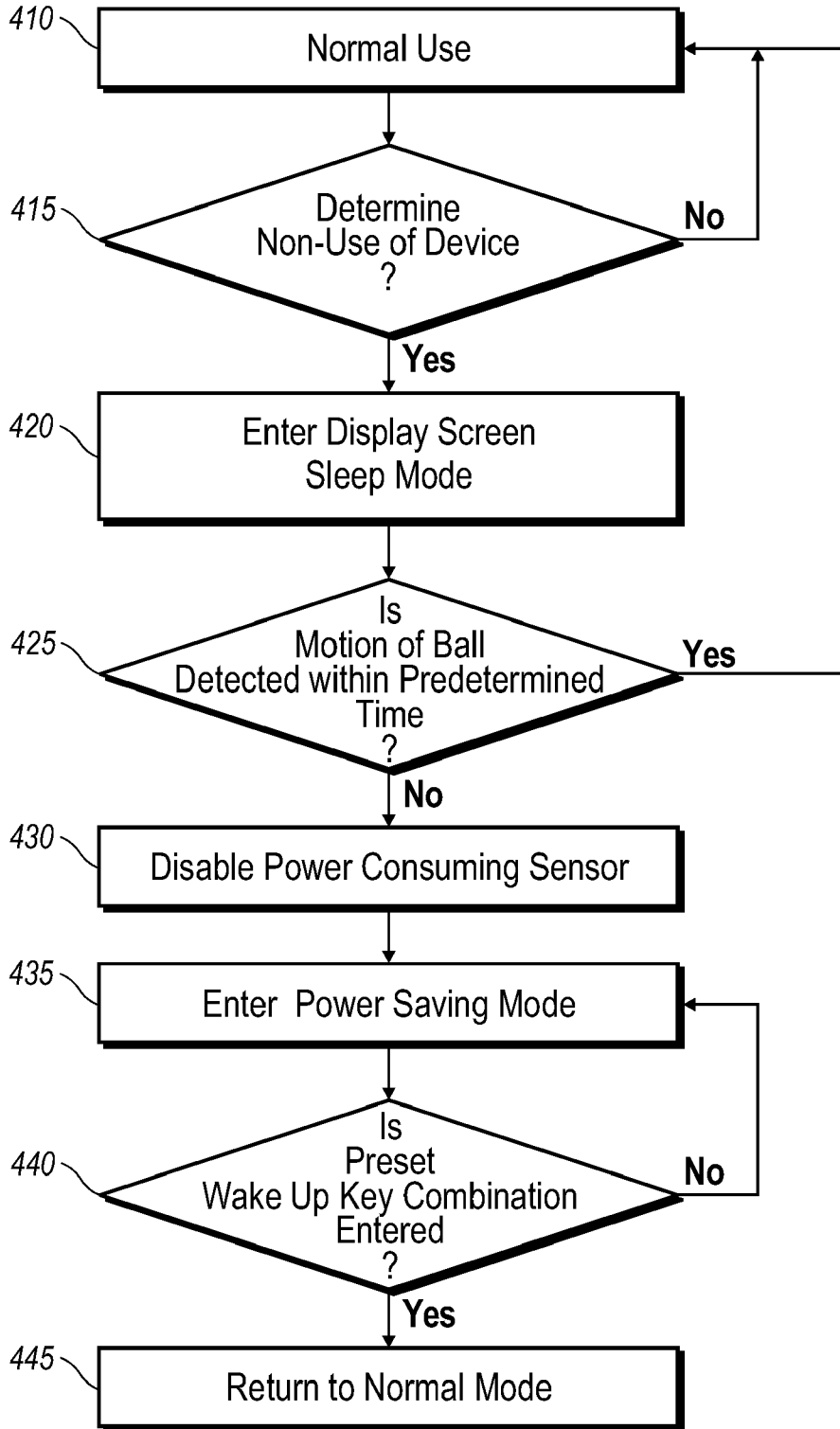

FIG. 4

1	2	3	4	5	6	7	8	9	0
Q	W	E	R	T	Y	U	I	O	P
A	S	D	F	G	H	J	K	L	
Z	X	C	V	B	N	M			

44

FIG. 5

1	2	3	4	5	6	7	8	9	0
Q	W	E	R	T	Z	U	I	O	P
A	S	D	F	G	H	J	K	L	
Y	X	C	V	B	N	M			

44

FIG. 6

1	2	3	4	5	6	7	8	9	0
A	Z	E	R	T	Y	U	I	O	P
Q	S	D	F	G	H	J	K	L	
W	X	C	V	B	N	M			

44

FIG. 7

1	2	3	4	5	6	7	8	9	0
			P	Y	F	G	C	R	L
A	O	E	U	I	D	H	Y	N	S
	Q	J	K	X	B	M	W	V	Z

FIG. 8

1	2	3	4	5	6	7	8	9	0
Q	W	E	R	T	Y	U	I	O	P
A	S	D	F	G	H	J	K	L	
Z	X	C	V	B	N	M			

7	8	9
4	5	6
1	2	3
0		

FIG. 9

1	2	3
4	5	6
7	8	9
*	0	#

FIG. 10

1	2	3
4	5	6
7	8	9
*	0	#
shift	0	space

FIG. 11

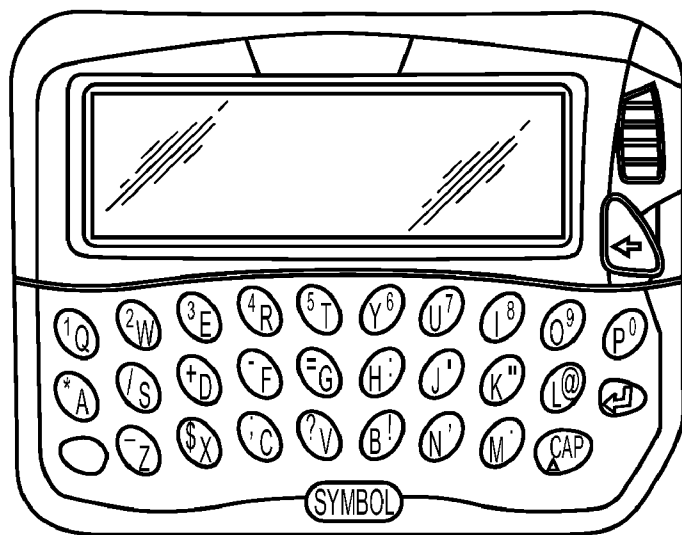

FIG. 12

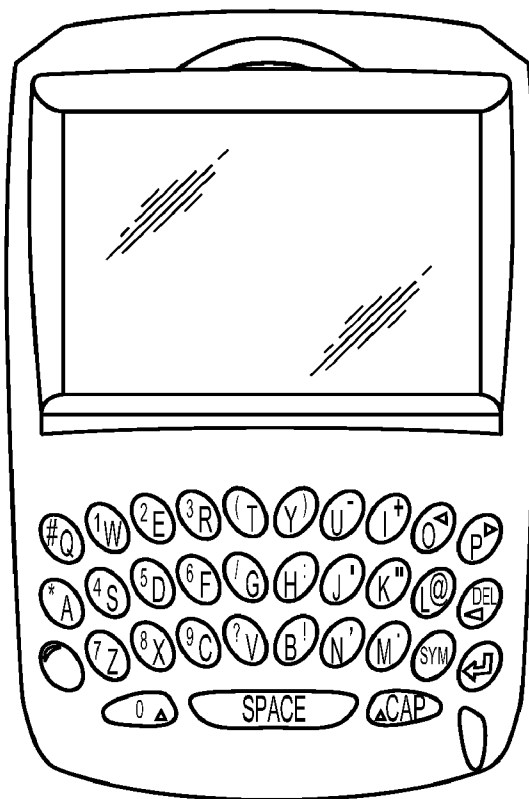

FIG. 13

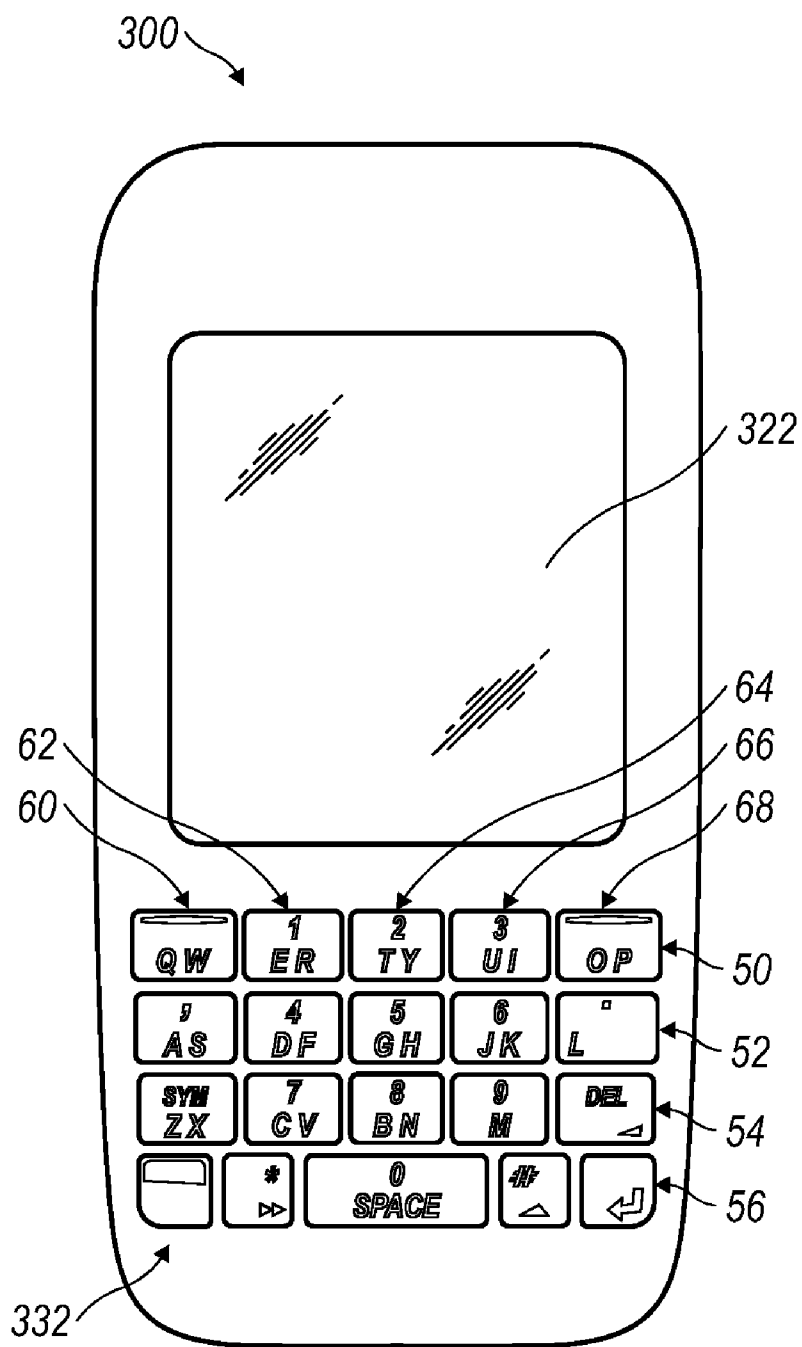

FIG. 14

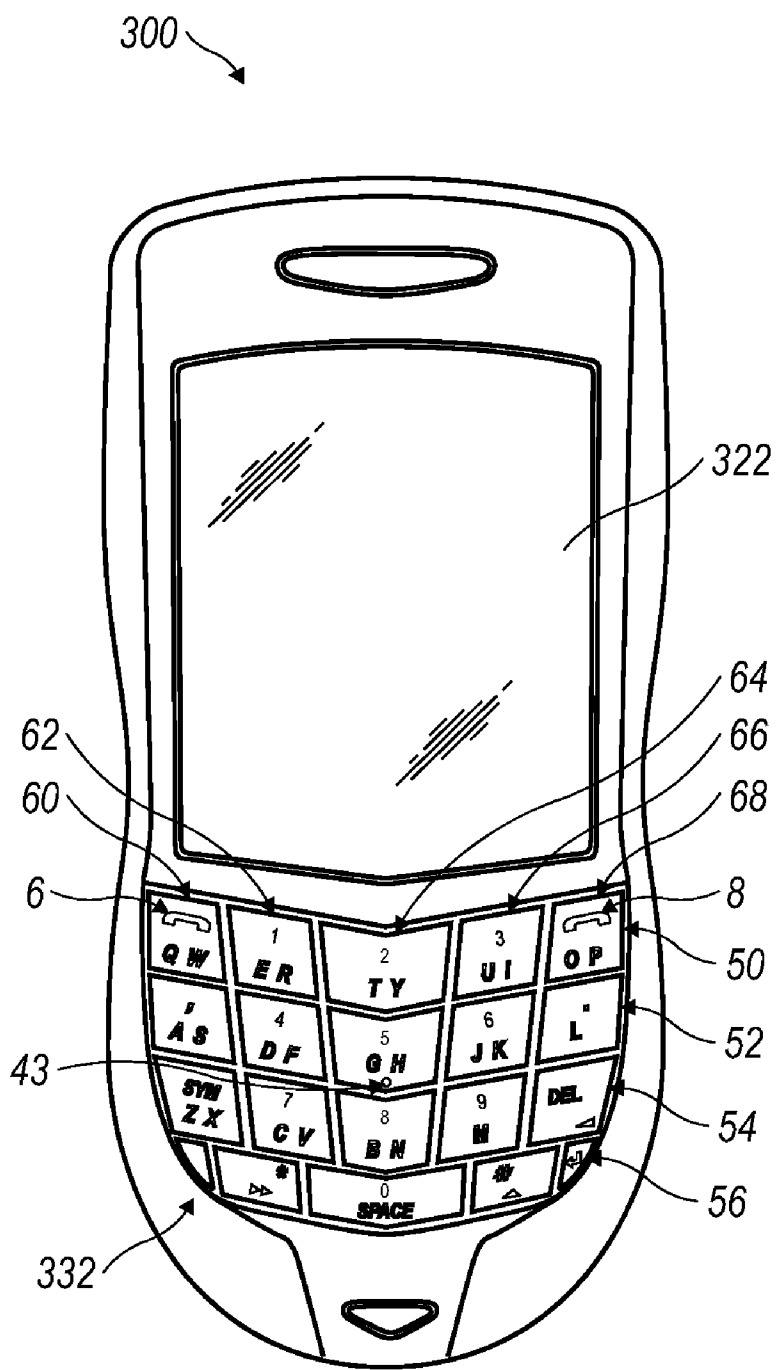

FIG. 15

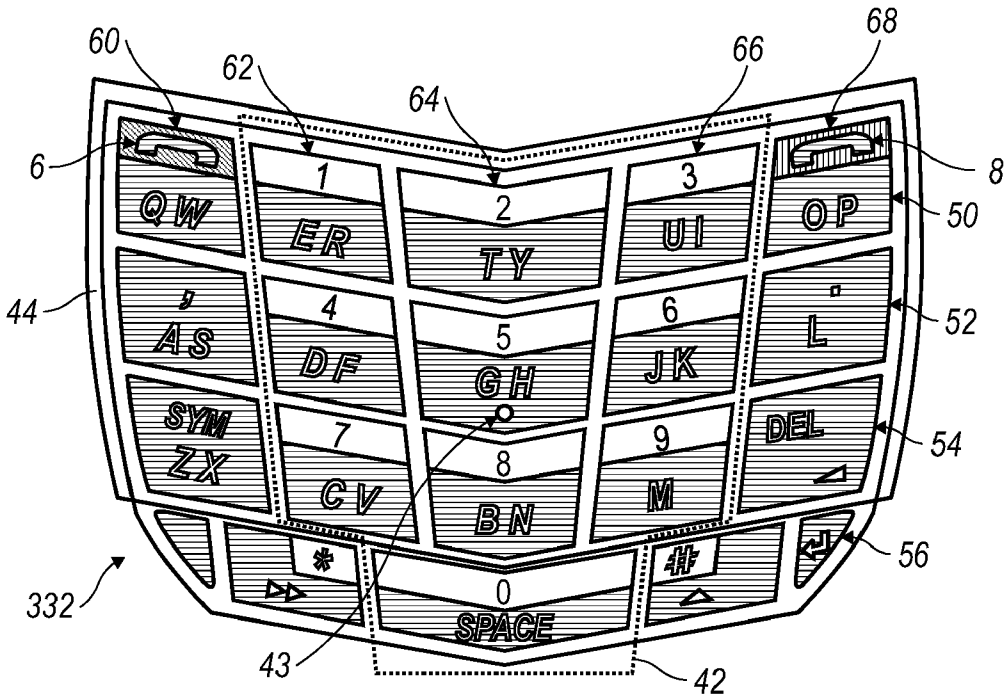

FIG. 16

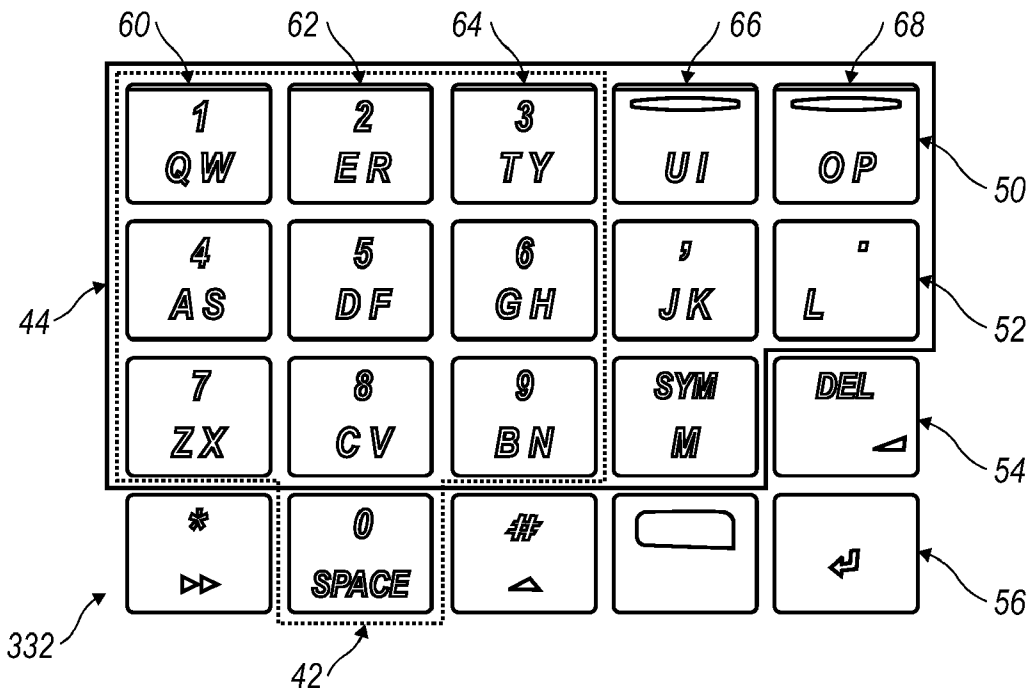

FIG. 17

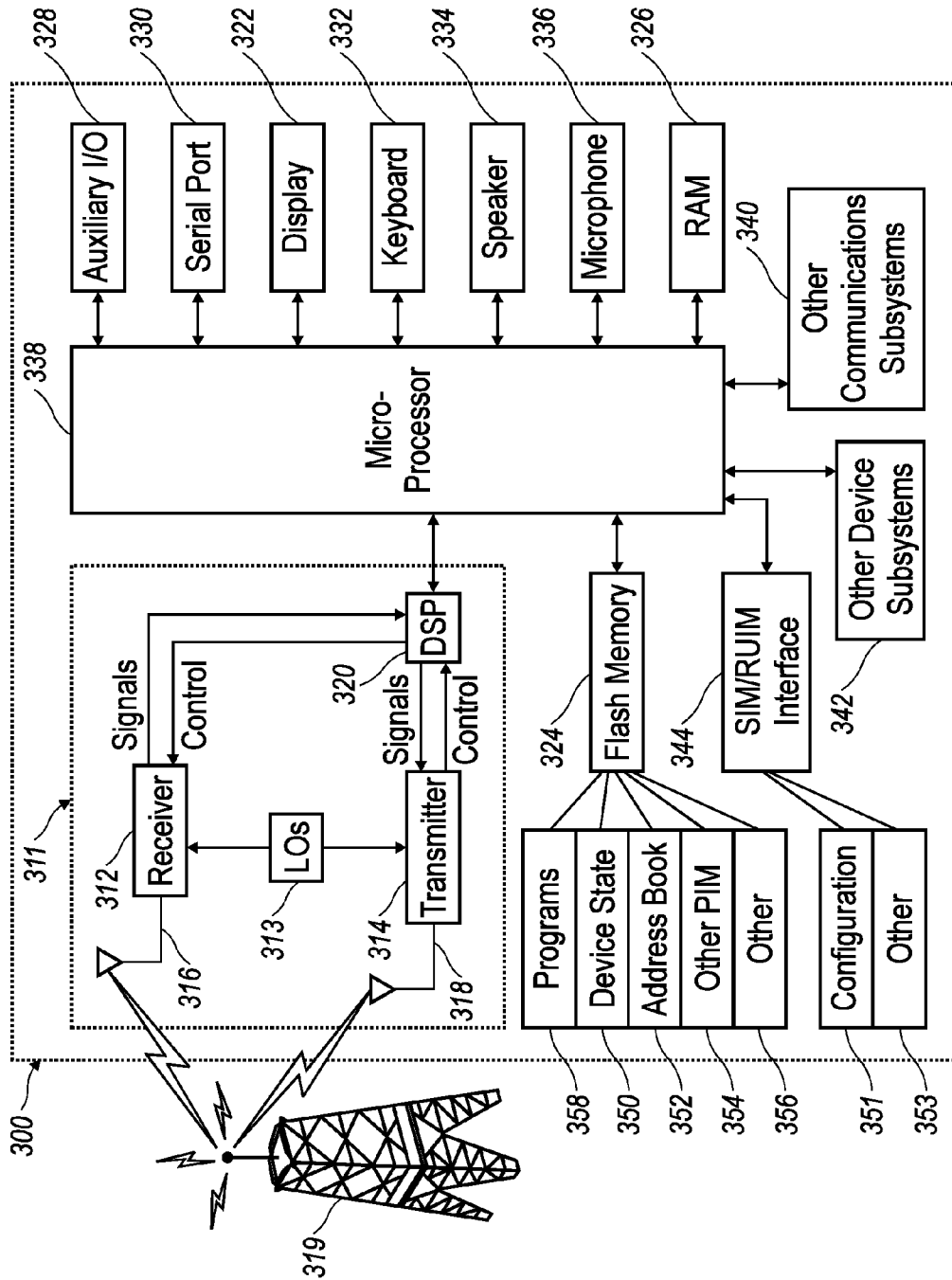

FIG. 18

POWER SAVING SYSTEM FOR A HANDHELD COMMUNICATION DEVICE

CROSS-REFERENCE TO RELATED APPLICATIONS

[0001] The present application claims the benefit of U.S. Provisional Application Nos. 60/773,145 and 60/773,799 filed Feb. 13, 2006 and Feb. 14, 2006, respectively. Said applications are expressly incorporated herein by reference in their entirety.

FIELD

[0002] This disclosure relates to a handheld electronic device with a trackball, and more particularly, to saving power when directional navigational sensors and a bright display are not required.

BACKGROUND

[0003] Handheld electronic devices continue to become more prevalent and advanced. One of the features that continues to evolve is the navigation system of the handheld electronic device. Several navigation tools have been used including trackwheels, 4-way navigational pads, and joysticks. In the present description, a trackball is disclosed as a navigational tool.

[0004] The use of a trackball presents challenges and advantages not before experienced in the design of navigational tools. Current technology for trackballs utilizes pairs of sensors located about the trackball for sensing rotational motion of the trackball which is representative of the desired direction the user would like the cursor to move on the screen. The trackball is also equipped with a sensor for detecting that a selection is being made by the user depressing the trackball.

[0005] Furthermore, handheld electronic devices are evolving into smaller entities. With each new generation, these devices possess greater functional capabilities and are more responsive to the daily needs of their users. As reliance upon these devices grows, the user demands immediate access to them. Consequently, users are inclined to carry them in their pockets.

[0006] Since the trackball is exposed and rotates freely, it is susceptible to unintentional and usually undesirable rotation. As an example, this can occur when the user places the handheld electronic device in his or her pocket and the rubbing of the fabric against the trackball causes unintentional rolling of the trackball. The undesirable nature of this occurrence is at least partly attributable to the fact that actuation of a device's navigation tool traditionally restores power to the screen (after having entered a sleep mode) because it is usually interpreted as an indication that the user wants to use the device in some capacity. Therefore, if the trackball is frequently unintentionally actuated, the screen will be lit unnecessarily, wasting battery power.

[0007] As described above, in the instance of a trackball being used as the navigation tool, sensors are required to detect motion of the trackball. Therefore, in order to be able to detect rollerball motion indicative of desired use, the sensors must always be powered-on which consumes energy and reduces the energy savings experienced because the screen has been put into sleep mode.

[0008] In response to these needs and deficiencies, the presently presented solutions have been developed in order

to avoid the unnecessary consumption of power in handheld devices that utilize trackball navigation tools.

BRIEF DESCRIPTION OF THE DRAWINGS

[0009] Exemplary methods and arrangements conducted and configured according to the advantageous solutions presented herein are depicted in the accompanying drawings wherein:

[0010] FIG. 1 is a perspective view of a handheld communication device cradled in a user's hand;

[0011] FIG. 2 is a schematic representation of an auxiliary input in the form of a trackball;

[0012] FIG. 3 is an exploded perspective view of an exemplary wireless handheld electronic device incorporating a trackball assembly as at the auxiliary input;

[0013] FIG. 4 is a flow chart illustrating a method according to the invention;

[0014] FIG. 5 illustrates an exemplary QWERTY keyboard layout;

[0015] FIG. 6 illustrates an exemplary QWERTZ keyboard layout;

[0016] FIG. 7 illustrates an exemplary AZERTY keyboard layout;

[0017] FIG. 8 illustrates an exemplary Dvorak keyboard layout;

[0018] FIG. 9 illustrates a QWERTY keyboard layout paired with a traditional ten-key keyboard;

[0019] FIG. 10 illustrates ten digits comprising the numerals 0-9 arranged as on a telephone keypad, including the * and # astride the zero;

[0020] FIG. 11 illustrates a numeric phone key arrangement according to the ITU Standard E.161 including both numerals and letters;

[0021] FIG. 12 is a front view of an exemplary handheld electronic device including a full QWERTY keyboard;

[0022] FIG. 13 is a front view of another exemplary handheld electronic device including a full QWERTY keyboard;

[0023] FIG. 14 is a front view of an exemplary handheld electronic device including a reduced QWERTY keyboard;

[0024] FIG. 15 is an elevational view of the front face of another exemplary handheld electronic device including a reduced QWERTY keyboard;

[0025] FIG. 16 is a detail view of the reduced QWERTY keyboard of device of FIG. 15;

[0026] FIG. 17 is a detail view of an alternative reduced QWERTY keyboard; and

[0027] FIG. 18 is a block diagram representing a wireless handheld communication device interacting in a communication network.

DETAILED DESCRIPTION

[0028] As intimated hereinabove, one of the more important aspects of the handheld electronic device to which this disclosure is directed is its size. While some users will grasp the device in both hands, it is intended that a predominance of users will cradle the device in one hand in such a manner that input and control over the device can be affected using the thumb of the same hand in which the device is held. Therefore the size of the device must be kept relatively small; of its dimensions, limiting the width of the device is most important with respect to assuring cradleability in a user's hand. Moreover, it is preferred that the width of the

device be maintained at less than ten centimeters (approximately four inches). Keeping the device within these dimensional limits provides a hand cradleable unit that users prefer for its useability and portability. Limitations with respect to the height (length) of the device are less stringent with importance placed on maintaining device hand-cradleability. Therefore, in order to gain greater size, the device can be advantageously configured so that its height is greater than its width, but still remain easily supported and operated in one hand.

[0029] A potential problem is presented by the small size of the device in that there is limited exterior surface area for the inclusion of user input and device output features. This is especially true for the “prime real estate” of the front face of the device where it is most advantageous to include a display screen that outputs information to the user and which is preferably above a keyboard utilized for data entry into the device by the user. If the screen is provided below the keyboard, a problem occurs in being able to see the screen while inputting data. Therefore it is preferred that the display screen be above the input area, thereby solving the problem by assuring that the hands and fingers do not block the view of the screen during data entry periods.

[0030] To facilitate textual data entry, an alphabetic keyboard is provided. In one version, a full alphabetic keyboard is utilized in which there is one key per letter. This is preferred by some users because it can be arranged to resemble a standard keyboard with which they are most familiar. In this regard, the associated letters can be advantageously organized in QWERTY, QWERTZ or AZERTY layouts, among others, thereby capitalizing on certain users’ familiarity with these special letter orders. In order to stay within the bounds of a limited front surface area, however, each of the keys must be commensurately small when, for example, twenty-six keys must be provided in the instance of the English language. An alternative configuration is to provide a reduced keyboard in which at least some of the keys have more than one letter associated therewith. This means that fewer keys can be included which makes it possible for those fewer keys to each be larger than in the instance when a full keyboard is provided on a similarly dimensioned device. Some users will prefer the solution of the larger keys over the smaller ones, but it is necessary that software or hardware solutions be provided in order to discriminate which of the several associated letters the user intends based on a particular key actuation; a problem the full keyboard avoids. Preferably, this character discrimination is accomplished utilizing disambiguation software accommodated within the device. As with the other software programs embodied within the device, a memory and micro-processor are provided within the body of the handheld unit for receiving, storing, processing, and outputting data during use. Therefore, the problem of needing a textual data input means is solved by the provision of either a full or reduced alphabetic keyboard on the presently disclosed handheld electronic device.

[0031] Keys, typically of a push-button or push-pad nature, perform well as data entry devices but present problems to the user when they must also be used to affect navigational control over a screen-cursor. In order to solve this problem the present handheld electronic device preferably includes an auxiliary input that acts as a cursor navigational tool and which is also exteriorly located upon the front face of the device. Its front face location is particularly

advantageous because it makes the tool easily thumb-actuable like the keys of the keyboard. A particularly usable embodiment provides the navigational tool in the form of a trackball which is easily utilized to instruct two-dimensional screen cursor movement in substantially any direction, as well as act as an actuator when the ball of the trackball is depressible like a button. The placement of the trackball is preferably above the keyboard and below the display screen; here, it avoids interference during keyboarding and does not block the user’s view of the display screen during use.

[0032] In some configurations, the handheld electronic device may be standalone in that it is not connectable to the “outside world.” One example would be a PDA that stores such things as calendars and contact information, but is not capable of synchronizing or communicating with other devices. In most situations such isolation will be detrimentally viewed in that at least synchronization is a highly desired characteristic of handheld devices today. Moreover, the utility of the device is significantly enhanced when connectable within a system, and particularly when connectable on a wireless basis in a system in which both voice and text messaging are accommodated.

[0033] This disclosure describes methods and arrangements for reducing power consumption during periods of non-use by a handheld electronic device, variously configured as described above, and particularly one in which a trackball is used to navigate through the various screens of the device. A power-saving mode is enabled through disablement of the sensor(s) that detect motion of a ball of the trackball navigation tool and by also disabling the display screen of the handheld electronic device. The power-saving mode may be exited before disablement of the sensor when the display screen is disabled first.

[0034] In one embodiment, the plurality of sensors numbers two. One of the two sensors outputs signals indicative of x-component rolling motion of the trackball relative to the handheld electronic device and about the intersecting y-axis of the trackball. The other of the two sensors outputs signals indicative of y-component rolling motion of the trackball relative to the handheld electronic device and about the intersecting x-axis of the trackball. In this configuration, the two sensors are oriented circumferentially about the trackball with approximately ninety degree spacing therebetween. Each of the sensors may take the form of a hall effect sensor located proximate the trackball. Other types of sensors can be used as well including optical, capacitive, and mechanical sensors.

[0035] In another embodiment, the plurality of sensors numbers four. A first pair of opposed sensors output signals indicative of x-component rolling motion of the trackball relative to the handheld electronic device and about the intersecting y-axis. A second pair of opposed sensors output signals indicative of a y-component rolling motion of the trackball relative to the handheld electronic device and about the intersecting x-axis. The four sensors are oriented circumferentially about the trackball with approximately ninety degree spacing between consecutive sensors.

[0036] In accordance with the accompanying figures, exemplary embodiments of the handheld electronic device **300** are capable of reducing power consumption in a variety of ways, including adjusting the display properties and disabling power-consuming sensors **160**, **162**, **164**, **166** that detect motion of a ball **150** of the trackball navigation tool **328**. Reference numeral **300** is used throughout the disclo-

sure to generally refer to exemplary handheld devices, even where different specific embodiments are presented. Similarly, reference numerals **160**, **162**, **164**, and **166** are used throughout to refer to the sensors, even where different specific embodiments are being described, as is reference numeral **328**, among others.

[0037] As used herein, the term “handheld electronic device **300**” describes a relatively small device that is capable of being held in a user’s hand. It is a broader term that includes devices that are further classified as handheld communication devices **300**, which interact with a communications network **319**.

[0038] As depicted in FIG. 18, the handheld communication device **300** transmits data to and receives data from a communication network **319** utilizing radio frequency signals, the details of which are discussed more fully hereinbelow. Preferably, the data transmitted between the handheld communication device **300** and the communication network **319** supports voice and textual messaging, though it is contemplated that the method for reducing power consumption during periods of non-use is equally applicable to single mode devices; i.e., voice-only devices and text-only devices.

[0039] As may be appreciated from FIG. 1, the handheld electronic device **300** includes a lighted display **322** located above a keyboard **332** suitable for accommodating textual input to the handheld electronic device **300** when in an operable configuration. Preferably, the screen **322** and keyboard **332** are located at the front face of the handheld electronic device **300**. As shown, the device **300** is of unibody construction, but it is also contemplated that the device may be of an alternative construction such as that commonly known as “clamshell” or “flip-phone” style. Regardless, in operable configuration of the device **300**, the navigation tool (auxiliary input) **328** is located essentially between the display **322** and the keyboard **332**.

[0040] In one embodiment, the keyboard **332** comprises a plurality of keys with which alphabetic letters are associated on one-letter-per-key basis. It is contemplated that the keys may be directly marked with letters, or the letters may be presented adjacent, but clearly in association with a particular key. This one-to-one pairing between the letters and keys is depicted in FIGS. 12 and 13 and is described in greater detail below in association therewith. In order to facilitate user input, the alphabetic letters are preferably configured in a familiar QWERTY, QWERTZ, AZERTY, or Dvorak layout, each of which is also discussed in greater detail hereinbelow.

[0041] In the alternative embodiment of FIG. 1, the keyboard **332** comprises a plurality of keys with which alphabetic letters are also associated, but at least a portion of the individual keys have multiple letters associated therewith. This type of configuration is referred to as a reduced keyboard (in comparison to the full keyboard described immediately above) and can, among others come in QWERTY, QWERTZ, AZERTY, and Dvorak layouts.

[0042] As depicted in FIG. 1, the auxiliary input **328** is a trackball **150**. The trackball **150** is exposed for user manipulation at an exterior face of the device **300**. The ball **150** of the trackball navigation tool is freely rotatable. Motion of the trackball **150** is assessed using a plurality of sensors **160**, **162**, **164**, **166** that are positioned adjacent the trackball navigation tool **328** and determine increments of rotation of the ball **150** about a particular axis of rotation. In a preferred embodiment, the sensors **160**, **162**, **164**, **166** quantify rota-

tional motion of the trackball **150** about an x-axis **152** and an intersecting y-axis **154** of the trackball (see FIG. 2). The sensors **160**, **162**, **164**, **166** require power to be supplied to detect motion of the ball **150**. These sensors **160**, **162**, **164**, **166** further output a cursor control signal based upon the sensed motion of the ball **150**. Furthermore, the trackball **150** utilizes a sensor (not shown) to detect depression of the ball **150**.

[0043] As illustrated in FIG. 4, when non-use of the device **300** has been determined, the handheld electronic device **300** enters a power-saving mode. As an example, non-use of the device **300** is detected when neither the device’s applications nor its features have been utilized for a predetermined length of time. In yet another embodiment, the determination of non-use of the device **300** is based on a preselected period of time elapsing between sensor-detected movements of the ball **150** of the trackball navigation tool **328**. In another embodiment, a routine is used to detect when the device **300** is placed into an environment where use of the screen **322** and auxiliary input **328** is no longer required, such as when the device **300** is placed in a holster or pocket of the user. In yet another embodiment, the determination of non-use is based on user actuation of a preset key combination; preferably this is by depressing and holding the trackball navigation tool **328** for longer than a preset time period.

[0044] The key combination used to determine non-use of the device **300** can be preset or user definable. If a preset key combination is implemented, the keys used to indicate non-use are a set of keys that would not normally be entered by the user of the device **300**. The key combination may further involve selecting a feature from a menu of items or an icon on the home screen of the device **300**. The user defined key combination preferably informs the user that the device **300** is going into a non-use mode and allows exit thereof when the preset key combination is entered.

[0045] In one embodiment, the invention features a method for reducing power consumption during periods of non-use by the handheld electronic device **300**. This method involves a power-saving mode that disables a sensor **160**, **162**, **164**, **166** that, as described above is used to detect motion of the ball **150** of the trackball navigation tool **328**. Furthermore, the power consumption can further be reduced through the use of a display screen sleep mode. Preferably, the screen sleep mode is instituted before disablement of the sensors **160**, **162**, **164**, **166**. Thus, the power consumption is stepwise reduced in degree by an initial amount attributable to the institution of the display screen sleep mode. An incremental increase in power-savings is experienced by disabling the sensors **160**, **162**, **164**, **166**.

[0046] Implementation of the power-savings mode is further described in relation to the sensors **160**, **162**, **164**, **166**. When a device **300** implements one or more sensors **160**, **162**, **164**, **166** for detecting movement of the trackball **150**, power-savings can be realized through disabling one or more of the available sensors **160**, **162**, **164**, **166** on the device. Preferably, all sensors **160**, **162**, **164**, **166** are disabled. When the sensors **160**, **162**, **164**, **166** are disabled, rolling motion of the ball **150** will not cause an exit from the power-savings mode because no motion is recorded because the sensors **160**, **162**, **164**, **166** are disabled.

[0047] In a further embodiment, the method disables the display screen **322** of the handheld **300** before disabling the sensor **160**, **162**, **164**, **166**. This is referred to as a display

screen sleep mode which reduces the power consumed by the device 300 because the screen 322 is not consuming power. By first disabling the screen 322 and then disabling the sensor 160, 162, 164, 166 it is possible to allow for an exit from the display screen sleep mode by moving the ball 150 of the trackball navigation tool 328. Thus, when motion of the ball 150 is detected before the sensor 160, 162, 164, 166 is effected, an exit from power-saving mode is effected. This delay is appropriate to allow a user of the device 300 a chance to abort entry into a power-saving mode, which may not be desired at that time. Preferably, the user is informed of entry into this power-savings mode by having the display 322 disabled before the sensor 160, 162, 164, 166.

[0048] As further illustrated in FIG. 4, the screen sleep mode or power-saving mode can be exited through the use of a predefined routine. In a preferred embodiment, a preset wakeup key combination is used to restore the device 300 to a use-mode. This preset wakeup key combination can take the form of select button and "*" in sequential order. Another preferred key combination is depressing the trackball 150 and pressing "*" simultaneously or sequentially. Other key combinations are considered within the scope of this disclosure. Alternatively, the device 300 features a mechanism to detect the proximity of a human digit in relation to the trackball. When the digit is within a predefined distance from the trackball 150, the device 300 detects the presence of the digit and the device 300 exits the power-saving mode.

[0049] In another embodiment, a method for power consumption savings for a handheld electronic device 300 having a trackball navigation tool 328 is presented. This involves entering a screen sleep mode, receiving an input from one of the sensors 160, 162, 164, 166 associated with the trackball 150, and entering a low power display mode. This low power display mode utilizes the ability to reduce the intensity of the light of the screen 322 in order to save power. Thus after the screen 322 was put into a sleep mode in which the functionality of the device 300 continues to operate and only the screen 322 is turned off, a selection input will cause the screen 322 to enter the low power state where it does not return to full brightness.

[0050] The input from the sensor used to exit the screen sleep mode can be either a sensor 160, 162, 164, 166 or a selection sensor (not shown). Thus if a sensor 160, 162, 164, 166 is used to exit the screen sleep mode, a roll of the ball 150 such that it actuates one of the plurality of sensors 160, 162, 164, 166 will exit the screen sleep mode. However, if the input is from the selection sensor merely rolling the ball 150 will not exit the screen sleep mode. Using the selection sensor, will require a selection actuation of the navigation tool 328 in order to exit the screen sleep mode. Alternatively, other keys, combination of keys, combination of a key and navigation tool, or combination thereof may be used to exit the screen sleep mode.

[0051] In an exemplary embodiment, the method of going from a power save mode to a full power mode is shown. Once the power save mode has been activated either by the user of the device 300 or by the device 300 itself, the sensors 160, 162, 164, 166 are disabled. When a detection of either a key press or depression (selection operation) of the trackball 150 is made, the device is put into a low power mode. Alternatively, one of the above described inputs may be used to determine when to enter low power mode. Once the low

power mode has been entered, the sensors 160, 162, 164, 166 will be activated again. Once another actuation of the trackball 150 or keys is detected the device will then enter full power mode.

[0052] Yet another embodiment is a handheld electronic device 300 having a trackball navigation tool 328 and being adapted to reduce power consumption during periods of non-use. The trackball navigation tool 328 is the same as described above along with the sensor 160, 162, 164, 166, which is able to effect corresponding cursor movement on a display screen. The device 300 has a processor 338 that is capable of being programmed to reduce power consumption during periods of non-use by instituting a power-saving mode that disables the sensor 160, 162, 164, 166 when non-use of the device 300 is determined.

[0053] The handheld electronic device 300 in one embodiment makes use of a standby mode to save power. This mode can be entered either automatically by not detecting a level of activity for a given period of time or through a key sequence. Some of the examples of the key sequence that can be entered include depressing the power button for a short amount of time (not long enough to turn off the device) or depressing the mute key while not on a phone call. This standby mode can likewise be exited through the same set of key presses or a different set when standby mode is no longer desired.

[0054] When the device 300 has entered the standby mode, the screen 322 is put into a sleep mode in which the screen 322 is no longer illuminated. The screen 322 remains in this sleep mode unless the keys required to exit standby mode are depressed. When entering the standby mode, a message is presented on the display 322 informing the user that a standby mode is going to be entered and the key presses required to exit the mode. The device 300 will, however, continue to receive messages and phone calls. If a phone call is received by the device 300, it can be answered without exiting the standby mode or by temporarily disabling the standby mode. Once the phone call is finished the device 300 will again resume the standby mode.

[0055] If the device 300 is subsequently put into a holster, the device 300 will sense the holster position and this will override the standby mode. Thus, when the device 300 is holstered while in standby mode, it will respond based upon the holster settings for the device 300. When removed from the holster it will resume normal operation and ignore the earlier entered standby mode operation. Likewise, if the device 300 is placed into standby mode and the device 300 is also enabled with a security timeout mode, the device 300 will enter the security timeout mode at the appropriate time as controlled through the security timeout mode.

[0056] The motion of the navigation tool 328 commands a cursor to move on the display screen 322 of a handheld electronic device 300. While "cursor" movement is referred to herein, it shall be appreciated that any resultant motion that is directed by the navigation tool 328 is contemplated. Other such motions include but are not limited to scrolling down through a view on a webpage and scrolling through menu options. It should be appreciated that all such types of navigational motion on the display screen 322 is exemplarily described herein in terms of a cursor (such as a pointing arrow) movement across a display screen 322; however, those persons skilled in the art will also appreciate that "cursor" movement or navigation on a screen can also be

descriptive of successively highlighting presented menu items, screen icons and the like.

[0057] Further aspects of the environments, devices and methods of employment described hereinabove are expanded upon in the following details. An exemplary embodiment of the handheld electronic device **300** as shown in FIG. **1** can be cradled in the palm of a user's hand. The size of the device **300** is such that a user is capable of operating the device using the same hand that is holding the device. In a preferred embodiment, the user is capable of actuating all features of the device **300** using the thumb of the cradling hand. While in other embodiments, features may require the use of more than just the thumb of the cradling hand. The preferred embodiment of the handheld device **300** features a keyboard **332** on the face of the device **300**, which is actuable by the thumb of the hand cradling the device **300**. The user may also hold the device **300** in such a manner to enable two thumb typing on the device **300**. Furthermore, the user may use fingers rather than thumbs to actuate the keys on the device **300**. In order to accommodate palm-cradling of the device **300** by the average person, it is longer (height as shown in FIG. **1**) than it is wide, and the width is preferably between approximately two and three inches, but by no means limited to such dimensions.

[0058] The handheld electronic device **300** includes an input portion and an output display portion. The output display portion can be a display screen **322**, such as an LCD or other similar display device.

[0059] The input portion includes a plurality of keys that can be of a physical nature such as actuable buttons or they can be of a software nature, typically constituted by virtual representations of physical keys on a display screen (referred to herein as "software keys"). It is also contemplated that the user input can be provided as a combination of the two types of keys. Each key of the plurality of keys has at least one actuable action which can be the input of a character, a command or a function. In this context, "characters" are contemplated to exemplarily include alphabetic letters, language symbols, numbers, punctuation, insignias, icons, pictures, and even a blank space. Input commands and functions can include such things as delete, backspace, moving a cursor up, down, left or right, initiating an arithmetic function or command, initiating a command or function specific to an application program or feature in use, initiating a command or function programmed by the user and other such commands and functions that are well known to those persons skilled in the art. Specific keys or other types of input devices can be used to navigate through the various applications and features thereof. Further, depending on the application or feature in use, specific keys can be enabled or disabled.

[0060] In the case of physical keys, all or a portion of the plurality of keys have one or more indicia displayed at their top surface and/or on the surface of the area adjacent the respective key, the particular indicia representing the character(s), command(s) and/or function(s) typically associated with that key. In the instance where the indicia of a key's function is provided adjacent the key, it is understood that this may be a permanent insignia that is, for instance, printed on the device cover beside the key, or in the instance of keys located adjacent the display screen, a current indicia for the key may be temporarily shown nearby the key on the screen.

[0061] In the case of software keys, the indicia for the respective keys are shown on the display screen, which in

one embodiment is enabled by touching the display screen, for example, with a stylus to generate the character or activate the indicated command or function. Such display screens may include one or more touch interfaces, including a touchscreen. A non-exhaustive list of touchscreens includes, for example, resistive touchscreens, capacitive touchscreens, projected capacitive touchscreens, infrared touchscreens and surface acoustic wave (SAW) touchscreens.

[0062] Physical and software keys can be combined in many different ways as appreciated by those skilled in the art. In one embodiment, physical and software keys are combined such that the plurality of enabled keys for a particular application or feature of the handheld electronic device **300** is shown on the display screen **322** in the same configuration as the physical keys. Thus, the desired character, command or function is obtained by depressing the physical key corresponding to the character, command or function displayed at a corresponding position on the display screen, rather than touching the display screen **322**. To aid the user, indicia for the characters, commands and/or functions most frequently used are preferably positioned on the physical keys and/or on the area around or between the physical keys. In this manner, the user can more readily associate the correct physical key with the character, command or function displayed on the display screen **322**.

[0063] The various characters, commands and functions associated with keyboard typing in general are traditionally arranged using various conventions. The most common of these in the United States, for instance, is the QWERTY keyboard layout. Others include the QWERTZ, AZERTY, and Dvorak keyboard configurations of the English-language alphabet.

[0064] The QWERTY keyboard layout is the standard English-language alphabetic key arrangement **44** (see FIG. **5**). In this configuration, Q, W, E, R, T and Y are the letters on the top left, alphabetic row. It was designed by Christopher Sholes, who invented the typewriter. The keyboard layout was organized by him to prevent people from typing too fast and jamming the keys. The QWERTY layout was included in the drawing for Sholes' patent application in 1878.

[0065] The QWERTZ keyboard layout is normally used in German-speaking regions. This alphabetic key arrangement **44** is shown in FIG. **6**. In this configuration, Q, W, E, R, T and Z are the letters on the top left, alphabetic row. It differs from the QWERTY keyboard layout by exchanging the "Y" with a "Z". This is because "Z" is a much more common letter than "Y" in German and the letters "T" and "Z" often appear next to each other in the German language.

[0066] The AZERTY keyboard layout is normally used in French-speaking regions. This alphabetic key arrangement **44** is shown in FIG. **7**. In this configuration, A, Z, E, R, T and Y are the letters on the top left, alphabetic row. It is similar to the QWERTY layout, except that the letters Q and A are swapped, the letters Z and W are swapped, and the letter M is in the middle row instead of the bottom one.

[0067] The Dvorak keyboard layout was designed in the 1930s by August Dvorak and William Dealey. This alphabetic key arrangement **44** is shown in FIG. **8**. It was developed to allow a typist to type faster. About 70% of words are typed on the home row compared to about 32% with a QWERTY keyboard layout, and more words are

typed using both hands. It is said that in eight hours, fingers of a QWERTY typist travel about 16 miles, but only about 1 mile for the Dvorak typist.

[0068] Alphabetic key arrangements in full keyboards and typewriters are often presented along with numeric key arrangements. An exemplary numeric key arrangement is shown in FIGS. 5-8 where the numbers 1-9 and 0 are positioned above the alphabetic keys. In another known numeric key arrangement, numbers share keys with the alphabetic characters, such as the top row of the QWERTY keyboard. Yet another exemplary numeric key arrangement is shown in FIG. 9, where a numeric keypad 46 is spaced from the alphabetic/numeric key arrangement. The numeric keypad 46 includes the numbers "7", "8", "9" arranged in a top row, "4", "5", "6" arranged in a second row, "1", "2", "3" arranged in a third row, and "0" in a bottom row, consistent with what may be found on a known "ten-key" computer keyboard keypad. Additionally, a numeric phone key arrangement 42 is also known, as shown in FIG. 10.

[0069] As shown in FIG. 10, the numeric phone key arrangement 42 may also utilize a surface treatment on the surface of the center "5" key. This surface treatment is such that the surface of the key is distinctive from the surface of other keys. Preferably the surface treatment is in the form of a raised bump or recessed dimple 43. This bump or dimple 43 is typically standard on telephones and is used to identify the "5" key through touch alone. Once the user has identified the "5" key, it is possible to identify the remainder of the phone keys through touch alone because of their standard placement. The bump or dimple 43 preferably has a shape and size that is readily evident to a user through touch. An example bump or dimple 43 may be round, rectangular, or have another shape if desired. Alternatively, raised bumps may be positioned on the housing around the "5" key and do not necessarily have to be positioned directly on the key, as known by those of skill in the art.

[0070] Handheld electronic devices 300 that include a combined text-entry keyboard and a telephony keyboard are also known. Examples of such mobile communication devices include mobile stations, cellular telephones, wireless personal digital assistants (PDAs), two-way paging devices, and others. Various keyboards are used with such devices depending in part on the physical size of the handheld electronic device 300. Some of these are termed full keyboard, reduced keyboard, and phone key pads.

[0071] In embodiments of a handheld electronic device 300 having a full keyboard, only one alphabetic character is associated with each one of a plurality of physical keys. Thus, with an English-language keyboard, there are at least 26 keys in the plurality, one for each letter of the English alphabet. In such embodiments using the English-language alphabet, one of the keyboard layouts described above is usually employed, and with the QWERTY keyboard layout being the most common.

[0072] One device that uses a full keyboard for alphabetic characters and incorporates a combined numeric keyboard is shown in FIG. 12. In this device, numeric characters share keys with alphabetic characters on the top row of the QWERTY keyboard. Another device that incorporates a combined alphabetic/numeric keyboard is shown in FIG. 13. This device utilizes numeric characters in a numeric phone key arrangement consistent with the ITU Standard E.161, as shown in FIG. 10. The numeric characters share keys with alphabetic characters on the left side of the keyboard.

[0073] In order to further reduce the size of a handheld electronic device 300 without making the physical keys or software keys too small, some handheld electronic devices 300 use a reduced keyboard, where more than one character/command/function is associated with each of at least a portion of the plurality of keys. This results in certain keys being ambiguous since more than one character is represented by or associated with the key, even though only one of those characters is typically intended by the user when activating the key.

[0074] Thus, certain software usually runs on the processor of these types of handheld electronic device 300 to determine or predict what letter or word has been intended by the user. Predictive text technologies can also automatically correct common spelling errors. Predictive text methodologies often include a disambiguation engine and/or a predictive editor application. This helps facilitate easy spelling and composition, since the software is preferably intuitive software with a large word list and the ability to increase that list based on the frequency of word usage. The software preferably also has the ability to recognize character letter sequences that are common to the particular language, such as, in the case of English, words ending in "ing." Such systems can also "learn" the typing style of the user making note of frequently used words to increase the predictive aspect of the software. With predictive editor applications, the display of the device depicts possible character sequences corresponding to the keystrokes that were entered. Typically, the most commonly used word is displayed first. The user may select other, less common words manually, or otherwise. Other types of predictive text computer programs may be utilized with the keyboard arrangement and keyboard described herein, without limitation.

The multi-tap method of character selection has been in use a number of years for permitting users to enter text using a touch screen device or a conventional telephone key pad such as specified under ITU E 1.161, among other devices. Multi-tap requires a user to press a key a varying number of times, generally within a limited period of time, to input a specific letter, thereby spelling the desired words of the message. A related method is the long tap method, where a user depresses the key until the desired character appears on the display out of a rotating series of letters.

[0075] A "text on nine keys" type system uses predictive letter patterns to allow a user to ideally press each key representing a letter only once to enter text. Unlike multi-tap which requires a user to indicate a desired character by a precise number of presses of a key, or keystrokes, the "text-on-nine-keys" system uses a predictive text dictionary and established letter patterns for a language to intelligently guess which one of many characters represented by a key that the user intended to enter. The predictive text dictionary is primarily a list of words, acronyms, abbreviations and the like that can be used in the composition of text.

[0076] Generally, all possible character string permutations represented by a number of keystrokes entered by a user are compared to the words in the predictive text dictionary and a subset of the permutations is shown to the user to allow selection of the intended character string. The permutations are generally sorted by likelihood of occurrence which is determined from the number of words matched in the predictive text dictionary and various metrics maintained for these words. Where the possible character string permutations do not match any words in the predictive

text dictionary, the set of established letter patterns for a selected language can be applied to suggest the most likely character string permutations, and then require the user to input a number of additional keystrokes in order to enter the desired word.

[0077] The keys of reduced keyboards are laid out with various arrangements of characters, commands and functions associated therewith. In regards to alphabetic characters, the different keyboard layouts identified above are selectively used based on a user's preference and familiarity; for example, the QWERTY keyboard layout is most often used by English speakers who have become accustomed to the key arrangement.

[0078] FIG. 14 shows a handheld electronic device 300 that carries an example of a reduced keyboard using the QWERTY keyboard layout on a physical keyboard array of twenty keys comprising five columns and four rows. Fourteen keys are used for alphabetic characters and ten keys are used for numbers. Nine of the ten numbers share a key with alphabetic characters. The "space" key and the number "0" share the same key, which is centered on the device and centered below the remainder of the numbers on the keyboard 332. The four rows include a first row 50, a second row 52, a third row 54, and a fourth row 56. The five columns include a first column 60, a second column 62, a third column 64, a fourth column 66, and a fifth column 68. Each of the keys in the first row 50, second row 52, and third row 54 is uniformly sized while the keys in the fourth, bottom row 56 have different sizes relative to one another and to the keys in the first three rows 50, 52, 54. The rows and columns are straight, although the keys in the fourth row 56 do not align completely with the columns because of their differing sizes. The columns substantially align with the longitudinal axis x-x of the device 300.

[0079] FIG. 15 shows a handheld electronic device 300 that has an example physical keyboard array of twenty keys, with five columns and four rows. A detailed view of the keyboard 332 is presented in FIG. 16. Fourteen keys on the keyboard 332 are associated with alphabetic characters and ten keys are associated with numbers. The four rows include a first row 50, a second row 52, a third row 54, and a fourth row 56. The five columns include a first column 60, a second column 62, a third column 64, a fourth column 66, and a fifth column 68. Many of the keys have different sizes than the other keys, and the rows are non-linear. In particular, the rows are V-shaped, with the middle key in the third column 64 representing the point of the V. The columns are generally straight, but the outer two columns 60, 62, 66, 68 angle inwardly toward the middle column 64. To readily identify the phone user interface (the second user interface), the numeric phone keys 0-9 include a color scheme that is different from that of the remaining keys associated with the QWERTY key arrangement.

[0080] In this example, the color scheme of the numeric phone keys has a two tone appearance, with the upper portion of the numeric keys being a first color and the lower portion of the numeric keys being a second color. In the example, the upper portion of the keys is white with blue letters and the lower portion of the keys is blue with white letters. Most of the remaining keys associated with the QWERTY key arrangement are predominantly the second, blue color with white lettering. The first color may be lighter than the second color, or darker than the second color. In addition, the keyboard 332 includes a "send" key 6 and an

"end" key 8. The "send" key 6 is positioned in the upper left corner of the keyboard 332 and the "end" key 8 is positioned in the upper right corner. The "send" key 6 and "end" key 8 may have different color schemes than the remainder of the keys in order to distinguish them from other keys. In addition, the "send" and "end" keys 6, 8 may have different colors from one another. In the example shown, the "send" key 6 is green and the "end" key 8 is red. Different colors may be utilized, if desired.

[0081] FIG. 17 shows a similar format for the reduced QWERTY arrangement of alphabetic characters 44 as presented in FIG. 14, but the numeric phone key arrangement 42 is positioned in the first 60, second 62, and third 64 columns instead of being centered on the keyboard 332. The first row 50 of keys includes in order the following key combinations for the text entry and telephony mode: "QW/1", "ER/2", "TY/3", "UI", and "OP". The second row 52 includes the following key combinations in order: "AS/4", "DF/51", "GH/6", "JK/," and "L/.". The third row 54 includes the following key combinations in order: "ZX/7", "CV/8", "BN/9", "M/sym" and "backspace/delete". The fourth row 56 includes the following key combinations in order: "next/*", "space/0", "shift/#", "alt" and "return/enter". The keys in each of the rows are of uniform size and the rows and columns are straight.

[0082] Another embodiment of a reduced alphabetic keyboard is found on a standard phone keypad. Most handheld electronic devices 300 having a phone key pad also typically include alphabetic key arrangements overlaying or coinciding with the numeric keys as shown in FIG. 11. Such alphanumeric phone keypads are used in many, if not most, traditional handheld telephony mobile communication devices such as cellular handsets.

[0083] As described above, the International Telecommunications Union ("ITU") has established phone standards for the arrangement of alphanumeric keys. The standard phone numeric key arrangement shown in FIGS. 10 (no alphabetic letters) and 11 (with alphabetic letters) corresponds to ITU Standard E.161, entitled "Arrangement of Digits, Letters, and Symbols on Telephones and Other Devices That Can Be Used for Gaining Access to a Telephone Network." This standard is also known as ANSI T1.703-1995/1999 and ISO/IEC 9995-8:1994. Regarding the numeric arrangement, it can be aptly described as a top-to-bottom ascending order three-by-three-over-zero pattern.

[0084] The table below identifies the alphabetic characters associated with each number for some other phone keypad conventions.

Number on Key	Mobile Phone Keypad				
	ITU E.161	Australia	#1	#11 (Europe)	#111 (Europe)
1		QZ		ABC	ABC
2	ABC	ABC	ABC	DEF	DEF
3	DEF	DEF	DEF	GHI	GHI
4	GHI	GHI	GHI	JKL	JKL
5	JKL	JKL	JKL	MNO	MNO
6	MNO	MNO	MN	PQR	PQR
7	PQRS	PRS	PRS	STU	STU
8	TUV	TUV	TUV	UVW	VWX
9	WXYZ	WXY	WXY	XYZ	YZ
0			OQZ		

[0085] It should also be appreciated that other alphabetic character and number combinations can be used beyond those identified above when deemed useful to a particular application.

[0086] As noted earlier, multi-tap software has been in use for a number of years permitting users to enter text using a conventional telephone key pad such as specified under ITU E 1.161 or on a touch screen display, among other devices. Multi-tap requires a user to press a key a varying number of times, generally within a limited period of time, to input a specific letter associated with the particular key, thereby spelling the desired words of the message. A related method is the long tap method, where a user depresses the key until the desired character appears on the display.

[0087] An exemplary handheld electronic device 300 is shown in the assembly drawing of FIG. 3 and its cooperation in a wireless network is exemplified in the block diagram of FIG. 18. These figures are exemplary only, and those persons skilled in the art will appreciate the additional elements and modifications necessary to make the device work in particular network environments.

[0088] FIG. 3 is an exploded view showing some of the typical components found in the assembly of the handheld electronic device 300. The construction of the device benefits from various manufacturing simplifications. The internal components are constructed on a single PCB (printed circuit board) 102. The keyboard 332 is constructed from a single piece of material, and in a preferred embodiment is made from plastic. The keyboard 332 sits over dome switches (not shown) located on the PCB 102 in a preferred embodiment. One switch is provided for every key on the keyboard in the preferred embodiment, but in other embodiments more than one switch or less than one switch per key are possible configurations. The support frame 101 holds the keyboard 332 and navigation tool 328 in place above the PCB 102. The support frame 101 also provides an attachment point for the display (not shown). A lens 103 covers the display to prevent damage. When assembled, the support frame 101 and the PCB 102 are fixably attached to each other and the display is positioned between the PCB 102 and support frame 101.

[0089] The navigation tool 328 is frictionally engaged with the support frame 101, but in a preferred embodiment the navigation tool 328 is removable when the device is assembled. This allows for replacement of the navigation tool 328 if it becomes damaged or the user desires replacement with a different type of navigation tool 328. In the exemplary embodiment of FIG. 3, the navigation tool 328 is a trackball 150 based device. When the navigation tool 328 has a trackball 150, the trackball 150 itself can be removed without removal of the navigation tool 328. The removal of the trackball 150 is enabled through the use of an outer removable ring 123 and an inner removable ring 122. These rings 122, 123 ensure that the navigation tool 328 and the trackball 150 are properly held in place against the support frame 101.

[0090] A serial port (preferably a Universal Serial Bus port) 330 and an earphone jack 140 are fixably attached to the PCB 102 and further held in place by right side element 105. Buttons 130, 131, 132, 133 are attached to switches (not shown), which are connected to the PCB 102.

[0091] Final assembly involves placing the top piece 107 and bottom piece 108 in contact with support frame 101. Furthermore, the assembly interconnects right side element

105 and left side element 106 with the support frame 101, PCB 102, and lens 103. These side elements 105, 106 provide additional protection and strength to the support structure of the device 300. In a preferred embodiment, backplate 104 is removably attached to the other elements of the device.

[0092] The block diagram of FIG. 18, representing the communication device 300 interacting in the communication network 319, shows the device's 300 inclusion of a microprocessor 338 which controls the operation of the device 300. The communication subsystem 311 performs all communication transmission and reception with the wireless network 319. The microprocessor 338 further connects with an auxiliary input/output (I/O) subsystem 328, a serial port (preferably a Universal Serial Bus port) 330, a display 322, a keyboard 332, a speaker 334, a microphone 336, random access memory (RAM) 326, and flash memory 324. Other communications subsystems 340 and other device subsystems 342 are generally indicated as connected to the microprocessor 338 as well. An example of a communication subsystem 340 is that of a short range communication subsystem such as BLUETOOTH® communication module or an infrared device and associated circuits and components. Additionally, the microprocessor 338 is able to perform operating system functions and preferably enables execution of software applications on the communication device 300.

[0093] The above described auxiliary I/O subsystem 328 can take a variety of different subsystems including the above described navigation tool 328. As previously mentioned, the navigation tool 328 is preferably a trackball based device, but it can be any one of the other above described tools. Other auxiliary I/O devices can include external display devices and externally connected keyboards (not shown). While the above examples have been provided in relation to the auxiliary I/O subsystem, other subsystems capable of providing input or receiving output from the handheld electronic device 300 are considered within the scope of this disclosure.

[0094] In a preferred embodiment, the communication device 300 is designed to wirelessly connect with a communication network 319. Some communication networks that the communication device 300 may be designed to operate on require a subscriber identity module (SIM) or removable user identity module (RUIM). Thus, a device 300 intended to operate on such a system will include SIM/RUIM interface 344 into which the SIM/RUIM card (not shown) may be placed. The SIM/RUIM interface 344 can be one in which the SIM/RUIM card is inserted and ejected.

[0095] In an exemplary embodiment, the flash memory 324 is enabled to provide a storage location for the operating system, device programs, and data. While the operating system in a preferred embodiment is stored in flash memory 324, the operating system in other embodiments is stored in read-only memory (ROM) or similar storage element (not shown). As those skilled in the art will appreciate, the operating system, device application or parts thereof may be loaded in RAM 326 or other volatile memory.

[0096] In a preferred embodiment, the flash memory 324 contains programs/applications 358 for execution on the device 300 including an address book 352, a personal information manager (PIM) 354, and the device state 350. Furthermore, programs 358 and other information 356 can be segregated upon storage in the flash memory 324 of the

device 300. However, another embodiment of the flash memory 324 utilizes a storage allocation method such that a program 358 is allocated additional space in order to store data associated with such program. Other known allocation methods exist in the art and those persons skilled in the art will appreciate additional ways to allocate the memory of the device 300.

[0097] In a preferred embodiment, the device 300 is pre-loaded with a limited set of programs that enable it to operate on the communication network 319. Another program that can be preloaded is a PIM 354 application that has the ability to organize and manage data items including but not limited to email, calendar events, voice messages, appointments and task items. In order to operate efficiently, memory 324 is allocated for use by the PIM 354 for the storage of associated data. In a preferred embodiment, the information that PIM 354 manages is seamlessly integrated, synchronized and updated through the communication network 319 with a user's corresponding information on a remote computer (not shown). The synchronization, in another embodiment, can also be performed through the serial port 330 or other short range communication subsystem 340. Other applications may be installed through connection with the wireless network 319, serial port 330 or via other short range communication subsystems 340.

[0098] When the device 300 is enabled for two-way communication within the wireless communication network 319, it can send and receive signals from a mobile communication service. Examples of communication systems enabled for two-way communication include, but are not limited to, the GPRS (General Packet Radio Service) network, the UMTS (Universal Mobile Telecommunication Service) network, the EDGE (Enhanced Data for Global Evolution) network, and the CDMA (Code Division Multiple Access) network and those networks generally described as packet-switched, narrowband, data-only technologies mainly used for short burst wireless data transfer.

[0099] For the systems listed above, the communication device 300 must be properly enabled to transmit and receive signals from the communication network 319. Other systems may not require such identifying information. A GPRS, UMTS, and EDGE require the use of a SIM (Subscriber Identity Module) in order to allow communication with the communication network 319. Likewise, most CDMA systems require the use of a RUIM (Removable Identity Module) in order to communicate with the CDMA network. The RUIM and SIM card can be used in multiple different communication devices 300. The communication device 300 may be able to operate some features without a SIM/RUIM card, but it will not be able to communicate with the network 319. In some locations, the communication device 300 will be enabled to work with special services, such as "911" emergency, without a SIM/RUIM or with a non-functioning SIM/RUIM card. A SIM/RUIM interface 344 located within the device allows for removal or insertion of a SIM/RUIM card (not shown). This interface 344 can be configured like that of a disk drive or a PCMCIA slot or other known attachment mechanism in the art. The SIM/RUIM card features memory and holds key configurations 351, and other information 353 such as identification and subscriber related information. Furthermore, a SIM/RUIM card can be enabled to store information about the user including identification, carrier and address book information. With a properly enabled communication device 300,

two-way communication between the communication device 300 and communication network 319 is possible.

[0100] If the communication device 300 is enabled as described above or the communication network 319 does not require such enablement, the two-way communication enabled device 300 is able to both transmit and receive information from the communication network 319. The transfer of communication can be from the device 300 or to the device 300. In order to communicate with the communication network 319, the device 300 in a preferred embodiment is equipped with an integral or internal antenna 318 for transmitting signals to the communication network 319. Likewise the communication device 300 in the preferred embodiment is equipped with another antenna 316 for receiving communication from the communication network 319. These antennae 316, 318 in another preferred embodiment are combined into a single antenna (not shown). As one skilled in the art would appreciate, the antenna or antennae 316, 318 in another embodiment are externally mounted on the device 300.

[0101] When equipped for two-way communication, the communication device 300 features a communication subsystem 311. As is well known in the art, this communication subsystem 311 is modified so that it can support the operational needs of the device 300. The subsystem 311 includes a transmitter 314 and receiver 312 including the associated antenna or antennae 316, 318 as described above, local oscillators (LOs) 313, and a processing module 320 which in a preferred embodiment is a digital signal processor (DSP) 320.

[0102] A signal received by the communication device 300 is first received by the antenna 316 and then input into a receiver 312, which in a preferred embodiment is capable of performing common receiver functions including signal amplification, frequency down conversion, filtering, channel selection and the like, and analog to digital (A/D) conversion. The A/D conversion allows the DSP 320 to perform more complex communication functions such as demodulation and decoding on the signals that are received by DSP 320 from the receiver 312. The DSP 320 is also capable of issuing control commands to the receiver 312. An example of a control command that the DSP 320 is capable of sending to the receiver 312 is gain control, which is implemented in automatic gain control algorithms implemented in the DSP 320. Likewise, the communication device 300 is capable of transmitting signals to the communication network 319. The DSP 320 communicates the signals to be sent to the transmitter 314 and further communicates control functions, such as the above described gain control. The signal is emitted by the device 300 through an antenna 318 connected to the transmitter 314.

[0103] It is contemplated that communication by the device 300 with the wireless network 319 can be any type of communication that both the wireless network 319 and device 300 are enabled to transmit, receive and process. In general, these can be classified as voice and data. Voice communication is communication in which signals for audible sounds are transmitted by the device 300 through the communication network 319. Data is all other types of communication that the device 300 is capable of performing within the constraints of the wireless network 319.

[0104] In the instance of voice communications, voice transmissions that originate from the communication device 300 enter the device 300 through a microphone 336. The

microphone 336 communicates the signals to the microprocessor 338 for further conditioning and processing. The microprocessor 338 sends the signals to the DSP 320 which controls the transmitter 314 and provides the correct signals to the transmitter 314. Then, the transmitter 314 sends the signals to the antenna 318, which emits the signals to be detected by a communication network 319. Likewise, when the receiver 312 obtains a signal from the receiving antenna 316 that is a voice signal, it is transmitted to the DSP 320 which further sends the signal to the microprocessor 338. Then, the microprocessor 338 provides a signal to the speaker 334 of the device 300 and the user can hear the voice communication that has been received. The device 300 in a preferred embodiment is enabled to allow for full duplex voice transmission.

[0105] In another embodiment, the voice transmission may be received by the communication device 300 and translated as text to be shown on the display screen 322 of the communication device 300. The communication device 300 is also capable of retrieving messages from a voice messaging service operated by the communication network operator. In a preferred embodiment, the device 300 displays information in relation to the voice message, such as the number of voice messages or an indication that a new voice message is present on the operating system.

[0106] In a preferred embodiment, the display 322 of the communication device 300 provides an indication about the identity of an incoming call, duration of the voice communication, telephone number of the communication device, call history, and other related information. It should be appreciated that the above described embodiments are given as examples only and one skilled in the art may effect alterations, modifications and variations to the particular embodiments without departing from the scope of the application.

[0107] As stated above, the communication device 300 and communication network 319 can be enabled to transmit, receive and process data. Several different types of data exist and some of these types of data will be described in further detail. One type of data communication that occurs over the communication network 319 includes electronic mail (email) messages. Typically an email is text based, but can also include other types of data such as picture files, attachments and html. While these are given as examples, other types of messages are considered within the scope of this disclosure as well.

[0108] When the email originates from a source outside of the device and is communicated to the device 300, it is first received by the receiving antenna 316 and then transmitted to the receiver 312. From the receiver 312, the email message is further processed by the DSP 320, and it then reaches the microprocessor 338. The microprocessor 338 executes instructions as indicated from the relevant programming instructions to display, store or process the email message as directed by the program. In a similar manner, once an email message has been properly processed by the microprocessor 338 for transmission to the communication network 319, it is first sent to the DSP 320, which further transmits the email message to the transmitter 314. The transmitter 314 processes the email message and transmits it to the transmission antenna 318, which broadcasts a signal to be received by a communication network 319. While the above has been described generally, those skilled in this art will appreciate those modifications which are necessary to

enable the communication device 300 to properly transmit the email message over a given communication network 319.

[0109] Furthermore, the email message may instead be transmitted from the device 300 via a serial port 330, another communication port 340, or other wireless communication ports 340. The user of the device 300 can generate a message to be sent using the keyboard 332 and/or auxiliary I/O 328, and the associated application to generate the email message. Once the email message is generated, the user may execute a send command which directs the email message from the communication device 300 to the communication network 319. In an exemplary embodiment, a keyboard 332, preferably an alphanumeric keyboard, is used to compose the email message. In a preferred embodiment, an auxiliary I/O device 328 is used in addition to the keyboard 332.

[0110] While the above has been described in relation to email messages, one skilled in the art could easily modify the procedure to function with other types of data such as SMS text messages, internet websites, videos, instant messages, programs and ringtones. Once the data is received by the microprocessor 338, the data is placed appropriately within the operating system of the device 300. This might involve presenting a message on the display 322 which indicates the data has been received or storing it in the appropriate memory 324 on the device 300. For example, a downloaded application such as a game will be placed into a suitable place in the flash memory 324 of the device 300. The operating system of the device 300 will also allow for appropriate access to the new application as downloaded.

[0111] Exemplary embodiments have been described hereinabove regarding handheld electronic devices 300 and wireless handheld communication devices 300 as well as the communication networks within which they cooperate. It should be appreciated, however, that a focus of the present disclosure is the enablement of power-saving mode for a handheld electronic device 300.

What is claimed is:

1. A method for reducing power consumption during periods of non-use by a handheld electronic device having a trackball navigation tool exposed at a face thereof, said method comprising effecting a power-saving mode by disabling a power-consuming sensor that detects motion of a ball of the trackball navigation tool when non-use of the device is determined.
2. The method of claim 1, wherein said determination of non-use of the device is based on a preselected period of time elapsing between sensor-detected movements of the ball of the trackball navigation tool.
3. The method of claim 1, wherein said determination of non-use of the device is based on user actuation of a preset key combination.
4. The method of claim 3, wherein said actuation of a preset key combination comprises depressing and holding the ball of the ball of the trackball navigation tool for longer than a preset time period.
5. The method of claim 1, wherein the power-consuming sensor is one of a plurality of power-consuming sensors, each of which is positioned adjacent the trackball navigation tool for determining increments of rotation of the ball of the tool about a particular axis of rotation.
6. The method of claim 5, wherein each of the power-consuming sensors is a hall effect sensor.

7. The method of claim 5, wherein the plurality of power-consuming sensors number four and are arranged at ninety degree intervals about the trackball navigation tool.

8. The method of claim 1, wherein disabling the power-consuming sensor is effected by removing power supplied thereto and thereby reducing power consumption by the device.

9. The method of claim 1, further comprising disabling a display screen of the handheld electronic device upon entering the power-saving mode and thereby reducing power consumption by the device.

10. The method of claim 1, further comprising disabling a display screen of the handheld electronic device upon entering the power-saving mode and before disabling the power-consuming sensor thereby instituting a display screen sleep mode which reduces power consumption by the device.

11. The method of claim 10, further comprising exiting the display screen sleep mode when motion of the ball of the trackball navigation tool is detected before disablement of the power-consuming sensor is effected.

12. The method of claim 10, wherein power consumption is stepwise reduced in degree with an initial amount of power-savings being experienced from the institution of the display screen sleep mode and an incremental increase in power-savings being experienced when the power-consuming sensor is disabled.

13. The method of claim 1, further comprising restoring the device to a use-mode in response to user actuation of a preset wakeup key combination.

14. The method of claim 5, wherein said plurality of power-consuming sensors produce x-direction signals and y-direction signals based on sensed movement of the ball of the trackball navigation tool and a processor analyzes the produced x-direction signals and y-direction signals and outputs a cursor control signal based thereupon.

15. The method of claim 14, wherein said each of the power-consuming sensors is a hall effect sensor.

16. The method of claim 1, wherein said device further comprises a radio transmitter capable of transmitting data to a communication network utilizing radio frequency signals and a radio receiver capable of receiving data from the communication network utilizing radio frequency signals.

17. A handheld electronic device, comprising:

a trackball navigation tool having a freely rotatable ball exposed for user manipulation at an exterior face of the device;

a power-consuming sensor capable of sensing movement of the ball of the trackball navigation tool indicative of the user's desire to effect corresponding cursor movement on a display screen of the device; and

a processor programmed to reduce power consumption during periods of device non-use by instituting a power-saving mode that disables the sensor when non-use of the device is determined.

18. The device of claim 17, further comprising:

a keyboard suitable for accommodating textual input to the handheld electronic device located beneath a lighted display screen, said screen and said keyboard being located at a front face of said device; and said trackball navigation tool being located essentially between the display and the keyboard.

19. The device of claim 17, wherein said determination of non-use of the device is based on a preselected period of time elapsing between sensor-detected movements of the ball of the trackball navigation tool.

20. The device of claim 17, wherein said determination of non-use of the device is based on user actuation of a preset key combination.

21. The device of claim 20, wherein said actuation of the preset key combination comprises depressing and holding the trackball navigation tool for longer than a preset time period.

22. The device of claim 17, wherein the sensor is one of a plurality of sensors, each of which is positioned adjacent the trackball navigation tool for determining increments of rotation of the ball of the tool about a particular axis of rotation.

23. The device of claim 22, wherein said each of the power-consuming sensors is a hall effect sensor.

24. The device of claim 22, wherein the plurality of power-consuming sensors number four and are arranged at ninety degree intervals about the trackball navigation tool.

25. The device of claim 17, wherein disabling the power-consuming sensor is effected by removing power supplied thereto and thereby reducing power consumption by the device.

26. The device of claim 17, further comprising disabling a display screen of the handheld electronic device upon entering the power-saving mode and thereby reducing power consumption by the device.

27. The device of claim 17, further comprising disabling said lighted display screen of the handheld electronic device upon entering the power-saving mode and before disabling the power-consuming sensor thereby instituting a display screen sleep mode which reduces power consumption by the device.

28. The device of claim 27, further comprising exiting the display screen sleep mode when motion of the ball of the trackball navigation tool is detected before disablement of the power-consuming sensor is effected.

29. The device of claim 27, wherein the power consumption is stepwise reduced in degree with an initial amount of power-savings being experienced from the institution of the display screen sleep mode and an incremental increase in power-savings being experienced when the power-consuming sensor is disabled.

30. The device of claim 17, further comprising restoring the device to a use-mode based on user actuation of a preset wakeup key combination.

31. The device of claim 22, wherein said plurality of the power-consuming sensors produce x-direction signals and y-direction signals based on sensed movement of the ball of the trackball navigation tool and a processor analyzes the produced x-direction signals and y-direction signals and outputs a cursor control signal based thereupon.

32. The device of claim 31, wherein said each of the power-consuming sensors is a hall effect sensor.

33. The device of claim 17, further comprising a radio transmitter capable of transmitting data to a communication network utilizing radio frequency signals and a radio receiver capable of receiving data from the communication network utilizing radio frequency signals.