

AUSTRALIA

Patents Act 1990

660816

REQUEST FOR A STANDARD PATENT

AND NOTICE OF ENTITLEMENT

The Applicant identified below requests the grant of a patent to the nominated person identified below for an invention described in the accompanying standard complete patent specification.

[70,71]Applicant and Nominated Person:

Zarina Holding CV
Leidsplein 29, 1017 PS Amsterdam, THE NETHERLANDS

[54]Invention Title:

FILTER

[72]Actual Inventors:

David Seagrave Atkins

[74]Address for Service:

PHILLIPS ORMONDE & FITZPATRICK
367 Collins Street
Melbourne 3000 AUSTRALIA

[31,33,32]

Details of basic application(s):-

92/5043	SOUTH AFRICA	ZA	7 July 1992
92/8987	SOUTH AFRICA	ZA	20 November 1992

Applicant states the following:

1. The nominated person is the assignee of the actual inventor(s)
2. The nominated person is
 - the applicant
 - ~~- the assignee of the applicant -~~
 - ~~- authorised to make this application by the applicant -~~
 of the basic application.
3. The basic application(s) ~~was/were~~ the first made in a convention country in respect of the invention.

The nominated person is not an opponent or eligible person described in Section 33-36 of the Act.

6 July 1993

Zarina Holding CV
By PHILLIPS ORMONDE & FITZPATRICK
Patent Attorneys
By *David Fitzpatrick*

Our Ref : 334080

5999q

M 047080 060793



AU9341753

(12) PATENT ABRIDGMENT (11) Document No. AU-B-41753/93
(19) AUSTRALIAN PATENT OFFICE (10) Acceptance No. 660816

(54) Title
FILTER

International Patent Classification(s)
(51)⁵ **B01D 035/02**

(21) Application No. : **41753/93**

(22) Application Date : **06.07.93**

(30) Priority Data

(31) Number	(32) Date	(33) Country
92/5043	07.07.92	ZA SOUTH AFRICA
92/8987	20.11.92	ZA SOUTH AFRICA

(43) Publication Date : **13.01.94**

(44) Publication Date of Accepted Application : **06.07.95**

(71) Applicant(s)
ZARINA HOLDING CV

(72) Inventor(s)
DAVID SEAGRAVE ATKINS

(74) Attorney or Agent
PHILLIPS ORMONDE & FITZPATRICK , 367 Collins Street, MELBOURNE VIC 3000

(56) Prior Art Documents
GB 1588736
US 3502221
US 4961847

(57) Claim

1. A water filter for induced water flow including a hollow body closed at one end with a removable end cap at the other and housing a filter basket with an open end against the closed end of the body, the end cap having an inlet opening and an outlet opening each providing means for connection into a water flow line, the inlet also providing access passage to a substantial depth within the interior of the filter basket, the outlet providing communication between it and the interior of the body outside the basket and a lip seal between the body and the end cap.

"FILTER"

FIELD OF THE INVENTION

This invention relates to filters and more particularly to a filter for coarse filtering debris from an induced flow of water.

BACKGROUND OF THE INVENTION

5 There are many applications in which circulated water could benefit from the removal of debris from the water prior to it reaching a pump inlet. This

is especially the case where the water is to be passed from the pump through a sand or bag filter to remove small dirt particles from the water.

This situation occurs in swimming pool filter assemblies to a very large extent and it has been proposed to use an in-line filter in the flexible hose which is used with the pool cleaning equipment. Such a filter has a body with axial inlet and outlet openings with means for connecting the body into a flexible hose. The body consists of an end cap and a main part housing a filter basket with a lip seal and bayonet and socket type joint between these body components. The inlet opening extends from the cap and the outlet opening from the main part.

While these filters have proved effective they are difficult to clean in that the hose must be separated into two parts to enable the basket to be removed for cleaning usually enabling air to enter the system.

OBJECT OF THE INVENTION

It is the object of the invention to provide a filter unit which is more versatile and easier to use and clean than that above referred to. A further object is to
5 provide a filter which will reduce blockages in the filter caused by large leaves and similar debris.

SUMMARY OF THE INVENTION

10 According to this invention there is provided a water filter for induced water flow including a hollow body closed at one end with a removable end cap at the other and housing a filter basket with an open end against the closed end of the body, the end cap having an inlet opening and an outlet opening each providing
15 means for connection into a water flow line, the inlet also providing access passage to a substantial depth within the interior of the filter basket, the outlet providing communication between it and the interior of the body outside the basket and a lip seal between the body and the end cap.

20 The invention also provides for a seal around the access passage into the basket and for the end cap to be connected to the body by means of a bayonet or screw type joint.

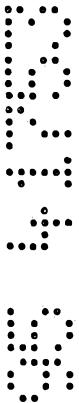

access passage into the basket and for the end cap
to be connected to the body by means of a bayonet
or screw type joint including a peripheral lip seal
or o-ring or compression seal between the end cap
and body.

5

The access into the basket will preferably be
through a curved tubular member in sealing
engagement with the periphery of an aperture into
the basket, at least the downstream surface of the
curved part of the member having a large radius of
curvature and an overload relief spring permitting
movement of the basket relative to the tubular
member can be included in the assembly.

10

Further features of this invention provide for the
body to have a relief valve through the wall
thereof opening into the basket, for a baffle ring
to be included between the basket and body near the
open end and for the tubular member in the end cap
to fit into the wide end of a truncated conical
inlet into the basket.

15

20

The relief valve will preferably comprise an
annular diaphragm located between the wall of a
hollow body and a tubular inlet opening into the



body, the diaphragm secured to the inner wall of the body and having its inner edge in frictional engagement with the inlet, the body having an outlet remote from the diaphragm.

5 A still further feature of this invention provides for the end cap to include a flotation chamber to entrap air.

Still further features of this invention provide for a debris breaking medium to be included in the basket filter which medium is capable of being
10 moved in the basket by the turbulent water flow through the basket.

BRIEF DESCRIPTION OF THE DRAWINGS

These and other features of this invention will become apparent from the following description of one embodiment described below with reference to
15 the accompanying drawings in which

Fig 1 is a cross-sectional view through the filter and

Fig 2 is a part sectional end view of the end cap.

DETAILED DESCRIPTION OF THE DRAWINGS

As illustrated the filter (1) is particularly suitable for use with a swimming pool cleaner and consists of a body (2) closed at one end (3). The other open end of the body provides the socket of a bayonet and socket joint indicated at (4).

The spigot (5) of the bayonet joint includes a peripheral lip seal provided around the open end of the body and the spigot forms part of an end cap (6). The end cap (6) has tubular inlet and outlet openings (7) and (8) integral therewith and separated from each other by a wall (9) which forms part of a tubular member (10) connected to the inlet opening (7). There is thus a flow path through the inlet (7) into the tubular member (10) and out of the end cap (6). It is to be noted that the curved downstream wall of the tubular member (10) has a large radius of curvature. This has been

5

10

15

20

found in use to materially assist in preventing entrained debris blocking this member.

5 The opening (11) around the tubular member (10) into the end cap (6) communicates with the outlet (8).

10 The closed end (3) of the body (4) supports the open end of a perforated filter basket (12). The opposite end of the basket (12) has truncated conical inlet (13) which surrounds the tubular member (10). The end of the member (10) is a close fit within the wide end of the conical inlet (13).

15 An overload relief spring may be retained between between the end cap (6) and the basket (12). This will be arranged to permit axial movement of the basket along the tubular member (10).

20 This arrangement ensures that when flow is induced through the filter it will pass through inlet (7), tubular member (10), through the walls of the basket and out through opening (11) and outlet (8). When flow through the basket becomes too restrained

the basket will lift against the action of the overload spring and create an opening for fluid flow under the edge of the open bottom of the basket. However this refinement will not usually be necessary because the filter is easily cleaned and with normal attention will not become blocked.

5

A relief valve (14) is included in the closed end (3) of the body (2) so that if the flow induced through the filter inlet (7) is greater than that desired to operate the swimming pool cleaner with which it is used then a relief flow can pass through the valve (16). The valve (14) can conveniently be in the form of a body (15) having an inlet (16) in the form of a tube opening into the body (15) and an outlet (17) and an annular flexible diaphragm (18) in frictional resilient engagement around the inlet (16) and having its outer periphery secured to the wall of the body (15). The opening through the diaphragm (18) is such that there is a preloading applied to the diaphragm which ensures that it will only flex inwardly into the body (15) to allow flow between the diaphragm (18) and the inlet (16) when the

10

15

20

pressure within the body (15) has been reduced to a predetermined level.

Any increase in reduction of pressure below the predetermined level will result in increasing the opening between the diaphragm (18) and the tubular inlet (16).

This will control the amount of relief flow through the valve (16).

It will be appreciated the relief valve need not be of this particular type but any suitable valve can be used.

To facilitate the release of the bayonet joint (5) so that the basket (12) can be moved for cleaning handles (19) and (20) are provided on the body (4) and end cap (6) respectively.

The basket (12) has near its open end a peripheral flange (21) which extends from the basket to adjacent the inner wall of the body. It has been found that this flange (21) acts as a baffle and

sand entrained in the flow through the filter gravitates to the lower region and the baffle restrains the sand in the filter body. The conical inlet to the basket has also been found to assist
5 in providing a flow resulting in the deposit of sand in the bottom of the body.

A flotation chamber (22) in the end cap (6) which can be seen most clearly in Fig 2 entraps air and this will prevent the filter from sinking down into
10 the swimming pool and retain the hose adjacent the surface of the pool in the vicinity of the filter.

A debris breaking medium (23) is located in the filter basket. This medium can be of ball-like shape with a rough surface. The roughness may be
15 provided by protrusions (24) on the surface. The mass of the medium is such that it will be caused to move by water flowing through the filter basket.

The introduction of a breaking medium into the basket has been found to render the filter far more
20 effective in a situation where large numbers of leaves are sucked towards the filter pump. The flow

induced through the filter results in turbulence within the basket. This causes the medium to move about the basket and crush leaves between it and the wall of the basket.

5 It has been found that by suitable choice of the density of the crushing medium the filter can be made to trap up to four times more debris than the filter without this medium before cleaning is required. This is because leaves are prevented from
10 lying against the wall of the basket and thereby blocking large areas of filter surface. They are broken up into small pieces allowing adequate flow through the filter for a far longer period than is otherwise possible without cleaning.

15 It will be understood that the crushing medium can be widely varied without departing from the scope of this invention. It may be a single ball or a plurality of balls. The main criterion is that the medium be such that it will move sufficiently under
20 the turbulence generated in the basket to cause breaking of the debris between the medium and wall of the basket.

The filter (1) as stated above is particularly suitable for inclusion in the induced flow line of a domestic swimming pool cleaner. The filter can be included in the flexible hose where it will be understood that the hose need not be broken when the filter basket (12) has to be removed for cleaning. The body (2) is disconnected from the end cap (6) and the filter basket (12) and body (2) cleaned and replaced without interference with the relief valve (14) or the connections between the flexible hose and end cap (6).

Alternatively the filter may be included in the weir assembly of the swimming pool between the weir inlet and the connection to the pump. A second water path to the pump can easily be provided from the bottom of the weir to provide for surface flow from the pool to the pump and effect the desired skimming of the pool surface.

Wherever the filter is located it will be understood that the body and basket are located below the direct flow line to the pump. This has been found to enable the filter to operate

effectively to remove debris from the water. Also smaller particles tend to sink as a sediment into the bottom of the body.

5

The filter is effective, easily cleaned and maintained and the inclusion of the relief valve has been found to avoid the necessity for a separate device for this purpose in the flow line from the pool cleaner to the pump. This is particularly so when the filter is located in the pool weir.

10

15

Also it will be appreciated that the filter can be supported in a floating bucket in a manner which will enable the relief valve to operate as a moving and floating weir to skim the surface of the water in which the filter is located.

The claims defining the invention are as follows:

1. A water filter for induced water flow including a hollow body closed at one end with a removable end cap at the other and housing a filter basket with an open end against the closed end of the body, the end cap having an inlet opening and an outlet opening each providing means for connection into a water flow line, the inlet also providing access passage to a substantial depth within the interior of the filter basket, the outlet providing communication between it and the interior of the body outside the basket and a lip seal between the body and the end cap.
2. A filter as claimed in claim 1 wherein the access passage into the interior of the basket is provided in part by a truncated conical inlet to the basket which engages the end of the access passage from the end cap.
3. A filter as claimed in claim 1 or 2 in which the end cap and body are connected by means of a bayonet and socket joint.
4. A filter as claimed in any one of the preceding claims in which the open end of the basket is resiliently biased against the closed end of the body.



5. A filter as claimed in any one of the preceding claims in which a relief valve is provided opening into the body.

5 6. A filter as claimed in claim 5 in which the relief valve opens into the body within the open end of the basket.

7. A filter as claimed in claim 6 in which the relief valve ^{includes} ~~comprises~~ a body having an inlet in the form of a tube opening into the body and an outlet and an annular flexible diaphragm in flexible resilient engagement around the inlet with its outer periphery secured to the wall of the body.

10

8. A filter as claimed in any one of the preceding claims in which a flotation chamber is provided in the end cap.

15

9. A filter as claimed in any one of the preceding claims in which the filter basket has an external flange near its open end to form a baffle between the basket and the body.

20

10. A filter as claimed in any one of the preceding claims in which a debris breaking medium is located within the basket.

11. A filter substantially as described and
5 illustrated in the accompanying drawings.

DATED: 5 July, 1993

PHILLIPS ORMONDE & FITZPATRICK

Attorneys for:

ZARINA HOLDING CV

David B Fitzpatrick

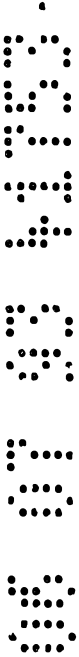

ABSTRACT

This invention concerns a water filter particularly suitable for use in coarse filtering the induced water flow from a swimming pool. The filter has a body closed at one end the other connected by means of a bayonet and socket joint to an end cap with a lip seal between the end cap and body. There is provided a filter basket in the body with an open end held against the closed end of the body and the end cap providing an inlet into the basket and an outlet from outside the basket. The inlet and outlet providing means for connection into a water flow line. A relief valve through the wall of the body opening into the basket may also be provided.

5

10

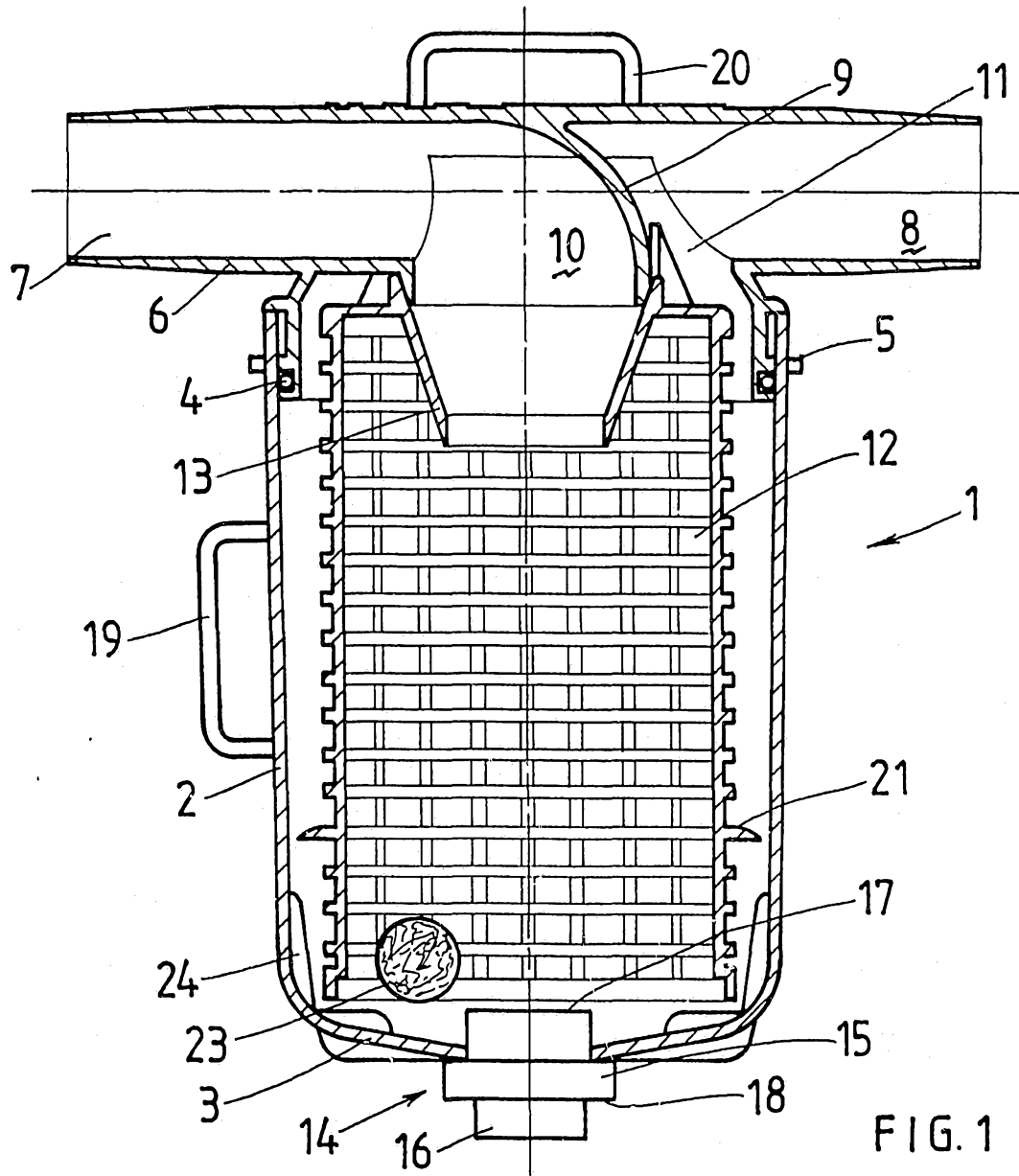

FIG. 1

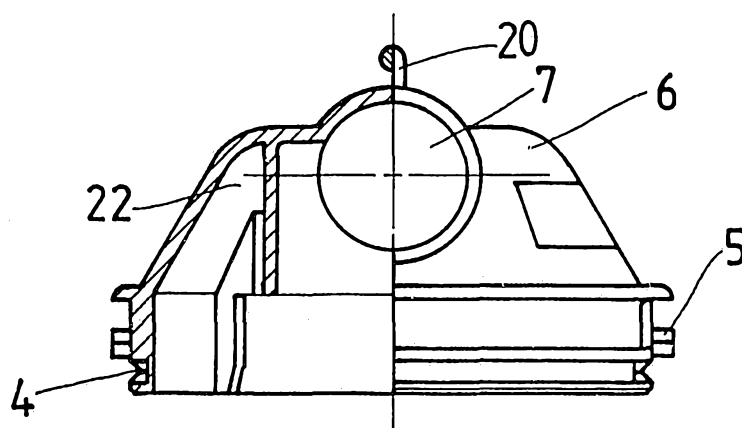

FIG. 2

20
4
2
19
13
12
11
10
9
8
7
6
5
4
3
2
1
18
17
16
15
14