



(51) International Patent Classification:
A61M 5/32 (2006.01) A61M 5/31 (2006.01)

(21) International Application Number:
PCT/CA2011/000210

(22) International Filing Date:
28 February 2011 (28.02.2011)

(25) Filing Language: English

(26) Publication Language: English

(30) Priority Data:
2,695,265 2 March 2010 (02.03.2010) CA

(71) Applicant (for all designated States except US): **DUOJECT MEDICAL SYSTEMS INC.** [CA/CA]; 50, rue De Gaspe, Complex B-5, Bromont, Quebec J2L 2N8 (CA).

(72) Inventors; and

(75) Inventors/Applicants (for US only): **REYNOLDS, David, L.** [CA/CA]; 50, rue De Gaspe, Complex B-5, Bromont, Quebec J2L 2N8 (CA). **MACDONALD, Daniel** [CA/CA]; 202-5, rue Des Deux-Montagnes, Bromont, Quebec J2L 1P3 (CA). **TREMBLAY, Yan** [CA/CA]; 165, rue de l'Erabliere, Orford, Quebec J1X 6J8 (CA). **TREPANIER, Julie** [CA/CA]; 1071, Falaise Street, Sherbrooke, Quebec J1N 2M9 (CA).

(74) Agent: **FINCHAM, Eric**; 1991 Perigny Blvd., Suite 104, Chambly, Québec J3L 4C3 (CA).

(81) Designated States (unless otherwise indicated, for every kind of national protection available): AE, AG, AL, AM, AO, AT, AU, AZ, BA, BB, BG, BH, BR, BW, BY, BZ, CA, CH, CL, CN, CO, CR, CU, CZ, DE, DK, DM, DO, DZ, EC, EE, EG, ES, FI, GB, GD, GE, GH, GM, GT, HN, HR, HU, ID, IL, IN, IS, JP, KE, KG, KM, KN, KP, KR, KZ, LA, LC, LK, LR, LS, LT, LU, LY, MA, MD, ME, MG, MK, MN, MW, MX, MY, MZ, NA, NG, NI, NO, NZ, OM, PE, PG, PH, PL, PT, RO, RS, RU, SC, SD, SE, SG, SK, SL, SM, ST, SV, SY, TH, TJ, TM, TN, TR, TT, TZ, UA, UG, US, UZ, VC, VN, ZA, ZM, ZW.

(84) Designated States (unless otherwise indicated, for every kind of regional protection available): ARIPO (BW, GH, GM, KE, LR, LS, MW, MZ, NA, SD, SL, SZ, TZ, UG, ZM, ZW), Eurasian (AM, AZ, BY, KG, KZ, MD, RU, TJ, TM), European (AL, AT, BE, BG, CH, CY, CZ, DE, DK, EE, ES, FI, FR, GB, GR, HR, HU, IE, IS, IT, LT, LU, LV, MC, MK, MT, NL, NO, PL, PT, RO, RS, SE, SI, SK, SM, TR), OAPI (BF, BJ, CF, CG, CI, CM, GA, GN, GQ, GW, ML, MR, NE, SN, TD, TG).

Published:

— with international search report (Art. 21(3))

(54) Title: INJECTION DEVICE

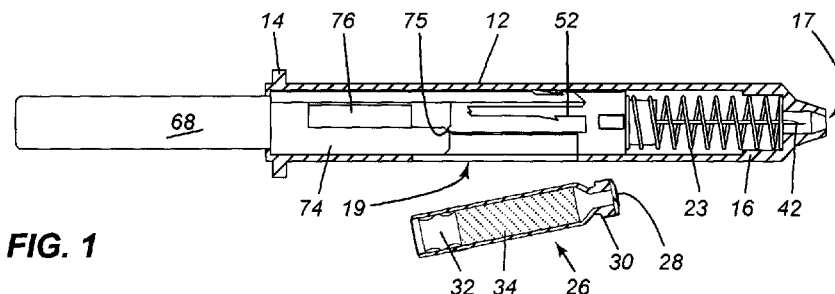

FIG. 1

(57) Abstract: An injection device (10) comprising a housing (12), a needle hub (38) slidable within the housing (12), a needle (40) having a distal end piercing tip (42) and a proximal end piercing tip (44), the needle hub being moveable from a first position wherein the distal end piercing tip (42) is within the housing to a second position wherein the distal end piercing tip (42) extends outwardly of the housing (12), a spring (23) biasing the needle hub (38) towards the first position, and a cartridge receiving member (48) mounted within the housing (12), and a plunger rod assembly (66) for exerting pressure on the cartridge receiving member (48) to move the cartridge (26) and the needle hub (38) from the first position to the second position, the plunger rod assembly (66) and the cartridge receiving member (48) being arranged such that when the cartridge rod assembly is pushed, a rotational movement is imparted to the cartridge receiving member (48) to thereby prevent access to the cartridge after injection.



- 1 -

INJECTION DEVICE

FIELD OF THE INVENTION

The present invention relates to a medical device and more particularly, relates to an injection device.

BACKGROUND OF THE INVENTION

Injection devices are utilized for administering a drug. There are many known injection devices, the most common of which is a syringe. Known syringes basically comprise a cylindrical tube having a needle mounted at the injection end thereof and a plunger mounted at the other end. Intermediate the needle and the plunger is the constituent to be injected.

Syringes frequently are pre-filled and while this is satisfactory for many medicaments, it is less desirable for other medicaments which must be maintained at a certain temperature. This temperature base usually requires refrigeration of the pre-filled syringe for storage purposes. As will be appreciated, a great deal of space is required for the storage of traditional syringes.

A further problem with traditional syringes is the protection of the person doing the injection. Frequently the medicament being injected can pose a risk for the medical personnel using the syringe. This problem is well known and many different devices or arrangements have been proposed in order to provide protection for the person doing the injection.

SUMMARY OF THE INVENTION

It is an object of the present invention to provide an injection device which provides protection from accidental pricking of the person doing the injection.

- 2 -

It is a further object of the present invention to provide an injection device which does not need to be refrigerated and which can accept a vial of a medicament and safely inject the same into the patient.

According to one aspect of the present invention, there is provided an injection device comprising a housing, an aperture in a side wall of the housing, a needle hub, a needle mounted in the needle hub, the needle having a distal end piercing tip and a proximal end piercing tip, the needle hub being slidably mounted within the housing, the needle hub being movable from a first position wherein the distal end piercing tip is within the housing to a second position wherein the distal end piercing tip extends outwardly of the housing, a spring biasing the needle hub towards the first position, a cartridge receiving member mounted within the housing, the cartridge receiving member being accessible through the aperture in the side wall of the housing, and a plunger rod assembly for exerting pressure on the cartridge receiving member to move the cartridge and the needle hub from the first position to the second position, the plunger rod assembly and the cartridge receiving member having cooperating means such that when the plunger rod assembly is pushed to cause the cartridge plunger to be pierced by the proximal end piercing tip, a rotational movement is imparted to the cartridge receiving member to thereby prevent access to the cartridge through the aperture in the side wall of the housing.

The injection device of the present invention will typically be utilized for administering a drug to a patient by qualified medical personnel. However, it will be understood that the scope of the invention is not limited to such an arrangement. In some instances, the patient may self-inject utilizing the device of the present invention. Furthermore, the device can be utilized with any animal requiring injection of the medicament.

- 3 -

As used herein, the distal end refers to the end through which the injection is made while the proximal end is the end closer to the hand of the person administering the injection.

The injection device may be formed of any suitable material, including glass, plastics, metallic material, combinations thereof, et cetera. It suffices to say that those knowledgeable in the art will select the materials most suitable for the manufacture of the device.

The housing functions to contain the various components of the invention and conveniently may be formed of a molded plastic or the like. The housing will also interact with the other components to assist in the motions as will be described in greater detail hereinbelow.

The needle hub is arranged to receive a needle having a distal end piercing tip and a proximal end piercing tip. The distal end piercing tip will be a typical injection piercing tip and is of a relatively small diameter as is known in the art.

The cartridge receiving member, in a preferred embodiment, is formed integrally with the needle hub and naturally is movable therewith.

The cartridge receiving member is further characterized by having a partial wall which will extend partially around the cartridge. The remainder is open to receive the cartridge through an aperture in the housing. However, upon movement of the plunger rod upwardly, the cartridge receiving member is caused to rotate such that the aperture in the housing is covered by the cartridge receiving member partial wall. Furthermore, when in the position wherein access may not be provided to the cartridge, the cartridge receiving member cannot be rotated back to its original position.

BRIEF DESCRIPTION OF THE DRAWINGS

Having thus generally described the invention, reference will be made to the accompanying drawings illustrating an embodiment thereof, in which:

- 4 -

Figure 1 is a side sectional view illustrating the device and a cartridge;

Figure 2 is a side sectional view illustrating placement of the cartridge in the device;

Figure 3 is a side sectional view illustrating the cartridge in the device with piercing of the septum;

Figure 4 is a side sectional view illustrating initial movement of the cartridge within the holder;

Figure 5 is a side sectional view illustrating further movement of the cartridge and needle hub;

Figure 6 is a side sectional view illustrating further movement of a plunger rod;

Figures 7 and 8 are side sectional views illustrating progression of the movement and injection of the cartridge contents;

Figure 9 is a side sectional view illustrating rearward movement of the needle hub, cartridge and cartridge holder;

Figure 10 is a side sectional view illustrating the device after injection and withdrawal of the needle;

Figure 11 is a side sectional view of the housing;

Figure 12 is a perspective view of the needle hub and cartridge holder;

Figure 13 is a further perspective view of the needle hub and cartridge holder;

Figure 14 is a perspective view of the plunger rod assembly;

Figure 15 is a perspective view illustrating the initial engagement of the plunger rod and needle hub; and

Figure 16 is a perspective view showing the position of the needle hub and plunger rod after injection.

- 5 -

DETAILED DESCRIPTION OF THE INVENTION

Referring to the drawings and by reference characters thereto, there is illustrated in Figures 1 to 10 the device of the present invention (generally designated by reference numeral 10) along with a cartridge generally designated by reference numeral 26.

Device 10 has an outer generally cylindrically shaped housing 12. A flange 14 is provided at the proximal end of housing 12 while at the distal end of housing 12 there is provided a cap 16. Cap 16 is screwthreadedly engaged with the distal end of housing 12. It will be noted that there is an aperture or opening 17 in cap 16 to provide for a needle passing therethrough. A slot 15 formed in an area adjacent flange 14 for reasons discussed hereinbelow.

As may be seen in Figure 11, there is a longitudinally extending rib 18 formed on the inner surface of housing 12. While rib 18 is shown extending a substantial length of the housing 12, it is only the upper or distal portion which is required in many embodiments. Rib 18 is provided with a recess generally designated by reference numeral 20. Rib 18 also has an angled top wall 22. An opening 19 is provided in housing 12 to permit the insertion of a cartridge as seen in Figures 1 to 10.

Cartridge 26 may be a standard cartridge or vial and will contain the medicament to be injected into the patient. Cartridge 26, as is conventional in the art, has a septum 28 and a cap 30 covering septum 28. A plunger 32 is mounted interiorly of the cartridge at the proximal end thereof to prevent loss of medicament 34.

A moveable needle hub 38 is mounted within housing 12 and there is provided a needle 40. Needle 40 includes a distal end piercing tip 42 for injection into the patient and a proximal piercing tip 44 which is arranged to pierce septum 28 of cartridge 26 to provide

- 6 -

access to medicament 34.

Needle hub 38 has an upper cylindrical portion 46 and a cartridge receiving member defined by a lower semi-cylindrical wall 48 depending downwardly therefrom. On the exterior of semi-cylindrical wall 48, there is formed a recess 50 which extends partially into wall 48. A raised land portion 52 is located within recess 50 to define a first channel 54 and a second channel 56. A recess 61 is formed in second channel 56 by protrusion 63. At the lower end of raised land portion 52, there is provided a first angled bottom wall 58 which meets a side wall 60 so as to form a small notch. On the opposite side, there is provided a second angled bottom wall 62. A further angled wall section 59 is provided on needle hub 38 proximate an upper portion thereof.

A plunger rod assembly generally designated by reference numeral 66 has a lower cylindrical portion 68 at the top of which there is formed an enlarged portion 70 having a slot 72 formed therein for reasons which will be discussed hereinbelow. A rib 65 is formed on the exterior of lower cylindrical portion 68 for engagement with slot 15.

Plunger rod 66 also includes an upper partial wall 74 which extends about a central pushing rod 76 which is sized to fit within vial 26 to push plunger 32. At an upper corner of upper partial wall 74, there is provided a recess 75 having a hook configuration.

Vial 26 is inserted through opening 19 in housing 12 as may be seen in Figures 1 and 2. If desired, it can be arranged such that vial 26 has septum 28 pierced by lower piercing end 44 upon insertion. A spring 23 extends about the upper portion of needle 40.

Initially, recess portion 75 engages end wall 62 which is tapered. The hooked nature of recess 75 ensures that the two walls remain in contact for a period of time sufficient for piercing end 44 to pierce septum 28. Continued pressure on plunger rod 66 will cause

- 7 -

corners 75 and 71 to disengage and impart a rotational movement to needle hub 38. In turn, this will allow rib 18 to enter first channel 54. Continued pressure on plunger rod 66 will cause corner 75 to contact slanted wall 59. This causes a further rotation of needle hub 38 with respect to housing 12. This further rotation will cause the upper end of rib 18 to enter into channel 56. In so doing, pressure will be exerted until the top of rib 18 enters recess 61. The rib is then in a locked position and needle hub 38 is pushed rearwardly by spring 23. The continued engagement of the top of rib 18 within recess 61 assures that the needle cannot be exposed as it is locked in place.

- 8 -

WE CLAIM:

1. An injection device comprising:

a housing (12), an aperture (19) in a side wall of said housing;

a needle hub (38), a needle (40) mounted in said needle hub (38), said needle (40)

having a distal end piercing tip (42) and a proximal end piercing tip (44); said needle

hub (38) being slidably mounted within said housing (12), said needle hub (38) being

movable from a first position wherein said distal end piercing tip (42) is within said

housing (12) to a second position wherein said distal end piercing tip (42) extends outwardly

of said housing (12);

a spring (23) biasing said needle hub (38) towards said first position;

a cartridge receiving member (48) mounted within said housing, said cartridge receiving member (48) being accessible through said aperture (19) in said side wall of said housing (12); and

a plunger rod assembly (66) for exerting pressure on said cartridge receiving member (48) to move said cartridge (26) and said needle hub (38) from said first position to said second position, said plunger rod assembly (66) and said cartridge receiving member (48) having cooperating means such that when said plunger rod assembly is pushed to cause the cartridge plunger to be pierced by said proximal end piercing tip, a rotational movement is imparted to said cartridge receiving member (66) to thereby prevent access to said cartridge through said aperture in said side wall of said housing.

2. The injection device of Claim 1 wherein said cartridge receiving member (48) and said needle hub (38) are integral.

- 9 -

3. The injection device of Claim 2 wherein said plunger rod assembly (66) has a pusher rod (76) and an upper partial wall (74) partially surrounding said pusher wall, said upper partial wall (74) having a length greater than said pusher rod (76).
4. The injection device of Claim 3 wherein said upper partial wall (74) has an angled corner (75), said cartridge receiving member (48) having a cartridge receiving member partial wall, said cartridge receiving member partial wall having a tapered corner (62) to engage with said angled corner (75) on said upper partial wall (74) to permit pushing of said cartridge receiving member (48) upwardly.
5. The injection device of Claim 4 wherein contact of said upper partial wall (74) and said cartridge receiving member partial wall causes said cartridge receiving member (48) to rotate and thereby cause said cartridge receiving member partial wall to block said opening in said housing to thereby prevent removal of said cartridge therefrom.
6. The injection device of Claim 5 wherein said housing has a protrusion on an inner surface thereof, said cartridge receiving member having first and second channels, said second channel having a recess formed therein to engage said protrusion on said inner surface of said housing to prevent further movement of said cartridge receiving member.

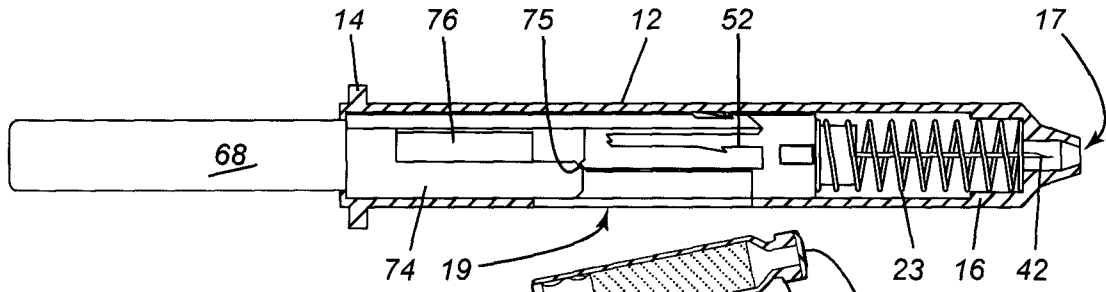

FIG. 1

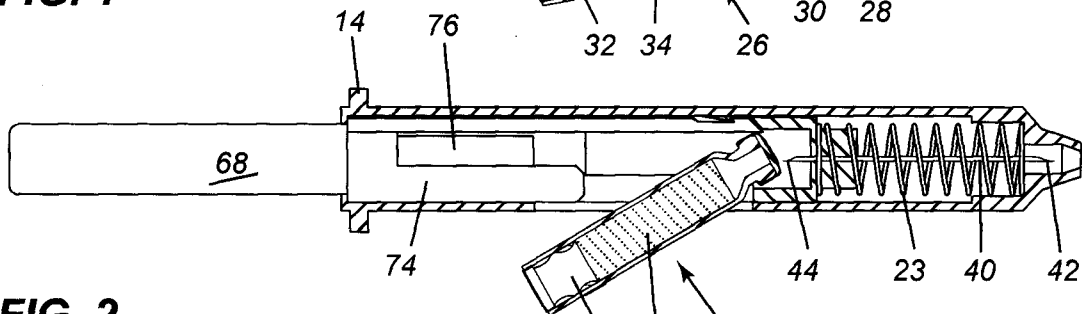

FIG. 2

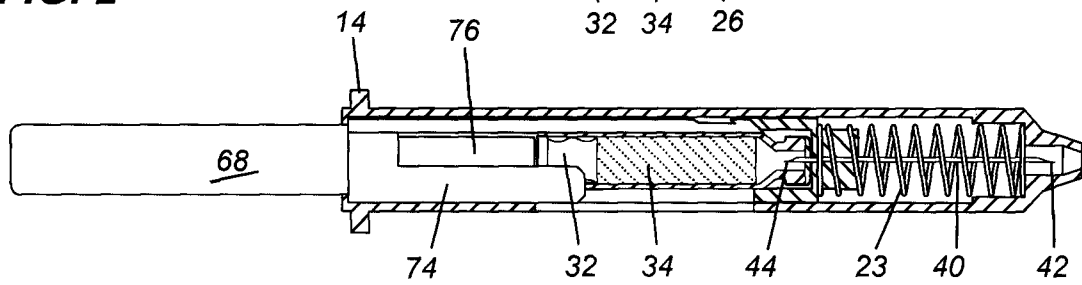

FIG. 3

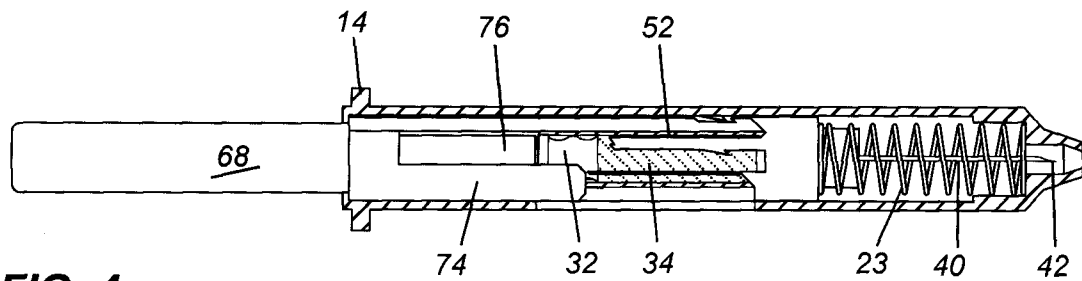

FIG. 4

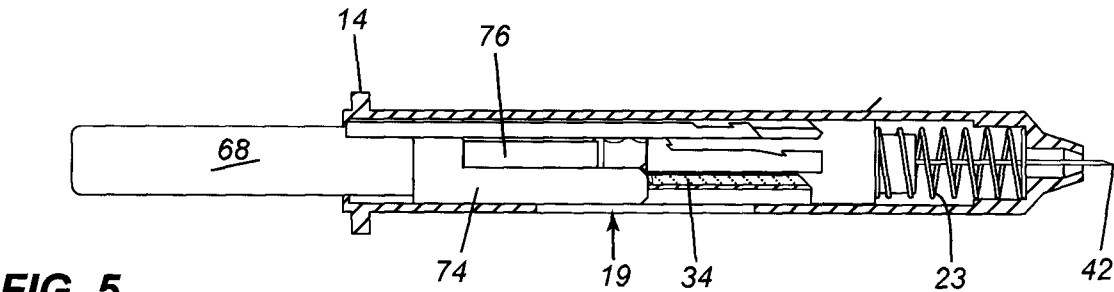

FIG. 5

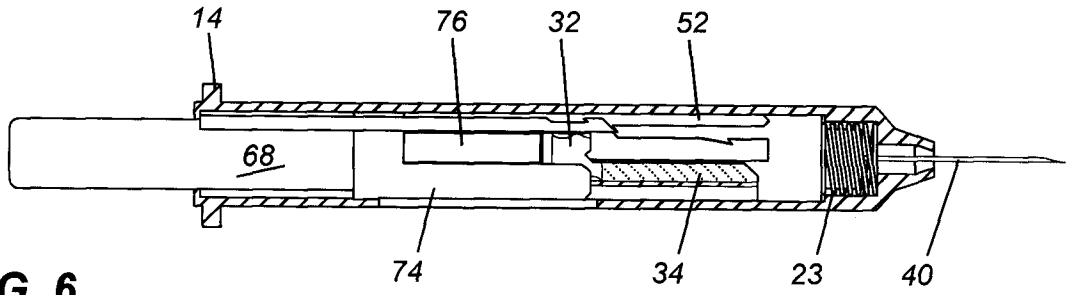

FIG. 6

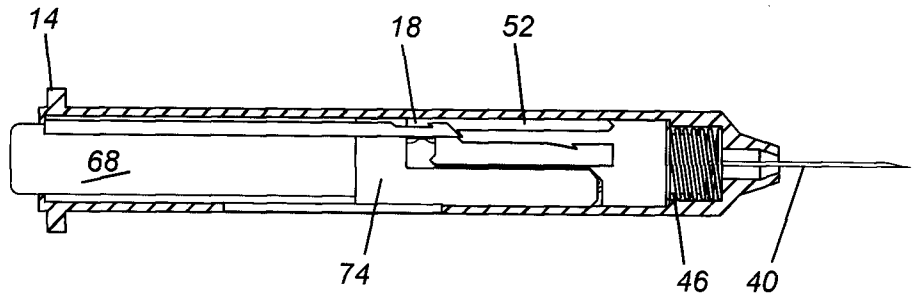

FIG. 7

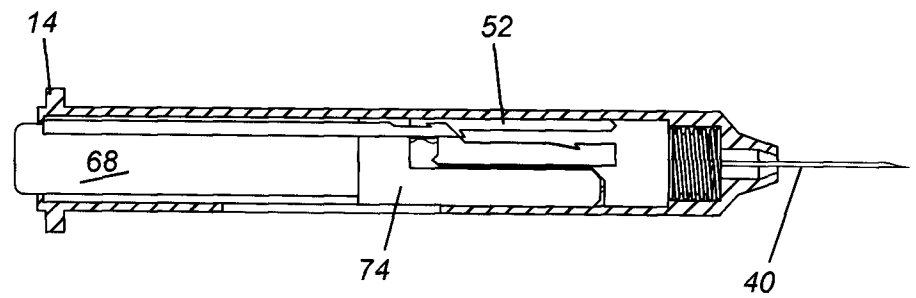

FIG. 8

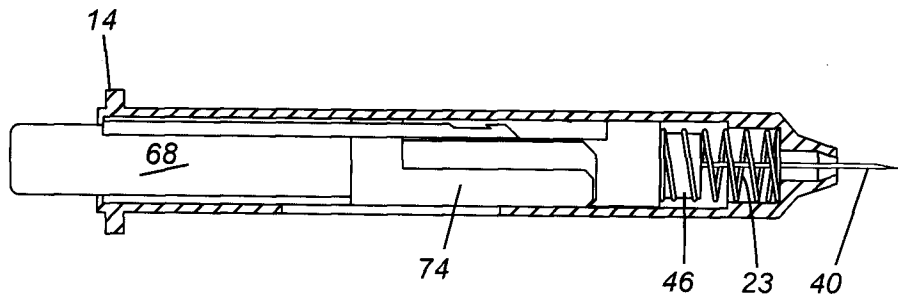

FIG. 9

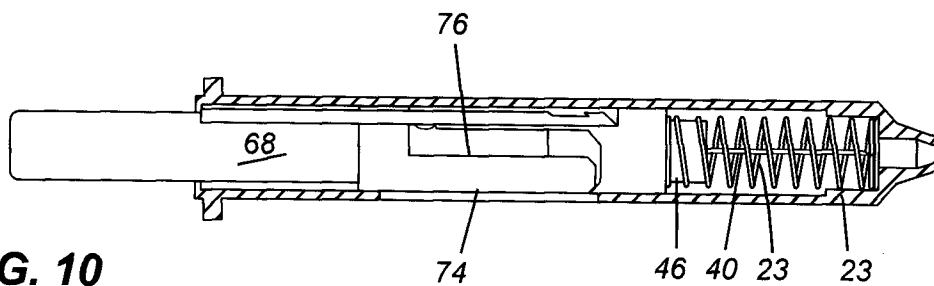

FIG. 10

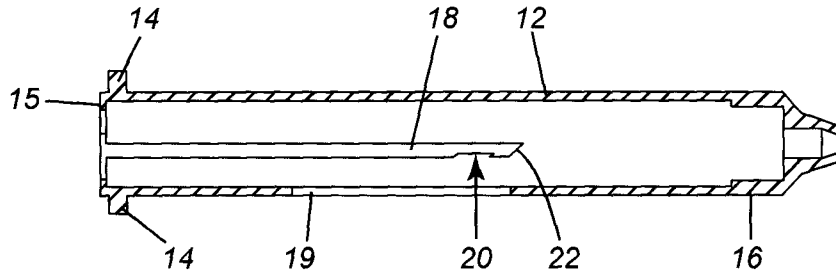

FIG. 11

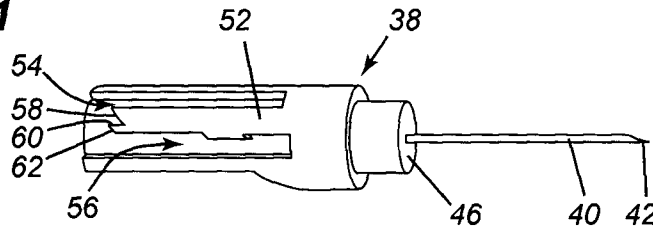

FIG. 12

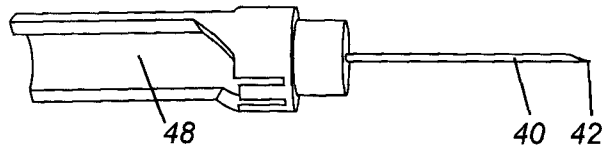

FIG. 13

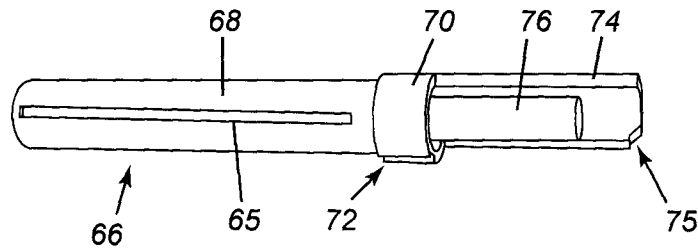

FIG. 14

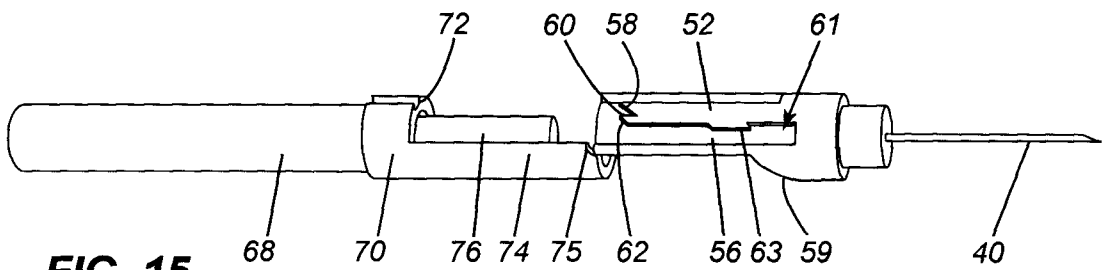

FIG. 15

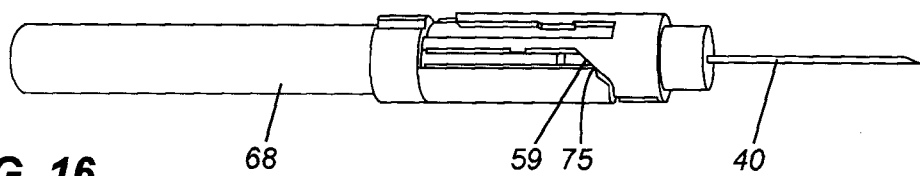

FIG. 16

INTERNATIONAL SEARCH REPORT

International application No.
PCT/CA2011/000210

<p>A. CLASSIFICATION OF SUBJECT MATTER IPC: A61M 5/32 (2006.01) , A61M 5/31 (2006.01) According to International Patent Classification (IPC) or to both national classification and IPC</p>				
<p>B. FIELDS SEARCHED</p>				
<p>Minimum documentation searched (classification system followed by classification symbols) IPC: A61M 5/32, A61M 5/31</p>				
<p>Documentation searched other than minimum documentation to the extent that such documents are included in the fields searched</p>				
<p>Electronic database(s) consulted during the international search (name of database(s) and, where practicable, search terms used) EPOQUE (Epodoc) and CPD Keywords: cartridge, vial, septum, medicament, aperture, opening, housing, piercing, rotation(al), prevent, access, lock, safety, protection, rib, recess, engage</p>				
<p>C. DOCUMENTS CONSIDERED TO BE RELEVANT</p>				
Category*	Citation of document, with indication, where appropriate, of the relevant passages	Relevant to claim No.		
A	CA 2618587 A1 (Becton, Dickinson and Company) 23 July 2008 (23-07-2008)	1-6		
A	CA 2106577 A1 (Habley Medical Technology Co.) 9 October 1992 (9-10-1992)	1-6		
A	US 2003/0106824 A1 (Meridian Medical Technologies, Inc.) 12 June 2003 (12-06-2003)	1-6		
A	WO 01/60436 A1 (Comar Inc.) 23 August 2001 (23-08-2001)	1-6		
<p><input type="checkbox"/> Further documents are listed in the continuation of Box C. <input checked="" type="checkbox"/> See patent family annex.</p>				
<table style="width:100%; border:none;"> <tr> <td style="width:50%; border:none;"> <p>* Special categories of cited documents :</p> <p>"A" document defining the general state of the art which is not considered to be of particular relevance</p> <p>"E" earlier application or patent but published on or after the international filing date</p> <p>"L" document which may throw doubts on priority claim(s) or which is cited to establish the publication date of another citation or other special reason (as specified)</p> <p>"O" document referring to an oral disclosure, use, exhibition or other means</p> <p>"P" document published prior to the international filing date but later than the priority date claimed</p> </td> <td style="width:50%; border:none;"> <p>"T" later document published after the international filing date or priority date and not in conflict with the application but cited to understand the principle or theory underlying the invention</p> <p>"X" document of particular relevance; the claimed invention cannot be considered novel or cannot be considered to involve an inventive step when the document is taken alone</p> <p>"Y" document of particular relevance; the claimed invention cannot be considered to involve an inventive step when the document is combined with one or more other such documents, such combination being obvious to a person skilled in the art</p> <p>"&" document member of the same patent family</p> </td> </tr> </table>			<p>* Special categories of cited documents :</p> <p>"A" document defining the general state of the art which is not considered to be of particular relevance</p> <p>"E" earlier application or patent but published on or after the international filing date</p> <p>"L" document which may throw doubts on priority claim(s) or which is cited to establish the publication date of another citation or other special reason (as specified)</p> <p>"O" document referring to an oral disclosure, use, exhibition or other means</p> <p>"P" document published prior to the international filing date but later than the priority date claimed</p>	<p>"T" later document published after the international filing date or priority date and not in conflict with the application but cited to understand the principle or theory underlying the invention</p> <p>"X" document of particular relevance; the claimed invention cannot be considered novel or cannot be considered to involve an inventive step when the document is taken alone</p> <p>"Y" document of particular relevance; the claimed invention cannot be considered to involve an inventive step when the document is combined with one or more other such documents, such combination being obvious to a person skilled in the art</p> <p>"&" document member of the same patent family</p>
<p>* Special categories of cited documents :</p> <p>"A" document defining the general state of the art which is not considered to be of particular relevance</p> <p>"E" earlier application or patent but published on or after the international filing date</p> <p>"L" document which may throw doubts on priority claim(s) or which is cited to establish the publication date of another citation or other special reason (as specified)</p> <p>"O" document referring to an oral disclosure, use, exhibition or other means</p> <p>"P" document published prior to the international filing date but later than the priority date claimed</p>	<p>"T" later document published after the international filing date or priority date and not in conflict with the application but cited to understand the principle or theory underlying the invention</p> <p>"X" document of particular relevance; the claimed invention cannot be considered novel or cannot be considered to involve an inventive step when the document is taken alone</p> <p>"Y" document of particular relevance; the claimed invention cannot be considered to involve an inventive step when the document is combined with one or more other such documents, such combination being obvious to a person skilled in the art</p> <p>"&" document member of the same patent family</p>			
<p>Date of the actual completion of the international search 11 May 2011 (11-05-2011)</p>		<p>Date of mailing of the international search report 6 June 2011 (06-06-2011)</p>		
<p>Name and mailing address of the ISA/CA Canadian Intellectual Property Office Place du Portage I, C114 - 1st Floor, Box PCT 50 Victoria Street Gatineau, Quebec K1A 0C9 Facsimile No.: 001-819-953-2476</p>		<p>Authorized officer Alexis Cote (819) 934-8532</p>		

INTERNATIONAL SEARCH REPORT
Information on patent family members

International application No.
PCT/CA2011/000210

Patent Document Cited in Search Report	Publication Date	Patent Family Member(s)	Publication Date
CA2618587A1	23 July 2008 (23-07-2008)	CA2618587A1 EP1949927A1 JP2008229321A US7384414B1	23 July 2008 (23-07-2008) 30 July 2008 (30-07-2008) 02 October 2008 (02-10-2008) 10 June 2008 (10-06-2008)
CA2106577A1	09 October 1992 (09-10-1992)	AU1741992A EP0579735A1 EP0579735A4 JP7507215T US5263942A WO9217230A1	02 November 1992 (02-11-1992) 26 January 1994 (26-01-1994) 19 October 1994 (19-10-1994) 10 August 1995 (10-08-1995) 23 November 1993 (23-11-1993) 15 October 1992 (15-10-1992)
US2003106824A1	12 June 2003 (12-06-2003)	AU2002348148B2 AU2008200344A1 CA2465436A1 CN1607968A EP1455864A2 IL161682D0 JP2005508231T KR20050042210A MXPA04004162A US7708719B2 US2010174268A1 WO03039632A2 WO03039632A3	10 July 2008 (10-07-2008) 14 February 2008 (14-02-2008) 15 May 2003 (15-05-2003) 20 April 2005 (20-04-2005) 15 September 2004 (15-09-2004) 27 September 2004 (27-09-2004) 31 March 2005 (31-03-2005) 06 May 2005 (06-05-2005) 25 January 2005 (25-01-2005) 04 May 2010 (04-05-2010) 08 July 2010 (08-07-2010) 15 May 2003 (15-05-2003) 20 November 2003 (20-11-2003)
WO0160436A1	23 August 2001 (23-08-2001)	AU3816901A DE10195606T0 US2003055395A1 US6706031B2	27 August 2001 (27-08-2001) 30 January 2003 (30-01-2003) 20 March 2003 (20-03-2003) 16 March 2004 (16-03-2004)