



US00D500274S

(12) **United States Design Patent**
Pfeiffer

(10) **Patent No.:** **US D500,274 S**

(45) **Date of Patent:** **** Dec. 28, 2004**

(54) **SURFACE CONFIGURATION OF A SIDE MIRROR FOR A VEHICLE**

(75) Inventor: **Peter Pfeiffer**, Boeblingen (DE)
(73) Assignee: **DaimlerChrysler AG**, Stuttgart (DE)
(**) Term: **14 Years**

(21) Appl. No.: **29/204,532**

(22) Filed: **Apr. 30, 2004**

(30) **Foreign Application Priority Data**

Nov. 3, 2003 (DE) 4 03 06 969

(51) **LOC (7) Cl.** **12-16**

(52) **U.S. Cl.** **D12/187**

(58) **Field of Search** D12/187-189;
359/838-851, 855-868, 871-881

(56) **References Cited**

U.S. PATENT DOCUMENTS

D307,570 S	*	5/1990	Swanson	D12/187
D410,421 S	*	6/1999	Pfeiffer	D12/187
D445,386 S	*	7/2001	Sacco et al.	D12/187
D453,721 S	*	2/2002	Papke et al.	D12/187
D463,342 S	*	9/2002	Sinkwitz	D12/187
D463,766 S	*	10/2002	Murkett	D12/187
6,592,255 B1	*	7/2003	Duroux et al.	374/162
D484,837 S	*	1/2004	Liu	D12/187
D485,521 S	*	1/2004	Kuo	D12/187

* cited by examiner

Primary Examiner—Melody N. Brown

(74) *Attorney, Agent, or Firm*—Crowell & Moring LLP

(57) **CLAIM**

The ornamental design for a surface configuration of a side mirror for a vehicle, as shown and described.

DESCRIPTION

FIG. 1 is a front perspective view of a first embodiment of a surface configuration of a side mirror for a vehicle according to my novel design;

FIG. 2 is a rear perspective view of the first embodiment of the surface configuration of a side mirror for a vehicle according to my novel design;

FIG. 3 is a rear view of the first embodiment of the surface configuration of a side mirror for a vehicle according to my novel design;

FIG. 4 is a top view of the first embodiment of the surface configuration of a side mirror for a vehicle according to my novel design;

FIG. 5 is a side view of the first embodiment of the surface configuration of a side mirror for a vehicle according to my novel design;

FIG. 6 is a bottom view of the first embodiment of the surface configuration of a side mirror for a vehicle according to my novel design;

FIG. 7 is a front view of the first embodiment of the surface configuration of a side mirror for a vehicle according to my novel design;

FIG. 8 is a front perspective view of a second embodiment of the surface configuration of a side mirror for a vehicle according to my novel design;

FIG. 9 is a rear perspective view of the second embodiment of the surface configuration of a side mirror for a vehicle according to my novel design;

FIG. 10 is a rear view of the second embodiment of the surface configuration of a side mirror for a vehicle according to my novel design;

FIG. 11 is a top view of the second embodiment of the surface configuration of a side mirror for a vehicle according to my novel design;

FIG. 12 is a side view of the second embodiment of the surface configuration of a side mirror for a vehicle according to my novel design;

FIG. 13 is a bottom view of the second embodiment of the surface configuration of a side mirror for a vehicle according to my novel design; and,

FIG. 14 is a front view of the second embodiment of the surface configuration of a side mirror for a vehicle according to my novel design.

The broken lines are for illustrative purposes only and form no part of the claimed design.

1 Claim, 8 Drawing Sheets

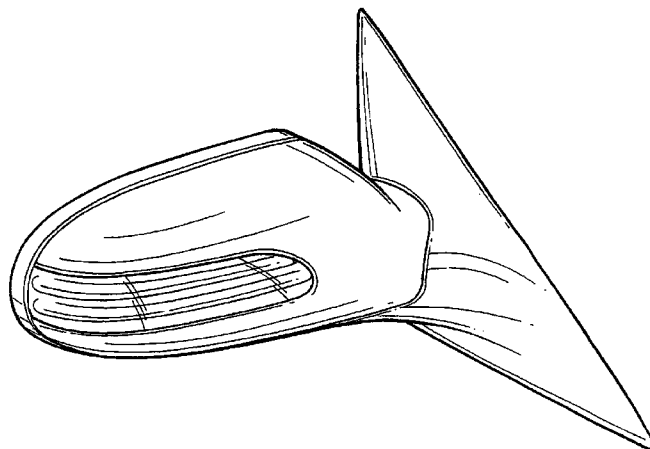

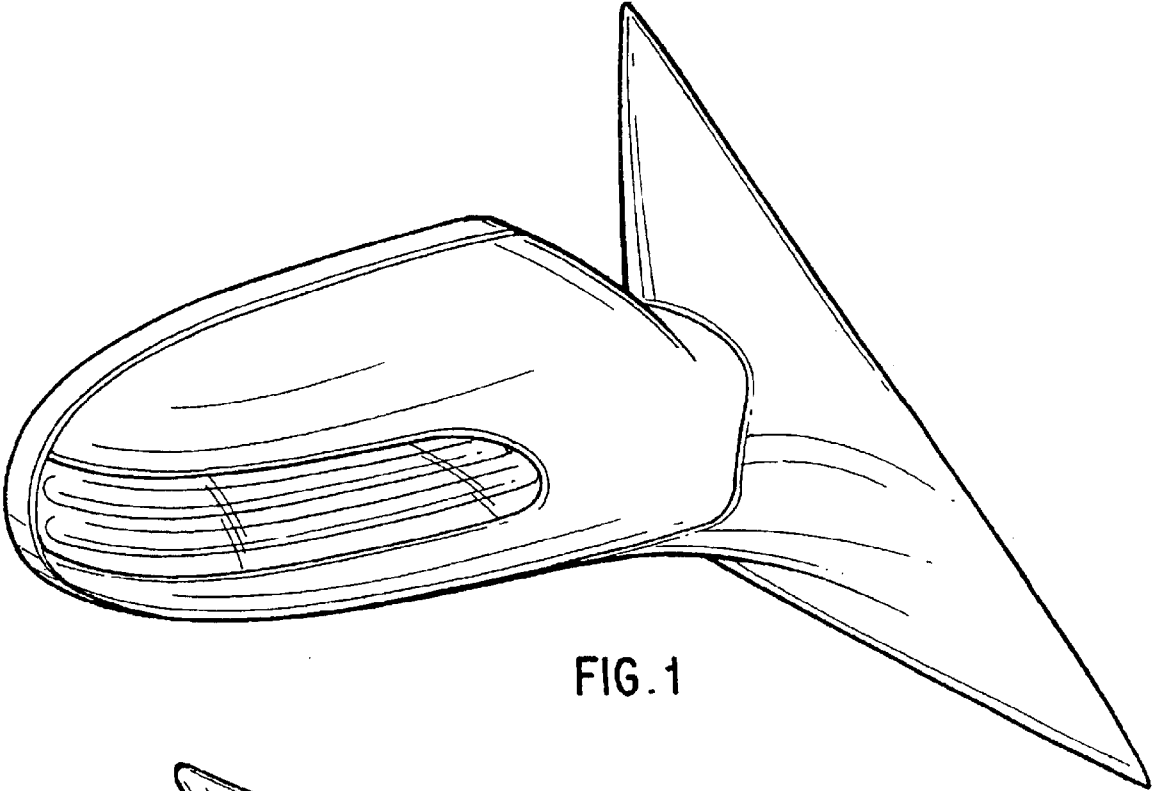

FIG. 1

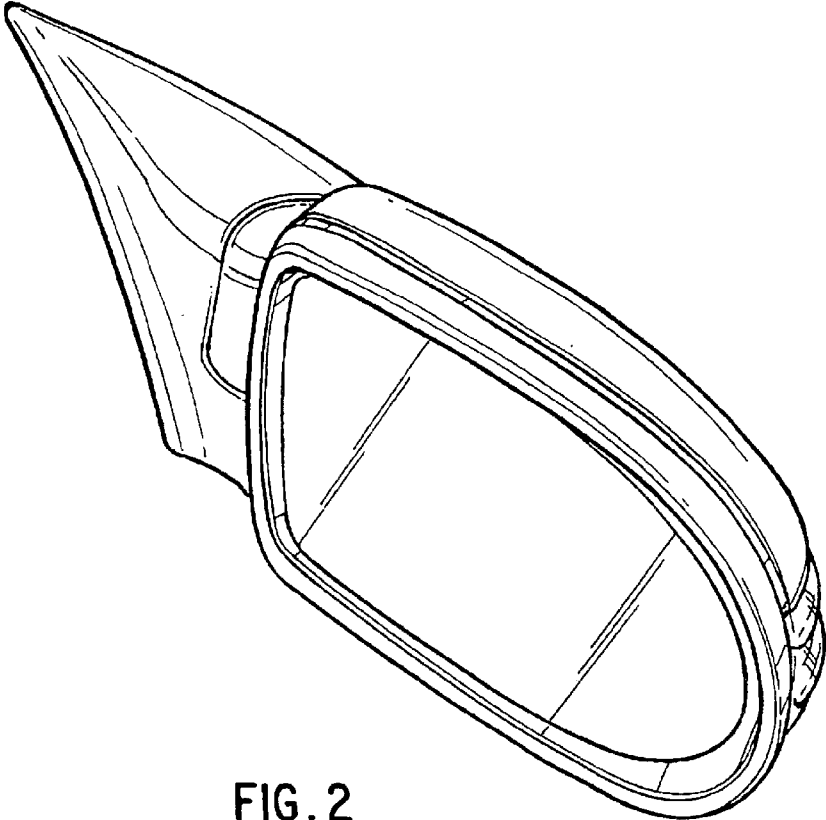

FIG. 2

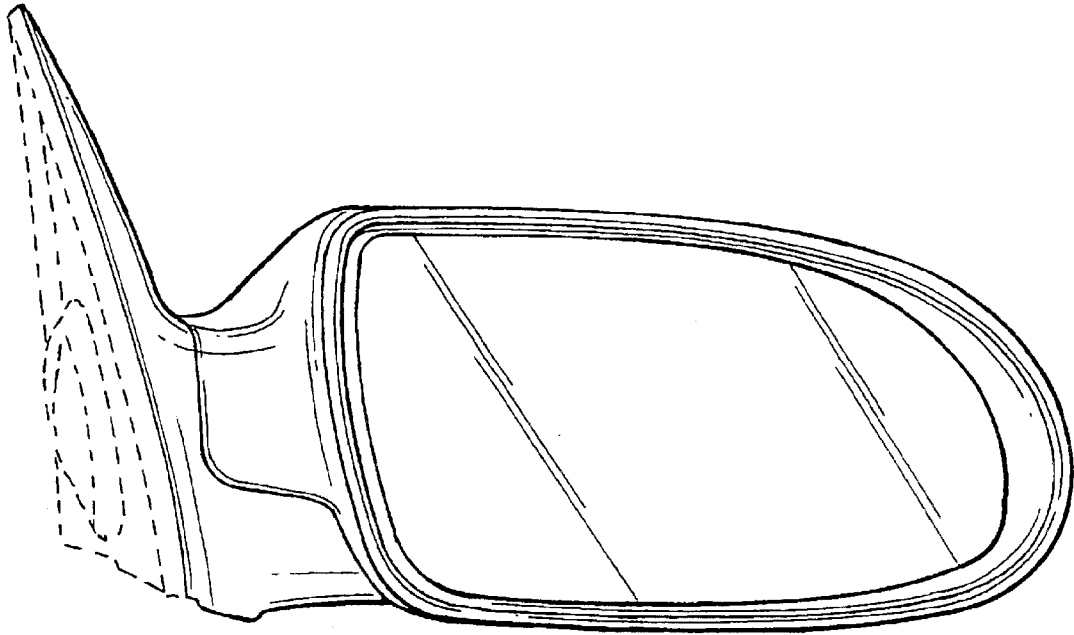

FIG. 3

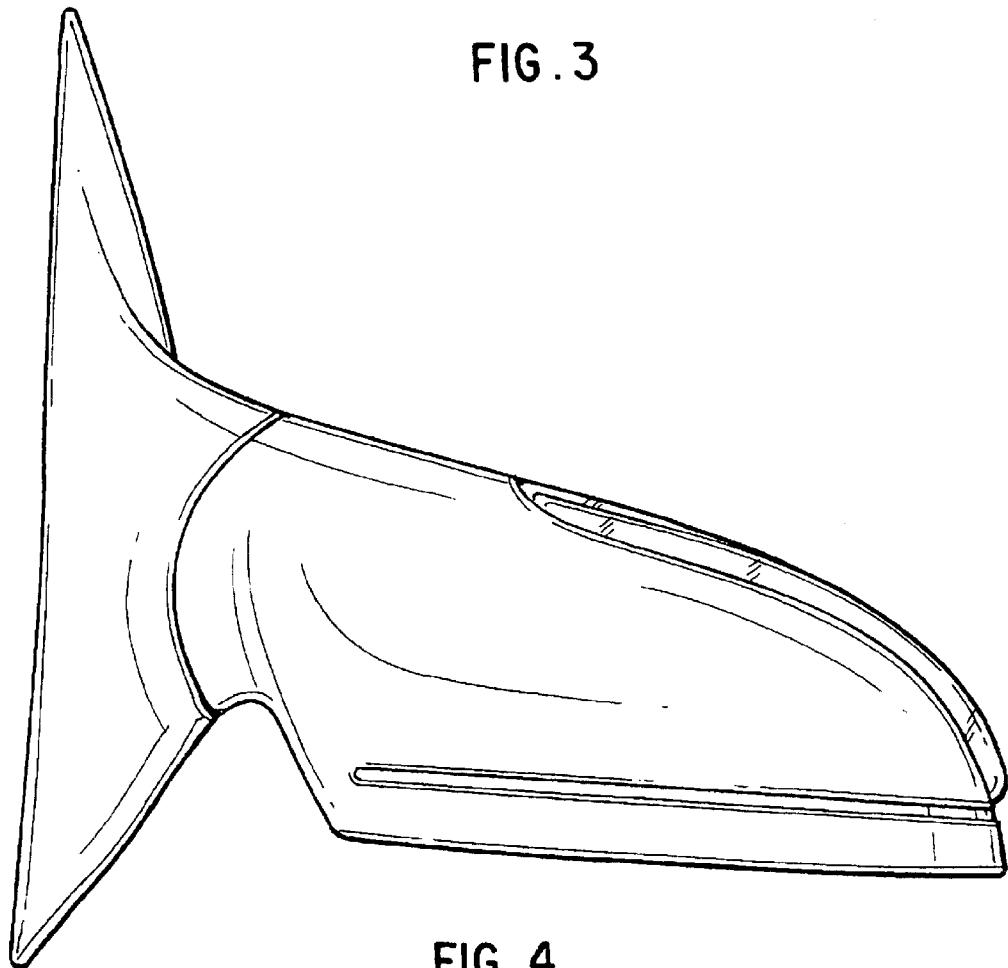

FIG. 4

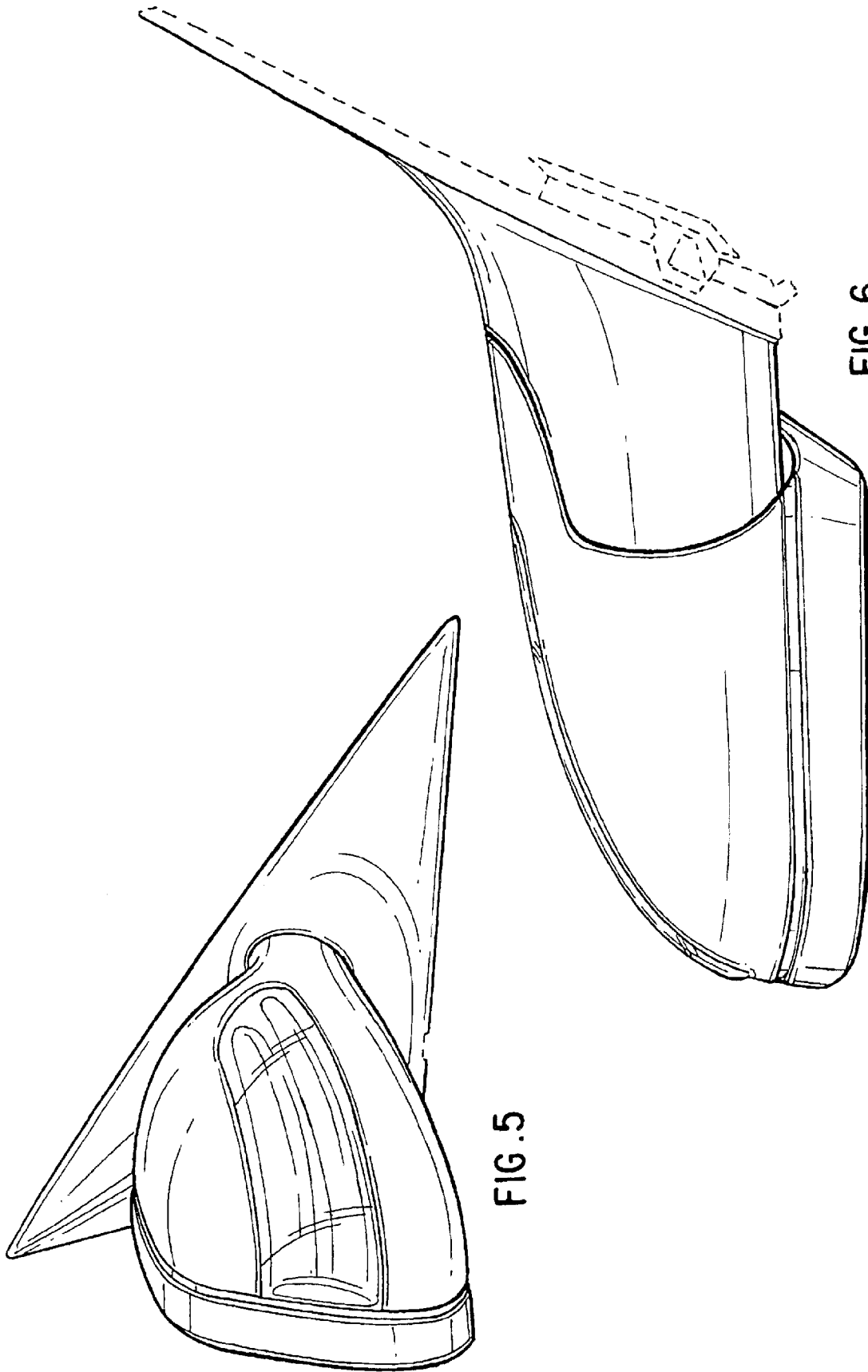

FIG. 5

FIG. 6

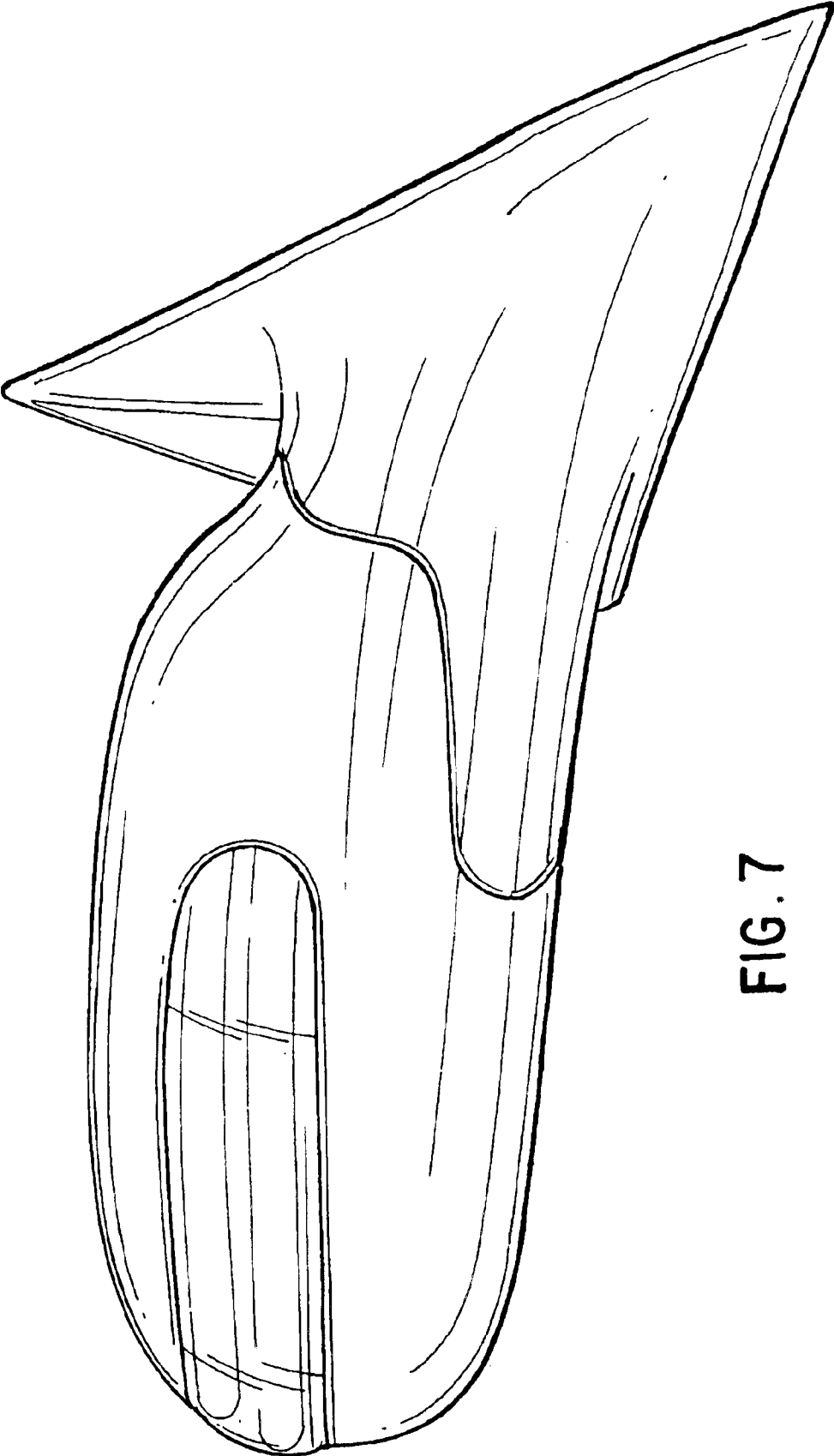

FIG. 7

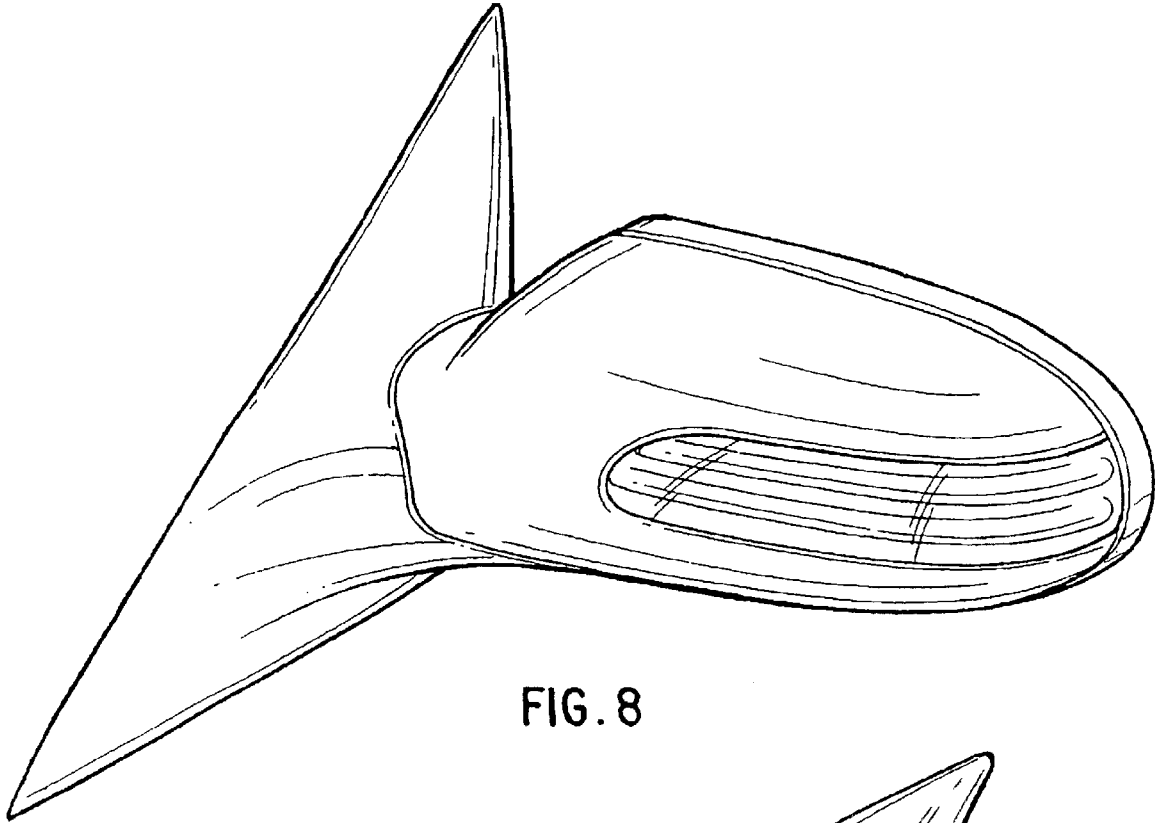

FIG. 8

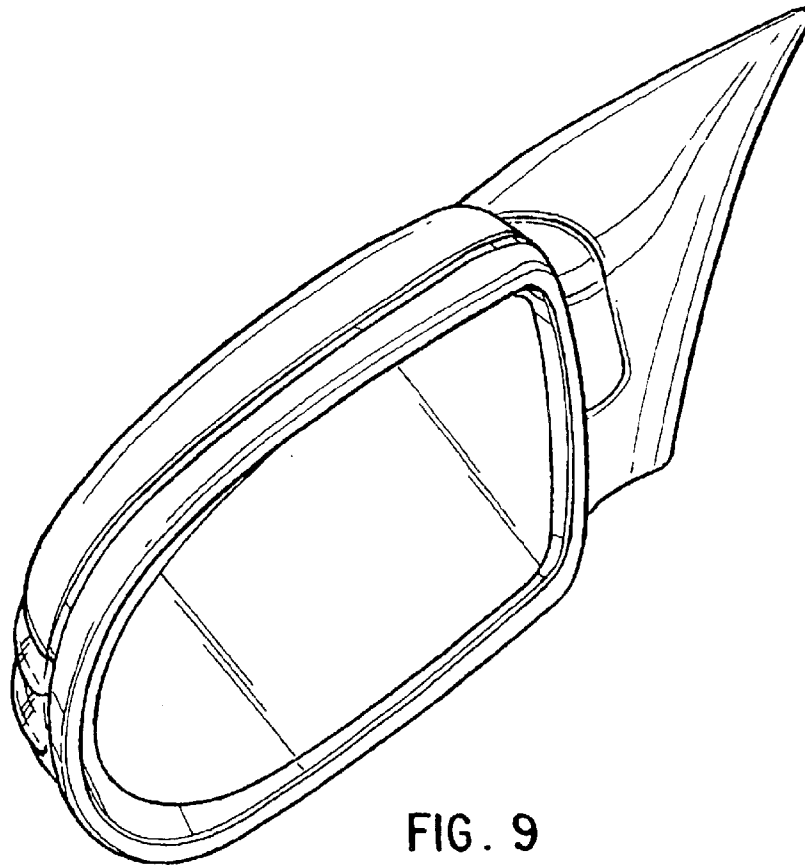

FIG. 9

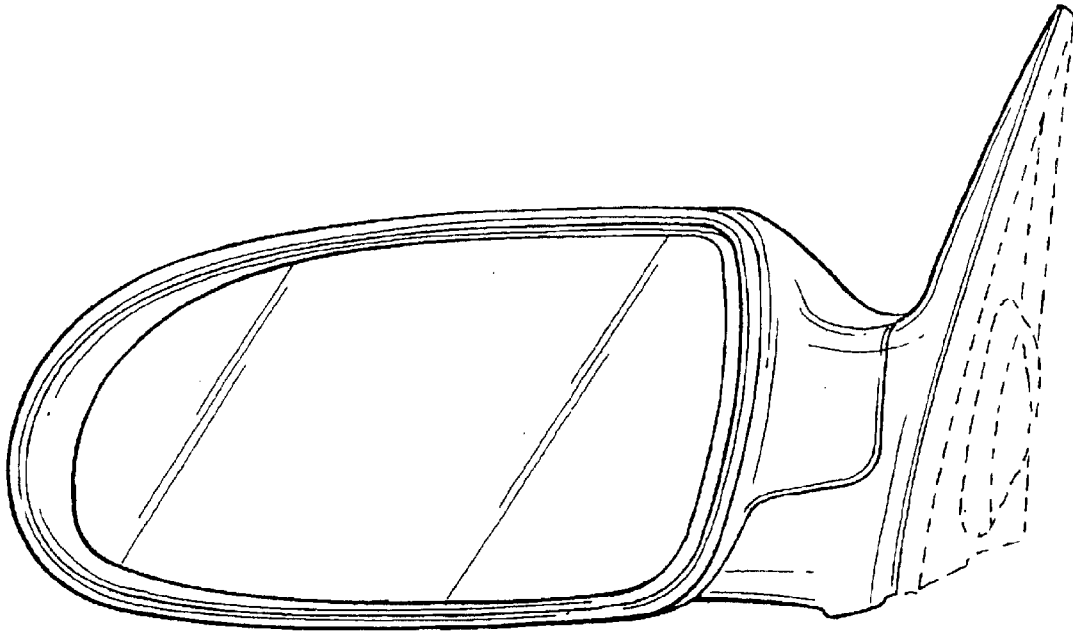

FIG. 10

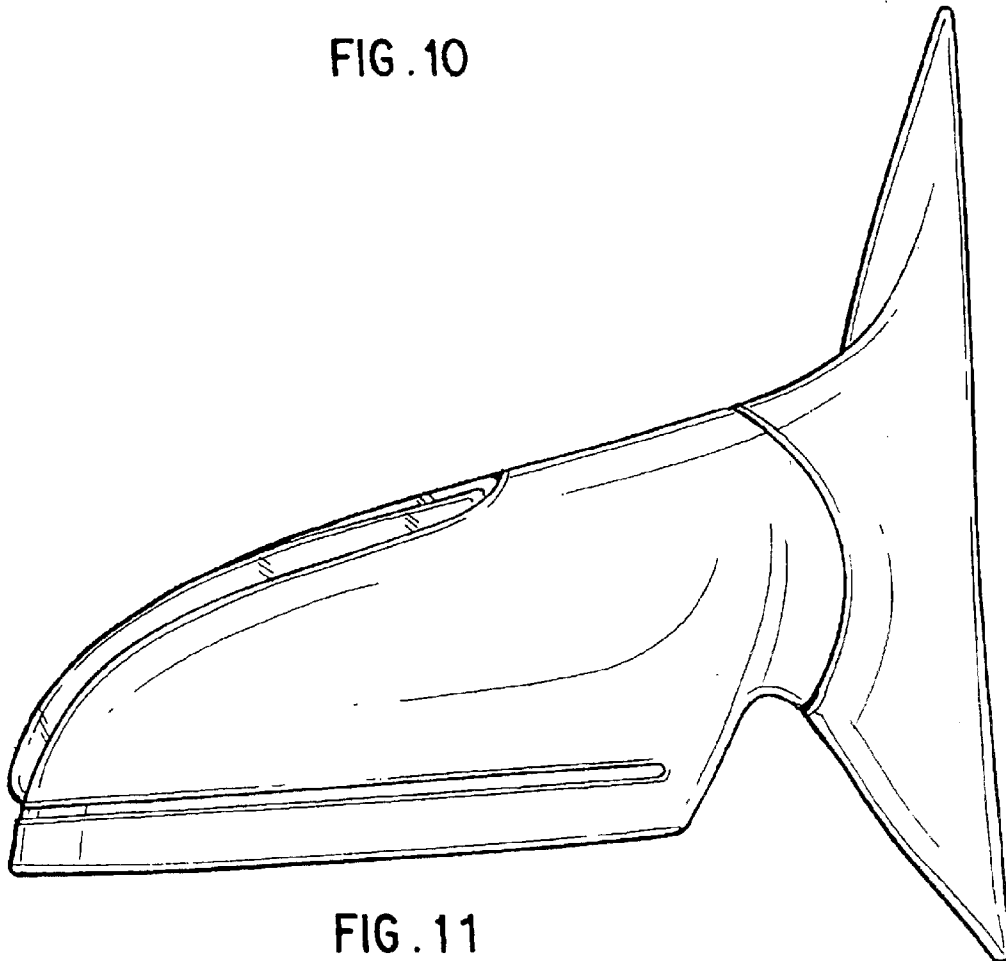

FIG. 11

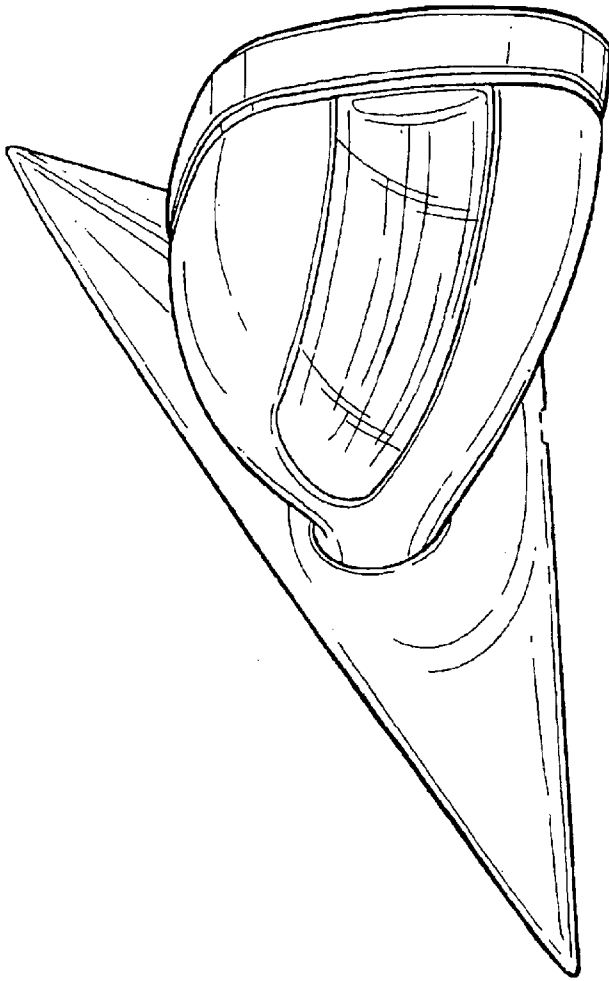

FIG. 12

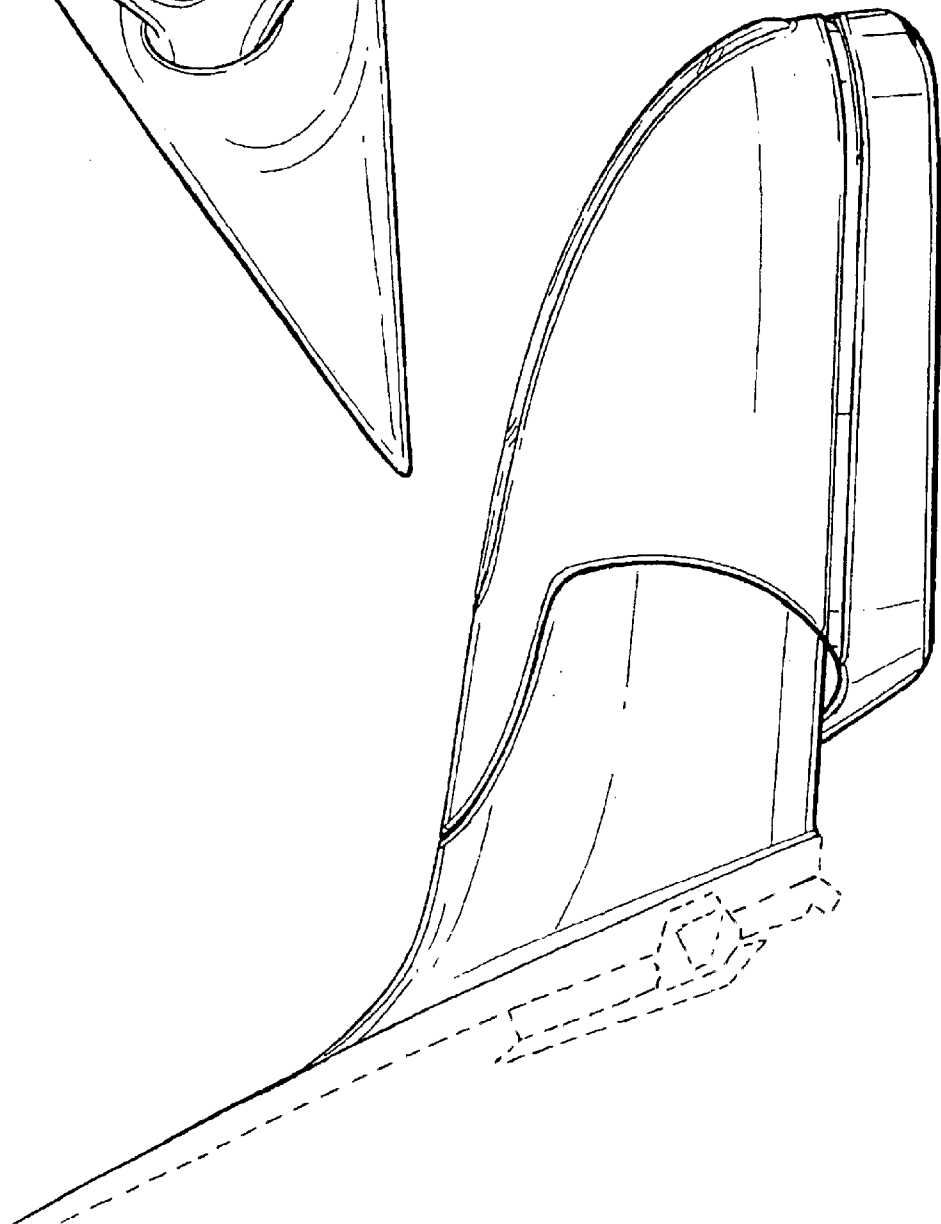

FIG. 13

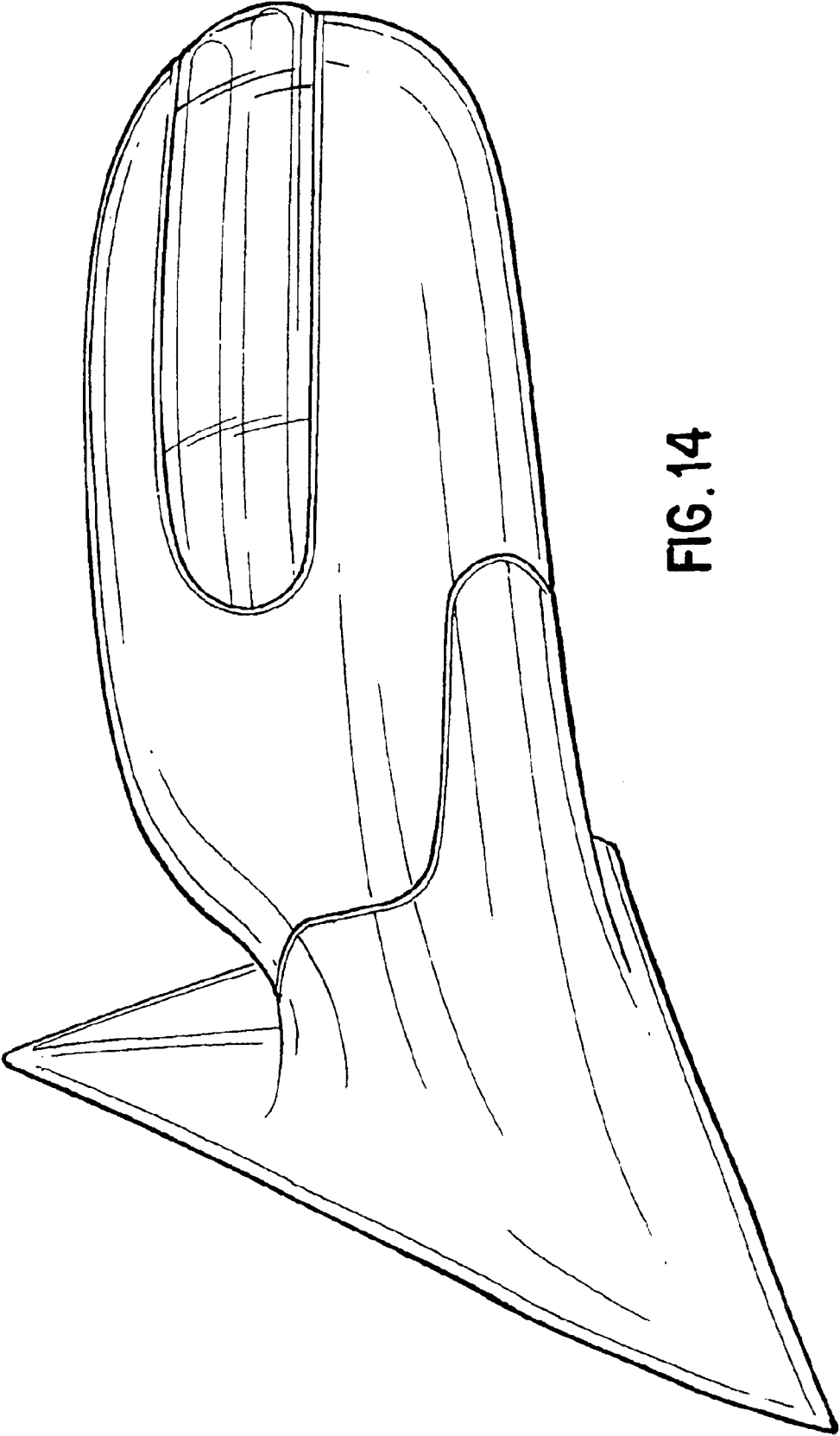

FIG. 14