

(12) PATENT
(19) AUSTRALIAN PATENT OFFICE

(11) Application No. AU 199746328 B2
(10) Patent No. 739575

(54) Title
Vehicle winch arrangement

(51)⁷ International Patent Classification(s)
B66D 001/00 B66D 001/36

(21) Application No: **199746328**

(22) Application Date: **1997.10.14**

(87) WIPO No: **WO99/19245**

(43) Publication Date : **1999.05.03**

(43) Publication Journal Date : **1999.07.01**

(44) Accepted Journal Date : **2001.10.18**

(71) Applicant(s)
John Arthur Foers

(72) Inventor(s)
John Arthur Foers

(74) Agent/Attorney
SPRUSON and FERGUSON,GPO Box 3898,SYDNEY NSW 2001

(56) Related Art
US 5393194
US 4127295
US 3788605



<p>(51) International Patent Classification ⁶ : B66D 1/00, 1/36</p>	<p>A1</p>	<p>(11) International Publication Number: WO 99/19245 (43) International Publication Date: 22 April 1999 (22.04.99)</p>
<p>(21) International Application Number: PCT/GB97/02829 (22) International Filing Date: 14 October 1997 (14.10.97) (71)(72) Applicant and Inventor: FOERS, John, Arthur [GB/GB]; Foers Engineering, Gateway Industrial Estate, The Gateway, Parkgate, Rotherham, South Yorkshire S62 6JZ (GB). (74) Agents: MURGATROYD, Susan, Elizabeth et al.; Baron & Warren, 18 South End, Kensington, London W8 5BU (GB).</p>	<p>(81) Designated States: AL, AM, AT, AU, AZ, BA, BB, BG, BR, BY, CA, CH, CN, CU, CZ, DE, DK, EE, ES, FI, GB, GE, GH, HU, ID, IL, IS, JP, KE, KG, KP, KR, KZ, LC, LK, LR, LS, LT, LU, LV, MD, MG, MK, MN, MW, MX, NO, NZ, PL, PT, RO, RU, SD, SE, SG, SI, SK, SL, TJ, TM, TR, TT, UA, UG, US, UZ, VN, YU, ZW, ARIPO patent (GH, KE, LS, MW, SD, SZ, UG, ZW), Eurasian patent (AM, AZ, BY, KG, KZ, MD, RU, TJ, TM), European patent (AT, BE, CH, DE, DK, ES, FI, FR, GB, GR, IE, IT, LU, MC, NL, PT, SE), OAPI patent (BF, BJ, CF, CG, CI, CM, GA, GN, ML, MR, NE, SN, TD, TG).</p> <p>Published <i>With international search report.</i></p>	

(54) Title: VEHICLE WINCH ARRANGEMENT

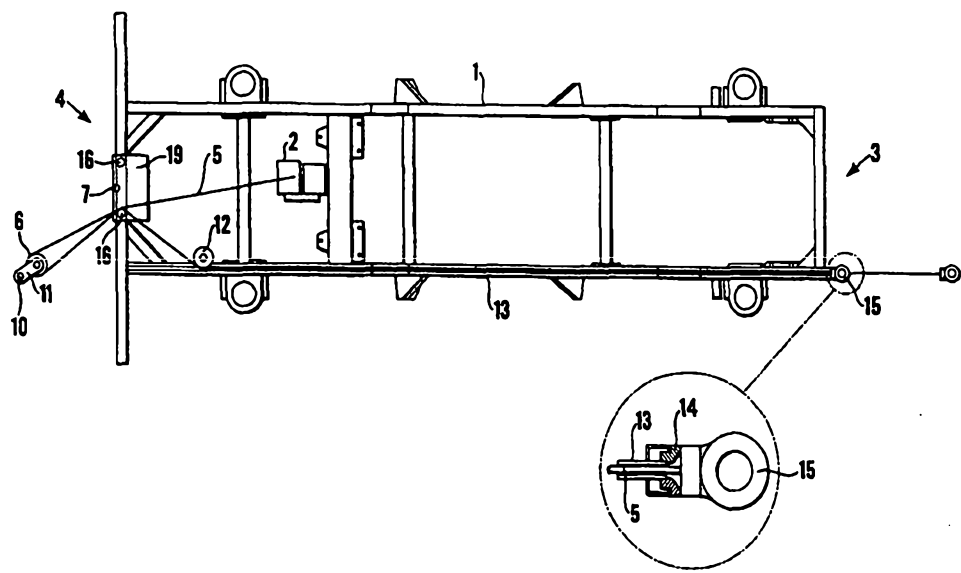

(57) Abstract

A winch arrangement fitted to a vehicle chassis (1) comprises a winch (2) mounted at an intermediate position between chassis front end (3) and chassis rear end (4), and a winch cable (5) extended from the winch (2) to a pulley block (6) mounted on the chassis rear end (4). The pulley block (6) turns the cable (5) and the cable is passed through a fore and aft guide member (13) to the chassis front end (3). Stop members (14, 15) are provided to stop recovery of the cable (5) on to the winch (2) in a predetermined position. For rearward winching, the pulley block (6) is dismounted by a removable pin (7) and cable attachment (11) is secured to a load or an anchor point, and for forward winching cable attachment (15) can be pulled out and secured to a load or an anchor point whilst pulley block (6) is left mounted. For simultaneous rearward and forward winching, both cable attachments (11, 15) can be secured to a load or an anchor point.

VEHICLE WINCH ARRANGEMENT

FIELD OF THE INVENTION

5 The present invention relates to a vehicle winch arrangement and more specifically to such an arrangement which enables a pull to be applied selectively in either the fore or aft direction of the vehicle.

BACKGROUND OF THE INVENTION

10 One example of a winch arrangement of this kind is disclosed in US Patent No. 4,127,295, in which a cable winch unit is fitted directly behind the front bumper of a truck. The winch unit comprises a winch from which a cable extends towards the front of the truck to provide forward pulling and cable guide pulleys mounted in the front bumper which enable the cable to be guided along the front face and around one end of the
15 bumper to be directed towards the rear of the truck for rearward pulling.

 However, this known arrangement requires the cable to be routed around the external side of the truck during a rearward pull which could cause damage to the vehicle in the likely event of an accidental slew. It also only enables a forward or a rearward pull to be carried out, but not simultaneous pulling in both directions. The positioning of the
20 winch directly behind the front bumper could also cause a number of problems. These problems may include poor winching stability due to the highest loads being borne by the corner bumper pulleys which would be cantilevered out from the ends of the front bumper, thus creating large bending and twisting moments on a relatively frail component and rendering the vehicle prone to unintentional slewing; imperfect layering of the cable
25 on the winch drum when being used for a rear or side pull as the cable would tend to build up on one side of the drum; and increase in the vehicle's moment of inertia in pitch and yaw which would have an adverse effect on the vehicle's handling characteristics.

 US-A-5393194 discloses a game-handling apparatus mounted on a four-wheel all-terrain vehicle to which a winch is fixed. The apparatus includes a first roller mounted
30 on the front of the vehicle above the winch for guiding the winch line from the vehicle upwardly, a roll bar secured to the vehicle and fitted with a middle pulley for guiding the winch line rearwardly, and a rear roller attached to the rear of the vehicle for guiding the winch line downwardly behind the vehicle. A game animal can be attached to the end of the winch line to lift the animal onto the vehicle.

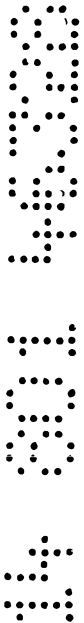

OBJECT OF THE INVENTION

It is an object of the present invention to overcome or ameliorate some of the disadvantages of the prior art, or at least to provide a useful alternative.

5

SUMMARY OF THE INVENTION

Accordingly, one aspect of the present invention consists in a vehicle fitted with a winch having a winch cable extendable from the vehicle to apply a pull in one fore and aft direction of the vehicle, and guide means about which the cable can be turned so as
10 selectively to apply a pull in the opposite direction, the guide means comprising a guide member at or adjacent one end of said vehicle and about which the cable leading from the winch is turned towards the opposite end of the vehicle, and fore and aft guide means guiding the cable to the opposite end of the vehicle, characterised in that side guide member is removable from the vehicle for attachment to a load or an anchor point, and in
15 that stop means are provided on the cable for stopping recovery of the cable on to the winch in a predetermined direction.

The present invention, at least in a preferred embodiment, thus provides three basic winching modes comprising:

20 1) to carry out pulling in one direction, the cable is extended out of the end of the fore and aft guide means and it is secured to a load or an anchor point, whilst the guide member is on the vehicle;

2) to carry out pulling in the opposite direction, the guide member is removed and secured to a load or an anchor point, whilst the cable remains in the fore and aft guide means; and

25 3) to carry out pulling simultaneously in both directions, both the guide member and the cable end are extended out and secured to a load or an anchor point.

In a preferred embodiment, the winch is provided at an intermediate position between the fore and aft of the vehicle, so as to minimise the moment of inertia of the vehicle which optimises the vehicle's handling characteristics and maximises winching
30 stability.

The guide member and/or the cable end may be provided with means, such as a hook or an eye, for connection to a load or any suitable anchor point, such as a tree. The connection means at the cable end may also form the stop means for stopping recovery of the cable on to the winch. The fore and aft guide means may comprise a tubular member

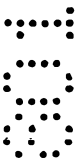
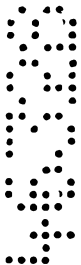

through which the cable passes, and it preferably forms part of the chassis of the vehicle. The guide member preferably comprises pulley means.

Additional cable guide means may be mounted on the end of the vehicle on either side of the turning guide member and/or on the fore and aft guide means at the opposite end of the vehicle, so as to guide the cable when one or both of the guide member and the cable end are extended out with respect to the vehicle.

From another aspect of the invention, there is provided a kit of parts for a winch arrangement for a vehicle, comprising:

a winch mountable on the vehicle and having a winch cable extendable from the winch to enable a pull to be applied in one direction;

a guide member about which the cable is intended to be turned so as selectively to enable a pull to be applied in the opposite direction; and

stop means provided on the cable for stopping recovery of the free end of the cable on to the winch; wherein the guide member is removably mounted in a housing and the housing is adapted to be fixed at or adjacent one end of the vehicle such that, in use, the guide member is removable from the housing fixed to the vehicle so as to enable the guide member to be attached to a load or an anchor point.

From a still further aspect, the invention consists in a chassis for a vehicle, said chassis being fitted with a winch having a winch cable extendable from the chassis to apply a pull in one fore and aft direction of the chassis, and guide means about which the cable can be turned so as selectively to apply a pull in the opposite direction, the guide means comprising a guide member at or adjacent one end of the chassis and about which the cable leading from the winch is turned towards the opposite direction of the chassis, and fore and aft guide means guiding the cable to the opposite end of the chassis, characterised in that said guide member is removable from the chassis for attachment to a load or an anchor point, and in that stop means are provided on the cable for stopping recovery of the cable on to the winch in a predetermined direction.

BRIEF DESCRIPTION OF THE DRAWINGS

A preferred embodiment of the invention will now be described, by way of example only, with reference to the accompanying drawings, wherein;

Figure 1 shows a plan view of a chassis of a vehicle in accordance with one embodiment of the invention;

Figure 2 shows a plan view of the rear end of the chassis in one winching mode;

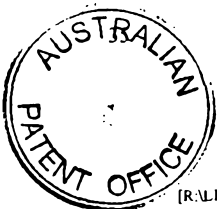

Figure 3 shows a plan view of the chassis rear end in another winching mode;

Figure 4 shows a view along line I-I of Figure 3;

Figure 5 shows a schematic perspective view of the winch arrangement; and

5 Figure 6 shows some of the winching modes made possible by embodiments of the present invention.

DETAILED DESCRIPTION OF THE PREFERRED EMBODIMENTS

Referring now to Figures 1 to 5, a winch arrangement is shown fitted to a chassis
10 1 of a vehicle (not shown). The winch arrangement comprises a winch 2 mounted on the chassis 1 at an intermediate position between chassis front end 3 and chassis rear end 4. A winch cable 5 extends from the winch 2 to a dismountable guide member comprising a pulley block 6 mounted in a housing 19 on the chassis 1 at the rear end 4. The pulley block 6 is mounted in the housing by means of a removable pin 7 which passes through
15 aligned holes 8, 9 in the housing 19 and through eye 10 in a cable attachment 11 secured to the pulley block 6. The pin 7 is removable from the housing by pulling out a small quick release pin 17 and, once the pin 7 has been removed, the pulley block 6 and cable attachment 11 can be dismounted.

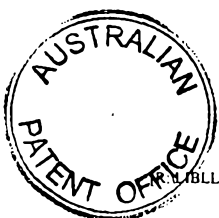
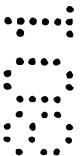

from the housing. The winch cable 5 passes around the pulley block 6 and is thereby turned towards the chassis front end 3 and is passed, via a guide roller 12, through a fore and aft guide member 13 mounted within the chassis 1.

5 At the front end 3, stop members 14 are mounted on the end of the fore and aft guide member 13. These stop members cooperate with a cable attachment 15, such as a hook or an eye, secured to the end of the winch cable 5 so as to prevent the cable end from passing back down the fore and
10 aft guide member 13 to the rear end 4.

Circlip and roller assemblies 16 are mounted in the housing 19 at the chassis rear end 4 on either side of the pulley block 6 so as to guide the winch cable 5 when a rearward pull is performed in the direction of the
15 longitudinal axis of the chassis 1, as shown in Figure 1, or at certain angles with respect to the longitudinal axis. At the front end 3, the stop members 14 are shaped so as to carry out the same function when a forward pull is performed at an angle to the longitudinal axis of the chassis.

20 In use of the winch arrangement, there are three basic winching modes as follows:-

1) to carry out a forward pull only, the pulley block 6 is left secured in the housing at the chassis rear end 4, as shown in Figure 3, and the cable attachment 15 is
25 extended out of the fore and aft guide member 13 and secured to either a load or a suitable anchor point;

2) to carry out a rearward pull only, the pulley block 6 is dismantled from the housing, as shown in Figure 2, and the pulley block 6 and cable attachment 11 are
30 extended out and secured to either a load or a suitable anchor point, whilst recovery of the cable 5 through the fore and aft guide member 13 is prevented by the stop members 14 cooperating with the cable attachment 15; and

3) to carry out simultaneous forward and rearward
35 pull, the pulley block 6 is dismantled and both the pulley block 6 and the cable attachment 15 are extended out in opposite directions and secured to a load or an anchor

point.

If the load or anchor point is located at a position offset from the longitudinal axis of the vehicle chassis, the rollers 16 and/or the stop members 14 aid in guiding the winch cable 5 in the required direction, as shown in Figure 1.

Figure 5 shows a variety of winching modes made possible by the present winch arrangement. These are just some examples of the possible modes and many others could also be achieved. Figure 6.1 shows the layout of a vehicle 20, in accordance with the present invention, two loads 21, 22 and possible ground anchors 23 which may be applied or be naturally occurring fixed points, such as trees. Figures 6.2 to 6.4 show simple forward or rearward pulls by securing to anchor points 23. In Figures 6.3 and 6.4, a mechanical advantage of 2:1 is obtained, and in Figure 6.4, another pulley 24 is used and the cable end is secured back onto the other side of the front of the vehicle 20. In Figures 6.5 to 6.8, various modes are shown for recovery of either a single load or a double load providing mechanical advantages of 2:1 or 3:1. Figure 6.9 shows recovery of a load onto a trailer 25. Figures 6.10 to 6.13 show various slew arrangements in which the cable is secured to one or more anchor points offset from the longitudinal axis of the vehicle 20, and Figures 6.14 and 6.15 show side pull arrangements in which the cable is secured to one or more anchor points located at up to 90° to the longitudinal axis of the vehicle 20.

From the foregoing, it can be readily seen that the present invention at least in a preferred embodiment has many advantages, which preferably include the following:

1. The winch cable is permanently located in the chassis of the vehicle, thereby removing the necessity to thread the cable around pulleys in order to winch in the desired direction. The cable attachment is simply pulled from its stored position at the front of the chassis for a forward pull, or the pulley block and cable attachment is

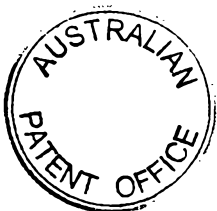

pulled out of the rear of the chassis for a rearward pull.

2. It allows a simultaneous front and rear pull without the need to attach additional components to the winch cable.

5 3. It allows the winch to be situated in a substantially central location of the vehicle, which has the following effects:-

10 3.1 it minimises the vehicle's moment of inertia in pitch and yaw, which optimises the vehicle's handling characteristics. Mounting a heavy winch at the extreme front or rear of a vehicle has an adverse effect on handling;

15 3.2 it keeps the front and rear of the vehicle free from projections so as not to spoil approach and departure angles. These are important features in an off-road vehicle and this arrangement has the ultimate approach and departure angles, both being 90°. Additionally, it does not compromise the off-road performance of the vehicle;

20 3.3 the absence of a front mounted winch makes for a more pedestrian-friendly vehicle, which is now a very important criterion for vehicle designers;

3.4 the relatively large distance between the winch drum and the first change in direction of the cable allows perfect layering of the cable onto the drum, thus optimising the winch's performance and cable life;

25 3.5 winch security is enhanced as the winch can only be removed from inside the vehicle;

3.6 the winch is totally enclosed and protected from the elements and other external forces; and

30 3.7 it does not affect a vehicle's frontal deformation characteristics during impact. This is an important feature if airbag deployment has to be considered.

4. The winch cable passes down the inside of the chassis in a guide tube, out of harm's way, and reduces the dangers from cable recoil in the event of a tensile failure.

35 5. The winch loads are borne by substantial chassis members.

6. Winching stability is maximised by having the

cable loads imposed on the vehicle close to its centre line,

7. All pulleys are contained within the chassis when the vehicle is not winching.

5 8. The number of primary winching modes is manifold and, when subsequent combinations are taken into account, the number will probably run into hundreds.

10 9. It is possible simultaneously to winch and also to drive the vehicle in the opposite direction to the cable movement so as to enable a more suitable anchor position to be obtained if necessary when used in the mode shown in Figure 6.6.

The claims defining the invention are as follows:

1. A vehicle fitted with a winch having a winch cable extendable from the
5 vehicle to apply a pull in one fore and aft direction of the vehicle, and guide means about
which the cable can be turned so as selectively to apply a pull in the opposite direction,
the guide means comprising a guide member at or adjacent one end of the vehicle and
about which the cable leading from the winch is turned towards the opposite direction of
10 the vehicle, and fore and aft guide means guiding the cable to the opposite end of the
vehicle, wherein said guide member is removable from the vehicle for attachment to a
load or anchor point, and wherein stop means are provided on the cable for stopping
recovery of the cable on to the winch in a predetermined direction.

2. A vehicle as claimed in claim 1, wherein the winch is provided at an
15 intermediate position between the fore and aft of said vehicle.

3. A vehicle as claimed in claim 1 or 2, wherein the guide member and/or
the cable end are provided with means for connection to a load or an anchor point.

4. A vehicle as claimed in claim 3, wherein the connection means at the
20 cable end also form the stop means for stopping recovery of the cable on to the winch.

5. A vehicle as claimed in any preceding claim, wherein the fore and aft
guide means comprises a tubular member through which the cable passes.

6. A vehicle as claimed in any preceding claim, wherein the fore and aft
25 guide means forms part of the chassis of the vehicle.

7. A vehicle as claimed in any preceding claim, wherein the guide member
30 comprises pulley means.

8. A vehicle as claimed in any preceding claim, wherein additional cable
guide means are mounted on the end of the vehicle on either side of said guide member so
as to guide the cable when the guide member is extended out with respect to the vehicle.

35



9. A vehicle as claimed in any preceding claim, wherein additional cable guide means are provided on the fore and aft guide means at said opposite end of said vehicle for guiding the cable when the cable end is extended out with respect to the
5 vehicle.

10. A kit of parts for a winch arrangement for a vehicle, comprising:
a winch mountable on the vehicle and having a winch cable extendable from the winch to enable a pull to be applied in one direction;
10 a guide member about which the cable is intended to be turned so as selectively to enable a pull to be applied in the opposite direction; and
stop means provided on the cable for stopping recovery of the free end of the cable on to the winch; wherein the guide member is removably mounted in a housing and the housing is adapted to be fixed at or adjacent one end of the vehicle such that, in use,
15 the guide member is removable from the housing fixed to the vehicle so as to enable the guide member to be attached to a load or an anchor point.

11. A chassis for a vehicle, said chassis being fitted with a winch having a winch cable extendable from the chassis to apply a pull in one fore and aft direction of the chassis, and guide means about which the cable can be turned so as selectively to apply a
20 pull in the opposite direction, the guide means comprising a guide member at or adjacent one end of the chassis and about which the cable leading from the winch is turned towards the opposite direction of the chassis, and fore and aft guide means guiding the cable to the opposite end of the chassis, wherein said guide member is removable from
25 the chassis for attachment to a load or an anchor point, and wherein stop means are provided on the cable for stopping recovery of the cable on to the winch in a predetermined direction.

12. A vehicle, substantially as herein described with reference to any one of the embodiments of the invention shown in the accompanying drawings.

13. A kit of parts for a winch arrangement for a vehicle, substantially as herein described with reference to any one of the embodiments of the invention shown in the accompanying drawings.



14. A chassis for a vehicle, substantially as herein described with reference to any one of the embodiments of the invention shown in the accompanying drawings.

5

Dated 14 August, 2001

John Arthur Foers

Patent Attorneys for the Applicant/Nominated Person

SPRUSON & FERGUSON

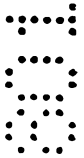
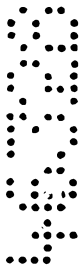

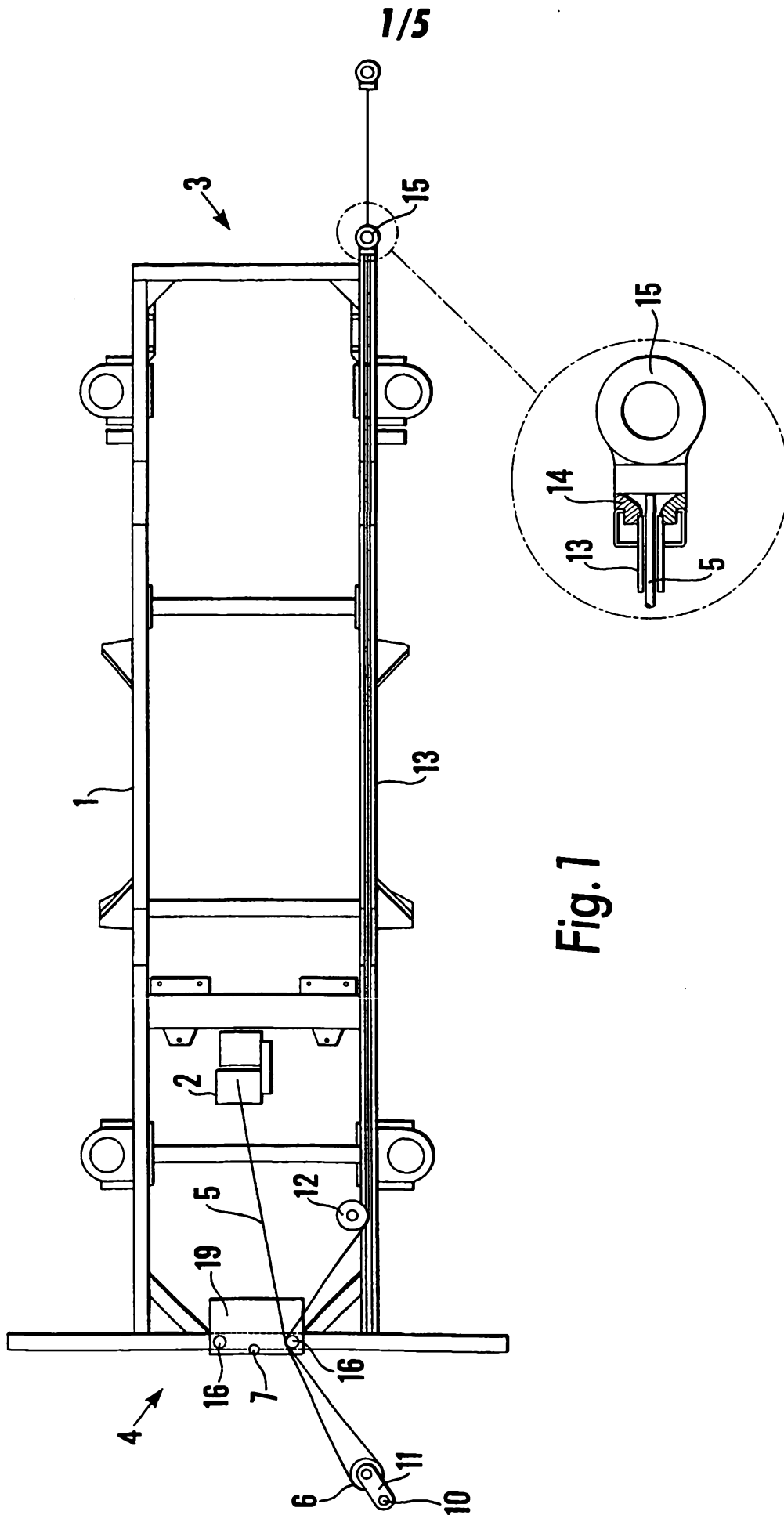

Fig. 1

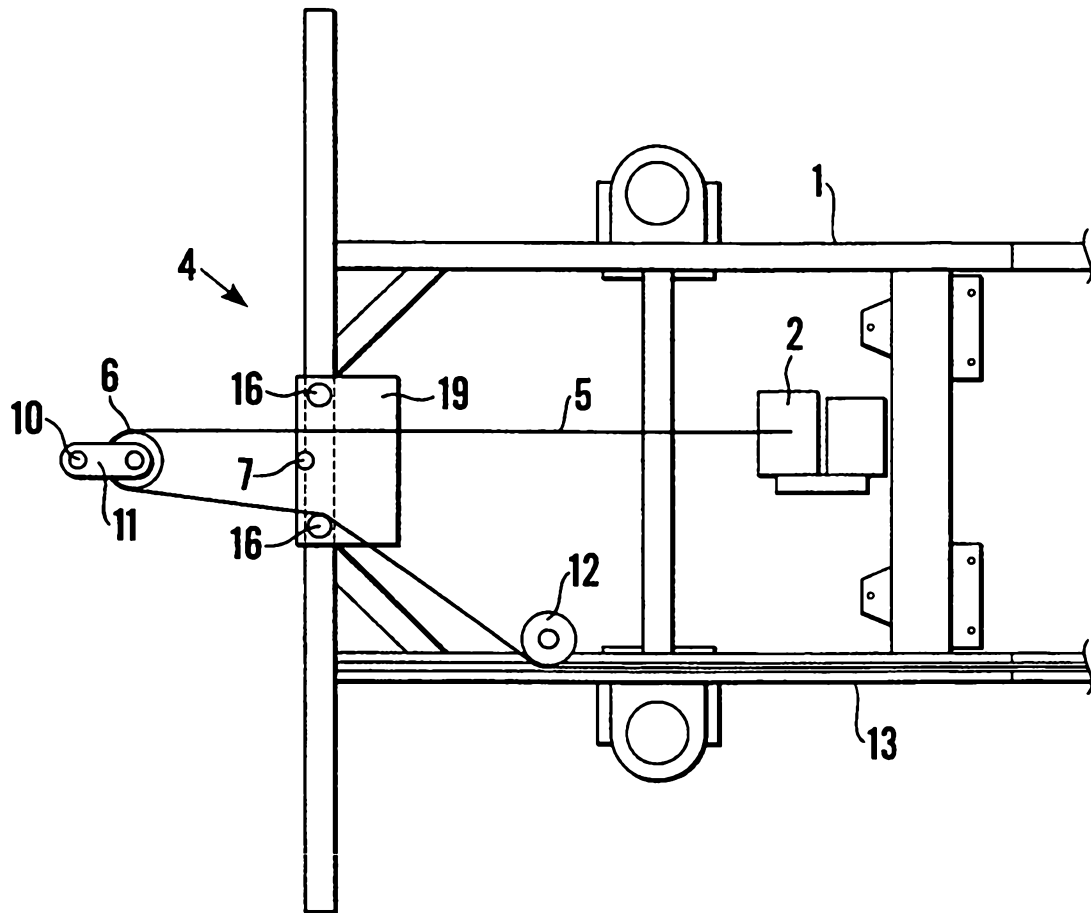

Fig.2

3/5

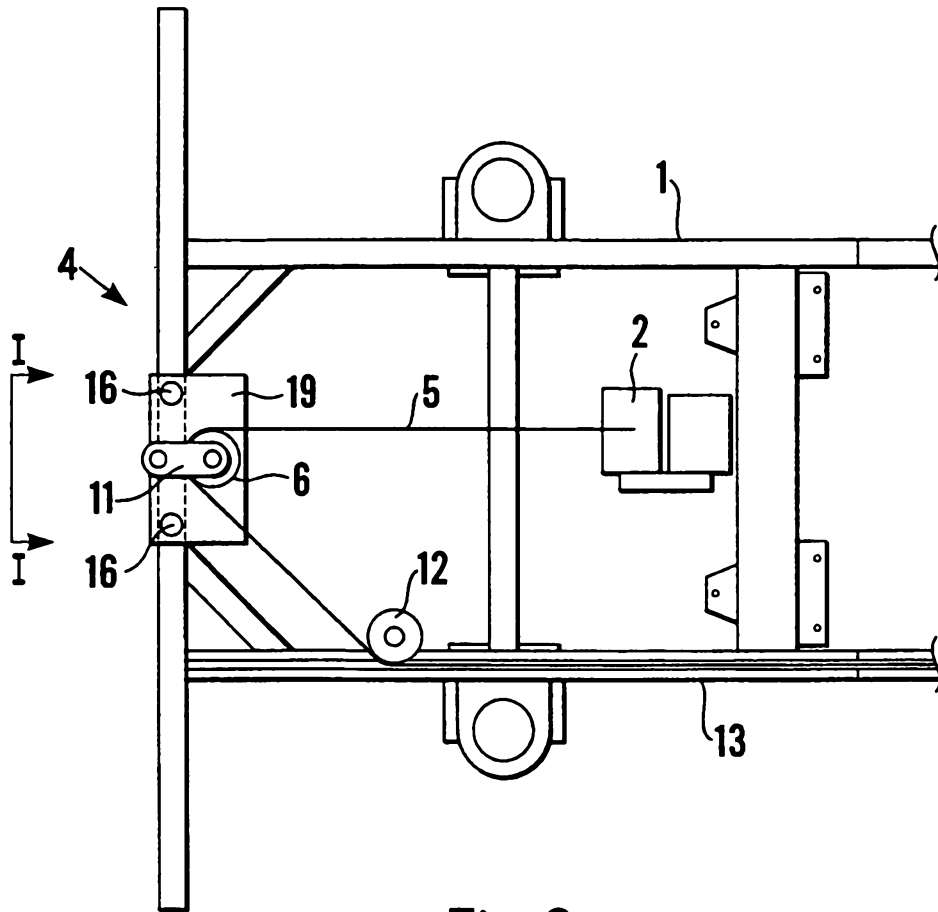

Fig. 3

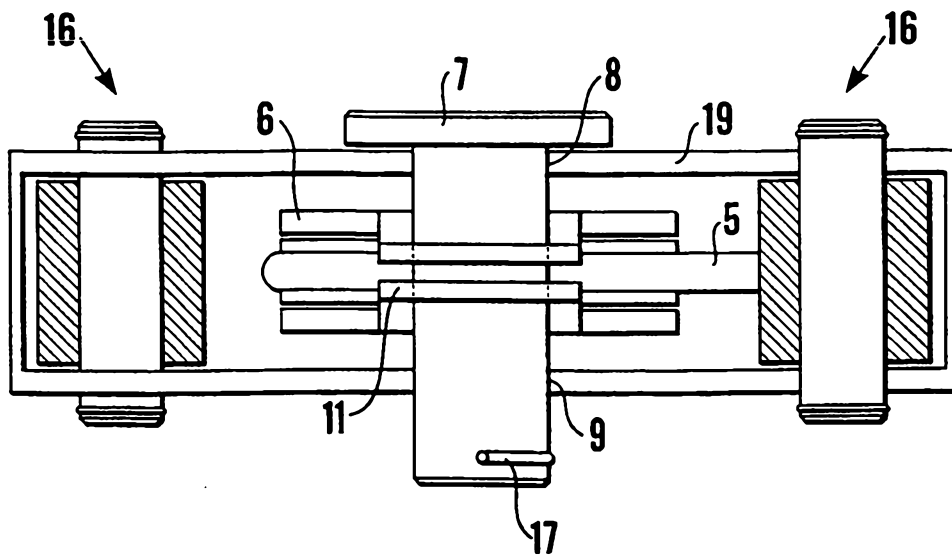

Fig. 4

4/5

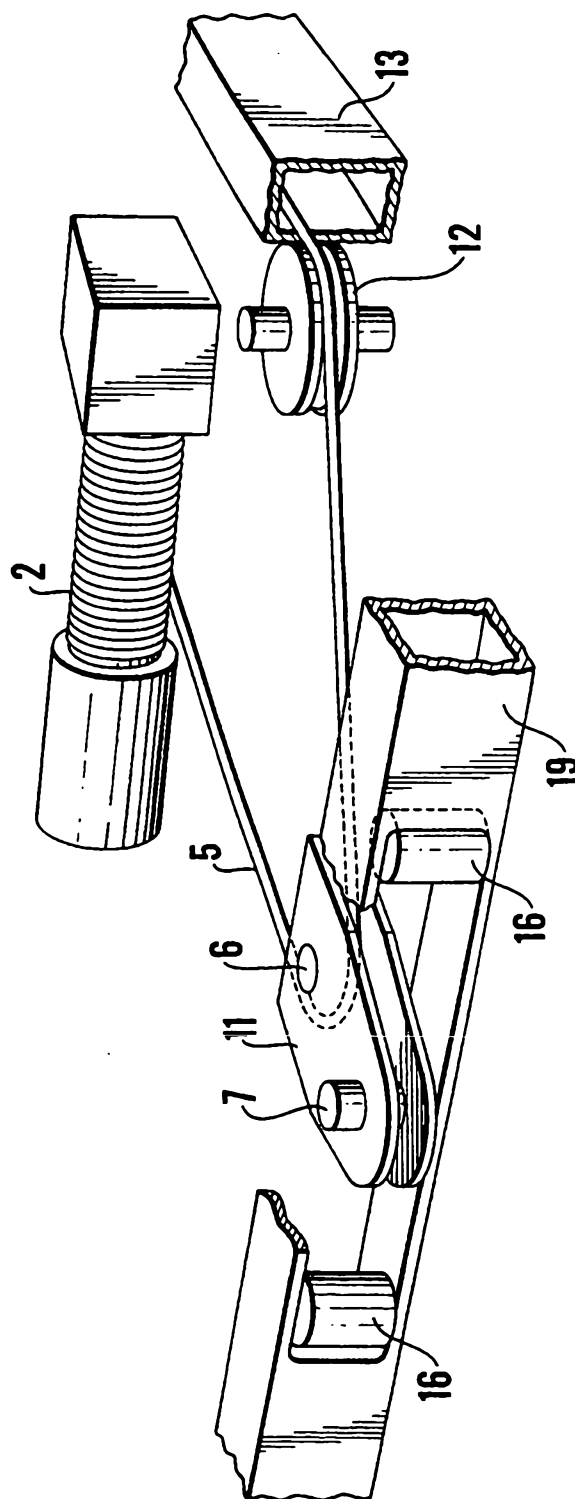

Fig.5

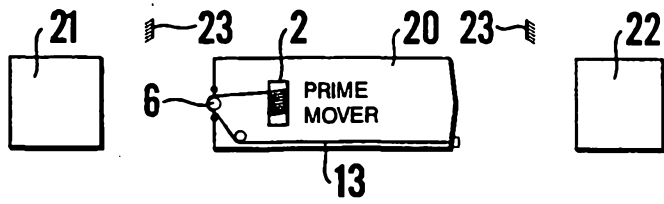

Fig. 6.1

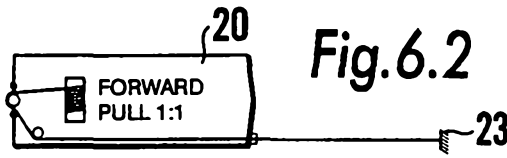

Fig. 6.2

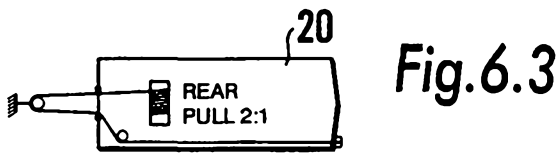

Fig. 6.3

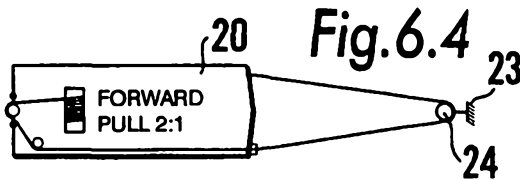

Fig. 6.4

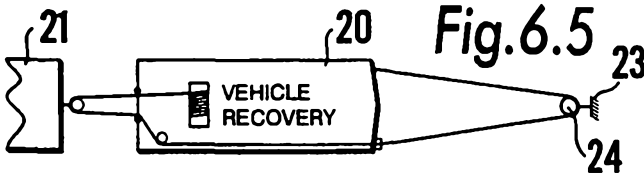

Fig. 6.5

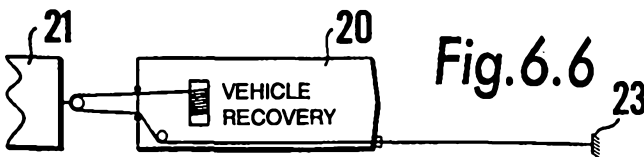

Fig. 6.6

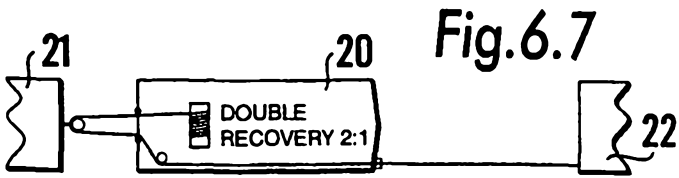

Fig. 6.7

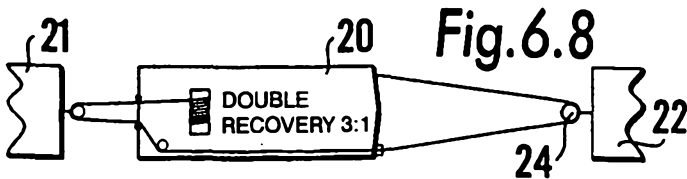

Fig. 6.8



Fig. 6.9

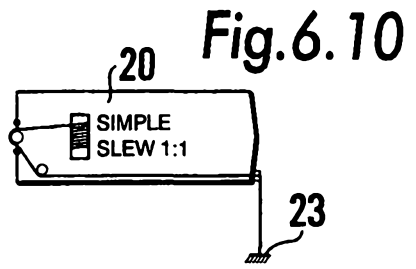

Fig. 6.10

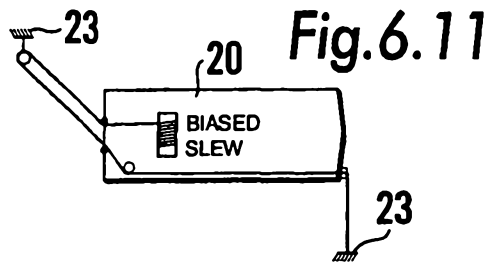

Fig. 6.11

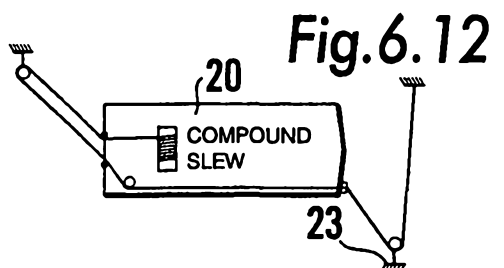

Fig. 6.12

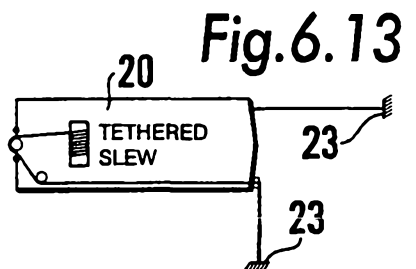

Fig. 6.13

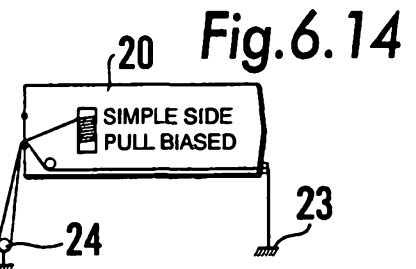

Fig. 6.14

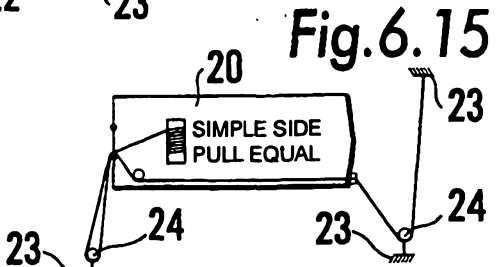

Fig. 6.15