

997,966.

E. W. COOPER.
STEREOTYPE PLATE CLAMP.
APPLICATION FILED JAN. 26, 1909.

Patented July 18, 1911.

2 SHEETS—SHEET 1.

FIG. 1.

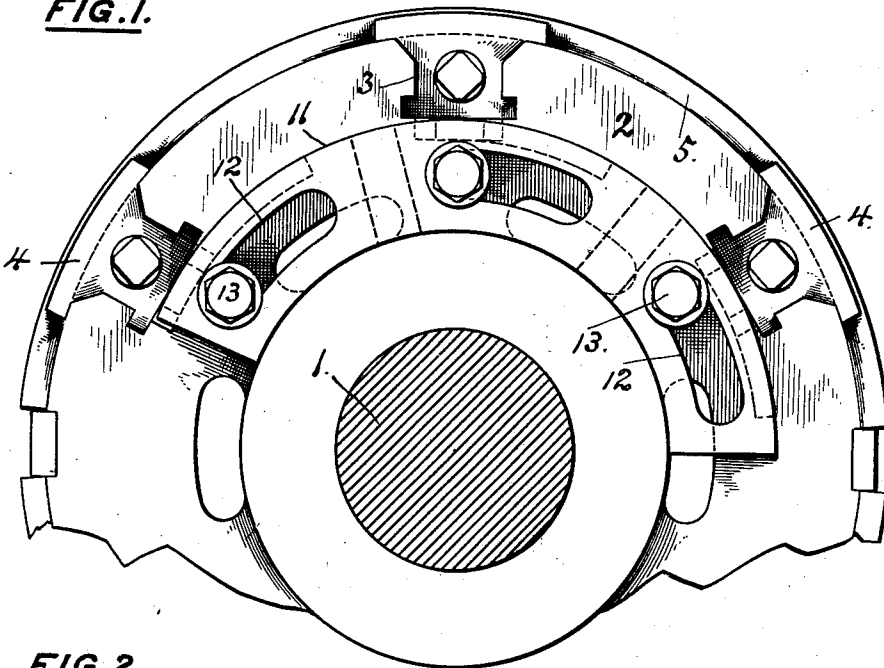
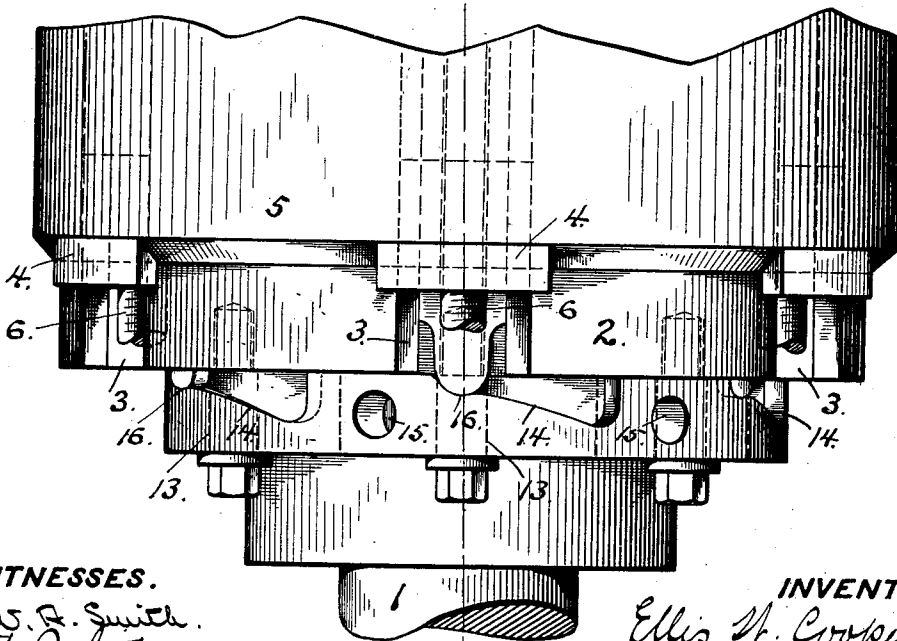

FIG. 2.



WITNESSES.

W. F. Smith.
A. White

INVENTOR.

Ellis H. Cooper
by Phillip Sawyer Rice & Kennedy

ATT'YS.

E. W. COOPER.
 STEREOTYPE PLATE CLAMP.
 APPLICATION FILED JAN. 26, 1909.

997,966.

Patented July 18, 1911.

2 SHEETS—SHEET 2.

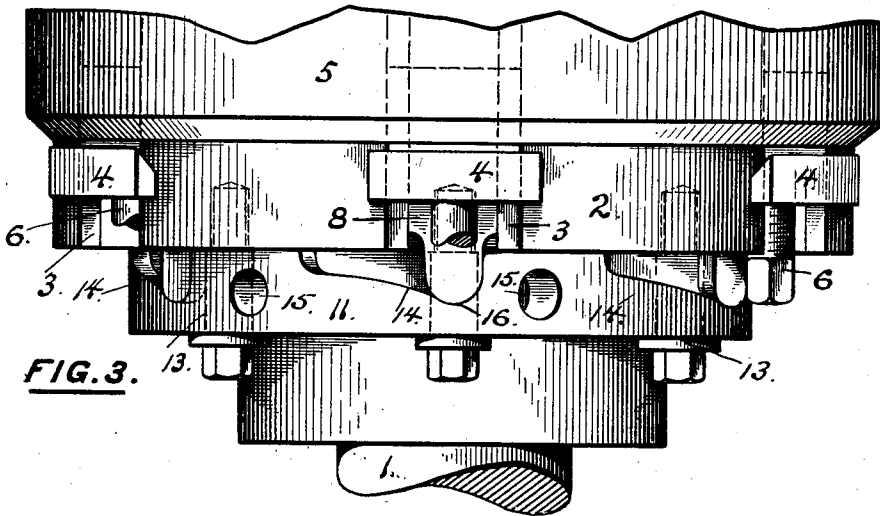

FIG. 3.

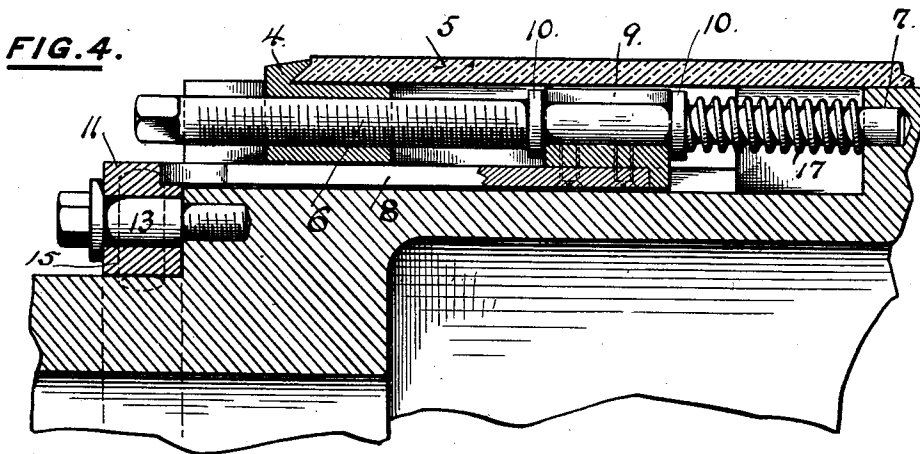
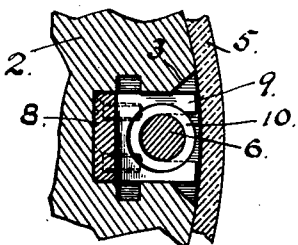

FIG. 4.

FIG. 6.



WITNESSES.

W. F. Smith.
 A. White

FIG. 5.

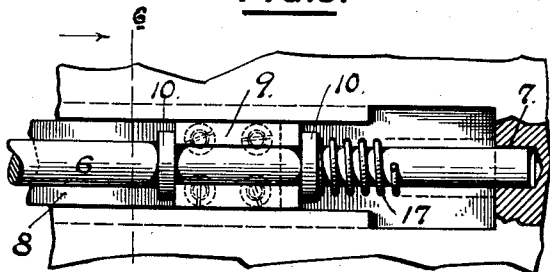

INVENTOR.

Ellis H. Cooper
 by Phillips, Sawyer, Rice & Kennedy
 ATTYS.

UNITED STATES PATENT OFFICE.

ELLIS W. COOPER, OF NEW YORK, N. Y., ASSIGNOR, BY MESNE ASSIGNMENTS, TO R. HOE AND CO., OF NEW YORK, N. Y., A CORPORATION OF NEW YORK.

STEREOTYPE-PLATE CLAMP.

997,966.

Specification of Letters Patent. Patented July 18, 1911.

Application filed January 26, 1909. Serial No. 474,200.

To all whom it may concern:

Be it known that I, ELLIS W. COOPER, a citizen of the United States, residing at New York, county of New York, and State of New York, have invented certain new and useful Improvements in Stereotype-Plate Clamps, fully described and represented in the following specification and the accompanying drawings, forming a part of the same.

This invention relates to certain improvements in stereotype plate clamps.

Stereotype plates are usually secured in place on the plate cylinders by means of clamps or clips which engage the edges of the plates. It is important that the construction by which the clamps are operated should be such as to enable the plate locking operation to be effected quickly and at the same time the construction should be such as to provide for slight variations in the dimensions of the plates, since the trimming devices do not always produce plates in which the clamping surfaces are true. It is also important that the devices for effecting the operation of the clamps should be simple and compact, so as not to unduly extend the length of the cylinder, since any increase in the length of the cylinder increases the widthwise dimensions of the printing machine.

The object of this invention is to produce an improved construction for locking stereotype plates to the plate cylinders of printing machines, which construction shall be simple, cheap to construct, effective in its operation, and which shall require very little space on the cylinder beyond that which is to be occupied by the plates.

With this and other objects not specifically referred to in view, the invention consists in certain constructions and in certain parts, improvements and combinations as will be hereinafter fully described and specifically pointed out.

Referring to the accompanying drawings—Figure 1 is an end elevation of a part of a plate cylinder provided with the improved locking construction. Fig. 2 is a plan view of the construction illustrated in Fig. 1. Fig. 3 is a view similar to Fig. 2 with the parts in a different position. Fig. 4 is a sectional elevation illustrating the construction of one of the plate clamps and its

operating devices. Fig. 5 is a plan view of a part of the construction shown in Fig. 4, the stereotype plate shown in that figure being removed. Fig. 6 is a section on the line 6—6 of Fig. 5.

In the particular embodiment of the invention which has been selected for illustration, 1 indicates the shaft upon which the plate cylinder 2 is mounted. The cylinder is shown as provided with recesses 3 in which the plate clamps 4 which may be of any suitable construction slide. The number of clamps employed may vary according to the dimensions of the stereotype plate, indicated at 5, but in the construction shown, three clamps are employed. It will of course be understood that the opposite end of the cylinder is or may be provided with similar plate clamps.

Constructions embodying the invention will include a plurality of plate clamp carriers, one for each clamp, and the construction will be such that the clamp may be adjusted with respect to the carrier. While the construction of these carriers may be varied, as shown, they consist of threaded rods 6 stepped in sockets 7 formed in the end of the recesses 3. It will be apparent that by turning these threaded rods, the clamps will be advanced toward or away from the edge of the plate. By this construction, each clamp may be independently adjusted with respect to the edge of the plate and all the clamps can, therefore, be so adjusted as to firmly grip the plate, notwithstanding the fact that parts of its edge may be out of true. In addition to the means for thus operating the clamps, constructions embodying the invention will include means for simultaneously operating the clamp carriers to bring the clamps into clamping position, and these means will be arranged to engage the carriers behind the clamps, *i. e.* on that side of the clamps which is toward the center of the cylinder. While the construction of the operating means for simultaneously operating the carriers may be varied, as shown, there is provided a plurality of sliding actuator plates 8, these plates moving in the bottom of the recesses 3 before referred to. These actuator plates 8 are, in the construction illustrated, each provided with a forked block 9, each block being secured to its actuator plate in any

suitable manner, as by screws. These forked blocks 9 engage the carriers 6 between collars 10, so that a movement of the actuator plates produces a corresponding movement of the carriers and their clamps. Constructions embodying the invention will include, as has been indicated, means for simultaneously operating the carriers to bring the clamps against the edge of the plate. While these means may be varied, in the construction shown they include an operating member comprising a segmental plate 11 mounted on the end of the cylinder, this plate being arranged to have a circumferential movement with respect to the cylinder. As shown, the plate 11 is provided with slots 12 through which pass studs 13, these studs being threaded in the end of the cylinder. As illustrated, this segmental plate 11 is provided with a plurality of cam surfaces 14, one for each actuator plate, these cam surfaces being arranged to act directly upon the end of the actuator plates. The segmental plate 11 may further be provided with holes, as 15, in which a suitable bar or pin wrench may be inserted, for the purpose of turning the plate. With the construction as described, it will be noted that all the actuating mechanism for the clamps except the segmental plate 11 can be arranged beneath the plate supporting surface of the cylinder, which makes it possible to utilize practically the entire surface of the cylinders for plate supporting surfaces.

Suitable means may be provided for locking the segmental plate in the position it occupies after it has been moved to adjust the clamps against the printing plate. This may be conveniently effected by providing the cam surfaces 14 which are formed in recesses in the plate 11 with depressions, as 16, in which the ends of the sliding plates 8 are received when the clamps are in locking position.

The carrier rods may be backed up by springs 17 which effect a movement of the carrier rods and actuator plates in a direction opposite to that produced by the segmental plate 11, thus releasing the clamps, when the plate 11 is in unlocked position.

The operation of the construction will be readily understood from the foregoing description.

It will be seen that the locking devices are very simple, require but few parts, and further that the entire surface of the cylinder may be utilized for supporting the stereotype plates, since all the locking mechanism, with the exception of the segmental plate, is located beneath the surface of the cylinder. The plates may therefore extend to the ends of the cylinder. The construction is, furthermore, exceedingly compact and practically requires no extension of the cylinders which will increase the over-all

dimensions of the machine, since the segmental locking plate 11 which is the only part of the construction shown which lies beyond the end of the cylinder, requires but very little room.

Changes and variations may be made in the specific construction by which the invention is carried into effect. The invention is not, therefore, to be confined to the particular construction hereinbefore shown and described.

What is claimed is:—

1. The combination with a plate cylinder, of a plurality of sliding plate clamps, a plurality of clamp carriers one for each clamp, means for adjusting each clamp on its carrier, and positively operating means for simultaneously operating the carriers to bring the clamps into clamping position, said means engaging the carriers behind the clamps.

2. The combination with a plate cylinder, of a plurality of sliding plate clamps, a plurality of clamp carriers one for each clamp, means for adjusting each clamp on its carrier, carrier actuating means engaging the carriers behind the clamps, and an operating member arranged to simultaneously operate the carriers through the actuating means to move the clamps into operative position.

3. The combination with a plate cylinder, of a plurality of sliding plate clamps, a plurality of clamp carriers one for each clamp, means for adjusting each clamp on its carrier, a segmental operating plate movable circumferentially of the cylinder, and actuating means between the segmental plate and the carriers said actuating means being arranged to engage the carriers behind the clamps.

4. The combination with a plate cylinder, of a plurality of sliding plate clamps, a plurality of clamp carriers one for each clamp, means for adjusting each clamp on its carrier, an actuator for positively operating each carrier, and means for simultaneously operating the actuators.

5. The combination with a plate cylinder, of a plurality of sliding plate clamps, a plurality of clamp carriers one for each clamp, means for adjusting each clamp on its carrier a positively operating actuator for each carrier, said actuators engaging the carriers behind the clamps and operating to move the clamps into operative position, and means for simultaneously operating the actuators.

6. The combination with a plate cylinder, of a plurality of sliding plate clamps, a threaded carrier rod for each clamp, a segmental cam plate arranged to move circumferentially with respect to the cylinder, and actuating means engaging the carrier rods behind the clamps.

7. The combination with a plate cylinder,
of a plurality of sliding plate clamps, a
threaded carrier rod for each clamp, a seg-
mental cam plate arranged to move circum-
ferentially with respect to the cylinder, and
a plurality of sliding actuator plates engag-
ing the carrier rods behind the clamps.

In testimony whereof, I have hereunto
set my hand, in the presence of two subscrib-
ing witnesses.

ELLIS W. COOPER.

Witnesses:

F. W. H. CRANE,
LOUIS ROEHM.

Copies of this patent may be obtained for five cents each, by addressing the "Commissioner of Patents,
Washington, D. C."
