

632003

SPRUSON & FERGUSON

AUSTRALIA

PATENTS ACT 1990

PATENT REQUEST: STANDARD PATENT

I/We, the Applicant(s)/Nominated Person(s) specified below, request I/We be granted a patent for the invention disclosed in the accompanying standard complete specification.

[70,71] Applicant(s)/Nominated Person(s):

American Telephone and Telegraph Company, incorporated in New York, of
550 Madison Avenue, New York, New York, 10022, UNITED STATES OF AMERICA

[54] Invention Title:

Message-Oriented Bank Controller Interface

[72] Inventor(s):

Lane Jordan Abrams, Inars Gruntals, Hoo-Yin Khoe, Kevin
Loughran

[74] Address for service in Australia:

Spruson & Ferguson, Patent Attorneys
Level 33 St Martins Tower
31 Market Street
Sydney New South Wales Australia (Code SF)

[31] Appl'n No(s):

603,492

Details of Basic Application(s):

[33] Country:

US

[32] Application Date:

26 October 1990

DATED this TWENTY FIRST day of OCTOBER 1991

American Telephone and Telegraph Company

By:

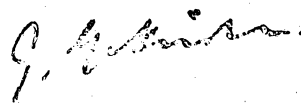

Registered Patent Attorney

IRN: 193757

INSTR CODE: 63845

REPRINT OF RECEIPT

5025132 21/10/91

CORPORATE

SPRUSON & FERGUSON

Australia

Patents Act 1990

NOTICE OF ENTITLEMENT

I, Christopher Malcolm Kelway Watts, of 60, Aldborough Road South, Seven Kings, Ilford, Essex IG3 8EX England
being authorised by the Applicant/Nominated Person in respect of an application entitled:

MESSAGE-ORIENTED BANK CONTROLLER INTERFACE

state the following:-

1. The Applicant/Nominated Person has, for the following reasons, gained entitlement from the actual inventor(s):-

The Applicant is the assignee of the actual inventor(s)

2b. The Applicant/Nominated Person is entitled to rely on the basic application(s) listed on the Patent Request as follows:

The Applicant is the assignee of the basic applicant(s).

3. The basic application(s) listed on the Patent Request is/are the application(s) first made in a Convention Country in respect of the invention.

DATED this 26th day of September 1991

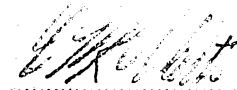

(Signature)

C.M.K. Watts
The Applicant's Attorney

(12) PATENT ABRIDGMENT (11) Document No. AU-B-86019/91
(19) AUSTRALIAN PATENT OFFICE (10) Acceptance No. 632003

- (54) Title
MESSAGE-ORIENTED BANK CONTROLLER INTERFACE
- International Patent Classification(s)
(51)⁵ H04L 012/42
- (21) Application No. : 86019/91 (22) Application Date : 21.10.91
- (30) Priority Data
- (31) Number (32) Date (33) Country
603492 26.10.90 US UNITED STATES OF AMERICA
- (43) Publication Date : 10.04.92
- (44) Publication Date of Accepted Application : 10.12.92
- (71) Applicant(s)
AMERICAN TELEPHONE AND TELEGRAPH COMPANY
- (72) Inventor(s)
LANE JORDAN ABRAMS; INARS GRUNTALS; HOO-YIN KHOE; KEVIN LOUGHRAN
- (74) Attorney or Agent
SPRUSON & FERGUSON, GPO Box 3898, SYDNEY NSW 2001
- (56) Prior Art Documents
US 4590473
- (57) Claim

1. A circuit for transmitting a digital stream and receiving a digital stream including multiple bytes of data and control signals, said circuit

CHARACTERISED BY four registers, a first register (21) being adapted to receive control signals which are part of said received digital stream, a second register (23) being adapted to transmit control signals as part of said transmitted digital stream, a third register (22) being adapted to receive data which is part of said received digital stream, and a fourth register (24) being adapted to transmit data as part of said transmitted digital stream.

6. A digital loop transmission system comprising:

a Bank Controller Unit (10); and

a plurality of peripheral devices (14) which communicate with said Bank Controller Unit,

CHARACTERISED IN THAT each of said peripheral devices includes four registers, a first register (21) being adapted to receive control signals from the Bank Controller Unit, a second register (23) being adapted to transmit control signals to said Bank Controller Unit, a third register (22) being adapted to receive data messages from said Bank Controller Unit, and a fourth register (24) being adapted to transmit data messages to said Bank Controller Unit.

12. A method for transmitting a digital stream comprising control signals and data messages between a Bank Controller Unit (10) and a peripheral device (14) which includes at least four registers (21-25),

CHARACTERIZED IN the steps of:

writing control signals to the peripheral device in a first register (21) and

(11) AU-B-86019/91
(10) 632003

-2-

control signals to the Bank Controller Unit in a second register (23) of the peripheral device; and

writing data messages to the peripheral device in a third register (22) and writing data messages to the Bank Controller Unit in a fourth register (24).

632003

S & F Ref: 193757

AUSTRALIA
PATENTS ACT 1990

COMPLETE SPECIFICATION

FOR A STANDARD PATENT

ORIGINAL

Name and Address
of Applicant: American Telephone and Telegraph Company
550 Madison Avenue
New York New York 10022
UNITED STATES OF AMERICA

Actual Inventor(s): Lane Jordan Abrams, Inars Gruntals, Hoo-Yin Khoe, Kevin
Loughran

Address for Service: Spruson & Ferguson, Patent Attorneys
Level 33 St Martins Tower, 31 Market Street
Sydney, New South Wales, 2000, Australia

Invention Title: Message-Oriented Bank Controller Interface

The following statement is a full description of this invention, including the best method of performing it known to me/us:-

MESSAGE-ORIENTED BANK CONTROLLER INTERFACE

Background of the Invention

This invention relates to message-oriented digital communication, such as that which can be utilized between a Bank Controller Unit and peripheral devices.

5 In present digital loop transmission technology, digital transmission occurs between a central office terminal and a remote terminal, and between a remote terminal and the subscribers. The various units of the remote terminal, such as channel units, are controlled by a Bank Controller Unit which communicates with the various peripheral units through a register-oriented interface.

10 The development of new features in the loop systems, such as automated channel test units (see U.S. Patent 5,018,184), and channel unit inventory control schemes, requires the transfer of large blocks of data (typically tens or hundreds of bytes). Such transfers require protection against errors which may be beyond the capacity of existing Bank Controller link protocols.

15 Message-oriented systems have been proposed for data communications (see, e.g., U.S. Patent 4,562,533). It is desirable to provide a message-oriented system which will transport error-protected messages of arbitrary content and length, and which is compatible with existing Bank Controller Unit protocols.

Summary of the Invention

20 These and other objects are achieved in accordance with the invention, which, in one aspect, is a circuit for transmitting and receiving a digital stream including multiple bytes of data and control signals, where the circuit comprises at least four registers. A first register is adapted to receive control signals which are part of the digital stream, while a second register is adapted to transmit control signals as part of the digital stream. A third register is adapted to receive data which is part of the digital stream, while a fourth register is adapted to transmit data as part of the digital stream. A fifth register may also be included to store data transmitted by the fourth register and to transmit the data in the event of an error in transmitting the data from the fourth register.

30 Brief Description of the Drawing

 These and other features of the invention are delineated in detail in the following description. In the drawing:

 FIG. 1 is a block diagram illustrating a typical link between a Bank Controller Unit and a Bank Peripheral Device;

FIG. 2 is a block diagram illustrating a portion of a peripheral device in accordance with an embodiment of the invention;

FIG. 3 illustrates a typical organization of a data bit stream into a message in accordance with the same embodiment; and

5 FIGS. 4 and 5 illustrate typical formats for data bit streams in accordance with the prior art.

Detailed Description

FIG. 1 is a block diagram illustrating a typical Bank Controller Unit link to peripheral devices in the central office terminal or remote terminal of a digital
10 loop transmission system. The Bank Controller Unit (BCU), 10, includes a microprocessor, 11, which communicates to a Serial Control Link Driver (SCLD), 12, which is usually part of an Alarm and Display Unit (ADU), 13. Communication takes place over a Data/Address (D/A) bus 28. The Serial Control Link Driver, 12, communicates with each Bank Peripheral Device (BPD), such
15 as 14, by means of two sets of leads, designated NP and NQ leads, 15 and 16, respectively, as well as a bidirectional serial data bus 17. One NP lead, one NQ lead and the data bus terminate on a Bank Control Link Terminator, e.g., 18, which is part of each peripheral device's circuitry. The NP and NQ leads jointly select the peripheral device, while the data pass over the data bus in both directions. The
20 terminator includes registers (not shown) which can be accessed by the peripheral device's microprocessor 19.

Each peripheral device, 14, also has a service request (SR) lead, 20, which is coupled directly to the Bank Controller Unit, 10, and which is shared among several peripheral devices. This lead can provide an interrupt function during
25 the normal BCU communication with the peripheral device.

In a register-oriented system, the BCU, 10, would command the SCLD, 12, to send a message typically containing eight bits of data to a specified register of a peripheral device. The SCLD would then send the message to the terminator of the peripheral device, 14, as further illustrated in FIG. 4 along with the
30 waveforms of the NP and NQ leads to that peripheral device. The message consisted of a read/write select bit, 16 message bits and a parity bit. The 16 message bits, as shown, were, typically, divided into an address field ($A_0 - A_7$) that identified the register designated to receive the message, and a data field ($D_0 - D_7$) that contained the data to be written into the register. The peripheral device would send back two
35 check code bits ($C_0 - C_1$) to indicate whether received and calculated parity agreed and whether the register address was valid. A check code value of {1,0} indicated

parity agreement and a valid register address. A value of {0,1} indicated parity disagreement. A value of {0,0} indicated parity agreement but an invalid register address. In order to receive a message from a peripheral device, the Serial Control Link Driver (SCLD), 12, would send a message in the same format, but with the
5 read/write select bit set to "read" and the data field containing all zeros as further illustrated in FIG. 5. The peripheral device would send back two check code bits ($C_0 - C_1$), 16 message bits, and a parity bit (P). Again, the message bits would be divided into an address field ($A_0 - A_7$) that identified the register being read and a data field ($D_0 - D_7$) containing the data in that register. The SCLD would also test
10 for a match between received and calculated parity. After each read and write operation, the BCU would read a register on the SCLD, which register's content would indicate whether the operation was error-free. In the case of an error-free read operation, the BCU would read yet another register in the SCLD, which register would contain the data obtained from the peripheral device. If an error were
15 reported, the BCU would try again. For additional error protection on a read operation, the BCU would compare the address register information in the messages transmitted and received by the SCLD.

In accordance with one feature of the invention, the terminator of each peripheral device is provided with at least four, and preferably five, registers which
20 are dedicated to message-oriented communication with that device, as illustrated in the block diagram of FIG. 2. Each register, 21-25, in this example is 8-bits wide. The register, 21, labeled "SIG_OUT", receives outgoing control signals, while the register, 22, labeled "DATA_OUT" receives outgoing message data. ("Outgoing" refers to communication from the BCU toward the peripheral device, while
25 "Incoming" denotes communication from the peripheral device to the BCU.) Incoming communication is handled by three registers. Register, 23, labeled "SIG_IN" receives control signals from the peripheral device, while register, 24, labeled "DATA_IN1" receives the data messages. The final, optional, register, 25, labeled "DATA_IN2" holds the last byte read by the SCLD from "DATA_IN1". In
30 case there is an error, this byte can then be re-read by the SCLD from this auxiliary register. Control circuitry, 26 and 27, provides several functions including selecting a register, deciding whether the chosen register is to be read or written, determining whether an error has occurred in transmission from the BCU, and notifying the BCU or peripheral device's microprocessor whether a transmission error has occurred.
35 Notifying the BCU of an error in an outgoing message can be accomplished by controlling the value of the check code, previously mentioned.

Whenever the SIG_IN register, 23, contains a control signal value other than IDLE, the peripheral device will assert a service request toward the BCU on the service request lead, 20. This feature enables the BCU to recognize a pending information transfer without periodically polling the SIG_IN registers, which polling would divert a portion of the BCU's processing capacity from other tasks. A signal value of IDLE in the SIG_IN register causes the service request to be retired. In this example, the IDLE value is zero.

In accordance with a feature of the invention, flow control is implemented by using a new value of the check code. Flow control ensures that the BCU does not send or receive data faster than the peripheral device can receive or send the data, respectively. In particular, the BCU should not write a byte into the BPD's DATA_OUT register until the peripheral device's microprocessor (19) has copied the previous byte from DATA_OUT, and the BCU should not read the BPD's DATA_IN1 register while it contains data previously read by the BCU or the DATA_IN2 register while it does not contain current data. In any of these cases, if a register is not ready to be written or read, the check code will indicate that the register is BUSY.

Thus, in the event that the BCU attempts to access any of the data registers (22, 24 or 25) when the register is busy, the terminator will send out a newly designated value of the existing two-bit check code to indicate this fact to the BCU. That is, the newly designated value of (1,1) indicates a good parity, a valid register address, but a busy data register.

FIG. 3 illustrates the message format utilized in accordance with the invention. The message is transferred from the BCU to the peripheral device via the DATA_OUT register, 22, or from the peripheral device to the BCU via the DATA_IN1 and DATA_IN2 registers, 24 and 25, respectively. Each division (with the exception of "Information") indicates one byte of the message. The first two bytes, 31 and 32, labeled "Length (Lower)" and "Length (Upper)" indicate to the receiver the total length of the message, including the length bytes themselves and the Stop and Checksum bytes (40 and 41, respectively). The Length (Lower) byte contains the least significant eight bits of the binary number representing the length. The Length (Upper) byte contains the most significant eight bits of the number representing the length. The Physical Target (Coarse) byte, 33, designates the particular central office or remote terminal to which the message will be sent. The Physical Target (Fine) byte, 34, indicates the particular circuit card in the central office or remote terminal to which the message will be sent. The Firmware Target

(Coarse) byte, 35, designates the broad category of firmware or software which will receive the message (e.g., the firmware which handles inventory control), while the Firmware Target (Fine) byte, 36, indicates the specific function of the destination firmware object (e.g., the function of accepting inventory information from a peripheral device). The Physical Source (Coarse) byte, 37, designates the central office or remote terminal from which the message is transmitted, while the Physical Source (Fine) byte indicates the circuit card within the central office or remote terminal from which the message originates.

The above-described header bytes are followed by the Information bytes, 39, which contain the payload of the message (i.e., the block of data whose transfer is the ultimate purpose of the invention). It is contemplated that the Information portion of the message may have any length from zero to 65,525 bytes, and can have any content, since the data and control signals will be handled by different registers. The Information is followed by a Stop byte, 40, with a fixed value. This byte serves as part of the error detection capability of the system by verifying that the number of bytes received in the message is equal to the number of bytes promised in the Length bytes (31 and 32). The remainder of the error detection capability is provided by the Checksum byte 41. Each bit in the Checksum byte is the exclusive OR function of the corresponding bits in all the bytes previously received in the message starting with Length byte 31 and ending with Stop byte 40. Thus, for example, if the first bits in all of the received bytes contain a total of ones which is odd, the first bit of the Checksum byte will be a one, while if the total is even, the first bit of the Checksum byte will be zero. Similarly, the exclusive OR function will be calculated for each of the other bits in the Checksum byte.

Recognizing the Stop byte, and calculating the checksum require relatively little computing power and memory. Consequently, the combination of Stop and Checksum bytes is particularly useful in digital loop systems since the peripheral devices tend to have small (8-bit) processors and limited memory space (typically less than 256 bytes of RAM and less than 4 Kbytes of ROM). Further, the use of the Stop byte in addition to the Checksum byte is desirable for reducing still further the probability of failing to detect an error in the length bytes.

Table I below indicates in more detail a typical message transfer from the Bank Controller Unit (BCU) to the Bank Peripheral Device (BPD). The first column designates the function performed by the BCU, the second column designates the register employed, and the third column designates the function performed by the BPD. The arrows between columns illustrate the direction of

transfer of the control signal bytes and data bytes. The solid double arrow indicates a service request asserted by the BPD, while the dotted double arrow indicates retiring of a service request.

It will be noted that the BCU first writes a Request to Send (RTS) signal
5 into the SIG_OUT register (see FIG. 2) which is read by the BPD. The BPD then writes a Clear to Send (CTS) signal into the SIG_IN register which is read by the BCU. The Start of Message Out (SMO) signal is then written into the SIG_OUT register by the BCU and read by the BPD. An Idle signal (IDLE) is then sent by the BPD to retire the service request. The BCU then writes the data bytes (31 to 41
10 inclusive in FIG. 3) one byte at a time into the DATA_OUT register, where they are read out one byte at a time by the BPD. If, at any time, the BPD responds to an offered byte with a busy check code, the BCU saves the byte and tries again later. After the last (Checksum) byte is read, the BPD compares the Checksum byte with the checksum that the BPD has calculated as it received the message. Assuming no
15 errors are present, the BPD acknowledges the message to the BCU by writing Message Acknowledge (MACK) in the SIG_IN register. The BCU then indicates the End of Message in the SIG_OUT register, and the BPD retires the service request by writing an Idle signal in the SIG_IN register.

If a BPD is unable to accept a message when the BCU writes RTS into
20 the SIG_OUT register (e.g., if the BPD is busy with other activities), the BPD writes "BPD Busy" (BPD_BSY) into the SIG_IN register. The BCU then writes EOM into SIG_OUT, saves the message, and tries later. The BPD writes IDLE into the SIG_IN register to retire the service request.

TABLE I

	BANK CONTROLLER UNIT (BCU)	REGISTER	BANK PERIPHERAL DEVICE (BPD)
5	Request to Send (RTS) ----->	SIG_OUT	-----> Read Signal Byte
	Read Signal Byte <-----	SIG_IN	<----- Clear to Send (CTS)
10	Start of Message Out (SMO) ----->	SIG_OUT	-----> Read Signal Byte
	Ignore <-----	SIG_IN	<----- Idle (IDLE)
	First Data Byte (Length - Lower) ----->	DATA_OUT	-----> Read Data Byte
15	Second Data Byte (Length - Upper) ----->	DATA_OUT	-----> Read Data Byte
	o o		o o
	o o		o o
	Subsequent Data Bytes ----->	DATA_OUT	-----> Read Data Byte
20	o o		o o
	o o		o o
	Next-to-Last Data Byte (Stop) ----->	DATA_OUT	-----> Read Data Byte
25	Last Data Byte (Checksum) ----->	DATA_OUT	-----> Read Data Byte Compare Checksums
	Read Signal Byte <-----	SIG_IN	<----- Message Acknowledge (MACK)
	End of Message (EOM) ----->	SIG_OUT	-----> Read Signal Byte
30	No Action <-----	SIG_IN	<----- Idle (IDLE)

Table II illustrates a typical message transfer from the BPD to the BCU. The BPD begins by writing the first data byte into both the DATA_IN1 and DATA_IN2 registers. The BPD then writes a Request to Send signal into the SIG_IN register where it is read by the BCU. The BCU responds by writing a Start of Message In signal into the SIG_OUT register which is read by the BPD. An Idle signal is then sent by the BPD to retire the service request. The BCU then reads the first Data byte which was previously written into the DATA_IN1 register. Subsequently, the BPD writes the remainder of the Data bytes, one byte at a time, into the DATA_IN1 register. As soon as the BCU attempts to read a new byte from DATA_IN1, the BPD will copy the new byte into DATA_IN2. The BCU reads the Data bytes from DATA_IN1 as they are written therein, and, if an error is detected, will re-read a byte from DATA_IN2. If a Data byte in DATA_IN2 is not read, it will merely be replaced by the next byte. After reading the last byte, the BCU will compare the Checksum byte with the checksum that the BCU has calculated as it received the message, and, if there is agreement, send a message acknowledgment by writing Message Acknowledge (MACK) into the SIG_OUT register.

TABLE II

	BANK CONTROLLER UNIT (BCU)	REGISTER	BANK PERIPHERAL DEVICE (BPD)
5			
		DATA_IN1	First Data Byte (Length - Lower)
		DATA_IN2	First Data Byte
	Read Signal Byte	SIG_IN	Request to Send (RTS)
10	Start of Message In (SMI)	SIG_OUT	Read Signal Byte
	Ignore	SIG_IN	Idle (IDLE)
	Read Data Byte		
	Read (if error)		
15	Read Data Byte	DATA_IN1	Second Data Byte (Length - Upper)
	Read (if error)	DATA_IN2	Second Data Byte
	Read	DATA_IN1	Third Data Byte
	o	o	o
20	o	o	o
	Read Data Byte	DATA_IN1	Subsequent Data Bytes
	o	o	o
	o	o	o
25	Read Data Byte	DATA_IN1	Next-to-Last Data Byte (Stop)
	Read (if error)	DATA_IN2	Next-to-Last Data Byte
	Read Data Byte	DATA_IN1	Last Data Byte (Checksum)
	Read (if error)	DATA_IN2	Last Data Byte
30	Compare Checksums		
	Message Acknowledge (MACK)	SIG_OUT	Read Signal Byte

It will be appreciated that this byte transfer protocol permits a message of any length from 10 to 65,535 bytes containing from zero to 65,525 Information bytes, and in no way restricts the content of an Information byte.

At any time during message transfer, either the BCU or BPD can abort
5 by issuing an appropriate signal, i.e., the sender can issue an End of Message (EOM) signal or the receiver can issue a Message Transmit Abort (MTA) signal.

If the receiver of a message detects a wrong value in the STOP byte, or finds a checksum disagreement, the receiver sends a "Message Transmission Error" (MTE) signal to the sender via the SIG_IN or SIG_OUT register, as appropriate.

10 The sender may then re-transmit the message.

Various modifications of the invention will become apparent to those skilled in the art. For example, although a Bank Controller link to peripheral devices has been described, the invention could be used for other types of metallic distribution control links.

15

The claims defining the invention are as follows:

1. A circuit for transmitting a digital stream and receiving a digital stream, including multiple bytes of data and control signals, said circuit

each digital stream
CHARACTERISED BY four registers, a first register (21) being
5 adapted to receive control signals which are part of said received digital stream, a second register (23) being adapted to transmit control signals as part of said transmitted digital stream, a third register (22) being adapted to receive data which is part of said received digital stream, and a fourth register (24) being adapted to transmit data as part of said transmitted digital stream.

10 2. The circuit according to claim 1 further comprising a fifth register (25) being adapted to store data transmitted by said fourth register and to transmit said data in the event of an error in transmitting the data from the fourth register.

3. The circuit according to claim 1 wherein the circuit is adapted to respectively transmit and receive said digital streams to and from a Bank Controller
15 Unit (10).

4. The circuit according to claim 3, wherein the circuit is part of a Bank Peripheral Device (14).

5. The circuit according to claim 1 further comprising a microprocessor (19) coupled to the registers.

20 6. A digital loop transmission system comprising:
a Bank Controller Unit (10); and
a plurality of peripheral devices (14) which communicate with said Bank Controller Unit,

CHARACTERISED IN THAT each of said peripheral devices includes
25 four registers, a first register (21) being adapted to receive control signals from the Bank Controller Unit, a second register (23) being adapted to transmit control signals to said Bank Controller Unit, a third register (22) being adapted to receive data messages from said Bank Controller Unit, and a fourth register (24) being adapted to transmit data messages to said Bank Controller Unit.



7. The circuit according to claim 6 further comprising a fifth register (25) adapted to store data messages transmitted by said fourth register and to transmit said data messages in the event of an error in transmitting the data from the fourth register.

5 8. The system according to claim 6 wherein the peripheral devices are channel units.

9. The system according to claim 6 wherein the data messages have a byte length within the range 10-65,535.

10 10. The system according to claim 6 further comprising means (20) for asserting a service request to the Bank Controller Unit when an appropriate signal is in the second register.

11. The system according to claim 6 further comprising means for sending to the Bank Controller Unit a predetermined two-bit signal indicating when one of the registers is busy.

15 12. A method for transmitting a digital stream comprising control signals and data messages between a Bank Controller Unit (10) and a peripheral device (14) which includes at least four registers (21-25),

CHARACTERIZED IN the steps of:

20 writing control signals to the peripheral device in a first register (21) and control signals to the Bank Controller Unit in a second register (23) of the peripheral device; and

 writing data messages to the peripheral device in a third register (22) and writing data messages to the Bank Controller Unit in a fourth register (24).

25 13. The method according to claim 12 further comprising writing the same data messages to the Bank Controller Unit in a fifth register (25) to permit the Bank Controller Unit to read the messages in the event of an error in transmission from the fourth register.

14. The method according to claim 12 wherein the data messages comprise a plurality of header bytes (31-38), a plurality of Information bytes (39), a

Stop byte (40), and a Checksum byte (41), the Checksum byte comprising bits which are the exclusive OR function of all corresponding bits in the previous bytes of the data message.

15 15. The method according to claim 14 wherein the data messages
5 comprise 10-65,535 bytes.

16. The method according to claim 14 wherein the header bytes include two bytes (31, 32) indicating the length of the message, two bytes (33, 34) indicating the physical target of the message, two bytes (35, 36) indicating the firmware target of the message, and two bytes (37, 38) indicating the physical source of the message.

10 17. The method according to claim 12 further comprising asserting a
service request from a peripheral device to the Bank Controller Unit when an
appropriate signal is present in the second register.

15 18. The method according to claim 12 further comprising transmitting
from a peripheral device to the Bank Controller Unit a predetermined two-bit signal
15 indicating when the registers being accessed are busy.

DATED this EIGHTEENTH day of OCTOBER 1991
American Telephone and Telegraph Company

Patent Attorneys for the Applicant
SPRUSON & FERGUSON

FIG. 1
(PRIOR ART)

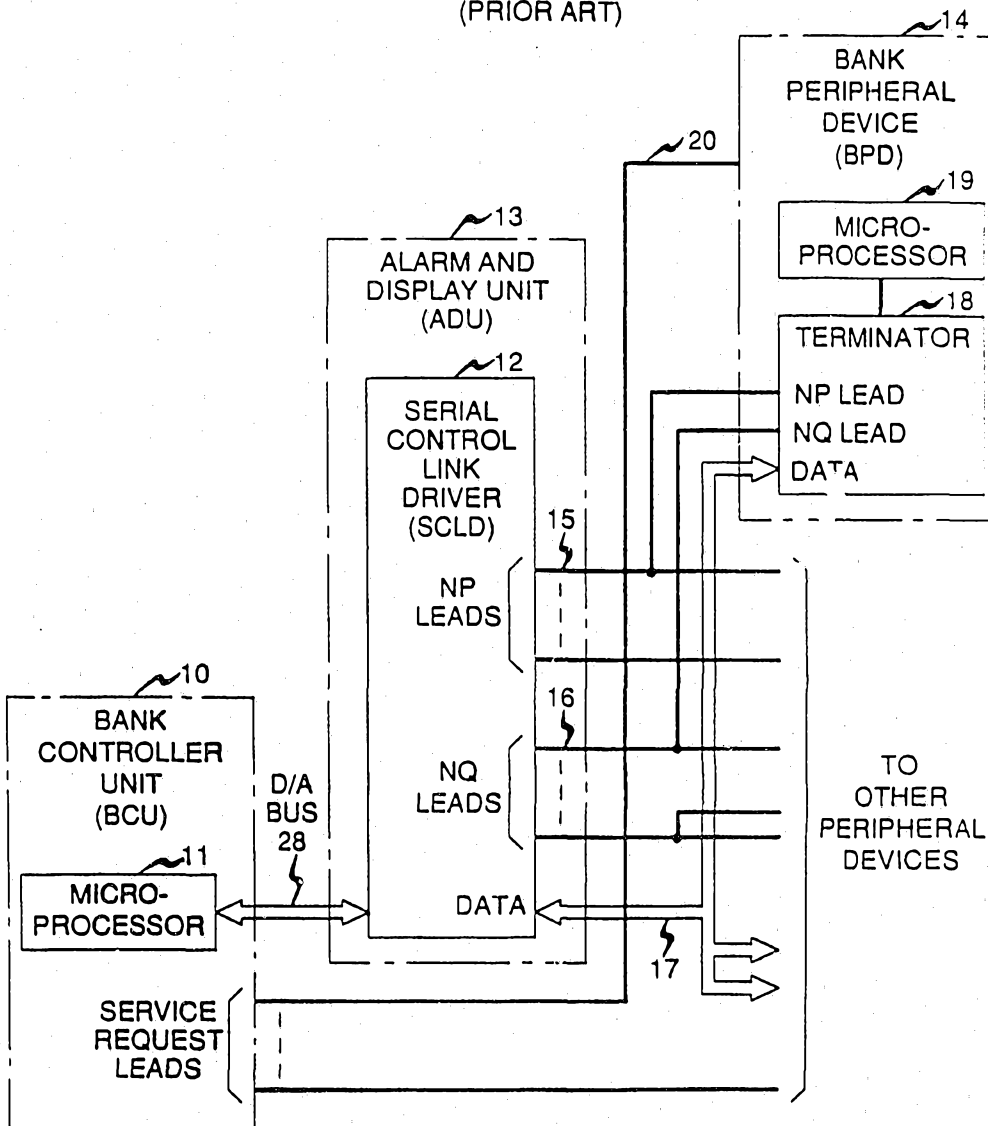
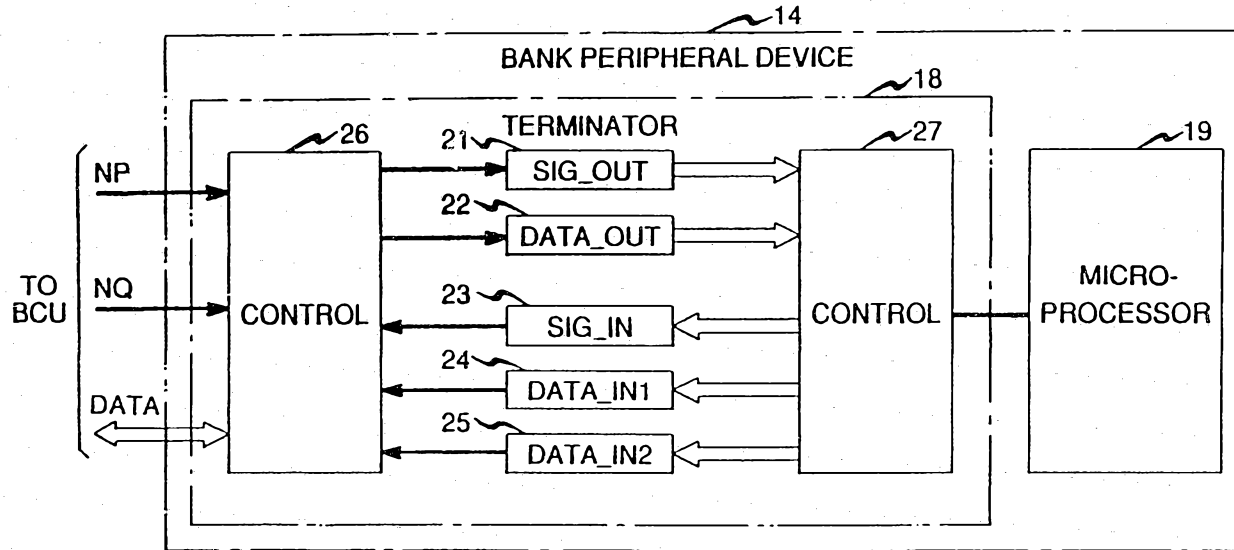

FIG. 2



2/3

FIG. 3

31	32	33	34	35	36	37	38	39	40	41
LENGTH (LOWER)	LENGTH (UPPER)	PHYSICAL TARGET (COARSE)	PHYSICAL TARGET (FINE)	FIRMWARE TARGET (COARSE)	FIRMWARE TARGET (FINE)	PHYSICAL SOURCE (COARSE)	PHYSICAL SOURCE (FINE)	INFORMATION	STOP	CHECK SUM

86019/91

1109 0000

FIG. 4
(PRIOR ART)

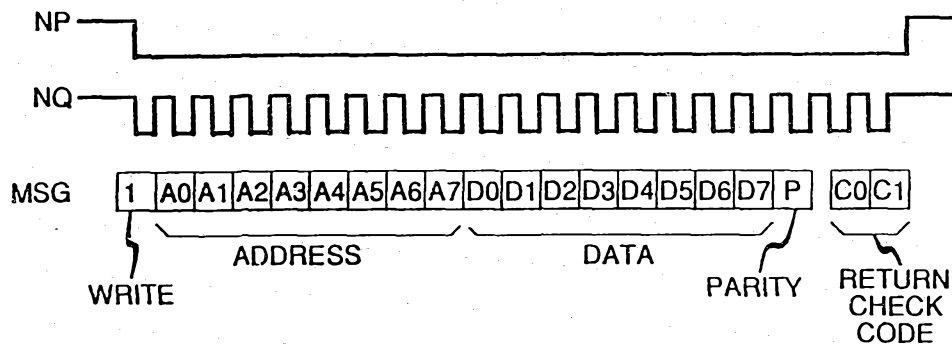

3/3

FIG. 5
(PRIOR ART)

