

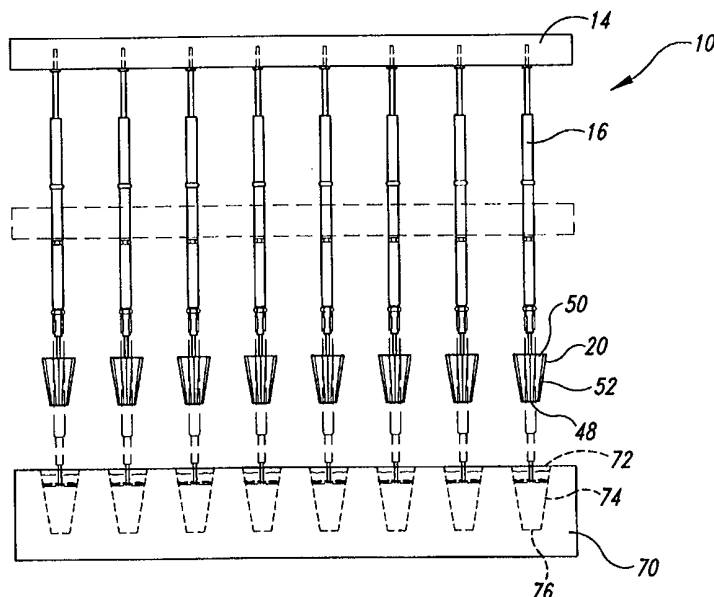

INTERNATIONAL APPLICATION PUBLISHED UNDER THE PATENT COOPERATION TREATY (PCT)

<p>(51) International Patent Classification⁶ : G01N 33/543, 33/53, C12Q 1/68, B01J 19/00</p>	<p>A1</p>	<p>(11) International Publication Number: WO 99/34214</p> <p>(43) International Publication Date: 8 July 1999 (08.07.99)</p>
<p>(21) International Application Number: PCT/US98/27850</p> <p>(22) International Filing Date: 30 December 1998 (30.12.98)</p> <p>(30) Priority Data: 60/070,290 31 December 1997 (31.12.97) US</p> <p>(71) Applicant (for all designated States except US): RAPIGENE, INC. [US/US]; 1631 - 220th Street S.E., Bothell, WA 98021 (US).</p> <p>(72) Inventors; and (75) Inventors/Applicants (for US only): GARRISON, Lori, K. [US/US]; 4515 Evanston Avenue North, Seattle, WA 98103 (US). TABONE, John, C. [US/US]; 12117 Northeast 166th Place, Bothell, WA 98011 (US). VAN NESS, Jeffrey [US/US]; 10020 49th Avenue Northeast, Seattle, WA 98125 (US).</p> <p>(74) Agents: PARKER, David, W. et al.; Seed and Berry LLP, 6300 Columbia Center, 701 Fifth Avenue, Seattle, WA 98104-7092 (US).</p>		<p>(81) Designated States: AL, AM, AT, AU, AZ, BA, BB, BG, BR, BY, CA, CH, CN, CU, CZ, DE, DK, EE, ES, FI, GB, GE, GH, GM, HR, HU, ID, IL, IN, IS, JP, KE, KG, KP, KR, KZ, LC, LK, LR, LS, LT, LU, LV, MD, MG, MK, MN, MW, MX, NO, NZ, PL, PT, RO, RU, SD, SE, SG, SI, SK, SL, TJ, TM, TR, TT, UA, UG, US, UZ, VN, YU, ZW, ARIPO patent (GH, GM, KE, LS, MW, SD, SZ, UG, ZW), Eurasian patent (AM, AZ, BY, KG, KZ, MD, RU, TJ, TM), European patent (AT, BE, CH, CY, DE, DK, ES, FI, FR, GB, GR, IE, IT, LU, MC, NL, PT, SE), OAPI patent (BF, BJ, CF, CG, CI, CM, GA, GN, GW, ML, MR, NE, SN, TD, TG).</p> <p>Published With international search report. Before the expiration of the time limit for amending the claims and to be republished in the event of the receipt of amendments.</p>

(54) Title: SOLID-PHASE TIPS AND USES RELATING THERETO



(57) Abstract

Solid-phase assays have provided a powerful approach to the analysis of biomolecules in medical diagnosis and in basic research. Solid-phase nucleic acid hybridization methods, for example, have been applied to analysis of genetic polymorphisms, diagnosis of genetic disease, cancer diagnosis, detection of viral and microbial pathogens, screening of clones, and ordering of genomic fragments. A new solid-phase sample-retaining tip provides improved procedures for synthesizing or detecting a biomolecule. These tips can be used to devise sample-retaining assemblies, which in turn, can be combined to form arrays of solid-phase sample-retaining assemblies useful in automated processes. The tips may be connectable to a spring biased support pin and also contain a chemical layer coating said tip to which a biomolecule is bindable.

FOR THE PURPOSES OF INFORMATION ONLY

Codes used to identify States party to the PCT on the front pages of pamphlets publishing international applications under the PCT.

AL	Albania	ES	Spain	LS	Lesotho	SI	Slovenia
AM	Armenia	FI	Finland	LT	Lithuania	SK	Slovakia
AT	Austria	FR	France	LU	Luxembourg	SN	Senegal
AU	Australia	GA	Gabon	LV	Latvia	SZ	Swaziland
AZ	Azerbaijan	GB	United Kingdom	MC	Monaco	TD	Chad
BA	Bosnia and Herzegovina	GE	Georgia	MD	Republic of Moldova	TG	Togo
BB	Barbados	GH	Ghana	MG	Madagascar	TJ	Tajikistan
BE	Belgium	GN	Guinea	MK	The former Yugoslav Republic of Macedonia	TM	Turkmenistan
BF	Burkina Faso	GR	Greece	ML	Mali	TR	Turkey
BG	Bulgaria	HU	Hungary	MN	Mongolia	TT	Trinidad and Tobago
BJ	Benin	IE	Ireland	MR	Mauritania	UA	Ukraine
BR	Brazil	IL	Israel	MW	Malawi	UG	Uganda
BY	Belarus	IS	Iceland	MX	Mexico	US	United States of America
CA	Canada	IT	Italy	NE	Niger	UZ	Uzbekistan
CF	Central African Republic	JP	Japan	NL	Netherlands	VN	Viet Nam
CG	Congo	KE	Kenya	NO	Norway	YU	Yugoslavia
CH	Switzerland	KG	Kyrgyzstan	NZ	New Zealand	ZW	Zimbabwe
CI	Côte d'Ivoire	KP	Democratic People's Republic of Korea	PL	Poland		
CM	Cameroon	KR	Republic of Korea	PT	Portugal		
CN	China	KZ	Kazakstan	RO	Romania		
CU	Cuba	LC	Saint Lucia	RU	Russian Federation		
CZ	Czech Republic	LI	Liechtenstein	SD	Sudan		
DE	Germany	LK	Sri Lanka	SE	Sweden		
DK	Denmark	LR	Liberia	SG	Singapore		
EE	Estonia						

SOLID-PHASE TIPS AND USES RELATING THERETO

TECHNICAL FIELD

The present invention relates generally to the application of solid-phase techniques to synthesize and to analyze nucleic acid molecules. In particular, the present invention relates to improved solid-phase supports that can be used to perform a variety of bimolecular procedures.

BACKGROUND OF THE INVENTION

Nucleic acid hybridization provides specificity for the recognition of biomolecules, such as DNA and RNA sequences, and has become a powerful technique in medical diagnosis. For example, nucleic acid hybridization methods have been applied to analysis of genetic polymorphisms, diagnosis of genetic disease, cancer diagnosis, detection of viral and microbial pathogens, screening of clones, and ordering of genomic fragments (for a review, see Chetverin and Kramer, *Bio/Technology* 12:1093, 1994). The development of automated synthesis of oligonucleotide probes has also promoted the development of rapid, simple and inexpensive diagnostic assays based on nucleic acid hybridization. The use of DNA probes in analytical techniques has been reviewed by Matthews and Kricka, *Anal. Biochem.* 169:1, 1988 (also see, Keller and Mank (eds.), *DNA Probes, 2nd Edition* (Stockton Press 1993), Persing et al., *Diagnostic Molecular Microbiology* (American Society for Microbiology 1993)).

A general approach to nucleic acid hybridization requires immobilization of target nucleic acid on solid supports, such as nitrocellulose filters and nylon membranes, followed by hybridization with a detectable nucleic acid probe. The disadvantage of such methods is that the immobilized nucleic acid typically is not tightly bound, resulting in loss of target material from the support. Moreover, only a small amount of nucleic acid molecules are available for hybridization.

These problems can be overcome by a "sandwich-type" hybridization assay in which target nucleic acid is hybridized to a "capture" oligonucleotide that has been covalently immobilized to a solid support. A detectably-labeled probe is then

hybridized with a different region of the captured target nucleic acid, and the presence of the probe is measured.

The discovery of new therapeutic targets and diagnostic markers has been enhanced by techniques for analyzing gene expression patterns derived from large expressed sequence tag databases (Fannon, *Trends Biotechnol.*, 14:294, 1996). Such
5 sequence data, derived from a wide variety of cDNA libraries, offer a wealth of information for identifying genes for pharmaceutical product development. Comparison of expression patterns from normal and disease tissues also provides inferences about gene function, and identifies medically relevant genes as candidates
10 for therapeutics research and development programs.

A significant barrier to a more widespread use of solid-phase cDNA synthesis and the use of DNA probes in simple assays has been the lack of solid supports and immobilization methods that are fully compatible with the hybridization process. The use of solid supports in DNA probe-based hybridization has been
15 reviewed by Meinkoth and Wahl, *Anal. Biochem.* 138:267, 1984.

Poly(ethyleneimine) ("PEI") coatings have been extensively used in the art for binding biomolecules. PEI is very effective in this capacity for a variety of reasons. For instance, PEI is very hydrophilic and thus readily wets aqueous solutions containing biomolecules. In addition, PEI contains many amino groups, which can
20 form salts with acidic groups in a biomolecule. However, the readiness with which PEI accepts aqueous solutions of biomolecules is precisely why it has not, to date, seen use in the preparation of biomolecular arrays. When aqueous biomolecular solutions are placed on a layer of PEI, the solution rapidly wicks throughout the PEI coating rather than staying in a discrete location.

Spring probes have become generally well known since they were
25 introduced early in the development of the printed circuit board industry. They are mechanical devices designed to meet the need for precision and reliability in the construction and testing of a variety of electronic components and their connections when being assembled into functioning circuit boards. Spring probes are essentially
30 electro-mechanical devices, typically consisting of a tubular housing encasing a

compression spring, ball and plunger. Some probes are specifically designed to carry electrical current flow, while others are used to drill, crimp, and secure components to a circuit board, and yet others are designed to perform soldering. There is nothing in the design or marketing of spring probes that suggests their potential utility as a mechanical
5 devise for the transferring and arraying of solutions onto solid support for use in the fields of microbiology, biochemistry, or molecular biology.

Accordingly, a need exists for highly-efficient, cost-effective means for arraying biomolecules on a solid support. The present invention provides these and related advantages as disclosed in more detail herein.

10 SUMMARY OF THE INVENTION

The present invention provides a solid-phase sample-retaining assembly that overcomes the drawbacks experienced by the prior art and provides further related advantages.

In one embodiment of this invention, a solid-phase sample-retaining tip
15 is provided that is usable in a procedure in synthesizing or detecting a biomolecule. The sample-retaining tip includes a solid support tip structure that is connectable to a support pin, and a chemical layer coats at least a portion of the tip structure. The chemical layer is bindable to the biomolecule to form a solid-phase sample of the biomolecule on the tip structure. In one embodiment, the tip structure is removably
20 connected to the support pin. The tip structure has a partially conical shape with a plurality of flutes formed therein. These flutes define a plurality of heat exchange fins that enable the tip structure to quickly heat up and cool down during selected thermocycling procedures in the synthesizing or detecting of biomolecules.

In another embodiment of the invention, a sample-retaining assembly is
25 provided for use in a solid-phase procedure for synthesizing or detecting a biomolecule. The sample-retaining assembly includes a support pin, a tip structure connected to the support pin, and a chemical layer coating at least a portion of the tip structure. The chemical layer is bindable to the biomolecule so as to form a solid-phase sample of the biomolecule on the tip structure. In one embodiment, the support pin is a spring probe

or other spring pin, and the tip structure is a nylon 6/6 member that is removably connected to the spring probe.

In another embodiment of the invention, an array of solid-phase sample-retaining assemblies are provided, wherein a plurality of support pins are connected to a
5 base in a selected array. Each support pin has an end portion that is spaced apart from the base and a plurality of tip structures are connected to the end portions. The chemical layer coats at least a portion of each tip structure. The chemical layer is bindable to a biomolecule to form a solid-phase sample of the biomolecule.

In another embodiment of the invention, a solid-phase sample-retaining
10 assembly is combined with a microtiter plate. The microtiter plate has a well that is shaped to contain a volume of a sample having a biomolecule therein. The solid-phase sample-retaining assembly is sized to extend at least partially into the well. The solid-phase retaining assembly includes a support pin, a tip structure connected to the support pin with the tip structure being removably positionable in the well, and a chemical layer
15 coating at least a portion of the tip structure. The chemical layer is bindable to the biomolecule and the solution to form a solid-phase sample of the biomolecule.

In one embodiment of the invention, the microtiter plate has a plurality of wells therein and the solid-phase sample-retaining assembly includes a plurality of support pins arranged in a selected array, and a plurality of the tip structures are
20 connected to the support pins to form an array of solid-phase sample-retaining tips that are positionable into the plurality of wells.

In another aspect of the invention, solid-phase sample-retaining tips are combined with a microtiter plate having a plurality of wells therein. The solid-phase sample-retaining tips are removably positioned within the microtiter plate's wells. The
25 microtiter plate and the sample-retaining tips are storable as a unit such that a solid-phase sample on the sample-retaining tip can be easily stored until needed for a synthesizing or analyzing procedure.

Another aspect of the invention provides a method of manufacturing the solid-phase sample-retaining tip for use in a solid-phase molecular biology process.
30 The method includes the steps of forming a substrate material as a tip structure that is

attachable to a support pin, coating at least a portion of the substrate material with a chemical layer that is bondable to selected biomolecules to form a solid-phase sample of the biomolecule, and attaching the chemical layer to the substrate. In one embodiment, the chemical layer is a poly(ethyleneimine) and the substrate material is a nylon 6/6 material, and the step of attaching the chemical layer to the substrate material includes covalently attaching the poly(ethyleneimine) to the nylon 6/6 material.

Another embodiment of the invention is directed toward a method of forming a solid-phase sample of a biomolecule. The method includes the steps of immersing a portion of a tip assembly into a solution having a biomolecule therein. The tip assembly has a substrate portion and a chemical layer on the substrate portion, with the chemical layer being bindable to the biomolecule. The biomolecule is allowed to bind to the chemical layer to form a solid-phase sample of the biomolecule on the tip assembly, and the tip assembly is removed from the solution after the biomolecule has bonded to the chemical layer.

In another aspect of the invention, the method includes the step of storing the solid-phase tip assembly in a retaining member after a biomolecule has bonded to the chemical layer. The retaining member in one embodiment of the invention is a microtiter plate with a well therein. The step of storing includes placing the tip assembly in the well after the biomolecule has bonded to the chemical layer, and placing the microtiter plate and tip assembly as a unit in a storage location.

BRIEF DESCRIPTION OF THE DRAWINGS

Figure 1 is an isometric view of an array of solid-phase sample-retaining assemblies in accordance with the exemplary embodiment of the present invention.

Figure 2A is an enlarged cross-sectional view of a solid-phase sample-retaining assembly taken substantially along line 2-2 of Figure 1.

Figure 2B is a cross-sectional view of a solid-phase sample-retaining assembly of an alternate embodiment.

Figure 3 is an enlarged partially cut away view of a tip structure of a sample-retaining assembly of Figure 1.

Figure 4 is an enlarged cross-sectional view of the tip structure taken substantially along line 4-4 of Figure 3.

Figure 5 is a side elevational view of the array of Figure 1 shown in solid lines positioned above a microtiter plate with a plurality of wells with liquid biomolecule samples therein, and shown in phantom lines in lowered position with the tip structures positioned within the wells.

Figure 6 is an enlarged side elevation view of the array of Figure 1 shown with a plurality of the tip structure positioned in the wells of a microtiter plate.

These and other aspects of the present invention will become evident upon reference to the following detailed description and attached drawings. In addition, various references are identified below and are incorporated by reference in their entirety.

DETAILED DESCRIPTION OF THE INVENTION

1. Definitions

In the description that follows, a number of terms are used extensively. The following definitions are provided to facilitate understanding of the invention.

A "structural gene" is a nucleotide sequence that is transcribed into messenger RNA (mRNA), which is then translated into a sequence of amino acids characteristic of a specific polypeptide.

As used herein, "nucleic acid" or "nucleic acid molecule" refers to any of deoxyribonucleic acid (DNA), ribonucleic acid (RNA), oligonucleotides, fragments generated by the polymerase chain reaction (PCR), and fragments generated by any of ligation, scission, endonuclease action, and exonuclease action. Nucleic acids can be composed of monomers that are naturally-occurring nucleotides (such as deoxyribonucleotides and ribonucleotides), or analogs of naturally-occurring nucleotides (*e.g.*, α -enantiomeric forms of naturally-occurring nucleotides), or a combination of both. Modified nucleotides can have modifications in sugar moieties and/or in pyrimidine or purine base moieties. Sugar modifications include, for example, replacement of one or more hydroxyl groups with halogens, alkyl groups,

amines, and azido groups, or sugars can be functionalized as ethers or esters. Moreover, the entire sugar moiety can be replaced with sterically and electronically similar structures, such as aza-sugars and carbocyclic sugar analogs. Examples of modifications in a base moiety include alkylated purines and pyrimidines, acylated purines or pyrimidines, or other well-known heterocyclic substitutes. Nucleic acid monomers can be linked by phosphodiester bonds or analogs of such linkages. Analogs of phosphodiester linkages include phosphorothioate, phosphorodithioate, phosphoroselenoate, phosphorodiselenoate, phosphoroanilothioate, phosphoranilidate, phosphoramidate, and the like. The term "nucleic acid" also includes so-called "peptide nucleic acids," which comprise naturally-occurring or modified nucleic acid bases attached to a polyamide backbone. Nucleic acids can be either single stranded or double stranded.

An "isolated nucleic acid molecule" is a nucleic acid molecule that is not integrated in the genomic DNA of an organism. For example, a DNA molecule that encodes interleukin-2 that has been separated from the genomic DNA of a mammalian cell is an isolated DNA molecule. Another example of an isolated nucleic acid molecule is a chemically-synthesized nucleic acid molecule that is not integrated in the genome of an organism.

In the present context, the term "biomolecule" refers either to a nucleic acid molecule, or to a polymer of amino acids or amino acid analogs.

As used herein, a "detectable tag" or "detectable label" is a molecule or atom which is conjugated to a nucleic acid molecule to produce a probe that is useful for detection methods. Examples of such tags or labels include photoactive agents or dyes, radioisotopes, fluorescent agents, mass spectrometer tags, or other molecules and marker moieties. Suitable fluorescent labeling compounds include fluorescein isothiocyanate, rhodamine, phycoerytherin, phycocyanin, allophycocyanin, o-phthaldehyde and fluorescamine. Examples of chemiluminescent labeling compounds include luminol, isoluminol, an aromatic acridinium ester, an imidazole, an acridinium salt and an oxalate ester. Bioluminescent compounds that are useful for such tags include luciferin, luciferase and aequorin.

“Complementary DNA (cDNA)” is a single-stranded DNA molecule that is formed from an mRNA template by the enzyme reverse transcriptase. Typically, a primer complementary to portions of mRNA is employed for the initiation of reverse transcription. Those skilled in the art also use the term "cDNA" to refer to a double-stranded DNA molecule consisting of such a single-stranded DNA molecule and its complementary DNA strand.

The term “expression” refers to the biosynthesis of a gene product. For example, in the case of a structural gene, expression involves transcription of the structural gene into mRNA and the translation of mRNA into one or more polypeptides.

10 A “cloning vector” is a nucleic acid molecule, such as a plasmid, cosmid, or bacteriophage, that has the capability of replicating autonomously in a host cell. Cloning vectors typically contain one or a small number of restriction endonuclease recognition sites at which foreign nucleotide sequences can be inserted in a determinable fashion without loss of an essential biological function of the vector, as well as nucleotide sequences encoding a marker gene that is suitable for use in the identification and selection of cells transformed with the cloning vector. Marker genes typically include genes that provide tetracycline resistance or ampicillin resistance.

20 An “expression vector” is a nucleic acid molecule encoding a gene that is expressed in a host cell. Typically, gene expression is placed under the control of a promoter, and optionally, under the control of at least one regulatory element. Such a gene is said to be "operably linked to" the promoter. Similarly, a regulatory element and a promoter are operably linked if the regulatory element modulates the activity of the promoter.

25 A “recombinant host” may be any prokaryotic or eukaryotic cell that contains either a cloning vector or expression vector. This term also includes those prokaryotic or eukaryotic cells that have been genetically engineered to contain the cloned gene(s) in the chromosome or genome of the host cell.

30 As used herein, “hybotrope” refers to any chemical or any mixture of a chemical in an aqueous or organic environment with buffers, chelators, salts and/or detergents that changes the enthalpy of a nucleic acid duplex by at least 20% when

referenced to a standard salt solution (0.165 M NaCl, 0.01 M Tris pH 7.2, 5 mM EDTA and 0.1% SDS). That is, the energy content of the nucleic acid duplex is decreased. The reference oligonucleotide is 5'-GTCATACTCCTGCTTGCTGATCCACATCTG-3' [SEQ ID NO:9] as the immobilized oligonucleotide and 5'-
5 TGTGGATCAGCAAGCAGGAGTATG-3' [SEQ ID NO:10] as the solution nucleotide which is typically labeled at the 5'-end with a fluorochrome such as Texas Red. The oligonucleotide duplex (24 nucleotides in length) has a helical to coil transition (HCT) of 25°C or less. The HCT is the difference between the temperatures at which 80% and 20% of the duplex is single stranded. The average minimum slope
10 for a solution to be defined as a hybotrope is the first derivative of the HCT and is equal to 2.4 in units of 1/temperature in degrees C ((80% single strand - 20% single-strand)/25°C).

As used herein, "T_m" is the temperature at which half the molecules of a nucleic acid duplex are single stranded. T_m is measured in solution, while T_d is
15 measured for the duplex affixed to a solid support, both terms indicate the temperature at which half of a duplex are single stranded.

As used herein, "stringency" is the percentage of mismatched base pairs that are tolerated for hybridization under a given condition.

As used herein, "discrimination" is the difference in T_d between a
20 perfectly base-paired duplex and a duplex containing a mismatch.

As used herein, a "discrimination temperature" is a temperature at which a hybridization reaction is performed that allows detectable discrimination between a mismatched duplex and a perfectly matched duplex.

25 2. **Solid Support**

An array 10 of solid-phase sample-retaining assemblies 12 in accordance with an exemplary embodiment of the present invention is shown in the figures for illustrative purposes. As best seen in Figure 1, the array 10 includes a plurality of sample-retaining assemblies 12 attached to a base structure 14. Each sample-retaining
30 assembly 12 includes a support pin 16 securely fixed at one end 18 to the base 14, and a

sample-retaining tip structure 20 is attached to the other end 22 of the support pin 16. Each tip structure 20 in the exemplary embodiment is a Nylon 6/6 solid support structure, and the Nylon 6/6 is coated with a poly(ethyleneimine) (PEI) layer 24 or other selected chemical layer. The PEI layer 24 or other selected chemical layer is adapted to
5 bind to a selected biomolecule to form a solid phase sample that is used in a procedure for synthesizing or detecting one or more nucleic acids.

The array 10 of the illustrated embodiment includes eight substantially parallel rows of twelve sample-retaining assemblies 12 to define an array with ninety-six sample-retaining assemblies equally spaced along the base structure 14. Each
10 sample-retaining assembly 12 has approximately the same length so the tip structures 20 are equally spaced from the base, thereby defining a substantially coplanar array of solid-phase sample-retaining tip structures. The tip structures 20 are spaced apart to mate with a conventional 96-well Cetus plate or microtiter plate that is adapted to receive and retain selected liquid samples of biomolecules or nucleic acids. While the
15 exemplary embodiment has an 8 x 12 array of sample-retaining assemblies 12, alternate embodiments have other configurations, including a 1 x 8 array, a 1 x 12 array, and a 4 x 12 array, as well as larger arrays such as a 16 x 24 array.

In the exemplary embodiment, the ninety-six tip structures 20 are adapted to be dipped into the wells of the Cetus plate with the biomolecules therein
20 such that the biomolecules chemically bind to the PEI layer 24. When the tip structures 20 are removed from the sample, the biomolecules are adhered to the PEI layer, thereby forming the solid-phase sample of the biomolecule. The tip structures 20 with the solid phase sample thereon can then be used in synthesizing or analyzing procedures, such as a solid-phase nucleic acid assay and detection process as described in greater detail
25 below.

In one embodiment, the array 10 is installed in a robotic or automatic actuator so the base 14 is clamped into the actuator and the sample-retaining assemblies 12 project away from the base. The actuator quickly and accurately moves the array 10 during automated testing to selected controlled positions or stations in accordance with
30 a predetermined testing, synthesizing, or analyzing process. Such automated testing

with the array 10 and the ninety-six solid phase samples allows for substantially faster testing, synthesizing, or analyzing procedures.

The array 10 is well suited for such automated processing, in part, because of the support pins 16 of the sample-retaining assemblies 12. As best seen in Figure 2A, each support pin 16 is a spring probe that is typically used for construction and testing of electronic components, but has been adapted for use in the present invention. The spring probe generally includes a housing 28 encasing a biasing member 30. A plunger 32 extends into the housing 28 so a first end 34 of the plunger is within the housing 28 adjacent to the biasing member and a second end 36 is exterior of the housing. The biasing member 30 in the exemplary embodiment is a compression spring that pushes axially against the plunger 32 toward the base 14. The plunger's first end 34 has a shoulder 38 that engages a stop 40 projecting radially inwardly from the housing 28 to limit the maximum extension of the plunger 32 with respect to the housing. The plunger's second end 36 is fixedly attached to the base 14, and the plunger 32 projects substantially perpendicularly away from the base.

In the exemplary embodiment, the housing 28 includes concentric inner and outer tubular barrels 42 and 44, wherein the biasing member 30 and the plunger's first end 34 are contained within the inner barrel. The outer barrel 44 removably receives the inner barrel 42 therein and frictionally engages the inner barrel such that the inner and outer barrels are removably attached to each other. The outer barrel 44 terminates at a distal end portion 46 that is spaced away from the base 14 and that connects to the tip structure 20. Accordingly, the housing's outer barrel 44 and the tip structure 20 are removable as a unit from the inner barrel 42 and plunger 32, which remain fixed to the base 14. Thus, an outer barrel 44 and tip structure 20 can be easily and quickly replaced as a unit without having to replace the entire spring probe. Suitable spring probes are available from Everett Charles (Pomona, California), Interconnect Devices, Inc. (Kansas City, Kansas), Test Connections, Inc. (Upland, California), and other manufacturers. While the exemplary embodiment utilizes spring probes as the support pins 16, other support pins, including biased or unbiased support pins, are used in alternate embodiments of the invention.

As best seen in Figure 2B, an alternate embodiment of the invention includes the spring probe as the support pin 16, but the spring probe is oriented 180° from the embodiment described above and illustrated in Figure 2A. For example, the distal end portion 46 of the outer barrel 44 is fixedly attached to the base 14 and the second end 36 of the plunger 32 is spaced away from the base and connected to the tip structure 20.

The spring probes provide a safety feature that protects the array 10 from being damaged during operation. During a sampling or analyzing process, for example, wherein the array 10 is moved to selected positions and the tip structures 20 are dipped into Cetus plate wells or the like, and if the support pins 16 or tip structures inadvertently impacts a surface or other object, the spring probe will compress axially to absorb the impact and then return to the uncompressed position.

As best seen in Figure 3, the tip structure 20 of the exemplary embodiment has a truncated-conical shape with a plurality of channels or flutes 50 formed therein. The tip structure is connectable to a support pin, or may be unitary with the support pin. The flutes 50 are V-shaped flutes that extend axially between a flat distal face 48 and a flat proximal face 54. The flutes 50 have veins or ridges 52 that converge from the proximal face 54 toward the distal face 48 at a selected angle. The truncated conical shape of the tip structure 20 is selected so it virtually identically matches the lower cross-sectional shape of a Cetus plate well. Accordingly, the tip structure 20 is shaped and sized to fit in a very precise position within the Cetus plate well.

The tip structure 20 includes a pin-receiving aperture 56 with an open proximal end 58 in the proximal face 54 and a closed distal end 60 at a mid-portion between the tip structure's proximal and distal faces 54 and 48, respectively. The pin-receiving aperture 56 is shaped and sized to removably receive the support pin's distal end portion 46. Accordingly, the tip structure 20 is removably connected to the support pin 16. However, the tip structure could alternatively be permanently connected to the pin, and in fact the pin and tip structure could be a single unitary structure.

In the illustrated embodiment, the pin-receiving aperture 56 is coaxially aligned with the tip structure's longitudinal axis. The aperture's proximal portion 59 is generally funnel-shaped such that the aperture's open proximal end 58 has a larger diameter than the closed distal end 60. The funnel-shaped proximal portion 59 is adapted to receive the support pin's distal end portion 46 therein. In the event the support pin is slightly misaligned relative to the aperture 56 during an installation procedure, the funnel-shaped proximal portion 59 will receive and direct the support pin 16 into a position such that the spring probe is coaxially aligned with the tip structure 20.

As best seen in Figure 4, the aperture 56 in the exemplary embodiment is defined by an axial interior wall 61 of the tip structure 20 and has a substantially circular cross-sectional shape. The spring probe's distal end portion 46, however, has a substantially square cross-sectional shape with four corners 63. The spring probe's distal end portion 46 is sized such that the corners 63 frictionally engage the tip structure's interior wall 61 so as to frictionally retain the tip structure 20 on the support pin 16.

In an alternate embodiment of the invention, the end portion has a polygonal-shaped cross-sectional area with a plurality of corners that engage the tip structure's interior wall 61. As an example, an octagonal-shaped cross-sectional area having the eight corners that frictionally engage the interior wall 61. In another alternate embodiment, the support pin's distal end portion has a circular cross-sectional shape that substantially corresponds to the circular cross-sectional area of the pin-receiving aperture 56 such that the tip structure 20 is press-fit onto the spring probe's distal end portion 46 and is frictionally retained thereon. In another embodiment, the tip structure 20 is adhered to the distal end portion 46 with a conventional adhesive such that the tip structure is permanently affixed to the support pin 16.

As best seen in Figure 4, the flutes 50 and ridges 52 define the truncated conical-shaped tip structure 20 with a generally star-shaped cross-sectional area. As a result, the tip structure 20 has an enlarged exterior surface 62 so a greater amount of biomolecules can attach to the PEI layer 24 during formation of the solid-phase sample.

In the exemplary embodiment, the flutes 50, ridges, distal face 48 and proximal face 54 of the tip structure 20 define a high-surface area, Nylon 6/6 solid support that is covalently bonded to the PEI layer 24. In alternate embodiments, the tip structure 20 is made of a solid substrate, such as glass or silicon and the PEI layer 24 is covalently bound to the solid substrate using sililating chemistry, as discussed in greater detail below.

In an alternate embodiment, the exterior surface 62 of the tip structure 20 along the flutes 50 and ridges 52 is dimpled so as to provide a further increased surface area along which the PEI layer 24 will bind. In one embodiment, the dimples are generally microscopic, and in an alternate embodiment, the dimples are macroscopic. Accordingly, the dimpled tip structure 20 provides a larger reaction surface for greater efficiency in the synthesizing or analyzing procedures.

During selected synthesizing or analyzing procedures, the tip structure 20 is thermocycled, wherein the tip structure 20 is cycled between high and low temperatures. The ridges 52 of the tip structure 20 form a plurality of heat exchange fins 64 that allow for faster temperature change of the tip structure during the thermocycling. As a result, the thermocycling can be done faster and more efficiently.

As best seen in Figure 5, the array 10 is adapted to be combined and used with a Cetus or microtiter plate 70 having a plurality of wells 72 therein. As discussed above, the shape of a portion of the well 72 substantially matches the truncated conical shape of the tip structure 20. Accordingly, the ridges 52 substantially engage sidewalls 74 of the well 72 and the tip structure's flat distal face 48 is positioned against the bottom 76 of the well. In the preferred embodiment, the microtiter plate 70 has an array of wells formed by eight substantially parallel rows of twelve wells 72 to form the ninety-six well configuration that mates with the tip structures of the array 10. In other embodiments, the microtiter plates 70 have arrays of 1 x 8 wells, 1 x 12 wells, and 4 x 12 wells, as well as larger arrays such as a 16 x 24 well format.

During use of the array 10, the array can be automatically or manually moved from a raised position, shown in solid lines in Figure 5 with the tip structures 20 being out of the wells 72, to a lowered position, shown in phantom lines with the tip

structures being positioned within the wells 72. The wells 72, in one example, contain a liquid sample with the selected biomolecules therein. When the array 10 is in the lowered position and the tip structures 20 are in the liquid sample, the chemical reaction occurs between the PEI layer 24 and the biomolecule, so as to form the selected solid-phase sample of the biomolecule. In the exemplary embodiment, the well 72 has a depth that is approximately 33% larger than that of the tip structure 20, so when the tip structure is dunked into the well, the liquid sample flows over the entire tip structure to bind as much of the biomolecule as possible.

As best seen in Figure 6, the array 10 of sample-retaining assemblies 12 is also usable by positioning the tip structures 20 within the wells 72 and separating the tip structures from the support pins 16, as shown in solid lines, so the tip structures remain in the wells. The base 14 and support pins 16 are then moved as a unit away from the microtiter plate 70. As a result, the microtiter plate 70 with the ninety-six tip structures 20 retained or stored within the wells 72 can be moved as a unit and, as an example, placed in cold storage or other suitable storage locations until the solid-phase samples are needed for a selected synthesizing or analyzing procedure.

In the exemplary embodiment, the wells 72 retain the tip structures 20 in a very precise location relative to the microtiter plate 70 so the tip structures can be easily and substantially simultaneously installed onto the support pins 16. As an example, the microtiter plate 70 is held in a known and fixed location, and the base 14 and support pins 16 are moved as a unit, either automatically or manually to a selected position above the wells 72 such that the support pins substantially coaxially align with the pin-receiving aperture 56 in the tip structures. The base 14 and support pins 16 are then moved toward the microtiter plate 70 such that the support pins 16 are pressed into the apertures in the tip structures, thereby releasably connecting the tip structures to the support pins. The base 14, support pins 16, and tip structures 20 are then moved as a unit away from the microtiter plate 70, thereby removing the tip structures 20 from the wells 72. The sample-retaining tip assemblies 12 with solid phase samples thereon can be moved to a predetermined location and subjected to selected solid-phase procedures for analyzing or synthesizing a nucleic acid.

The solid supports of the present invention can be used in parallel and are preferentially configured in a 96-well or 384-well format. The solid supports can be attached to pegs, stems, or rods in a 96-well or 384-well configuration, the solid supports either being detachable or alternatively integral to the particular configuration.

5 The particular configuration of the sold supports is not of critical importance to the functioning of the assay, but rather, affects the ease of adapting the assays to automated systems.

3. Methods for Binding Nucleic Acid Molecules to a Solid Support

10 The tips described herein are useful in a variety of methods requiring attachment of a nucleic acid molecule, peptide, polypeptide, or protein to a solid support. Examples of solid-phase assays and detection methods that can be performed with such tips are described below.

Standard methods can be used to attach a nucleic acid molecule to the
15 tips. For example, nucleic acid molecules, modified at their 5'-ends with an aldehyde or carboxylic acid, can be attached to a solid support having hydrazide residues (*see*, for example, Kremsky et al., *Nucleic Acids Res.* 15:2891, 1987). Alternatively, 5'-aminohexyl phosphoramidate derivatives of oligonucleotides can be coupled with a solid support bearing carboxyl groups in a carbodiimide-mediated coupling reaction
20 (*see*, for example, Ghosh et al., *Nucleic Acids Res.* 15:5353, 1987).

The solid supports are preferentially coated with an amine-polymer such as polyethylene(imine), acrylamide, amine-dendrimers, *etc.* The amines on the polymers are used to covalently immobilize nucleic acids. Preferably, nucleic acids are bound to the solid supports described herein using poly(ethyleneimine) (PEI) coatings.
25 The chemistry used to adhere a layer of PEI to the substrate depends, in substantial part, upon the chemical identity of the substrate. The prior art provides numerous examples of suitable chemistries that may adhere PEI to a solid support. For example, when the substrate is nylon-6/6, the PEI coating may be applied by the methods disclosed in Van Ness, et al. *Nucleic Acids Res.* 19:3345, 1991, and International
30 Publication No. WO 94/00600. Suitable methods of applying a layer of PEI to solid

supports of glass or silicon are described, for example, by Wasserman, *Biotechnology and Bioengineering XXII:271*, 1980, and by D'Souza, *Biotechnology Letters 8:643*, 1986.

Preferably, the PEI coating is covalently attached to the solid substrate.

5 When the solid substrate is glass or silicon, the PEI coating may be covalently bound to the substrate using silylating chemistry. For example, PEI having reactive siloxy endgroups is commercially available from Gelest, Inc. (Tullytown, PA). Such reactive PEI may be contacted with a glass or silicon tip, and after gentle agitation, the PEI will adhere to the substrate. Alternatively, a bi-functional silylating reagent may be
10 employed. According to this process, the glass or silicon substrate is treated with the bi-functional silylating reagent to provide the substrate with a reactive surface. PEI is then contacted with the reactive surface, and covalently binds to the surface through the bi-functional reagent.

PEI coatings are preferably used to immobilize nucleic acids to the
15 nylon tips, described herein. One suitable method of coating nylon-6/6 with PEI has been described by Van Ness et al., *Nucleic Acids Res. 19:3345*, 1991. Briefly, the nylon substrate is ethylated using triethyloxonium tetrafluoroborate to form amine-reactive imidate esters on the nylon surface. The activated nylon is then reacted with PEI to form a polymer coating that provides an extended amine surface. Following
20 activation of 5'-aminohexyl-tailed oligonucleotides with 2,4,6-trichloro-1,3,5-triazine (cyanuric chloride), the modified oligonucleotides are covalently attached to the nylon surface via the triazine moiety.

Accordingly, preferred nucleic acid polymers are "amine-modified" in that they have been modified to contain a primary amine at the 5'-end of the nucleic
25 acid polymer, preferably with one or more methylene groups disposed between the primary amine and the nucleic acid portion of the nucleic acid polymer. Six is a preferred number of methylene groups.

Nucleic acid molecules can be modified by addition of amine moieties using standard techniques. Products of a polymerase chain reaction, for example, can
30 be arrayed using 5'-hexylamine-modified primers. Nucleic acid duplexes can be

arrayed after the introduction of amines by nick translation using amine allyl-dUTP (Sigma, St. Louis, MO). Amines can also be introduced into nucleic acids by polymerases such as terminal transferase with amino allyl-dUTP or by ligation of short amine-containing nucleic acid polymers onto nucleic acids by ligases.

5 Preferably, the nucleic acid polymer is activated prior to be contacted with the PEI coating. This can be conveniently accomplished by combining amine-functionalized nucleic acid polymer with a multi-functional amine-reactive chemical such as cyanuric chloride. For example, an excess of cyanuric chloride can be added to a solution containing the nucleic acid polymer solution. Preferably, the solution would
10 contain a 10- to 1000-fold molar excess of cyanuric chloride over the number of amines in the nucleic acid polymer in the arraying solution. In this way, the majority of amine-terminated nucleic acid polymers have reacted with one molecule of cyanuric chloride, so that the nucleic acid polymer becomes terminated with dichlorotriazine.

 An advantageous feature of the present invention is that the
15 biomolecule-containing arraying solutions may be deposited onto a PEI coating even though that arraying solution contains a significant amount of the multi-functional amine-reactive chemical. This provides a significant advantage over methods wherein coupling agent needs to be removed from an arraying solution prior to an arraying process.

20 When the nucleic acid polymer is double-stranded, both strands or one of the strands contains a terminal amino group. The double-stranded nucleic acid polymer may be bonded through one terminal amino group to the PEI coating to immobilize the double-stranded polymer. Since only one of the two strands is covalently bonded to the PEI coating, the other strand may be removed under
25 denaturing and washing conditions. This approach provides one convenient method according to the present invention of achieving an array of single-stranded nucleic acid polymers. The double-stranded nucleic acid polymer may be obtained, for example, as a reaction product from PCR.

 Preferably, the arraying solution is buffered using a common buffer such
30 as sodium phosphate, sodium borate, sodium carbonate, or Tris-HCl. A preferred pH

range for the arraying solution is 7 to 9, with a preferred buffer being freshly prepared sodium borate at pH 8.3 to pH 8.5.

Various methods described below require the use of oligonucleotides bound to the solid supports of the present invention. Preferably, oligonucleotides are synthesized with a 5'-amine (generally a hexylamine which is a six carbon spacer-arm and a distal amine). Typically, oligonucleotides are 15 to 50 nucleotides in length, and are activated with homo-bifunctional or hetero-bifunctional cross-linking reagents such as cyanuric chloride. The activated oligonucleotides can be optionally purified from excess cross-linking reagent (*e.g.*, cyanuric chloride) by exclusion chromatography. The activated oligonucleotides are then mixed with the solid supports to effect covalent attachment. After covalent attachment of the oligonucleotides, the unreacted amines of the solid support are capped (*e.g.*, with succinic anhydride) to eliminate the positive charge of the solid support.

Certain methods require the use of biotinylated oligonucleotides that bind to streptavidin, which in turn, is bound to a solid support. Methods for producing biotinylated nucleic acid molecules and support-bound streptavidin are well known to those of skill in the art. For example, Van Ness et al., *Nucleic Acids Res.* 19:3345 (1991), describe a method for biotinylation of oligonucleotides, in which oligonucleotides are treated with activated biotin. Alternatively, biotinylated oligonucleotides can be prepared by synthesizing oligonucleotides with biotin-labeled dNTPs (*see*, for example, Ausubel et al. (eds.), *Short Protocols in Molecular Biology, 3rd Edition*, pages 12-23 to 12-25 (John Wiley & Sons, Inc. 1995)). Methods for biotinylating nucleic acids are well known in the art and are described, for example, in *Avidin-Biotin Chemistry: A Handbook* (Pierce Chemical Company 1992). Standard methods that can be used to bind streptavidin to the tips of the present invention are provided, for example, by Das and Fox, *Ann. Rev. Biophys. Bioeng.* 8:165, 1979, and by Wilchek and Bayer, *Anal. Biochem.* 171:1, 1983.

The tips described herein can also be used to assay peptides. General guidelines for the conjugation of peptides, polypeptides, and proteins to solid supports are provided, for example, by Wong, *Chemistry of Protein Conjugation and Cross-*

linking (CRC Press, Inc. 1991), and by Partis et al., *J. Protein Chemistry* 2:263 (1983). The use of peptides and antibodies in solid phase procedures is known from, for example, Vaughn et al. *Nature Biotechnology* 14:309, 1996 and Huse et al. *Science* 246:1275, 1989.

5

4. Use of Solid Supports in cDNA Synthesis

As discussed above, there is an increasing need to synthesize cDNA on solid supports. These cDNA molecules can be used to create cDNA libraries and as probes for gene expression analyses and diagnostic assays. The design of the disclosed
10 solid support addresses the following problems in current cDNA-dependent technologies: high input of RNA required, low number of sample throughput, many user manipulations, organic extractions and precipitations, vector bias for insert size and poor adaptability. One advantage of the solid-phase approach is that cDNA synthesis in solution requires a large number of steps with intermediate precipitation
15 steps.

There are various approaches for producing a cDNA molecule on a specialized solid support as described in this disclosure. The following general scheme provides one illustration. First, RNA is prepared using standard techniques. In the studies described in Example 1, total RNA was prepared by acid-guanidinium-phenol
20 extraction, using well known methods (*see*, for example, Ausubel et al. (eds.), *Short Protocols in Molecular Biology*, 3rd Edition, pages 4-4 to 4-6 (John Wiley & Sons, Inc. 1995); Wu et al., *Methods in Gene Biotechnology*, pages 33-34, (CRC Press 1997)). Messenger RNA is then captured on a solid support, for example, that contains oligonucleotides having oligo(dT) tails.

25 Alternatively, it is possible to use a simultaneous lysis-mRNA capture protocol using a chaotrope, such as guanidinium thiocyanate or guanidine hydrochloride, for both cell lysis and hybridization. This approach permits the lysis of a small number of cells. According to this method, DNA is removed by passing the lysate through a glass fiber filter, mRNA is captured on the solid support, and unbound
30 contaminants and material are washed away. This avoids losses associated with organic

phase extractions and serial ethanol precipitations inherent in standard RNA preparation procedures.

Support-bound RNA is used as a template to produce the first strand of cDNA, using standard methods. Then, the second strand of cDNA is synthesized or an
5 adapter is placed at the distal end of the first strand cDNA. As an illustration, it is possible to place three dNGs at the 3' end of the first strand using, for example, terminal transferase. Alternatively, an adaptor can be ligated onto the 3' end of the cDNA molecule. A complementary primer is then hybridized to the adaptor. The second strand cDNA strand is then synthesized using the first strand of cDNA as a
10 template.

Alternatively, either random or specific sequences of bound RNA can be amplified using a polymerase chain reaction (PCR). In brief, PCR is a process based on a specialized polymerase, which can synthesize a complementary strand to a given DNA strand in a mixture containing deoxyribonucleotides and two DNA primers, each
15 about 20 bases long, which flank the target sequence. The mixture is heated to separate the strands of double- stranded DNA containing the target sequence and then cooled to allow the primers to bind to their complementary sequences on the separated strands. The polymerase then extends the primers into new complementary strands. Repeated heating and cooling cycles multiply the target DNA exponentially, since each new
20 double strand separates to become two templates for further synthesis. In about one hour, 20 PCR cycles can amplify the target by a million-fold. Standard methods for performing PCR are well-known to those of skill in the art (*see*, for example, Delidow et al., "Polymerase Chain Reaction: Basic Protocols," in *PCR Protocols: Current Methods and Applications*, White (ed.), pages 1-29 (Humana Press, Inc. 1993);
25 Ausubel et al. (eds.), *Short Protocols in Molecular Biology*, 3rd Edition, pages 15-1 to 15-40 (John Wiley & Sons, Inc. 1995)).

Accordingly, one can add a primer that is complementary to known part of bound mRNA. It is then possible to amplify using a specific primer and a primer complementary to adaptor. Following amplification, typically 5-15 rounds of
30 thermocycling, the resulting DNA fragments can then be cloned and the 5' end of the

sequence can be determined. It is then possible to synthesize a new hybrid primer that contains sequences that are complementary to the adaptor and to 5' end of gene. The full length cDNA is then amplified from the solid support.

A modification of PCR, called "anchor PCR," allows amplification of
5 full-length mRNA even though only a small amount of sequence information is available (Ausubel et al. (eds.), *Short Protocols in Molecular Biology*, 3rd Edition, pages 15-27 to 15-32 (John Wiley & Sons, Inc. 1995)). This procedure requires an oligo(dT) primer that is either complementary to the poly(A) tail of mature mRNA, when amplifying downstream to the known sequence, or complementary to a
10 synthesized homopolymer tail added to the cDNA following first-strand synthesis, when amplifying upstream to the known sequence.

There are at least two branching points in these general cDNA synthesis methods which provide starting junctures for additional techniques that take advantage of solid support methodology. One branch point follows first strand cDNA synthesis.
15 At this point, the remaining RNA template can be digested with RNaseH, hydrolyzed in sodium hydroxide or removed by heat denaturation, leaving a single-stranded DNA template which can be used for oligonucleotide-directed second strand synthesis, PCR, random-primed probe production, or gene-expression studies using labeled oligonucleotides. The bound cDNA can also be used for preparing a subtracted library
20 or differential probes for various applications.

Second strand cDNA synthesis represents a second branch-point in the solid support cDNA technology. Here, the choice can be made to ligate adapters to the cDNA that can support processes such as full-length single-stranded cDNA probes, library production, *in vitro* transcription, and 5' RACE.

25 An important advantage to solid support cDNA synthesis is the ability to automate the process. For high through-put cDNA library production or gene expression studies, it is useful to adapt the solid support described herein to a 96-well format. A robotic arm can be used to deliver 96 supports onto 96 gold-plated pins and direct cDNA synthesis in a standard 96-well Cetus plate.

5. Analysis of Gene Expression

The solid supports described herein can be used in high through-put methods for examining the expression of numerous genes (1-2000) in a single measurement. Such methods can be performed in parallel with greater than one hundred samples per process. The method is applicable to drug screening, developmental biology, molecular medicine studies and the like. Thus, within one aspect of the invention methods are provided for analyzing the pattern of gene expression from a selected biological sample, comprising the steps of (a) exposing nucleic acids from a biological sample, (b) combining the exposed nucleic acids with one or more selected detectably-labeled nucleic acid probes, under conditions and for a time sufficient for the probes to hybridize to the nucleic acids, wherein the detectable label is correlative with a particular nucleic acid probe and detectable by spectrometry, or potentiometry, (c) separating hybridized probes from unhybridized probes, (d) detecting the label by spectrometry or potentiometry, and (e) determining therefrom the pattern of gene expression of the biological sample.

Within a particularly preferred embodiment of the invention, assays or methods are provided which are performed as follows. RNA from a target source is bound to a solid support through a specific hybridization step (*e.g.*, capture of poly(A) mRNA by a tethered oligo(dT) capture probe). The solid support is then washed and cDNA is synthesized on the solid support using standard methods (*i.e.*, reverse transcriptase). The RNA strand is then removed via hydrolysis. The result is the generation of a DNA population, covalently immobilized to the solid support, which reflects the diversity, abundance, and complexity of the RNA from which the cDNA was synthesized. The solid support is then hybridized with one to several thousand probes which are complementary to a gene sequence of interest. Each probe type is labeled with a tag detectable by spectrometric method, such as mass spectrometry. After the interrogation step, excess or unhybridized probe is washed away, the solid support is placed, for example, in the well of a microtiter plate and the detectable tag is cleaved from the solid support. The solid support is then removed from the well of sample container, and the contents of the well are measured with a spectrometer. The

appearance of specific tags indicate the presence of RNA in the sample and evidence that a specific gene is expressed in a given biological sample. The method can also be quantifiable.

The compositions and methods for the rapid measurement of gene
5 expression using cleavable tags can be described in detail as follows. Briefly, tissue, primary or transformed cell lines, isolated or purified cell types or any other source of biological material in which determining genetic expression is useful can be used as a source of RNA. In the preferred method, the biological source material is lysed in the presence of a chaotrope to suppress nucleases and proteases, and to support stringent
10 hybridization of target nucleic acid to the solid support. Tissues, cells and biological sources can be effectively lysed in one to six molar chaotropic salts (guanidine hydrochloride, guanidine thiocyanate, sodium perchlorate, *etc.*).

After the source biological sample is lysed, the solution is mixed for 15 minutes to several hours with the solid support to effect immobilization of the target
15 nucleic acid. In general, the capture of the target nucleic acid is achieved through complementary base pairing of target RNA and the capture probe immobilized on the solid support. One permutation utilizes the 3' poly(A) stretch found on most eukaryotic messenger RNAs to hybridize to a tethered oligo(dT) on the solid support. Another permutation is to utilize a specific oligonucleotide or long probes (greater than 50
20 bases) to capture an RNA containing a defined sequence.

Another possibility is to employ degenerate primers (oligonucleotides) that would effect the capture of numerous related sequences in the target RNA population. For example, RNA samples can be reversed-transcribed with each of four sets of degenerate anchored oligo(dT) primers, having the formula 5'-T₁₂MN-3', where
25 M can be G, A or C, and N is G, A, T, and C (Ausubel et al. (eds.), *Short Protocols in Molecular Biology, 3rd Edition*, pages 15-35 to 15-40 (John Wiley & Sons, Inc. 1995)). Each primer set is dictated by the 3'-base, with degeneracy in the M position.

Hybridization times are guided by the sequence complexity of the RNA population and the type of capture probe employed. Hybridization temperatures are
30 dictated by the type of chaotrope employed and the final concentration of chaotrope.

General guidelines are provided, for example, by Van Ness and Chen, *Nucleic Acids Res.* 19:5143, 1991. The lysate is preferentially agitated with the solid support continually to effect diffusion of the target RNA. After capturing the target nucleic acid, the lysate is washed from the solid support and all chaotrope or hybridization
5 solution is removed. The solid support is preferentially washed with solutions containing ionic or non-ionic detergents, buffers and salts.

The next step is the synthesis of DNA complementary to the captured RNA, in which the tethered capture oligonucleotide serves as the extension primer for reverse transcriptase. The reaction is generally performed at 25 to 37°C, and preferably
10 agitated during the polymerization reaction. After the cDNA is synthesized, it becomes covalently attached to the solid support since the capture oligonucleotide serves as the extension primer. The RNA is then hydrolyzed from the cDNA/RNA duplex. The step can be effected by the use of heat which denatures the duplex or the use of base (*i.e.*, 0.1 N NaOH) to chemically hydrolyze the RNA. The objective of this step is to make
15 the cDNA available for subsequent hybridization with defined probes. The solid support or set of solid supports are then further washed to remove RNA or RNA fragments. At this point, the solid support contains an approximate representative population of cDNA molecules that represents the RNA population in terms of sequence abundance, complexity, and diversity.

20 The next step is to hybridize selected probes to the solid support to identify the presence or absence and the relative abundance specific cDNA sequences. Probes are preferentially oligonucleotides in length of 15 to 50 nucleotides. The sequence of the probes is dictated by the end-user of the assay. For example, if the end-user intends to study gene expression in an inflammatory response in a tissue,
25 probes would be selected to be complementary to numerous cytokine mRNAs, RNAs that encode enzymes that modulate lipids, RNAs that encode factors that regulate cells involved in an inflammatory response, etc. Once a set of desired sequences is defined for study, each sequence is used to design an oligonucleotide probe, and each probe is assigned a specific cleavable tag. The tag(s) is then attached to the respective
30 oligonucleotide(s). The oligonucleotides are then hybridized to the cDNA on the solid

support under appropriate hybridization conditions. After completion of the hybridization step, the solid support is washed to remove any unhybridized probe. The solid support or array of supports are then placed in solutions which effect the cleavage of the detectable tags. The presence (and abundance) of an expressed mRNA is
5 determined by measuring the amount of detectable tags. For example, mass spectrometer tags are examined using a mass spectrometer.

There are numerous variations of the above-described method for analyzing differential expression. For example, differential expression can be examined using a subtracted library. Subtraction of redundant messages to reveal
10 patterns of gene expression representative of particular states of activation or development is a desirable capability of any gene discovery program. Many protocols exist for production of subtracted cDNA libraries, but most require either large amounts of RNA or pre-existing cDNA libraries. The use of a solid support to capture mRNA, allows the message source representing the background to be subtracted. Desired
15 mRNA species are reverse transcribed and RNA templates are destroyed with alkali. The resulting "subtraction template" can be re-used indefinitely.

To make a subtracted library, RNA from the source under investigation is heat-denatured then hybridized to the first strand of cDNA on the subtraction template. Unbound RNA is then washed away and either captured directly or
20 hybridized a second time after all the bound, subtracted RNA has been eluted from the subtraction template. After capture, cDNA synthesis continues as described previously.

In a related approach, subtractive cDNA probes are prepared by hybridizing single-stranded cDNA from one cell type with immobilized mRNA from a closely-related cell type, and isolating the small fraction of unhybridized cDNA. As a
25 result of this enrichment, DNA fragments of subtractive cDNA can be used to identify cDNA clones containing differentially expressed sequences. Subtractive cDNA can also be used to prepare subtractive cDNA libraries. PCR can be used to amplify subtractive cDNA for use as probes or for cloning (*see*, for example, Kuel and Battey, "Generation of a Polymerase Chain Reaction Renewable Source of Subtractive cDNA,"
30 in *PCR Protocols: Current Methods and Applications*, White (ed.), pages 287-304

(Humana Press, Inc. 1993); Wu et al., *Methods in Gene Biotechnology*, pages 29-65, (CRC Press 1997)).

In yet another variation, a biotinylated oligo(dT)MN molecule, the degenerate primer described above, is used to bind mRNA to a solid support, and to
5 prime first strand synthesis (*see*, for example, Røsok et al., *BioTechniques* 21:114, 1996). After reverse transcription, the solid-phase cDNA is used as a template in a polymerase chain reaction, with the biotinylated oligo(dT)MN and an arbitrary decamer as primers. PCR products obtained from two cell populations are then compared following fractionation by polyacrylamide gel electrophoresis, PCR bands of interest
10 are eluted from the gel, and purified PCR products are used as templates for an additional polymerase chain reaction, which amplifies the selected bands. The products of the second polymerase chain reaction can be used as probes, or can be further examined by sequence analysis.

15 6. **Solid-Phase Diagnostic Assays**

(A) Detection of Polymorphisms

Restriction endonucleases recognize short DNA sequences and cleave DNA molecules at those specific sites. Certain restriction enzymes cleave DNA very infrequently, generating a small number of very large fragments (several thousand to a
20 million base pairs). Most restriction enzymes cleave DNA more frequently, thus generating a large number of small fragments (less than a hundred to more than a thousand base pairs). On average, restriction enzymes with four-base recognition sites will yield pieces 256 bases long, six-base recognition sites will yield pieces 4000 bases long, and eight-base recognition sites will yield pieces 64,000 bases long. Since
25 hundreds of different restriction enzymes have been characterized, DNA can be cleaved into many different small fragments.

Although a few known human DNA polymorphisms are based upon insertions, deletions or other rearrangements of non-repeated sequences, the vast majority are based either upon single base substitutions or upon variations in the
30 number of tandem repeats. Base substitutions are very abundant in the human genome,

occurring on average once every 200-500 base pairs. Length variations in blocks of tandem repeats are also common in the genome, with at least tens of thousands of interspersed polymorphic sites, or "loci." Repeat lengths for tandem repeat polymorphisms range from one base pair in $(dA)_n(dT)_n$ sequences to at least 170 base pairs in α -satellite DNA. Tandem repeat polymorphisms can be divided into two major groups which consist of minisatellites/variable number of tandem repeats (VNTRs), with typical repeat lengths of tens of base pairs and with tens to thousands of total repeat units, and microsatellites, with repeat lengths of up to six base pairs and with maximum total lengths of about 70 base pairs. Most of the microsatellite polymorphisms identified to date have been based on $(dC-dA)_n$ or $(dG-dT)_n$ dinucleotide repeat sequences. Analysis of microsatellite polymorphisms involves amplification by the polymerase chain reaction of a small fragment of DNA containing a block of repeats followed by electrophoresis of the amplified DNA on denaturing polyacrylamide gel. The PCR primers are complementary to unique sequences that flank the blocks of repeats. Polyacrylamide gels, rather than agarose gels, are traditionally used for microsatellites because the alleles often only differ in size by a single repeat.

A wide variety of techniques have been developed for the analysis of DNA polymorphisms. The most widely used method, the restriction fragment length polymorphism (RFLP) approach, combines restriction enzyme digestion, gel electrophoresis, blotting to a membrane and hybridization to a cloned DNA probe. Polymorphisms are detected as variations in the lengths of the labeled fragments on the blots. The RFLP approach can be used to analyze base substitutions when the sequence change falls within a restriction enzyme site, or to analyze minisatellites/VNTRs by choosing restriction enzymes that cut outside the repeat units. The agarose gels do not usually afford the resolution necessary to distinguish minisatellite/VNTR alleles differing by a single repeat unit, but many of the minisatellites/VNTRs are so variable that highly informative markers can still be obtained. (Vos et al., *Nuc. Acids Res.* 23:4407, 1995).

Solid-phase techniques have enhanced the ability to detect polymorphisms. For example, a biotinylated primer is used with allele-specific PCR primers to amplify one form of an allele. After amplification, the PCR products can be detected by solution hybridization to a fluorophore-labeled probe, and hybrids are captured on a solid-phase support bearing streptavidin (*see*, for example, Syvänen and Landegren, *Human Mutation* 3:172, 1994).

In another approach, termed “solid-phase minisequencing,” a biotinylated amplification product is immobilized by a streptavidin-coated support. The amplification product is then used as a template in a sequence-specific extension reaction in the presence of a single nucleoside triphosphate complementary to one of the sequence variants to be distinguished (*see*, for example, Syvänen and Landegren, *Human Mutation* 3:172, 1994; Syvänen, *Clin. Chem. Acta* 226:225, 1994; Järvelä et al., *J. Med. Genet.* 33:1041, 1996).

In the “oligonucleotide-ligation assay,” two differentially-labeled allele-specific oligonucleotides are compared for their ability to ligate to a biotinylated downstream oligonucleotide (*see*, for example, Nickerson et al., *Proc. Natl. Acad. Sci. USA* 87:8923, 1990; Nickerson et al., *Genomics* 12:377,1992). The unlabeled oligonucleotide is immobilized on an avidin-coated solid support that projects into a test well. The presence of the target sequence is determined by measuring the particular signal generated by the bound labeled oligonucleotide. For example, the allele-specific oligonucleotides can be labeled with different fluorophores, and the presence of the target is determined by measuring fluorescence.

Nepom et al., *J. Rheumatol.*23:5 (1996), describe a method for genotyping analysis in which a selected sequence is amplified using PCR with a biological sample of nucleic acid and a biotinylated primer. A small amount of amplified product is transferred to an automated processor instrument that performs allele-specific hybridization and detection.

DNA fingerprinting represents another aspect of polymorphism detection. A variety of DNA fingerprinting techniques are presently available, most of which use PCR to generate fragments (*see*, for example, Jeffries et al., *Nature* 314:67,

1985; Welsh and McClelland, *Nucleic Acids Res.* 19:861, 1991). The choice of which fingerprinting technique to use is dependent on the application (*e.g.*, DNA typing, DNA marker mapping) and the organisms under investigation, (*e.g.*, prokaryotes, plants, animals, humans).

5 In general, DNA fingerprinting can be performed by synthesizing full-length cDNA on a tip of the present invention. The cDNA is then digested with restriction endonucleases, and the unbound material is rinsed from the tip. Adapters are then ligated onto the bound cDNA, and the product can be amplified and analyzed.

 A number of fingerprinting methods have been developed over the past
10 few years, including random amplified polymorphic DNA (RAPD), DNA amplification fingerprinting (DAF), and arbitrarily primed PCR (AP-PCR). These methods are all based on the amplification of random genomic DNA fragments by arbitrarily selected PCR primers. DNA fragment patterns may be generated of any DNA without prior sequence knowledge. The patterns generated depend on the
15 sequence of the PCR primers and the nature of the template DNA. PCR is performed at low annealing temperatures to allow the primers to anneal to multiple loci on the DNA. DNA fragments are generated when primer binding sites are within a distance that allows amplification. In principle, a single primer is sufficient for generating band patterns.

20 A more recent technique for DNA fingerprinting and for detection of polymorphism is the amplified fragment length polymorphism (AFLP) technique (*see*, for example, Vos et al., *Nucleic Acids Res.* 23:4407, 1995; Schreiner et al., *J. Immunol. Methods* 196:93, 1996). Briefly, genomic DNA is digested with restriction endonuclease and ligated with oligonucleotide adapters, PCR provides selected
25 amplification of sets of restriction fragments, and the amplified fragments are analyzed following fractionation by polyacrylamide gel electrophoresis.

 This method is readily adapted to a solid phase using the tips of the present invention. Here, full-length genomic DNA is covalently immobilized on a tip. Bound genomic DNA is then digested with restriction endonucleases, and the unbound

material is washed from the tip. Adapters are then ligated to bound genomic DNA fragments, and the bound DNA molecules are amplified and analyzed.

The AFLP technique has also been applied to mRNA fingerprinting (Habu et al., *Biochem. Biophys. Res. Commun.* 234:516, 1997). In this approach, double-stranded cDNA is synthesized with anchored oligo(dT) primers, and digested with *TaqI*, which recognizes a four-base sequence. A *TaqI* adapter is then ligated to the ends of the cDNA fragments, and PCR amplification is performed with selected primers, following the general methods of AFLP-based genomic fingerprinting. Advantageously, mRNA fingerprinting by the AFLP technique is performed with the solid supports described herein to anchor the oligo(dT) primers.

Mutations can also be identified via their destabilizing effects on the hybridization of short oligonucleotide probes to a target sequence (*see*, for example, Wetmur, *Crit. Rev. Biochem. Mol. Biol.* 26:227, 1991). Generally, this technique of allele-specific oligonucleotide hybridization, involves amplification of target sequences and subsequent hybridization with short oligonucleotide probes. An amplified product can be scanned for many possible sequence variants by determining its hybridization pattern to an array of immobilized oligonucleotide probes. Illustrations of this approach are provided by Examples 6 and 7.

(B) General Diagnostic Methods

DNA probes can be used to detect the presence of infectious agents or diseased cells, such as tumor cells expressing tumor-associated antigens. Typically, a test biological sample is subjected to a lysis step using ionic detergents or chaotropes to release nucleic acid targets. Typical nucleic acid targets include mRNA, genomic DNA, plasmid DNA or RNA, and rRNA viral DNA or RNA. To effect detection of the target nucleic acid, the target requires some type of immobilization. For example, nucleic acids are immobilized on a solid support or substrate which possesses some affinity for nucleic acid. The solid supports are then probed with tagged oligonucleotides of pre-determined sequence to identify the target nucleic acid of interest. Unhybridized probe is removed in a washing step, the tags are cleaved from

their respective probes, and then measured (for a review, *see* Reischl and Kochanowski, *Molec. Biotech.* 3:55, 1995).

In one general type of assay method, oligonucleotides representing a characteristic part of an amplified sequence are attached to a solid support. The attachment may be covalent or via a biotin:streptavidin, or similar, type of linkage. Target nucleic acid is used as a template to produce detectably labeled PCR products. These PCR products are hybridized with the capture oligonucleotides, and the presence of the PCR products is determined by a label-mediated detection reaction.

In a variation of this approach, biotin-labeled PCR products are attached to a streptavidin-coated solid support. Immobilized PCR products are hybridized with a labeled probe complementary to internal sequences of the amplification product.

As a further illustration of a diagnostic method, Wilber, *Immunol. Invest.* 26:9 (1997), describes a solid-phase nucleic acid hybridization assay based on branched DNA signal amplification methods. In this study, HIV RNA was detected in plasma by hybridization of multiple oligonucleotides to the target, 10 of which captured the target onto the surface, and 39 of which mediated hybridization of branched DNA molecules to the pol region of the RNA. Detectably labeled probes bound to each arm of the branched DNA molecules.

Additional detection methods are well-known to those of skill in the art. For example, solid phase detection can be achieved using amplified colorimetric means such as an alkaline phosphatase system, a streptavidin system, or a horseradish peroxidase system. Radiometric detection is another alternative. Suitable radiolabels for radiometric detection include ^3H , ^{125}I , ^{131}I , ^{35}S , ^{14}C , ^{32}P , and the like. Fluorescently-labeled molecules provide yet another means of detection.

The present invention, thus generally described, will be understood more readily by reference to the following examples, which are provided by way of illustration and are not intended to be limiting of the present invention.

EXAMPLES

EXAMPLE 1:

CDNA SYNTHESIS ON THE SOLID SUPPORT

5 (A) RNA Capture

In these studies, total RNA was prepared by acid-guanidinium-phenol extraction, using standard techniques (*see*, for example, Ausubel et al. (eds.), *Short Protocols in Molecular Biology*, 3rd Edition, pages 4-4 to 4-6 (John Wiley & Sons, Inc. 1995)). Polyadenylated mRNA was captured on tips by first heating the mixture of
10 isolated total RNA to 70°C, adding a high salt hybridization solution to the RNA, adding the RNA to the tip solid support having oligo(dT), and then placing the support on a moving platform, such as a rotary mixer. Sufficient mixing was accomplished by a variety of instruments including continual vortexer, orbital shaker, rotary rocker, and a hybridization oven equipped with a rotator.

15 The time required for RNA capture was found to be dependent on the quantity of input RNA. At ambient temperature, 10 µg of total RNA were sufficient to achieve 90% saturation of a tip in approximately two hours. In a typical resting cell, this amount of total RNA corresponds to approximately 100 ng poly(A)+ mRNA bound per tip. Forty micrograms of total RNA from the same source gave the same level of
20 saturation in 30 minutes.

In another series of experiments, a stimulated human T-cell line was used as the RNA source and saturation was reached in one hour under the same capture conditions using a 10 µg RNA input. Several additional RNA sources have been captured including mouse, hamster and human cell lines, and all tend to fall within this
25 range of 90% capture in 1-2 hours per 10 µg total RNA, defining a maximum and minimum incubation time.

(B) First Strand cDNA Synthesis

After capture of poly(A)⁺ mRNA, the tip was washed in hybridization buffer three times to remove unbound RNA. Reverse transcription was performed in a 30 μ l volume containing MMLV-reverse transcriptase (MMLV-RT) and an optimized buffer system for 1-2 hours at 42°C on a hybridization oven rotator rack. As with the capture step, efficient first strand synthesis requires constant mixing of the reagents.

Initial experiments yielded 50-100 ng cDNA per solid support. The products of reverse transcription have been assayed indirectly by autoradiography of labelled double-stranded cDNA cleaved from the tip and sized by agarose gel electrophoresis. In several experiments, the size span of copied mRNA species was comparable to conventional methods and was often longer. The size distribution of the cDNA ranged from 0.5 kilobases - 20 kilobases, with the average being approximately 2.0 kilobases.

(C) Second Strand cDNA Synthesis

After reverse transcription, the tip was washed three times to remove reactants and enzyme. Second strand synthesis was performed in a 40 μ l volume using one unit of RNaseH per 25 units *E. coli* DNA polymerase I. The reaction was incubated at room temperature on a rotary rocker for six hours or overnight.

Unevenly extended ends were "polished" for the subsequent ligation step by removing the second strand reaction and adding T4 DNA polymerase and dNTP's. This incubation proceeded for 30 minutes at 37°C on the rotator in a hybridization oven. Products are visualized directly by running the reaction in the presence of a ³²P-labelled dNTP, and either boiling the second strand products, or by cleavage from the support with the restriction enzyme *AscI*. The radiolabelled products are run on a gel and placed on film for visualization. From a typical input of 10 μ g total RNA, it is possible to recover 50-120 ng double-stranded cDNA, depending on the particular RNA.

The use of a thermostable DNA polymerase after reverse transcription with an enzyme possessing RNaseH activity, such as MMLV-RT is also a possibility.

In this case, the thermostable polymerase digests the RNA template, eliminating the need to remove RNA via a thermal denaturation step.

An experiment comparing RNaseH/DNA pol I versus TthI DNA polymerase in second strand synthesis demonstrated little difference in either the quantity of the *AscI*-cleaved product or the content of that product, which was tested by PCR amplification of selected genes such as GAPDH and IL-2. Using TthI decreases the incubation time from six hours at room temperature to one hour at 70°C. TthI polymerase also shows reverse transcriptase activity in the presence of manganese ions, but incubations need to be kept very short due to the possibility of RNA hydrolysis at high temperature in the presence of divalent cations. Another advantage of performing DNA polymerization at high temperature is that secondary structure is decreased, which aids the synthesis of highly structured messages.

(D) Adapter Ligation-Ligation To Vector

Hemi-phosphorylated adapters were ligated to the double-stranded cDNA in a 30 µl volume with a 5-10:1 molar ratio of adapter:cDNA ends. A preferred ligation buffer contained 10% PEG. The adapter-cDNA mixture was incubated with T4 DNA ligase overnight at room temperature on a rotary rocker. The solid support was then washed three times to remove excess linkers. After ligation, the 5'-hydroxyl group on the adapter was phosphorylated with T4 polynucleotide kinase and ATP for one hour at 37°C on a hybridization oven rotating rack. This reaction was stopped by washing the tip three times in TE buffer. If the cDNA will be used for another application, the phosphorylation step may not be necessary.

In some applications, second strand synthesis was specifically primed from an adapter added immediately after reverse transcription. According to this approach, after hydrolysis of the mRNA, a partially single-stranded, heteroduplex adapter would be ligated using T4 RNA ligase. The partial double-stranded nature of this adapter would provide a 3'-hydroxyl group from which second strand synthesis could begin, and would prevent concatemerization of the adapter during ligation since T4 RNA ligase cannot ligate double-stranded nucleic acids.

(E) Cleavage From the Support/Recircularization

In certain studies, a vector was ligated to cDNA that had been synthesized on a tip. cDNA or vector:cDNA was cleaved from the solid support in a 40 μ l volume with *AscI* at 37°C in a hybridization oven rotator rack for four hours. 5 Cleaved DNA was then heated to 70°C for 20 minutes with or without mixing. Vector:cDNA was recircularized directly by bringing the volume to 50 μ l with the addition of ligation buffer and T4 DNA ligase. cDNA not previously ligated to vector was split into several aliquots for test ligations to determine which vector:insert ratio gives the best result in subsequent transformations. In this case, since the total amount 10 of cDNA is small (50-120 ng total in 40 μ l volume), the entire ligation must be transformed, making some type of desalting step necessary.

It is possible to cleave more than 90% of the cDNA from a tip in four hours. There appears to be no advantage to increasing the incubation time under these conditions. Increasing enzyme concentration may cut the time necessary for cleavage, 15 but a balance must be struck between incubation time and cleavage volume.

(F) Transformation

cDNA clones were propagated by electroporation transformation of electrocompetent *E. coli* with DNA aliquots from a ligation. Transformation frequencies can vary between 10^9 - 10^{10} cfu per μ g DNA. As those of skill in the art 20 know, the major limitation in this procedure is the salt sensitivity of the electroporation. Only 1-2 μ l of a standard ligation (5-10% of the total volume) can be electroporated per aliquot of electrocompetent cells before the threshold salt tolerance is exceeded and the applied current arcs between the electrodes, vaporizing the cells and wasting the portion of ligation used. Many separate aliquots of cells can be electroporated to keep this 25 from happening, but this is both laborious and wasteful. A better scheme is to use a desalting step that can be added to the current cDNA methodology which is flexible enough to be adapted to an in-line or scaled-down version of the technology without sacrificing yield.

Transformants were plated on standard growth medium, such as LB agar containing antibiotics. Only bacteria harboring the gene for antibiotic resistance form colonies on media containing that antibiotic. Differentiating between true recombinants and colonies containing only vector sequences is often accomplished by blue-white color selection which is a result of the expression of the *lacZ* gene which runs through the multiple cloning sites of many common plasmid vectors. Expression of the *lacZ* gene product is interrupted by an insert ligated into the multiple cloning site resulting in a white colony phenotype. In this scenario, recombinants can be visually identified from non-recombinants, but must either be picked from the non-recombinants or a certain level of background non-recombinants must be tolerated in the final product. Even a relatively low background of non-recombinants can cause problems when the library is amplified since bacteria containing vectors without inserts tend to be faster growing and are more stable than those containing inserts, especially those recombinants with large inserts.

15

EXAMPLE 2:

SCALING DOWN INPUT RNA FOR cDNA SYNTHESIS ON THE SOLID SUPPORT

By minimizing loss of material during the many manipulations involved in standard cDNA library production, it is possible to scale down the input RNA levels by 10-100 fold. For example, roughly 100 ng of double-stranded cDNA can be synthesized on a solid support from 10 μ g total RNA, which is 50-fold less starting material than that called for in commercially available kits. It may be possible to scale this down as much as 10-fold without changing the protocol described above significantly, although this will probably require the addition of an amplification step.

An alternative would be to follow cDNA synthesis through adapter ligation using a T7 promoter-adapter. This would allow the amplification by *in vitro* transcription rather than by PCR, which may produce a more representative library by eliminating length bias inherent in PCR amplifications. *In vitro* synthesized transcripts could then be captured and processed just as any other RNA source. The success of

30

this amplification would rely on careful optimization of the *in vitro* transcription conditions to insure full-length transcripts. Uncaptured transcripts could be polyadenylated using yeast poly(A) polymerase, then captured by adding them back to the same support. Although the re-adenylated transcripts would not be full-length, not
5 all their information would be lost from the RNA pool.

In one study, a T7 promoter-adapter was synthesized and ligated to double-stranded cDNA from 10 µg total RNA on a tip. Using the manufacturer's suggested conditions for *in vitro* transcription, a significant amount of transcripts were produced that ranged in size from 300 base pairs to 2,000 base pairs. Although these
10 sizes are not optimal for an effective amplification step, the study shows that producing *in vitro* transcripts is possible on a solid support.

Another strategy for scale-down is to take advantage of asymmetric (linear) PCR in the same manner as *in vitro* transcripts to amplify and recapture the product. Since the amplified product is DNA rather than RNA, a DNA polymerase can
15 be used to generate double-stranded cDNA.

EXAMPLE 3:

SOLID SUPPORT PROBES

20 Poly(A)+ mRNA from 10 µg total RNA was captured, reverse transcribed, second strand cDNA was synthesized, and a T7 promoter-adapter was ligated to the cDNA. In one study, the solid support was placed in a standard Cetus PCR tube (ABI, Foster City, CA) and cycled for 35 rounds using a long PCR polymerase (Ex-Taq, TAKARA) in a format where the 70°C extension steps were
25 increased in length one minute for every five cycles. Only one primer used in the PCR was complementary to the adapter so that amplification would be primed from the 5'-most end of the bound cDNA's, producing many copies of the (+) strand. After cycling, PCR products were heat denatured and run on an agarose gel to visualize the range of lengths of the single-stranded cDNA. Sizes ranged from roughly 500 base
30 pairs to over 20 kilobase pairs, which was in good agreement with the sizes of double-

stranded cDNAs labelled, cleaved, electrophoresed and visualized by autoradiography in parallel control experiments.

To determine whether or not the single-stranded PCR product was representative of the original mRNA population, PCR primers were designed for several genes known to be present at a high level, low level, or not at all. The design of the primers was such that all products would be approximately the same length (400-600 base pairs) and would be situated at or near the 5'-end of the cDNA. This primer design provided a good approximation of the quality of the first strand synthesis. Since the RNA source was the human Jurkat T-cell line, IL-2, IL-4, GM-CSF, GAPDH, CTLA4, c-fos, and Werner's helicase sequences were used for the primers. Mouse guanylate kinase was used as a negative control.

All polymerase chain reactions produced the expected product size with the exception of CTLA4 and mouse guanylate kinase, as expected. The product for IL-2 was confirmed by Northern blot where 50 ng of the putative IL-2 was ³²P-labelled and hybridized to a blot containing immobilized RNA from both stimulated (PMA + ionomycin) Jurkat and unstimulated Jurkat. After a high stringency wash, the unstimulated RNA showed almost no signal whereas the stimulated sample showed an intense signal consistent with the size expected for IL-2 message.

20

EXAMPLE 4:

USE OF THE SOLID SUPPORT FOR RAPID AMPLIFICATION OF cDNA ENDS

Rapid amplification of cDNA ends, or RACE, is also a technique that is adaptable to the solid support cDNA technology, described herein. Either 5'- or 3'-RACE can be performed after adapter ligation of double-stranded cDNA using the back-end of the capture oligonucleotide (3'-RACE) or the proper 5' adapter oligonucleotide (5'-RACE) as anchors. Solid support RACE offers advantages over currently available techniques since little material is used in generating the cDNA and the product can be re-used. This application would rely on the ability to run a PCR directly on the solid support described above. Initial experiments have shown that this

30

can be done for a high copy number housekeeping gene, GAPDH, and that the end product is directly proportional to the quality of the captured RNA and subsequently synthesized cDNA. Standard methods for performing 3'-RACE and 5'-RACE are well-known to those of skill in the art (*see*, for example, Wu et al., *Methods in Gene*
5 *Biotechnology*, pages 15-28, (CRC Press 1997)).

EXAMPLE 5:

SOLID SUPPORT CDNA SYNTHESIS FOR GENE EXPRESSION ASSAY

(A) Cell Stimulation and RNA Preparation

10 In one set of studies, Jurkat line JRT 3.5 was stimulated for six hours at a cell density of 1×10^6 cells/ml in serum-free RPMI medium (Life Technologies, Gaithersburg, MD) in the presence of 10 ng/ml phorbol-12-myristate-13 acetate (Calbiochem, San Diego, CA) and 100 ng/ml ionomycin (Calbiochem). Cells were pelleted, washed in 1x PBS (Life Technologies), re-pelleted and lysed in 0.5ml per 10^6
15 cells with buffer containing 4 M guanidine isothiocyanate/1% N-lauryl sarcosine/25 mM sodium citrate (pH 7.1) (Fisher Scientific, Pittsburg, PA). One-tenth volume 2 M sodium acetate (pH 4.2) (Fisher Scientific) was added followed by one volume of water-saturated phenol (Amresco, Solon, OH). After mixing, one-fourth volume chloroform:isoamyl alcohol (29:1), (Fisher Scientific) was added, the solution was
20 mixed vigorously, then incubated on ice for 10 minutes. The lysate was then centrifuged, the aqueous phase removed, and extracted with an equal volume of chloroform:isoamyl alcohol. The aqueous phase was then pooled and the RNA precipitated with two volumes of ethanol (Quantum Chemical Corp, Tuscola, IL). After centrifugation, the ethanol was decanted and the RNA was air-dried briefly, then
25 resuspended in RNase-free water to a concentration of between 1 and 5 mg/ml.

(B) Capture and First Strand Synthesis

One solid support bearing the covalently linked oligonucleotide, 5'-ACTACTGATCAGGCGCGCCTTTTTTTTTTTTTTTTTTTTTTTT-3' [SEQ ID NO:1]

(Genset, La Jolla, CA), was added to 10 μ g total cellular RNA, and diluted in sufficient RNase-free water to cover the tip in a sterile 1.5 ml microfuge tube (Fisher Scientific). This oligonucleotide contains a spacer and an *AscI* cleavage site 5' of the Oligo(dT) sequence. The RNA and tip were incubated at 65°C for 5 minutes. An equal volume of 2x mRNA hybridization buffer consisting of 50 mM Tris (pH 7.5), 1 M NaCl (Fisher Scientific) and 20 μ g/ml acetylated-BSA (New England Biolabs, Beverly, MA) was added to each tube, and the tubes rocked gently for two hours at room temperature. The supernatant was removed and the tip was then washed three times in 1x mRNA hybridization buffer. After the final wash was complete, a reverse transcription mix consisting of 1x MMLV-reverse transcriptase buffer, 1 mM dNTP mix, 2 mM DTT (Life Technologies), 20 units RNasin (Promega, Madison, WI) and 10 μ g/ml acetylated-BSA (New England Biolabs) were added to each tube followed by addition of 600 units MMLV-reverse transcriptase (Life Technologies). This reaction was rocked gently at 42°C for two hours. One unit of RNase H (Boehringer-Mannheim, Indianapolis, IN) was then added and the reaction was allowed to continue for another half hour. The supernatant was again removed and each tip was washed three times in 10 mM Tris (pH 8) with 1 mM EDTA (pH 8) (Fisher Scientific). Remaining RNA template was removed by boiling the tips in TE buffer with 0.01% SDS (Fisher Scientific).

20

EXAMPLE 6:

HIGH THROUGH-PUT MELTING PROCEDURE USING THE SOLID SUPPORT

A capture oligonucleotide (36-mer) was covalently linked to a polyethyleneimine-coated nylon pin assembly via a C6-amine tail. Shorter oligonucleotides (18-mer) labeled via a C6 amine tail with Texas Red were hybridized to the capture oligonucleotide in a 1.5 M guanidinium thiocyanate solution for 15 minutes at ambient temperature. The pin assemblies were then washed to remove unhybridized signal oligonucleotide twice with TEN buffer (0.01 M Tris (pH 7.5), 1 mM EDTA, 100 mM NaCl) and then once with TENS buffer (0.01 M Tris (pH 7.5), 1

30

mM EDTA, 100 mM NaCl, 0.1% SDS) followed by two washes with TEN buffer. Test solutions were aliquoted into wells of a polycarbonate thermowell plate (Corning Costar Corp. Cambridge, MA), and the plate was placed in an MJ thermal cycler (MJ Research Company Watertown, MA). The pins were serially transferred between the wells of the plate. Every five minutes the temperature was increased by 5°C, starting at 10°C and reaching 85°C at the final point. The liquid was transferred to a black 96 well microtiter plate and fluorescence was measured.

The level of fluorescence in each well correlates with the amount of signal oligonucleotide that has melted from the capture oligonucleotide. The "melting" or duplex dissociation was conducted over a temperature range of 10°C to 95°C. Fluorescence was measured with a commercial fluorescence plate reader. To calculate the T_d , cumulative counts eluted at each temperature were plotted against temperature. The temperature at which 50% of the material had been dissociated from the tip was taken as the T_d . The helical coil transition is defined as the temperature at which a value of alpha equals 0.2 for a given oligonucleotide duplex (or nucleic acid duplex, containing or not containing a mismatch at any place in the duplex) to the temperature at which a value for alpha equals 0.8 for the same given oligonucleotide duplex (or nucleic acid duplex). The data are exported into a spreadsheet and melt curves are generated for each solution. From these melt curves, T_d , ΔHCT , and ΔT_d are calculated.

In one study using a 1 x 12 Pin assembly, each test solution was placed into 16 separate wells of two thermowell plates (Corning Costar Cambridge, MA) containing 100 ul aliquots, one tube for each temperature point. The pin assembly was transferred to a new row of the plate before each temperature jump. Just before reaching the 50°C temperature point, the first plate was removed from the thermal cycler and replaced with the second thermowell plate. When the thermal cycling program was complete, the liquid was transferred to wells of two black microfluor plates (Dynatech). Fluorescence was measured using excitation wavelength 584 nm and emission wavelength 612 nm. The data were exported to a spreadsheet program for analysis.

In a study using a 4 x 12 Pin Assembly, eight thermowell plates were cut in half to make sixteen 4 x 12 well plates. A 100 μ l aliquot of each test solution was placed into one well of each half-plate until all wells contained test solution. All sixteen half-plates were identical in solution configuration. The pin assembly was transferred to a new half-plate before each temperature jump. When the thermal cycling program was complete, the liquid was transferred to wells of eight black microtiter plates (Dynatech). Fluorescence was measured using excitation wavelength 584 nm and emission wavelength 612 nm. The data were exported to a spreadsheet program for analysis.

10

EXAMPLE 7:

DETERMINATION OF THE MELTING TEMPERATURE OF OLIGONUCLEOTIDE DUPLEXES IN VARIOUS HYBOTROPE AND NON-HYBOTROPE BASED HYBRIDIZATION SOLUTIONS.

This example describes the determination of the T_d of wild type and mutant oligonucleotides when hybridized to a target nucleic acid. It is shown that hybotrope based hybridization solutions allow the detection of single base pair mutations in a nucleic acid target with a probe up to a 30 nucleotides in length.

(A) Solutions and Reagents

The filter wash (FW) was 0.09 M NaCl, 540 mM Tris (pH 7.6), 25 mM EDTA. "SDS/FW" is FW with 0.1% sodium dodecyl sulfate (SDS). Hybridization solutions contained the text specified concentration of hybotrope, 2% N-lauroylsarcosine (sarcosyl), 50 mM Tris (pH 7.6) and 25 mM EDTA. Formamide hybridization solution contained 30% formamide, 0.09 M NaCl, 40 mM Tris-HCl (pH 7.6), 5 mM EDTA, and 0.1% SDS. Guanidinium thiocyanate was purchased from Kodak (Rochester, NY). GuCl, lithium hydroxide, trichloroacetic acid, NaSCN, NaClO₄ and KI, were purchased from Sigma (St. Louis, MO). Rubidium hydroxide was purchased from CFS Chemicals (Columbus, OH). CsTFA was purchased from Pharmacia (Piscataway, NJ).

25

LiTCA and TMAATCA, and TEATCA were prepared by the dropwise titration of a 3 N solution of LiOH, TEAOH and TMAOH respectively, with trichloroacetic acid (100% w/v, 6.1 N) to pH 7.0 on ice with constant stirring. The salt was evaporated to dryness under vacuum, washed once with ether and dried.

5 Oligonucleotides were synthesized on a commercial synthesizer using standard cyanoethyl-N,N-diisopropylamino-phosphoramidite (CED-phosphoramidite) chemistry. Amine tails were incorporated onto the 5'-end using the commercially available N-monomethoxytritylamino-hex-6-yloxy-CED-phosphoramidite. Alternatively, oligonucleotides were commercially purchased (Midland Certified
10 Reagents, Midland, Tx.).

Table I shows the oligonucleotides that were used to measure the difference in T_d between a wild type oligonucleotide and a mutant oligonucleotide. The wild type oligonucleotide represents fully and perfectly base-paired duplex and a mutant oligonucleotide represents a single base pair mismatch (generally in the middle
15 of the oligonucleotide).

Table I

Identity of Oligonucleotide	Nucleotide Sequence	SEQ ID NO.
“capture” oligonucleotide	5'-GTCATACTCCTGCTTGCTGATCCACATCTG-3'	2
wild type 30-mer	5'-CAGATGGGTATCAGCAAGCAGGAGTATGAC-3'	3
mutant 30-mer	5'-CAGATGGGTATCAGGAAGCAGGAGTATGAC-3'	4
wild type 24-mer	5'-ATGGGTATCAGCAAGCAGGAGTAT-3'	5
mutant 24-mer	5'-ATGGGTATCAGGAAGCAGGAGTAT-3'	6
wild type 18-mer	5'-GGTATCAGCAAGCAGGAG-3'	7
mutant 18-mer	5'-GGTATCAGGAAGCAGGAG-3'	8

Oligonucleotides were bound to the tips described herein. In these studies, the oligonucleotides were attached to the tips using the approach described by

Van Ness et al., *Nucl. Acids Res.* 19:3345, 1991. The oligonucleotide-tips contained 0.1 to 1.2 µg/tip of covalently immobilized oligonucleotide.

(B) Solid-phase Hybridization

5 To label the probe oligonucleotides, amine oligonucleotides were reacted with amine-reactive fluorochromes. The derived oligonucleotide preparation was divided into three portions and each portion was reacted with either (a) 20-fold molar excess of Texas Red sulfonyl chloride (Molecular Probes, Eugene, OR), with
10 (b) 20-fold molar excess of Lissamine sulfonyl chloride (Molecular Probes, Eugene, OR), or (c) 20-fold molar excess of fluorescein isothiocyanate. The final reaction conditions consisted of 0.15 M sodium borate (pH 8.3) for one hour at room temperature. The unreacted fluorochromes were removed by size exclusion chromatography on a G-50 Sephadex column.

A high throughput method for the measurement of the thermodynamic
15 properties of oligonucleotide duplexes has been developed. The method allows thousands of solution samples to be scanned for their ability to modulate the thermodynamic parameters of the helical to coil transition of oligonucleotide duplexes. This method employs a solid support which has been designed to fit in a Cetus plate (or the well of a plate designed for 96 well PCR format) and requires about 40 µl of
20 volume to be completely covered by liquid. The design of the tip is shown in Figure 1. This tip is also designed to be compatible with the square end of a spring probe that can be used as an attachment site in order to array the nylon tips in a 1x8, 1x12, 4x8, 4x12, or 8x12 format. A depiction of such a device is shown in Figure 2.

One member of the oligonucleotide duplex is immobilized on the nylon
25 tip as described by Van Ness and Chen, *Nucleic Acids Res.* 19:5143, 1991. A hybridization step is then used to form the oligonucleotide duplexes on a tip. The hybridization step can be performed *en masse* in a single container or individually in the wells of a plate used for the PCR. It is therefore possible for every tip of a 96 member array of tips to possess a different oligonucleotide duplex.

After the hybridization step, the tips are washed and then placed in a PCR plate mounted on a thermocycler. In the case of the 1x8 or 1x12 format, the tips are then moved through a series of wells each time the temperature is increased by 5°C. Typically, the temperature increments are in 5°C steps and the period of the melting at each temperature is 1 to 5 minutes. For example, tips in a 1x12 format are placed in row H at 10°C. The thermocycler is then programmed to ramp through 16 steps at 2 minute intervals with 5°C increments of temperature. The tip array is moved from row to row 15 seconds prior to the temperature increase. In this format, 12 solutions can be studied using two plates of solution. In a 96 tip format, entire plates of solution are moved off and on the thermocycler at the timed interval.

Fluorescent probes are commonly used in this format and have little effect on the measured T_d values described herein. The use of radiolabeled or fluorescent probes permit a wide variety of solutions to be measured since there is no requirement of optical clarity, in contrast to the case for melt curves derived by UV spectrometry (hyperchromicity shifts). Fluorescence is measured with a microtiter plate fluorescence reader, the data are directly imported into a spreadsheet program, such as Excel, which then calculates the stability, enthalpy, helical coil transition, and temperature range, and then graphs the results. Typically, a 1x12 format that measures 12 solutions at once can be completed within one hour, including set up and data reduction.

For the determination of oligonucleotide/oligonucleotide T_d from the oligonucleotide-tip, fluorescently-labeled oligonucleotide is incubated in various hybridization solutions with a complementary oligonucleotide immobilized on oligonucleotide-tips. From 5 to 5000 ng of oligonucleotide are hybridized in 300-400 μ l volumes at various temperatures (19-65°C) for 5 to 30 minutes. The tips are washed three times with one milliliter of the respective hybridization solution, and then once with the respective melting solution at the starting temperature of the melting process. The tips in 100 μ l of the respective melting solution are then placed on top of a thermocycler. At one to five minute intervals, the temperature is raised 5°C, and the tip is moved into a new well of the microtiter plate. The melting, or duplex dissociation, is

conducted over a temperature range of 10°C to 95°C. Fluorescence is measured with a commercial fluorescence plate reader.

To calculate the T_d , cumulative relative fluorescent units (RFUs) eluted at each temperature were plotted against temperature. The temperature at which 50% of the material had been dissociated from the tip is the T_d or T_m . The helical coil transition is defined as the temperature at which a value of a equals 0.2 for a given oligonucleotide duplex (or nucleic acid duplex, containing or not containing a mismatch at any place in the duplex) to the temperature at which a value for a equals 0.8 for the same given oligonucleotide duplex (or nucleic acid duplex).

10 The following T_d s were obtained in the hybridizations described below:

Table II

Solution Type	Length of Probe	T _d (Mutant) (°C)	T _d (Wild Type) (°C)	Δ-T _d (°C)	HCT (°C)
2.5 m LiTCA	30-mer	27	33	6	13/14
2.5 m LiTCA	24-mer	25.5	32	6.5	13/14.5
2.5 m LiTCA	18-mer	24	31	7	9/14
2.0 m LiTCA	30-mer	42	47	5	13.5/16
2.0 m LiTCA	24-mer	38	44	6	14/15
2.0 m LiTCA	18-mer	37	43	6	14.5/16.5
3.0 m GuSCN	30-mer	37	42.5	5.5	13.5/17.5
3.0 m GuSCN	24-mer	34.5	41	6.6	12.5/17
3.0 m GuSCN	18-mer	33.5	40.5	7	14.5/15
3.0 m GuHCl	30-mer	55.5	60	4.5	16/21
3.0 m GuHCl	24-mer	52.5	58	5.5	15/20
3.0 m GuHCl	18-mer	50	57	7	18/20
Rapid Hybe	30-mer	80	80	0	na*
Rapid Hybe	24-mer	80	80	0	na
Rapid Hybe	18-mer	68	70	2	18/23
5x SSC	30-mer	72.5	72.5	0	18/18
5x SSC	24-mer	69	70	1	18/18
5x SSC	18-mer	67	72	5	16/18
Promega QY	30-mer	80	80	0	na
Promega QY	24-mer	80	80	0	na
Promega QY	18-mer	62	65	3	20/23

* na indicates not applicable or too large to accurately determine.

The data indicate that the hybotropic solutions (LiTCA, GuSCN and GuHCl) permit the detection of a single base-pair mismatch in a 24-mer and 30-mer probe, whereas the detection of a single base-pair mismatch in standard hybridization solutions (Rapid Hybe, Promega QY or 5x SSC) was not possible.

A similar experiment was performed for the 24-mers described above in a series of hybridization solutions.

Table III

Hybridization Solution Type	Slope ([..], k)	HCT	$\Delta-T_d$
LiTCA, 3 M	19	8 C	7.5 C
GuSCN, 3 M	13	10	6.0
NaSCN, 3 M	8.5	11	5.5
NaClO ₄ , 3 M	7	12	4.5
KI, 3 M	5	15	3.0
NaCl, 0.165 M	4.5	17.5	1.5
GuCl, 3 M	3.5	18	1.2
CsTFA, 2M	2.5	18	1.2
30% formamide	ND	20	1.5

5 $T_d(\text{wt})$ is the T_d of a perfectly base-paired oligonucleotide duplex and $T_m(\text{mt})$ is the T_d of an oligonucleotide duplex containing a single mismatch. The values shown are for a 24-mer duplex of the sequence described above. From the data presented in Table III, the stringency factor is directly proportional to the difference between a perfectly base paired duplex and a duplex containing a mismatch. That is,
 10 the stringency factor predicts the ability of given hybridization solution to discriminate mismatched duplexes.

Although the foregoing refers to particular preferred embodiments, it will be understood that the present invention is not so limited. It will occur to those of ordinary skill in the art that various modifications may be made to the disclosed
 15 embodiments and that such modifications are intended to be within the scope of the present invention, which is defined by the following claims.

CLAIMS

We claim:

1. A solid-phase sample-retaining tip usable in a procedure for synthesizing or detecting a nucleic acid, comprising:
a tip structure connectable to a support pin; and
a chemical layer coating at least a portion of the tip structure, the chemical layer being bindable to a biomolecule to form a solid-phase sample of the biomolecule on the tip structure.
2. The sample-retaining tip of claim 1 wherein the tip structure is removably connectable to the support pin.
3. The sample-retaining tip of claim 1 wherein the chemical layer is adhered directly to the tip structure.
4. The sample-retaining tip of claim 1 wherein the tip structure has a partially conical shape with a plurality of flutes formed therein.
5. The sample-retaining tip of claim 1 wherein the tip structure has a plurality of heat exchange fins thereon.
6. The sample-retaining tip of claim 5 wherein the tip structure has a partially conical shape.
7. The sample-retaining tip of claim 1 wherein the tip structure has an aperture therein sized to receive the support pin therein, the aperture having a closed end portion and an open end portion, the open end portion having a generally funnel-shape with a decreasing cross-sectional area in the direction of the closed end portion.

8. The sample-retaining tip of claim 1 wherein the tip structure is nylon 6/6.
9. The sample-retaining tip of claim 1 wherein the chemical layer is a polymer having a plurality of amine groups therein that are bindable to the biomolecule.
10. The sample-retaining tip of claim 1 wherein the chemical layer is a poly(ethyleneimine) layer.
11. The sample-retaining tip of claim 1 wherein the selected chemical layer is covalently bonded to the tip structure.
12. A solid-phase sample-retaining assembly for use in a solid-phase procedure for synthesizing or detecting a nucleic acid, comprising:
 - a support pin;
 - a tip structure connected to the support pin; and
 - a chemical layer coating at least a portion of the tip structure, the chemical layer being bindable to a biomolecule to form a solid-phase sample of the biomolecule on the tip.
13. The assembly of claim 12 wherein the support pin is a spring pin.
14. The assembly of claim 12 wherein the tip structure is removably connected to the support pin.
15. The assembly of claim 12 wherein the tip structure is a nylon 6/6 member.
16. The assembly of claim 12 wherein the tip structure has a partially conical shape with a plurality of flutes therein.

17. The assembly of claim 12 wherein the tip structure has a plurality of heat exchange fins thereon.

18. The assembly of claim 12 wherein the chemical layer is a polymer having a plurality of amine groups therein that are bindable to the biomolecule.

19. The assembly of claim 12 wherein the chemical layer is a poly(ethyleneimine) layer.

20. The assembly of claim 12 wherein the tip structure has a dimpled surface to provide an increased surface area of the tip structure.

21. The assembly of claim 12 wherein a first end portion of the support pin has corner portions and a generally polygonal cross sectional shape, the tip structure has an aperture therein defined by a sidewall and having a generally circular cross-sectional area, the corner portions frictionally engaging the sidewall to retain the tip structure on the support pin.

22. The assembly of claim 12 wherein the tip structure has an aperture therein that removably receives the a first end portion of the support pin therein, the aperture having a closed end portion and an open end portion, the open end portion having a generally funnel-shape with a decreasing cross-sectional area in the direction of the closed end portion.

23. An array of solid-phase sample-retaining assemblies for use in a procedure for synthesizing or detecting a nucleic acid, comprising:

a base;

a plurality of support pins connected to the base in an selected array, each support pin having an end portion spaced apart from the base;

a plurality of tip structures connected to the end portions of the support pins;

and

a chemical layer coating at least a portion of each tip structure, the chemical layer being bindable to a biomolecule to form a solid-phase sample of the biomolecule.

24. The array of claim 23 wherein the support pins are spring pins.
25. The array of claim 23 wherein the tip structures are removably connected to the support pins.
26. The array of claim 23 wherein the tip structures are nylon 6/6 members.
27. The array of claim 23 wherein each tip structure has a partially conical shape with a plurality of flutes therein.
28. The array of claim 23 wherein each tip structure has a plurality of heat exchange fins thereon.
29. The array of claim 23 wherein the chemical layer is a polymer having a plurality of amine groups therein.
30. The array of claim 23 wherein the chemical layer is a poly(ethyleneimine) layer.
31. The array of claim 23 wherein the tip structures have a dimpled surface thereon.
32. The array of claim 23 wherein each tip structure has an aperture therein that removably receives a respective support pin's end portion, the aperture having a closed end portion and an open end portion, the open end portion having a generally funnel-shape with a decreasing cross-sectional area in the direction of the closed end portion.

33. A solid-phase sample-retaining assembly and microtiter plate combination for use in a procedure for synthesizing or detecting a nucleic acid, comprising:

a microtiter plate having a well shaped to contain a volume of a sample having a biomolecule therein; and

a solid-phase sample-retaining assembly sized to extend at least partially into the well, the solid-phase sample-retaining assembly including:

a support pin;

a tip structure connected to the support pin, the tip structure being removably positionable in the well; and

a chemical layer coating at least a portion of the tip structure, the chemical layer being bindable to the biomolecule in the solution to form a solid-phase sample of the biomolecule.

34. The combination of claim 33 wherein the support pin is a spring pin.

35. The combination of claim 33 wherein the tip structure is removably connected to the support pin and positionable in the well when the tip structure is removed from the support pin.

36. The combination of claim 33 wherein the tip structure is a nylon 6/6 member.

37. The combination of claim 33 wherein the tip structure has a cross-sectional shape that closely corresponds to a cross-sectional shape of the well.

38. The combination of claim 33 wherein the tip structure has a partially conical shape with a plurality of flutes therein.

39. The combination of claim 33 wherein the chemical layer is a polymer coating with a plurality of amine groups therein.

40. The combination of claim 33 wherein the chemical layer is a poly(ethyleneimine) layer.

41. The combination of claim 33 wherein the tip structure is frictionally retained on the support pin.

42. The combination of claim 33 wherein the microtiter plate has a plurality of wells therein, and further comprising a plurality of the support pins arranged in a selected array, and a plurality of the tip structures connected to a respective one of the support pins to form an array of solid-phase sample-retaining tips positionable into the wells.

43. The combination of claim 42, further including a base connected to ends of the support pins spaced apart from the tip structures and the tip structures are substantially coplanar.

44. A solid-phase sample-retaining tip and microtiter plate combination for use in a procedure for synthesizing or detecting a nucleic acid, comprising:

a microtiter plate having a well shaped to contain a volume of a sample having a biomolecule therein; and

a solid-phase sample-retaining tip removably positioned within the well, the tip having a tip structure that is connectable to the support pin while the tip structure is in the well, and a chemical layer coating at least a portion of the tip structure, the chemical layer being bindable to the biomolecule in the solution to form a solid-phase sample of the biomolecule on the tip.

45. The combination of claim 44 wherein the tip structure is a nylon 6/6 member.

46. The combination of claim 44 wherein the tip structure has a cross-sectional shape that substantially corresponds to a cross sectional shape of the well.

47. The combination of claim 44 wherein the tip structure and the well have partially conical cross-sectional shapes.

48. The combination of claim 44 wherein the tip structure has a partially conical shape with a plurality of flutes therein.

49. The combination of claim 44 wherein the chemical layer is a poly(ethyleneimine) layer.

50. A method of manufacturing a solid-phase sample-retaining tip for use in solid-phase molecular biology processes, comprising the steps of:

forming a substrate material as a tip structure that is attachable to a support pin;

coating at least a portion of the substrate material with a chemical layer that is bondable to a selected biomolecule to form a solid-phase sample of the biomolecule; and
attaching the chemical layer to the substrate material.

51. The method of claim 50 wherein the step of attaching the chemical layer to the substrate material includes covalently attaching the chemical layer to the substrate material.

52. The method of claim 50 wherein the chemical layer is a polymer having a plurality of amine groups therein that are bindable to the biomolecule, and the step of attaching includes covalently attaching the polymer to the substrate material.

53. The method of claim 50 wherein chemical layer is a poly(ethyleneimine) and the substrate material is a nylon 6/6 material, and the step of attaching includes covalently attaching the poly(ethyleneimine) to the nylon 6/6.

54. The method of claim 50, further comprising the step of attaching the tip structure to support pin.

55. The method of claim 54 wherein the step of attaching the tip structure includes removably attaching the tip structure to an end of the support pin.

56. The method of claim 50, further comprising the step of providing a base, a plurality of support pins and a plurality of the tip structures with the chemical layer thereon, attaching the support pins to the base in an array, and attaching the tip structures to a respective one of a plurality of support pins to form an array of solid-phase sample-retaining tips that are spaced apart from the base.

57. A method of forming a solid-phase sample of a biomolecule, comprising the steps of:

immersing a portion of a tip assembly into a solution having the biomolecule therein, the tip assembly having a substrate portion and a chemical layer on the substrate portion, the chemical layer being bindable to the biomolecule;

allowing the biomolecule to bind to the chemical layer to form a solid-phase sample of the biomolecule on the tip assembly; and

removing the tip assembly from the solution after the biomolecule has bonded to the chemical layer.

58. The method of claim 57 wherein the solution is contained in a well of a microtiter plate, and the step of immersing includes positioning a portion of the tip assembly in the well.

59. The method of claim 57, further including the steps of performing a molecular biology process on the tip assembly after the biomolecule has bonded to the chemical layer.

60. The method of claim 57, further comprising the step of storing the solid-phase tip assembly in a retaining member after the biomolecule has bonded to the chemical layer.

61. The method of claim 60, wherein the retaining member is a microtiter plate having a well therein, and the step of storing include placing the tip assembly in the well after the biomolecule has bonded to the chemical layer, and placing the microtiter plate and tip assembly as a unit in a storage location.

62. The method of claim 57, wherein said biomolecule is either a nucleic acid or a polymer of amino acids.

63. The method of claim 62, wherein said nucleic acid is an oligonucleotide having one end bound to said chemical layer and one free end.

64. The method of claim 63, wherein said oligonucleotide free end comprises an oligo(dT) sequence.

65. The method of claim 64, further comprising the step of binding poly(A⁺) RNA to said tip assembly, wherein the poly(A⁺) portion of said poly(A⁺) RNA is bound to said oligonucleotide oligo(dT) sequence.

66. The method of claim 65, further comprising the step of synthesizing cDNA from said bound poly(A⁺) RNA.

67. The method of claim 57, wherein said biomolecule is an avidin molecule.

68. The method of claim 67, further comprising the step of binding an oligonucleotide to said tip assembly, wherein said oligonucleotide comprises at least one biotin moiety, and wherein said biotinylated oligonucleotide binds to said avidin molecule.

69. The method of claim 59, wherein said molecular biology process is selected from the group consisting of cDNA synthesis, polymerase chain reaction, preparation of a subtracted cDNA library, synthesis of differential probes, solid-phase minisequencing, oligonucleotide ligation assay, and amplified fragment length polymorphism analysis.

70. The method of claim 62, wherein said amino acid polymer is an antibody.

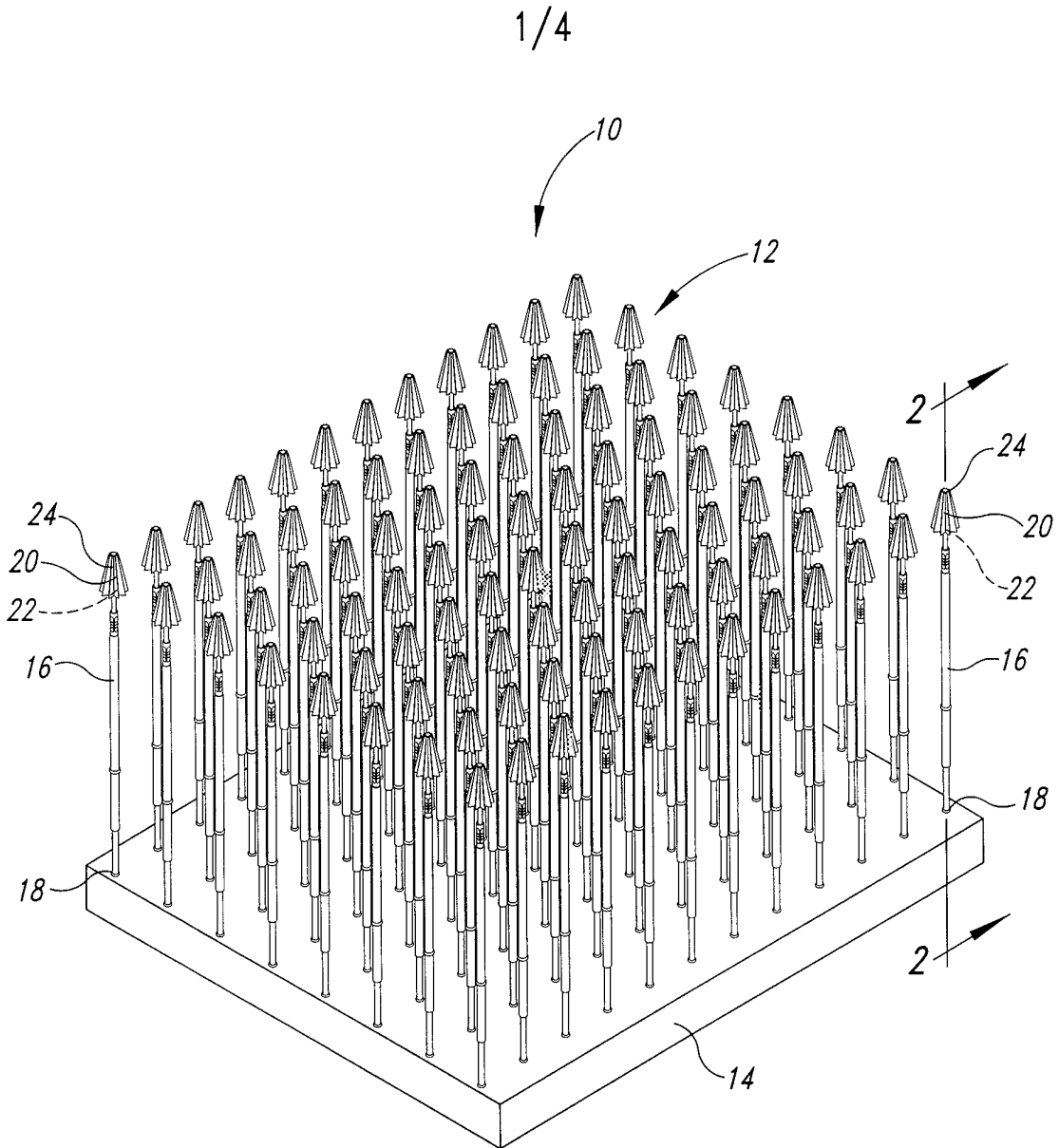

Fig. 1

2/4

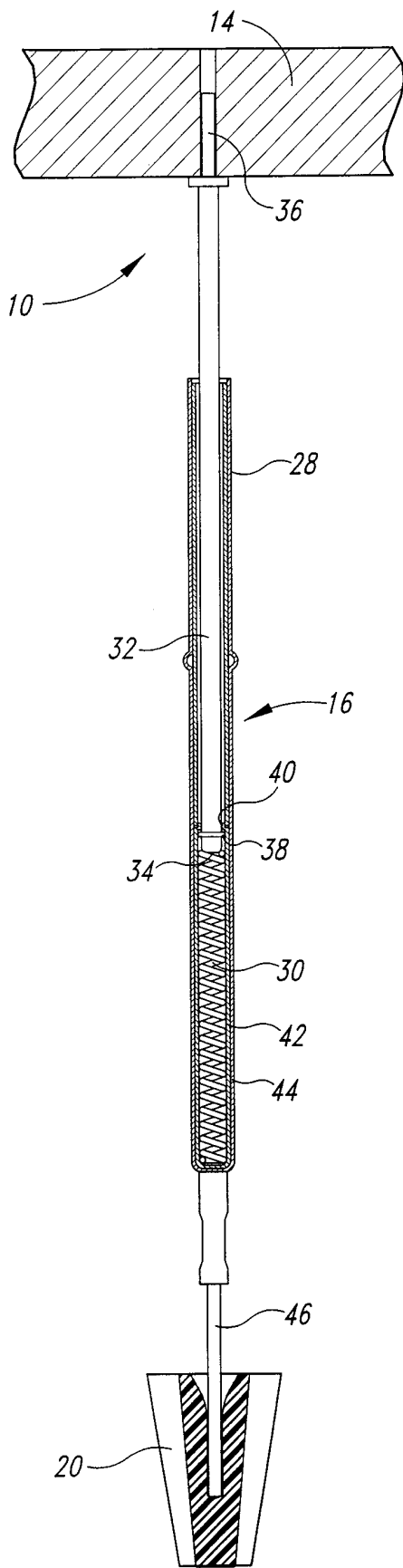

Fig. 2A

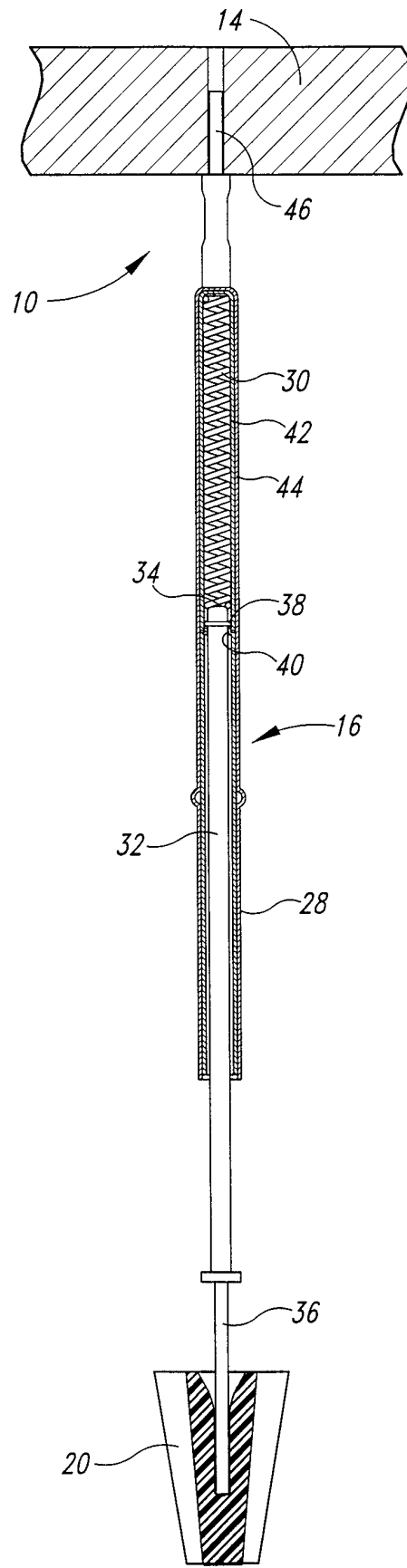

Fig. 2B

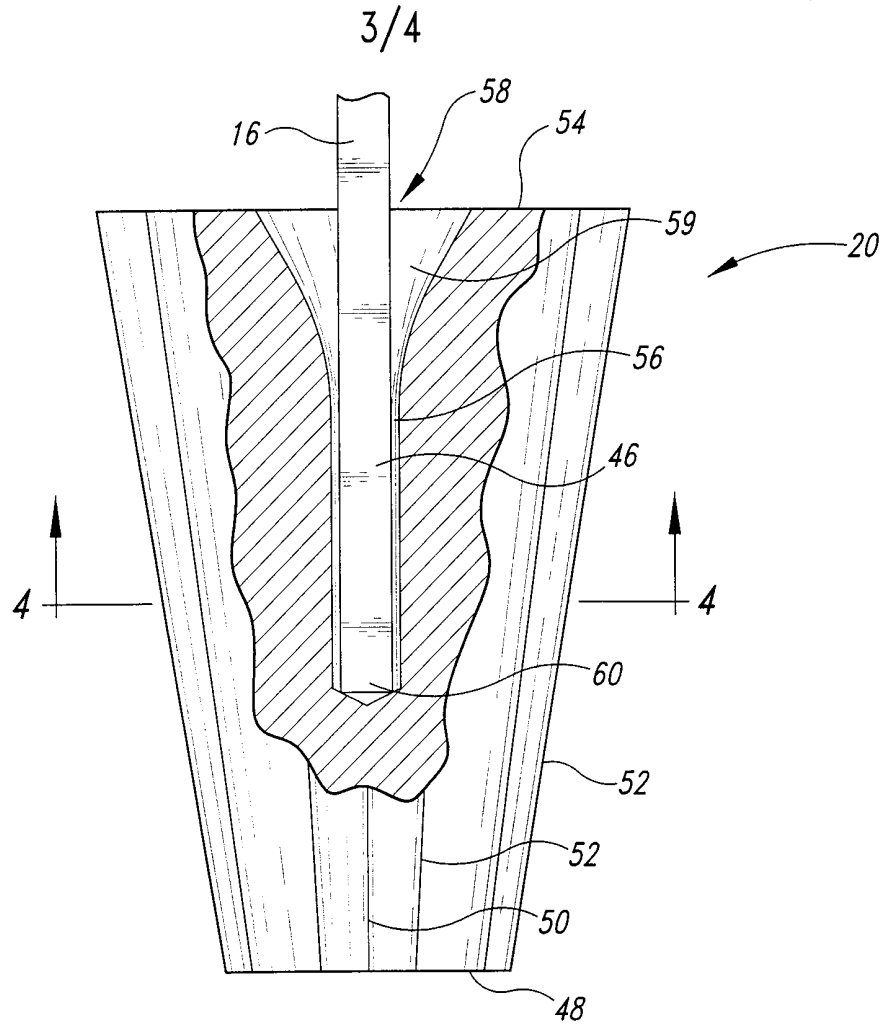

Fig. 3

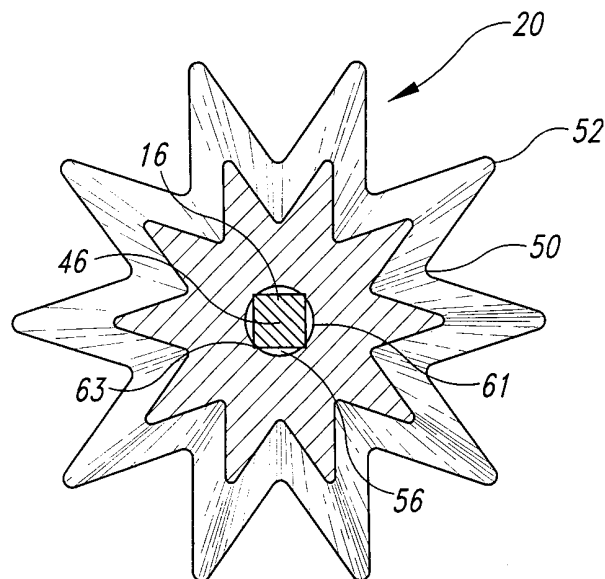

Fig. 4

4/4

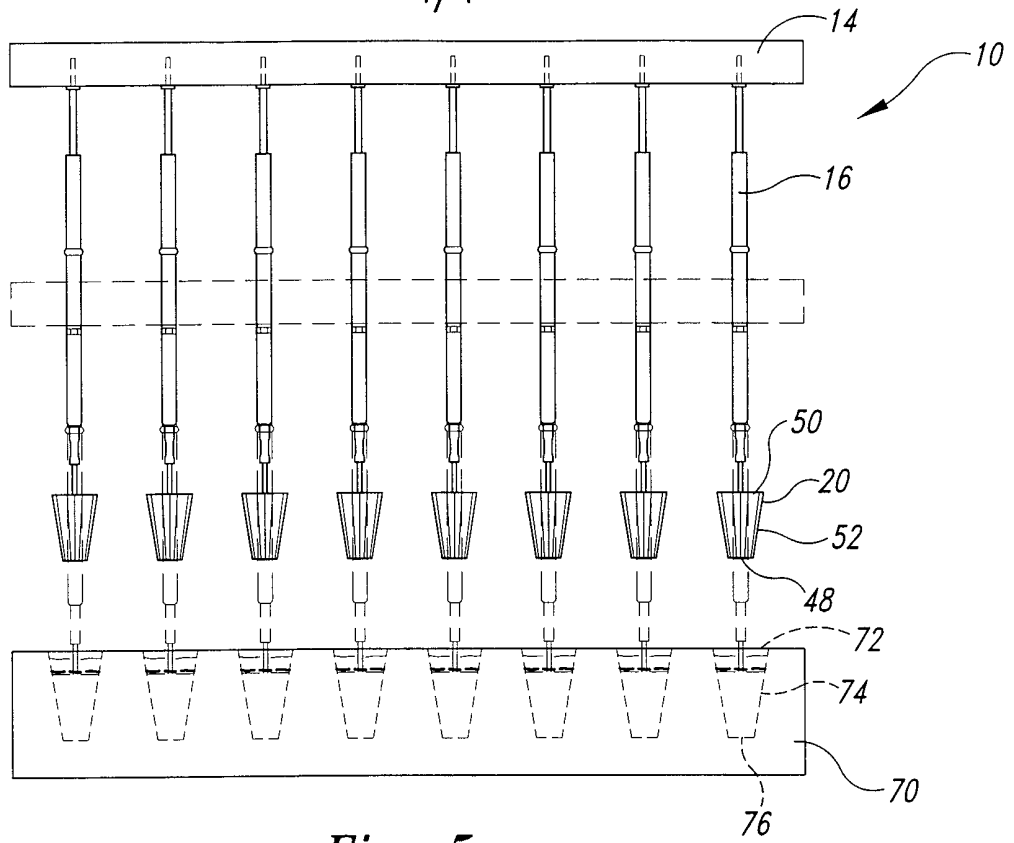

Fig. 5

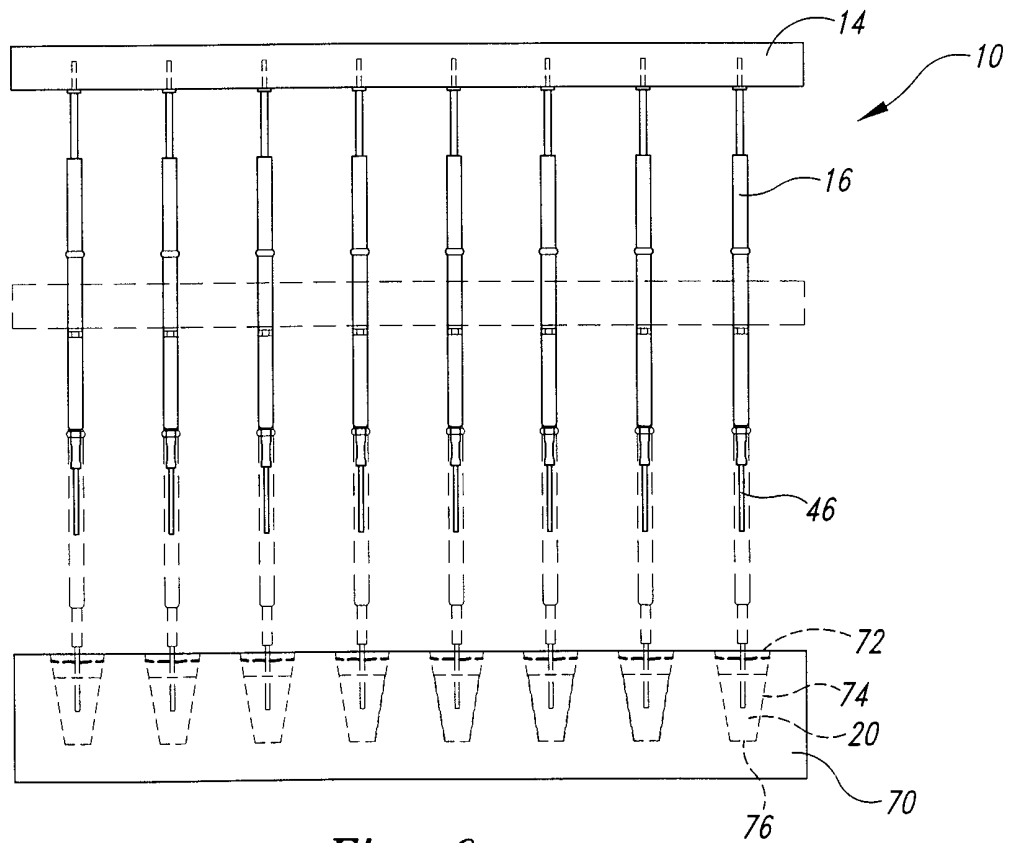

Fig. 6

SEQUENCE LISTING

<110> Rapigene, Incorporated
Garrison, Lori K.
Tabone, John C.
Van Ness, Jeffrey

<120> SOLID-PHASE TIPS AND USES RELATING THERETO

<130> 780068.430PC

<140> PCT

<141> 1998-12-29

<160> 10

<170> PatentIn Ver. 2.0

<210> 1

<211> 39

<212> DNA

<213> Artificial Sequence

<220>

<223> Description of Artificial Sequence:
Oligonucleotide for capture and first strand
synthesis used in gene expression assay

<400> 1

actactgatc aggcgcgcct tttttttttt tttttttttt

39

<210> 2

<211> 30

<212> DNA

<213> Artificial Sequence

<220>

<223> Description of Artificial Sequence:
Oligonucleotide used to measure the difference in
temperature at which half of the molecules of
nucleic acid duplex are single stranded for wild
type and mutant oligonucleotides

<400> 2

gtcataactcc tgcttgctga tccacatctg

30

<210> 3

<211> 30

<212> DNA

<213> Artificial Sequence

<220>

<223> Description of Artificial Sequence:
Oligonucleotide used to measure the difference in
temperature at which half of the molecules of

nucleic acid duplex are single stranded for wild type and mutant oligonucleotides

- <400> 3
cagatgggta tcagcaagca ggagtatgac 30
- <210> 4
<211> 30
<212> DNA
<213> Artificial Sequence
- <220>
<223> Description of Artificial Sequence:
Oligonucleotide used to measure the difference in temperature at which half of the molecules of nucleic acid duplex are single stranded for wild type and mutant oligonucleotides
- <400> 4
cagatgggta tcaggaagca ggagtatgac 30
- <210> 5
<211> 24
<212> DNA
<213> Artificial Sequence
- <220>
<223> Description of Artificial Sequence:
Oligonucleotide used to measure the difference in temperature at which half of the molecules of nucleic acid duplex are single stranded for wild type and mutant oligonucleotides
- <400> 5
atgggtatca gcaagcagga gtat 24
- <210> 6
<211> 24
<212> DNA
<213> Artificial Sequence
- <220>
<223> Description of Artificial Sequence:
Oligonucleotide used to measure the difference in temperature at which half of the molecules of nucleic acid duplex are single stranded for wild type and mutant oligonucleotides
- <400> 6
atgggtatca ggaagcagga gtat 24
- <210> 7
<211> 18
<212> DNA
<213> Artificial Sequence

<220>

<223> Description of Artificial Sequence:

Oligonucleotide used to measure the difference in temperature at which half of the molecules of nucleic acid duplex are single stranded for wild type and mutant oligonucleotides

<400> 7

ggtatcagca agcaggag

18

<210> 8

<211> 18

<212> DNA

<213> Artificial Sequence

<220>

<223> Description of Artificial Sequence:

Oligonucleotide used to measure the difference in temperature at which half of the molecules of nucleic acid duplex are single stranded for wild type and mutant oligonucleotides

<400> 8

ggtatcagga agcaggag

18

<210> 9

<211> 30

<212> DNA

<213> Artificial Sequence

<220>

<223> Description of Artificial Sequence: Immobilized oligonucleotide of the reference oligonucleotide representing a nucleic acid duplex

<400> 9

gtcataactcc tgcttgctga tccacatctg

30

<210> 10

<211> 24

<212> DNA

<213> Artificial Sequence

<220>

<223> Description of Artificial Sequence: Solution oligonucleotide of the reference oligonucleotide representing a nucleic acid duplex

<400> 10

tgtggatcag caagcaggag tatg

24

INTERNATIONAL SEARCH REPORT

International Application No
PCT/US 98/27850

A. CLASSIFICATION OF SUBJECT MATTER
 IPC 6 G01N33/543 G01N33/53 C12Q1/68 B01J19/00

According to International Patent Classification (IPC) or to both national classification and IPC

B. FIELDS SEARCHED
 Minimum documentation searched (classification system followed by classification symbols)
 IPC 6 G01N C12Q C07K B01J

Documentation searched other than minimum documentation to the extent that such documents are included in the fields searched

Electronic data base consulted during the international search (name of data base and, where practical, search terms used)

C. DOCUMENTS CONSIDERED TO BE RELEVANT

Category °	Citation of document, with indication, where appropriate, of the relevant passages	Relevant to claim No.
E	WO 99 05308 A (TABONE JOHN C ;RAPIGENE INC (US); MOYNIHAN KRISTEN (US); NESS JEFF) 4 February 1999 see the whole document ---	1-70
E	WO 99 04896 A (TABONE JOHN C ;RAPIGENE INC (US); MOYNIHAN KRISTEN (US); NESS JEFF) 4 February 1999 see the whole document ---	1-70
E	DE 197 42 227 A (WOLFRUM JUERGEN PROF DIPL PHYS) 1 April 1999 see claims see figures 1-3 ---	1-70
-/--		

Further documents are listed in the continuation of box C. Patent family members are listed in annex.

° Special categories of cited documents :

<p>"A" document defining the general state of the art which is not considered to be of particular relevance</p> <p>"E" earlier document but published on or after the international filing date</p> <p>"L" document which may throw doubts on priority claim(s) or which is cited to establish the publication date of another citation or other special reason (as specified)</p> <p>"O" document referring to an oral disclosure, use, exhibition or other means</p> <p>"P" document published prior to the international filing date but later than the priority date claimed</p>	<p>"T" later document published after the international filing date or priority date and not in conflict with the application but cited to understand the principle or theory underlying the invention</p> <p>"X" document of particular relevance; the claimed invention cannot be considered novel or cannot be considered to involve an inventive step when the document is taken alone</p> <p>"Y" document of particular relevance; the claimed invention cannot be considered to involve an inventive step when the document is combined with one or more other such documents, such combination being obvious to a person skilled in the art.</p> <p>"&" document member of the same patent family</p>
--	--

Date of the actual completion of the international search 15 June 1999	Date of mailing of the international search report 22/06/1999
--	---

Name and mailing address of the ISA European Patent Office, P.B. 5818 Patentlaan 2 NL - 2280 HV Rijswijk Tel. (+31-70) 340-2040, Tx. 31 651 epo nl, Fax: (+31-70) 340-3016	Authorized officer Routledge, B
--	---

2

INTERNATIONAL SEARCH REPORT

International Application No
PCT/US 98/27850

C.(Continuation) DOCUMENTS CONSIDERED TO BE RELEVANT		
Category °	Citation of document, with indication, where appropriate, of the relevant passages	Relevant to claim No.
P,X	<p>WO 98 14271 A (CHRISTOPHER ANTHONY ET AL) 9 April 1998</p> <p>see claims see figures 1-7 see page 5, paragraph 2 - page 6, paragraph 2</p> <p align="center">---</p>	<p>1-3,7, 11,12, 14, 21-23, 25,32, 33,35, 41-44, 46, 50-52, 54-59, 62-70</p>
X	<p>WO 94 11388 A (CHIRON MIMOTOPES PTY LTD) 26 May 1994</p> <p align="center">---</p>	<p>1-6, 9-12,14, 16-21, 23,25, 27-31, 33,35, 37-44, 46-52, 54-59, 62,70</p>
Y	<p>see claims see page 2, line 13 - line 17 see page 7, line 7 - page 9, line 2 see page 9, line 25 - page 10, line 7 see figures 1,2</p> <p align="center">---</p>	<p>1-70</p>
X	<p>WO 91 04266 A (COSELCO MIMOTOPES PTY LTD) 4 April 1991</p> <p align="center">---</p>	<p>1-6, 9-12,14, 16-20, 23-25, 27-31, 33,35, 37-44, 46-59, 62,70</p>
Y	<p>see the whole document</p> <p align="center">---</p>	<p>1-70</p>
X	<p>US 5 250 613 A (BERGSTROM KARIN ET AL) 5 October 1993</p> <p align="center">---</p>	<p>1,9-12, 18,19, 23,29, 30,33, 39,40, 44, 49-53,57</p>
Y	<p>see claims see column 3, line 15 - line 49 see column 7, line 41 - line 68</p> <p align="center">---</p>	<p>1-70</p>
	-/--	

INTERNATIONAL SEARCH REPORT

International Application No
PCT/US 98/27850

C.(Continuation) DOCUMENTS CONSIDERED TO BE RELEVANT		
Category °	Citation of document, with indication, where appropriate, of the relevant passages	Relevant to claim No.
X	GB 2 197 720 A (NAT RES DEV) 25 May 1988	1,9-12, 18,19, 23,29, 30,33, 39,40, 44, 49-53,57
Y	see claims see page 2, line 25 - line 30 see page 5, line 16 - page 6, line 9 -----	1-70
Y	AVAILABLE FROM INTERNET, 17-03-97 http://chroma.mbt.washington.edu/mod_www/hamilton.html , Modular Array Head. and AVAILABLE FROM INTERNET, 19-11-98 http://chroma.mbt.washington.edu/mod_www/array.html . Hamilton Microlab Arrayer XP002085223	1-70
P,X	see page 1; figure -----	1-70

INTERNATIONAL SEARCH REPORT

...formation on patent family members

International Application No

PCT/US 98/27850

Patent document cited in search report	Publication date	Patent family member(s)	Publication date
WO 9905308 A	04-02-1999	AU 8504598 A	16-02-1999
WO 9904896 A	04-02-1999	AU 8582598 A	16-02-1999
DE 19742227 A	01-04-1999	WO 9915543 A	01-04-1999
WO 9814271 A	09-04-1998	AU 4802597 A	24-04-1998
WO 9411388 A	26-05-1994	AU 2280697 A	28-08-1997
		AU 680450 B	31-07-1997
		AU 5331594 A	08-06-1994
		CA 2148591 A	26-05-1994
		EP 0672049 A	20-09-1995
		HU 73150 A	28-06-1996
		JP 8505604 T	18-06-1996
WO 9104266 A	04-04-1991	AT 172982 T	15-11-1998
		AU 6359390 A	18-04-1991
		DE 69032745 D	10-12-1998
		DE 69032745 T	01-04-1999
		EP 0498801 A	19-08-1992
US 5250613 A	05-10-1993	SE 467308 B	29-06-1992
		AU 8747991 A	20-05-1992
		EP 0554318 A	11-08-1993
		JP 6502156 T	10-03-1994
		SE 9003363 A	23-04-1992
		WO 9207006 A	30-04-1992
GB 2197720 A	25-05-1988	NONE	