

(No Model.)

3 Sheets—Sheet 1.

A. G. BAKER.
CHARACTERING MACHINE.

No. 425,725.

Patented Apr. 15, 1890.

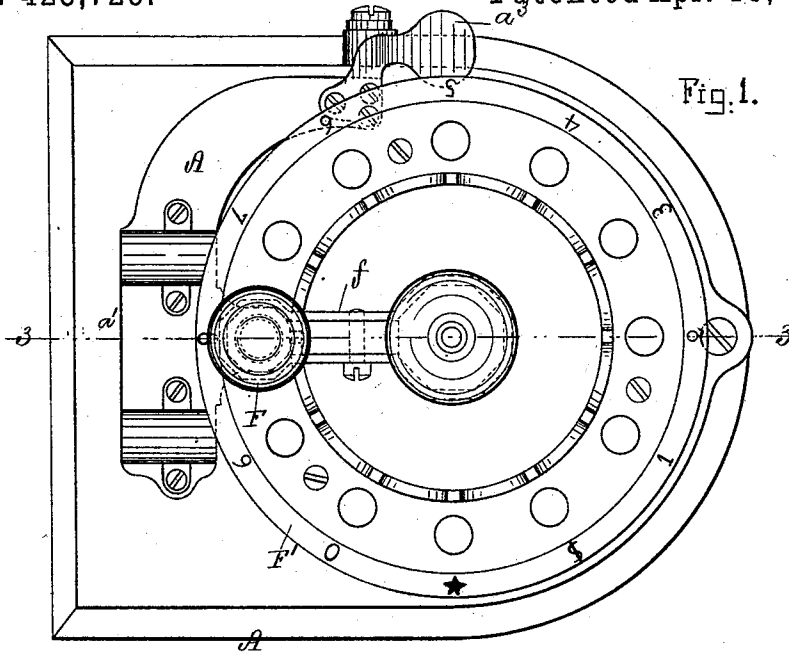

Fig. 1.

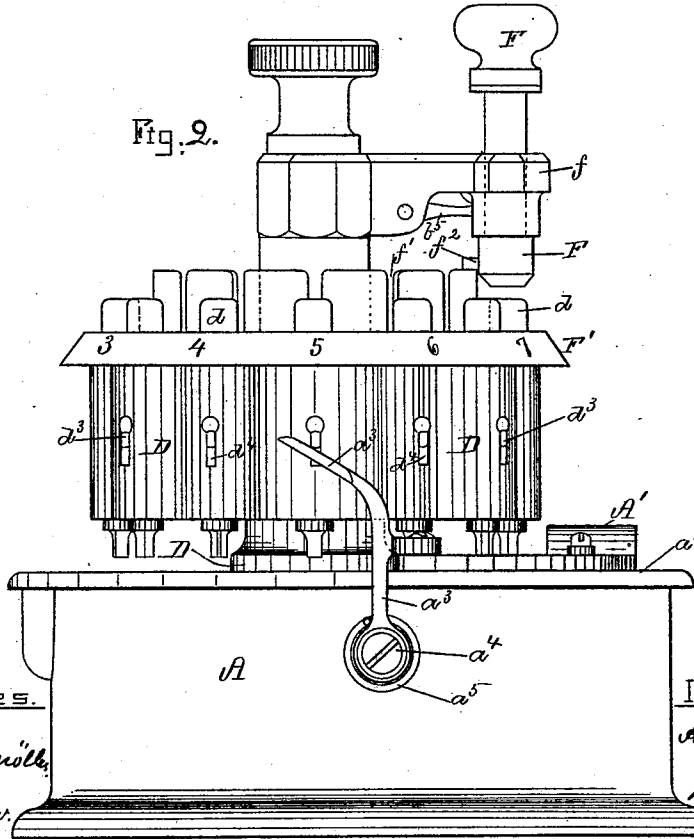

Fig. 2.

Witnesses.

Lauritz to Müller
John R. Knowlton

Inventor.

Amel G. Baker
by his attorneys,
Wheeler & Deane

(No Model.)

3 Sheets—Sheet 2.

A. G. BAKER.
CHARACTERING MACHINE.

No. 425,725.

Patented Apr. 15, 1890.

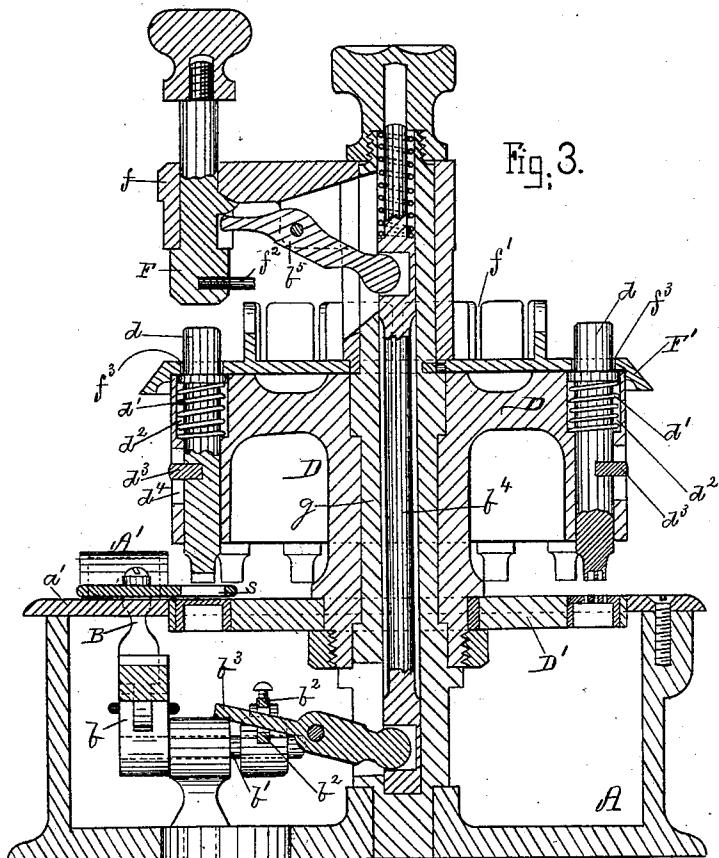
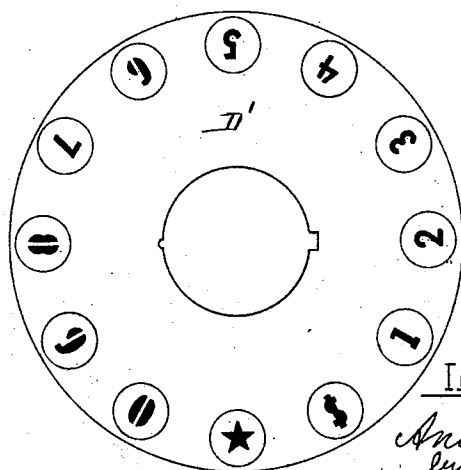

Fig. 4.



Witnesses.

Lawrence W. Proctor
John R. Snow

Inventor.

Amos G. Baker
by his attorneys
Mcquadin & Beach

A. G. BAKER.
CHARACTERING MACHINE.

No. 425,725.

Patented Apr. 15, 1890.

Fig. 5.

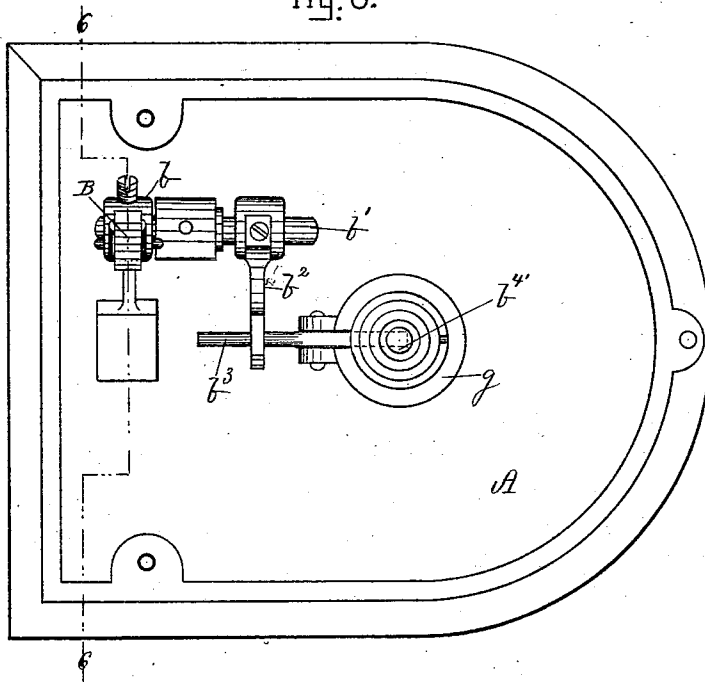
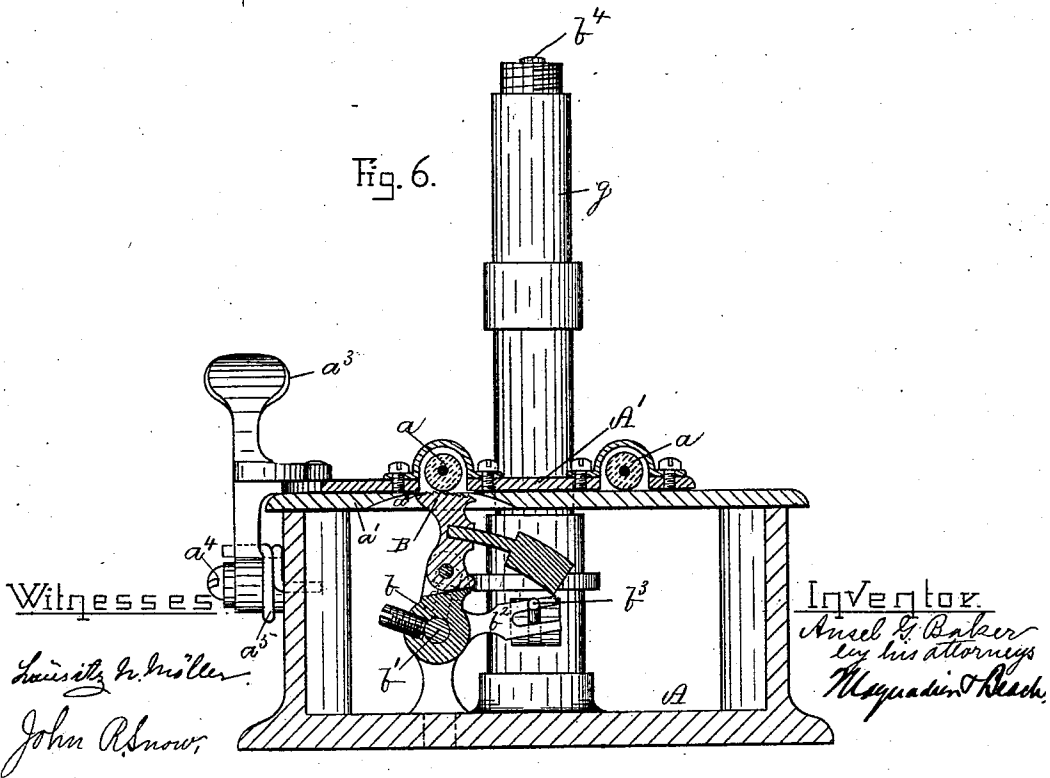

Fig. 6.



UNITED STATES PATENT OFFICE.

ANSEL G. BAKER, OF NEW BEDFORD, MASSACHUSETTS, ASSIGNOR, OF ONE-HALF TO FREDERICK S. GIFFORD, OF SAME PLACE.

CHARACTERING-MACHINE.

SPECIFICATION forming part of Letters Patent No. 425,725, dated April 15, 1890.

Application filed August 28, 1889. Serial No. 322,263. (No model.)

To all whom it may concern:

Be it known that I, ANSEL G. BAKER, of New Bedford, in the county of Bristol and State of Massachusetts, have invented a new and useful Charactering-Machine, of which the following is a specification, reference being had to the accompanying drawings, in which—

Figure 1 is a plan of a machine embodying my invention; Fig. 2, a side elevation of the same; Fig. 3, a vertical section on line 3 3 of Fig. 1. Fig. 4 is a plan view of a female die-plate. Fig. 5 is a plan of the machine with parts removed to show mechanism within the base for actuating the feed, showing, also, the tubular support for the impression-bar carrier. Fig. 6 is an elevation, partly in section, on line 6 6 of Fig. 5.

The chief object of my invention is to produce an improved machine for use in putting characters on sheet material, as by punching, embossing, or printing the desired characters.

The machine in which my invention is here shown embodied is a machine adapted to punch characters in bank-checks, certificates of stock, and the like.

My invention may, however, be embodied in machines for various other uses, as will be plain to all skilled in the art.

My invention consists, chiefly, in a positive work-feed and guide-rolls combined together to accurately feed and guide the work under the impression-bars, and in a rotary support carrying a series of impression-bars combined with a single key and a guide-frame, which causes the key to register accurately with the impression-bars.

Other features of my invention will be set forth hereinafter.

In the drawings, in which I show my invention embodied in one of several forms which I have contemplated, but which is, on the whole, the best form now known to me, A is the base; B, one form of work-feed; D, a carrier for the impression-bars, and F a key to operate the impression-bars mounted in the carrier. Hitherto machines of this class have been provided with work-feeds which have not fed the work positively the necessary distance to insure the proper space be-

tween the characters. In order to obviate this objection, I provide a positive feed, which is conveniently formed of an oscillating bar B, roughened at its outer end and projecting against the work through the opening a^4 in the work-support a' . The feed is connected to the key F in such wise that the work is fed by the movement of the key, depression of key F in this form of my machine carrying the feed B out of contact with the work, and the opposite motion of the key causing the feed to operate. The positive feed B and key F are conveniently connected by rocker-arm b , fast on rocker-shaft b' , mounted in a bracket on base A, rocker-arm b^2 , fast on rocker-shaft b' , lever b^3 , connected to spindle b^4 , playing in the hollow shaft g of carrier D, and lever b^5 , connecting spindle b^4 to key F. When key F is moved away from the impression-bars, the spindle b^4 is moved inwardly and feed F actuated to feed the work. The feed is moved back to its inoperative position, say, by means of a weight, a weight being, I think, much better than a spring for this purpose, because the weight acts more rapidly and positively, as will be understood by all skilled in the art. The presser-foot A' holds the work on the work-support and supports rolls a , which guide the work and keep it straight as it is fed along by the feed B. Presser-foot A' is best formed with a sight-hole s and a thumb-piece a^3 , and rocks on pin a^4 , a spring a^5 being used to keep it in place on the work.

Key F is mounted in a stationary bracket f and is caused to accurately register with an impression-bar by guide-frame F' , which is best formed, as shown, with slots f' , in which projection f^2 on the key plays when the key moves. The ends of the impression-bars d , in this form of my machine, project through openings f^3 in frame F' , and are sustained by springs d' , mounted in the bar-containing chambers d^2 in the carrier D. Bars d , if formed with rounded shanks, as shown, are best provided with projections d^3 , playing in recesses d^4 in the walls of the containing-chambers d^2 . The impression-bars, of course, are provided with characters—in this case, female dies. When male dies are used, the female die-plate D' is desirable. The guide-

frame F' in the present construction bears
 characters corresponding to the characters on
 the impression-bars, and the carrier D, female
 die-plate D', and guide-frame F' rotate to-
 5 gether between the key and sight-hole in the
 presser-foot. When the desired impression-
 bar is brought into place to give its impres-
 sion, the key is depressed, and while it is en-
 10 gaged with the slots in the guide-frame the
 key and impression-bar are kept in fixed rela-
 tion to each other, so that depression of the
 key causes the impression-bar to move against
 the work—in this case through the sight-hole
 15 s. The key cannot enter a slot in the guide-
 frame until an impression-bar is over the im-
 pression-point, (or, in the present construc-
 tion, in which the presser-foot is formed with
 a sight-hole s,) is over the sight-hole, because
 20 the key is mounted in the fixed bracket, which
 has a fixed relation to the impression-point,
 as explained above. The ears formed by the
 slots in the guide-frame are best rounded off,
 so that the key when depressed will the more
 25 readily enter the slot. This combination of
 the guide-frame with the impression-bars and
 the key mounted in a bracket having a fixed re-
 lation to the impression-point is an important
 feature of my invention.

Another important feature of my invention
 is the combination of the feed and key 30
 through the hollow shaft of the carrier, be-
 cause it results in compactness and simplicity
 of construction. Of course other than the
 positive feed shown may be employed in this
 combination without departing from the spirit 35
 of this feature of my invention, which is to
 combine with any sort of feed a single key
 and rotary impression-bar carrier, the key
 and feed being connected through the hollow
 shaft, or its equivalent, of the carrier. 40

What I claim is—

Work-support a', feed B, impression-bar
 carrier D, a tubular journal therefor, and key
 F, in combination with mechanism, substan- 45
 tially such as described, for example, balance-
 weight, rocker-arm connecting feed and
 rocker shaft, rocker-shaft, rocker-arm fast on
 rocker-shaft, lever, spindle, bracket, and lever
 for connecting key and feed, all arranged and
 operating substantially as and for the pur- 50
 pose set forth.

ANSEL G. BAKER.

Witnesses:

ROBT. SMITH,
 CHARLES S. WING.