

Feb. 17, 1953

O. C. PALMER ET AL

2,628,675

GAS BURNER AND PORT-FORMING GRID

Filed Feb. 20, 1948

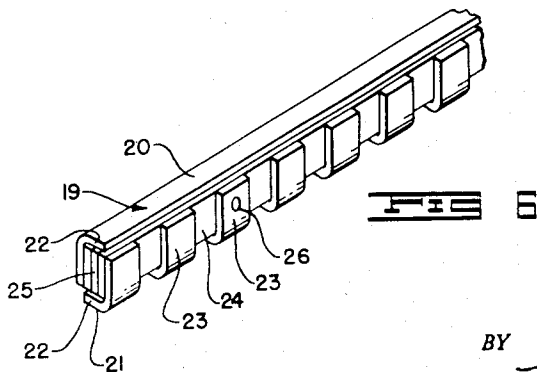
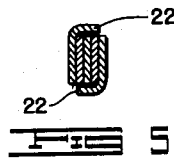
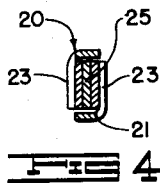
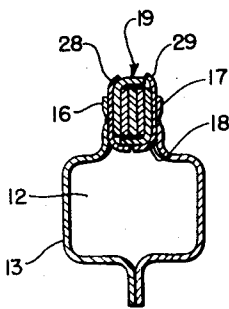
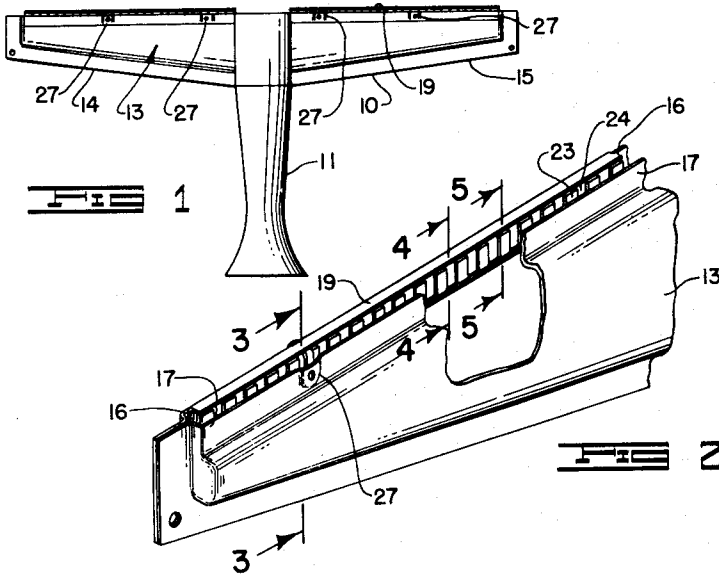

INVENTOR.
OSCAR C. PALMER
WILLIAM SCHMOLL
BY *Lyon Lyon*
ATTORNEY.

UNITED STATES PATENT OFFICE

2,628,675

GAS BURNER AND PORT-FORMING GRID

Oscar C. Palmer and William J. Schmoll, Phoenix, Ariz., assignors to Palmer Manufacturing Corp., Phoenix, Ariz., a corporation of Arizona

Application February 20, 1948, Serial No. 9,764

8 Claims. (Cl. 158-116)

1

This invention relates to space heaters and is particularly directed to an improved form of burner assembly for such devices. This invention finds particular usefulness in connection with insert grids for burner shells in providing a burner construction which promotes efficient combustion.

The principal object of this invention is to provide an improved form of burner assembly including a removable insert grid.

Another object is to provide an improved form of insert grid having an exceptionally long service life and which is made of corrosion resistant steel.

Another object is to provide a burner assembly which is economical to manufacture in quantity, yet which is accurate in construction and efficient in operation.

Another object is to provide an improved gas burner grid formed of stampings made from sheet material and adapted for assembly in a novel manner.

Another object is to provide a novel form of mounting for a burner grid within an elongated slot provided in a burner shell.

Other objects and advantages will appear hereinafter.

Referring to the drawings:

Figure 1 is a side elevation of a burner assembly embodying our invention.

Figure 2 is a perspective view partly broken away showing the manner of mounting of the insert grid within the slot provided in the burner shell.

Figure 3 is a transverse sectional view taken substantially on the lines 3-3 as shown in Figure 2.

Figure 4 is a transverse sectional view of the insert grid taken substantially on the lines 4-4 as shown in Figure 2.

Figure 5 is a view similar to Figure 4 taken substantially on the lines 5-5 as shown in Figure 2.

Figure 6 is a perspective view partly broken away showing details of the assembly of the grid insert on an enlarged scale.

Referring to the drawings, the burner assembly generally designated 10 may be provided with any conventional form of Venturi section 11 adapted to supply combustible mixture to the space 12 within the burner shell 13. The shell 13 may comprise a pair of oppositely extending projections 14 and 15 secured to the central Venturi section 11 by any convenient means. Each of the shell sections 14 and 15 may com-

2

prise metal stampings joined back to back to provide the central space 12, and provided with upwardly extending parallel walls 16 and 17 which define a channel-shaped burner opening or slot 18 therebetween. The upper edges of the walls 16 and 17 preferably terminate in the same horizontal plane. The metal stampings which form the sections 14 and 15 may be joined by any convenient means such as, for example, by spot welding or seam welding.

In accordance with our invention, a grid insert generally designated 19 is provided, and this insert is received within the slot 18 formed between the parallel walls 16 and 17. The insert 19 is preferably constructed of corrosion resistant steel of the chromium or chromium-nickel types. The insert 19 comprises a pair of identical upper and lower strips 20 and 21, each having a horizontal flange 22 and a plurality of vertically extending spacers or fingers 23 having spaces 24 therebetween. The strips 20 and 21 are preferably stamped from a sheet of material to define the length and breadth of the strip and also to provide the fingers 23 and spaces 24. The strips are then bent so that the fingers 23 may lie in a vertical plane while the flanges 22 lie in horizontal planes. A spacer block assembly 25 is then positioned between the upper and lower flanges 22 and between the fingers 23 on opposite sides of the insert 19. This spacer block assembly may comprise a single integral bar, or as shown in the drawings may comprise a plurality of strips of material cut from the same or similar sheets as the strips 20 and 21. The assembly of the strips 20 and 21 and spacer block assembly 25 is preferably accomplished by welding the parts together, and this may be readily effected by spot welding.

As shown in Figure 6, one electrode of spot welding apparatus may be placed against a finger 23 at a position 26 and the other electrode may be positioned on the corresponding finger 23 on the opposite side of the spacer block assembly 25. The simultaneous application of electrical current and pressure results in multiple spot welds connecting the various strips in the spacer block assembly 25 and also connecting the fingers 23 to the spacer block assembly. The insert grid 19, therefore, becomes an integral assembly movable as a unit into and out of position within the slot 18.

As clearly shown in Figure 2, the side faces of the fingers 23 contact the opposed faces of the walls 16 and 17 defining the slot 18, with the result that the spaces 24 between the fingers

3

23 provide accurately sized and shaped orifices for combustible gas. The flame produced when this gas is ignited is efficient in that a minimum quantity of carbon is formed and the spaces are uniform from end to end of the burner slot 18.

Means are provided for releasably holding the insert grid 19 in position, and as shown in the drawings this means includes a plurality of pockets 27 positioned at spaced intervals along the walls 16 and 17. Within each of these pockets is mounted a pair of clamping elements 28 and 29. These clamping members are joined to the walls 16 and 17 by spot welding, and their lower ends extend under the insert 19 to provide a support therefor. The upper ends extend upwardly out of the slot 18 and are deformable over portions of the insert 19 to prevent its accidental displacement upwardly from the slot.

When it is desired to clean the flame openings in the burner assembly, the upper ends of the members 28 and 29 are deflected laterally outwardly to permit the grid insert 19 to be removed as a unit. The openings 24 between adjacent fingers 23 may then be easily cleaned by means of a brush acting on a large number of openings simultaneously. Similarly, the inner faces of the walls 16 and 17 may be readily cleaned since they are substantially smooth and free from projections. The grid insert 19 may be then replaced in the slot 18 and tabs 28 and 29 deformed to prevent disassembly. The grid insert 19 acts as a single integral unit and thus facilitates cleaning and reassembly. Furthermore, the grid unit 19 is sufficiently rigid to avoid any difficulty in withdrawing or replacing it within the slot 18.

An important advantage of our improved burner assembly is that the grid unit 19 resists corrosion, and accordingly may be withdrawn repeatedly for cleaning and replaced without adversely affecting the orifices for combustible gas defined by the spaces 24 and the inner surfaces of the walls 16 and 17.

The above described burner assembly has been found to give exceptionally efficient operation on both natural gas and liquefied petroleum gas such as butane.

Having fully described our invention, it is to be understood that we do not wish to be limited to the details herein set forth, but our invention is of the full scope of the appended claims.

We claim:

1. In a gas burner assembly of the class described, the combination of: a burner shell having parallel vertical walls defining an elongated slot; a burner grid inserted into the slot, as a unit, the burner grid including a pair of substantially identical strips enclosing a spacer element, each strip having a horizontal flange and a series of horizontally spaced fingers extending therefrom, the fingers on one strip extending upwardly and the fingers on the other strip extending downwardly, the flange on the first said strip being on the bottom of the spacer element and the flange on the second said strip being on the top of the spacer element, the fingers of each series contacting an inner face on one of the parallel walls and therewith defining a series of orifices for combustible gas along each of the parallel walls.

2. A gas burner grid comprising a pair of substantially identical strips, each having a horizontal flange and a series of vertically extending horizontally spaced fingers extending therefrom, the fingers on one strip extending upward-

4

ly and the fingers on the other strip extending downwardly; a spacer element extending longitudinally of the strips and enclosed at the top and bottom between the flanges and at the sides between the two series of fingers, the spacer element cooperating with the fingers of each series to define a series of vertically extending spaces along opposite sides of the burner grid.

3. A gas burner grid comprising a pair of substantially identical strips formed of corrosion-resistant steel, each strip having a horizontal flange and a series of vertically extending horizontally spaced parallel fingers extending therefrom, the fingers on one strip extending upwardly and the fingers on the other strip extending downwardly; a spacer element extending longitudinally of the strips and enclosed at the top and bottom between the flanges and at the sides between the two series of fingers, the spacer element cooperating with the fingers of each series to define a series of vertically extending spaces along opposite sides of the burner grid.

4. A gas burner grid comprising a pair of substantially identical strips formed from sheet material, each strip having a horizontal flange and a series of vertically extending horizontally spaced fingers extending therefrom, the fingers on one strip extending upwardly and the fingers on the other strip extending downwardly; a spacer element extending longitudinally of the strips and enclosed at the top and bottom between the flanges and at the sides between the two series of fingers, the spacer element cooperating with the fingers of each series to define a series of vertically extending spaces along opposite sides of the burner grid, the strips and spacers being welded together to form an integral unit.

5. A gas burner grid comprising a pair of substantially identical strips formed of sheet material, each strip having a horizontal flange and a series of vertically extending horizontally spaced vertical fingers extending therefrom, the fingers on one strip extending upwardly and the fingers on the other strip extending downwardly; a spacer element extending longitudinally of the strips and enclosed at the top and bottom between the flanges and at the sides between the two series of fingers, the spacer element cooperating with the fingers of each series to define a series of vertically extending spaces along opposite sides of the burner grid between adjacent fingers.

6. In a gas burner assembly of the class described, the combination of: a burner shell having parallel vertical walls defining an elongated slot; a burner grid inserted into the slot as a unit, the burner grid including a pair of substantially identical strips enclosing a spacer element, each strip having a horizontal flange and a series of horizontally spaced fingers extending therefrom, the fingers on one strip extending upwardly and the fingers on the other strip extending downwardly, the flange on the first said strip being on the bottom of the spacer element and the flange on the second said strip being on the top of the spacer element, the fingers of each series contacting an inner face on one of the parallel walls and therewith defining a series of orifices for combustible gas along each of the parallel walls; pockets in the vertical walls of the shell and support means in said pockets for securing the burner grid in operative position so that a substantial portion thereof extends out of the slot.

5

7. In a gas burner assembly of the class described, the combination of: a burner shell having parallel vertical walls defining an elongated slot; a burner grid inserted into the slot as a unit, the burner grid including a pair of substantially identical strips enclosing a spacer element, each strip having a horizontal flange and a series of horizontally spaced fingers extending therefrom, the fingers on one strip extending upwardly and the fingers on the other strip extending downwardly, the flange on the first said strip being on the bottom of the spacer element and the flange on the second said strip being on the top of the spacer element, the fingers of each series contacting an inner face on one of the parallel walls and therewith defining a series of orifices for combustible gas along each of the parallel walls; and means for securing the burner grid in position within the slot, said means including pockets formed in said walls, and deformable elements in said pockets adapted to releasably secure the burner grid to the shell.

8. In a gas burner assembly of the class described, the combination of: a burner shell having parallel vertical walls defining an elongated slot; a burner grid inserted into the slot as a unit, the burner grid including a pair of substantially identical strips enclosing a spacer element, each strip having a horizontal flange and a series of horizontally spaced fingers extending therefrom, the fingers on one strip extending upwardly and the fingers on the other strip extending downwardly, the flange on the first said strip being on the bottom of the spacer element

6

and the flange on the second said strip being on the top of the spacer element, the fingers of each series contacting an inner face on one of the parallel walls and therewith defining a series of orifices for combustible gas along each of the parallel walls; and means for securing the burner grid in operative position so that a substantial portion thereof extends out of the slot, said means including pockets formed in said walls, and deformable elements in said pockets adapted to releasably secure the burner grid to the shell.

OSCAR C. PALMER.
WILLIAM J. SCHMOLL.

REFERENCES CITED

The following references are of record in the file of this patent:

UNITED STATES PATENTS

Number	Name	Date
1,405,214	Hoffman	Jan. 31, 1922
1,420,405	Beier	June 20, 1922
1,550,836	Mueller	Aug. 25, 1925
1,896,286	Burns et al.	Feb. 7, 1933
2,029,471	Field et al.	Feb. 4, 1936
2,486,278	Harper	Oct. 25, 1949
2,541,428	Leo et al.	Feb. 13, 1951

FOREIGN PATENTS

Number	Country	Date
450,535	Germany	Oct. 10, 1927
565,470	Germany	Dec. 1, 1932
501,143	Great Britain	Feb. 22, 1939