

(19) World Intellectual Property Organization  
International Bureau



(43) International Publication Date  
22 March 2001 (22.03.2001)

PCT

(10) International Publication Number  
**WO 01/19920 A1**

- (51) International Patent Classification<sup>7</sup>: C08L 53/02, A61F 13/15, B32B 27/32
- (72) Inventors: ZHANG, John, Jianbin; 11217 Acrewood Drive, Cincinnati, OH 45249 (US). CURRO, John, Joseph; 3102 Dot Drive, Cincinnati, OH 45213 (US). MANSFIELD, Michele, Ann; 580 Wirham Place, Cincinnati, OH 45220 (US).
- (21) International Application Number: PCT/US00/24924
- (22) International Filing Date: 12 September 2000 (12.09.2000)
- (74) Agents: REED, T., David et al.; The Procter & Gamble Company, 5299 Spring Grove Avenue, Cincinnati, OH 45217-1087 (US).
- (25) Filing Language: English
- (26) Publication Language: English
- (81) Designated States (national): AE, AG, AL, AM, AT, AT (utility model), AU, AZ, BA, BB, BG, BR, BY, BZ, CA, CH, CN, CR, CU, CZ, CZ (utility model), DE, DE (utility model), DK, DK (utility model), DM, DZ, EE, EE (utility model), ES, FI, FI (utility model), GB, GD, GE, GH, GM, HR, HU, ID, IL, IN, IS, JP, KE, KG, KP, KR, KR (utility model), KZ, LC, LK, LR, LS, LT, LU, LV, MA, MD, MG, MK, MN, MW, MX, MZ, NO, NZ, PL, PT, RO, RU, SD,
- (30) Priority Data: 09/398,849 17 September 1999 (17.09.1999) US
- (71) Applicant: THE PROCTER & GAMBLE COMPANY [US/US]; One Procter & Gamble Plaza, Cincinnati, OH 45202 (US).

[Continued on next page]

(54) Title: LOW STRESS RELAXATION ELASTOMERIC MATERIALS

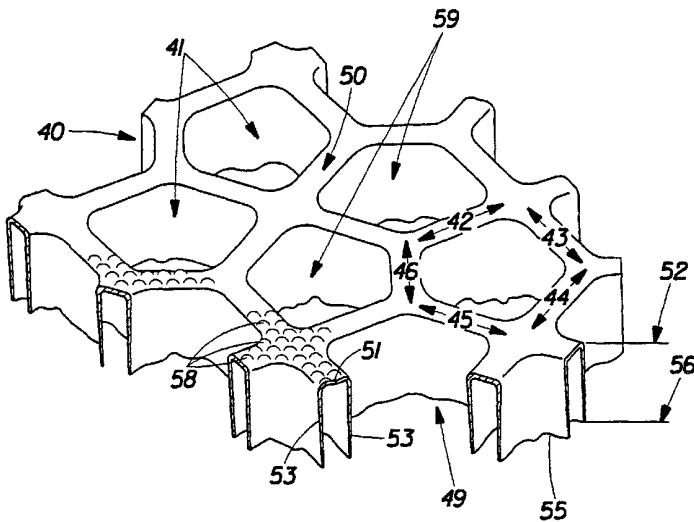

(57) Abstract: A low stress relaxation elastomeric material comprises a block copolymer having an elastomeric soft block portion and thermoplastic hard block portions, at least one vinylarene resin and mineral oil. The elastomeric material may be used in a film comprising an elastomeric layer and at least one substantially less elastomeric skin layer. The skin layer comprises a thermoplastic polymer such as polyolefins. The film exhibits desired elastic and stress relaxation properties at body temperature. The film is useful in forming a macroscopically-expanded, three-dimensional elastomeric web.

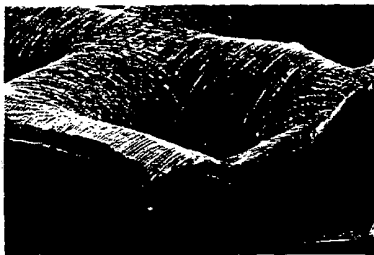

WO 01/19920 A1



SE, SG, SI, SK, SK (utility model), SL, TJ, TM, TR, TT, TZ, UA, UG, UZ, VN, YU, ZA, ZW.

**(84) Designated States (regional):** ARIPO patent (GH, GM, KE, LS, MW, MZ, SD, SL, SZ, TZ, UG, ZW), Eurasian patent (AM, AZ, BY, KG, KZ, MD, RU, TJ, TM), European patent (AT, BE, CH, CY, DE, DK, ES, FI, FR, GB, GR, IE, IT, LU, MC, NL, PT, SE), OAPI patent (BF, BJ, CF, CG, CI, CM, GA, GN, GW, ML, MR, NE, SN, TD, TG).

**Published:**

- *With international search report.*
- *Before the expiration of the time limit for amending the claims and to be republished in the event of receipt of amendments.*

*For two-letter codes and other abbreviations, refer to the "Guidance Notes on Codes and Abbreviations" appearing at the beginning of each regular issue of the PCT Gazette.*

## LOW STRESS RELAXATION ELASTOMERIC MATERIALS

### FIELD OF THE INVENTION

The present invention relates to low stress relaxation elastomeric materials suitable for use in macroscopically-expanded, three-dimensional, apertured polymeric webs.

5

### BACKGROUND OF THE INVENTION

It has long been known in the field of disposable absorbent articles that it is desirable to construct absorptive devices, such as disposable diapers with fasteners, pull-on diapers, training pants, sanitary napkins, pantliners, incontinent briefs, and the like, with elastic elements to improve the range of size, ease of motion, and sustained fit. It is also well known that it is preferable, especially in such products intended to be worn in hot and humid conditions, to provide adequate porosity to all areas of the article where undue occlusion of the skin may cause sensitized skin or heat rash. Due to the nature of many disposable absorbent articles there is a high potential for skin irritation due to trapping of moisture and other body exudates between the elasticized portion of the article and the skin of the wearer. Elasticized portions of disposable articles are particularly prone to causing skin irritations as they tend to be more conformable to the body, and therefore more likely to occlude areas of the skin, often for long periods of time. Various methods are known in the art for imparting elasticity to polymer films. As materials with greater elasticity provide health care or personal hygiene products with a better fit to the body, the air flow to the skin and the vapor flow from the occluded areas are reduced. Breathability (particularly vapor permeability) becomes more important for skin health. Various methods are also known in the art for imparting porosity to polymer films to improve breathability, but there remains a need for a polymeric film or web that provides for both adequate elasticity and porosity, such as may be adapted for durable, prolonged use in personal hygiene or health care products, particularly disposable articles, bandages, wraps, and wound dressings.

25

Disposable diapers and other absorbent articles fitted with elasticized leg cuffs or elasticized waist bands for a more comfortable fit, as well as providing for better leakage control, are known in the art. Often, the elasticity is accomplished with a heat treatment of polymeric materials that results in a desirable shirring or gathering of a portion of the diaper. One such method of treatment is disclosed in U.S. Pat. No. 4,681,580, issued to Reising et al. on July 21, 1987, and hereby incorporated by reference herein. Other methods for imparting elasticity are taught in U.S. Pat. No. 5,143,679 issued to Weber et al. on Sept. 1, 1992, U.S. Pat. Nos. 5,156,793 issued to

30

Buell et al. on Oct. 20, 1992 and 5,167,897 issued to Weber et al. on Dec. 1, 1992, all are hereby incorporated by reference herein.

Several means of rendering elasticized planar polymer films more porous are known in the art, such as die punching, slitting, and hot-pin melt aperturing. However, when any of the above techniques is applied to thermoplastic elastomeric films, the increase in porosity is accompanied by a decrease in the degree of reliable elastic performance. For example, in the case of circular apertures in a planar film, it is well known that for an applied stress  $S_1$ , a resultant local stress,  $S_2$ , is created orthogonal to the applied stress about the apertures. This local stress,  $S_2$ , is greater than  $S_1$ , approaching a magnitude up to 3 times the applied stress. For non-round apertures the concentration of stress can be even greater. As a result, apertures become sources of tear initiation sites at their edges, because the edges of the material form the edges of the apertures in the plane of applied stress. For common thermoplastic elastic films, such apertures facilitate tear initiation which can propagate over time leading to catastrophic failure of the film. When used in elasticized portions of disposable absorbent articles, this failure results in the loss of important elastic characteristics, including loss of comfort, fit and use of the absorbent article.

Prior art web structures that do provide adequate porosity so as to be preferable for use as the wearer-contacting surface on disposable absorbent articles have been of two basic varieties, i.e., inherently fluid-pervious structures, such as fibrous nonwovens, and fluid-impervious materials such as polymeric webs which have been provided with a degree of fluid permeability via aperturing to permit fluid and moisture flow therethrough. Neither variety is characteristically elastic, and as a result both are generally used in regions of an absorbent article requiring fluid permeability but not extensibility, such as the body-contacting layer of a catamenial pad.

Commonly assigned U.S. Pat. No. 3,929,135 issued to Thompson on Dec. 30, 1975, and hereby incorporated herein by reference, suggests a suitable body-contacting porous polymeric web for disposable articles. Thompson teaches a macroscopically-expanded, three-dimensional topsheet comprised of liquid-impermeable polymeric material. However, the polymeric material is formed to comprise tapered capillaries, the capillaries having a base opening in the plane of the topsheet, and an apex opening in intimate contact with the absorbent pad utilized in the disposable absorbent article. The polymer material taught by Thompson is not generally an elastomer, however, and Thompson depends on the inelastic properties of the heat-molded single layer film to produce the desired three-dimensional structure.

Still another material which has been utilized as a body contacting surface in a disposable absorbent article context is disclosed in commonly assigned U.S. Pat. No. 4,342,314 issued to Radel et al. on Aug. 3, 1982, and hereby incorporated herein by reference. The Radel et al. patent

discloses an improved macroscopically-expanded three-dimensional plastic web comprising a regulated continuum of capillary networks originating in and extending from one surface of the web and terminating in the form of apertures in the opposite surface thereof. In a preferred embodiment, the capillary networks are of decreasing size in the direction of liquid transport.

5           The macroscopically-expanded three-dimensional plastic webs of the type generally described in the aforementioned commonly assigned Thompson and Radel et al. patents have met with good success in permitting adequate vapor permeability due to the porosity provided by the apertures. However, because of material limitations such webs do not generally possess the requisite elasticity to allow the resulting web to have significant elastomeric characteristics. This  
10 shortcoming substantially limits the use of such webs in elasticized portions of an absorbent article.

Elasticized polymeric webs may be produced from elastomeric materials known in the art, and may be laminates of polymeric materials such as disclosed in U.S. Pat. No. 5,501,679, issued to Krueger et al. on March 26, 1996. Laminates of this type are generally prepared by coextrusion  
15 of elastomeric materials and inelastic skin layers followed by stretching the laminate past the elastic limit of the skin layers and then allowing the laminate to recover. Elastomeric webs or films such as those described above may be used in the body hugging portions of garments, such as the waistbands, leg cuffs and side panels, but are generally not porous enough to prevent undesirable skin irritations when used for prolonged periods of time.

20           Additionally, the actual use condition for absorbent articles or other personal care products typically involves heat, humidity, loading or combinations thereof. Some elastomeric materials suffer loss of elastic properties and dimensional stability at body temperature, especially under load or tension. The loss of elastic properties and dimensional stability results in sagging and ill-fitting of the absorbent article, and in severe cases, leakage from the absorbent article may result.

25           The elastic components of certain articles, such as training pants, pull-on diapers, disposable diapers with fasteners, adult incontinence garments, bandages, wraps, wound dressings, and the like, may be subjected to considerable amount of stretching, at a strain as large as 400% of its original dimension, while the article is being put on the body of the wearer. This step imposes additional requirements of stretchability and recoverability on the elastomeric material

30           There is considerable difficulty in processing and handling elastomeric materials, due to the inherent tacky and stretchy nature of the elastomeric materials. The elastomeric materials have a tendency to stick to the processing equipment, and are difficult to remove from a roll or cut to the correct size to be incorporated into the finished products.

Therefore, it is desirable to provide an elastomeric material which substantially retain its elastic properties under actual use condition of the finished product over a specified period of time, for example, at body temperature under sustained load for about 10 hours.

It is desirable to provide such an elastomeric film that is form-fitting and breathable (i.e., vapor permeable).

More particularly, in a particularly preferred embodiment, it would be desirable to provide a macroscopically-expanded three-dimensional apertured elastomeric web that is able to substantially recover its three-dimensional shape after being subjected to an applied strain of up to about 400% or more.

It is further desirable to provide an elastomeric film suitable for use in an apertured elastomeric web designed to dissociate the effects of an applied strain on the web from the edges of the apertures and hence retard or prevent the onset of tear initiation.

Furthermore, it is desirable to provide such an elastomeric material that has improved processability and is cost-effective for personal hygiene products and health care products, such as pull-on diapers, training pants, disposable diapers with fasteners, incontinence garments, sanitary napkins, pantliners, wound dressings, bandages, and wraps.

### SUMMARY OF THE INVENTION

The present invention pertains to a low stress relaxation elastomeric material. The elastomeric material can be used alone or with skin layers to form an elastomeric film. The elastomeric film is useful in a forming process to provide a porous, macroscopically-expanded, three-dimensional, elastomeric web. In a preferred embodiment, the elastomeric web is suitable for use in elasticized or body-hugging portions of disposable absorbent articles such as side panels, waist bands, cuffs, or of health care products such as dressings, bandages and wraps. The porous extensible polymeric webs of the present invention may also be used in other portions of the absorbent articles where a stretchable or breathable material is desired, such as topsheets or backsheets.

The elastomeric materials of the present invention preferably exhibit low stress relaxation at body temperature and under load or stress for a specified period of time. The elastomeric materials also exhibit low hysteresis and high elongation at break when subjected to a large deformation. In a preferred embodiment, the elastomeric material comprises a styrenic block copolymer such as polystyrene-poly(ethylene/propylene)-polystyrene (S-EP-S), polystyrene-poly(ethylene/butylene)-polystyrene (S-EB-S), polystyrene-polybutylene-polystyrene (S-B-S), polystyrene-polyisoprene-polystyrene (S-I-S), or hydrogenated polystyrene-

poly(isoprene/butadiene)-polystyrene (S-IB-S) at least one vinylarene resin, and a processing oil, particularly a low viscosity hydrocarbon oil such as mineral oil.

The elastomeric materials of the present invention may be in a monolithic film or in a multilayer film with at least one substantially less elastomeric skin layer such as polyolefin type materials, including polyethylene and polypropylene. The elastomeric films are useful in forming macroscopically-expanded, three dimensional, elastomeric webs.

In a preferred embodiment, the web has a continuous first surface and a discontinuous second surface remote from the first surface. The elastomeric web exhibits a multiplicity of primary apertures in the first surface of the web, the primary apertures being defined in the plane of the first surface by a continuous network of interconnecting members, each interconnecting member exhibiting an upwardly concave-shaped cross-section along its length. In a preferred embodiment each interconnecting member exhibits a generally U-shaped cross-section along a portion of its length, the cross-section comprising a base portion generally in the plane of the first surface of the web and sidewall portions joined to each edge of the base portion and interconnected with other sidewall portions. The interconnected sidewall portions extend generally in the direction of the second surface of the web, and are interconnected to one another intermediate the first and the second surfaces of the web. The interconnected sidewall portions terminate substantially concurrently with one another to form a secondary aperture in the plane of the second surface of the web.

When used as an extensible, porous member in an absorbent article, the elastomeric layer of the present invention allows the interconnecting members to stretch in the plane of the first surface. The three-dimensional nature of the web allows the strain on the interconnecting members in the plane of the first surface to be dissociated from the strain at the secondary apertures in the secondary surface, and therefore decoupled from potential strain-induced stress at tear initiation sites. This dissociation, or decoupling, of the strain-induced stress of the web from strain-induced stress at the secondary apertures significantly increases web reliability by allowing repeated and sustained web strains of up to about 400% or more without failure of the web due to tear initiation at the apertures.

Also disclosed is a method of producing the elastomeric web of the present invention which comprises providing a multilayer elastomeric film, supporting the film on a forming structure, and applying a fluid pressure differential across the thickness of the multilayer film. The fluid pressure differential is sufficiently great to cause the multilayer film to conform to the supporting structure and rupture in at least portions of the formed film.

While the specification concludes with claims particularly pointing out and distinctly claiming the subject matter of the present invention, it is believed that the present invention will be better understood from the following description taken in conjunction with the accompanying drawings in which like reference numerals identify identical elements and wherein:

5 FIG. 1 is an enlarged, partially segmented, perspective illustration of a prior art polymeric web of a type generally disclosed in commonly assigned U.S. Pat. No. 4,342,314;

FIG. 2 is an enlarged, partially segmented, perspective illustration of a preferred elastomeric web of the present invention having two layers of polymer film, at least one of which is elastomeric;

10 FIG. 3 is a further enlarged, partial view of a web of the type generally shown in FIG. 2, but illustrating in greater detail the web construction of an alternative elastomeric web of the present invention;

FIG. 4 is an enlarged cross-sectional view of a preferred multilayer film of an elastomeric web of the present invention having an elastomeric layer interposed between two skin layers;

15 FIG. 5 is a plan view of aperture shapes projected in the plane of the first surface of an alternative elastomeric web of the present invention;

FIG. 6 is an enlarged cross-sectional view of an interconnecting member taken along section line 6-6 of FIG. 5;

20 FIG. 7 is another enlarged cross-sectional view of an interconnecting member taken along section line 7-7 of FIG. 5;

FIGs. 8A-8C are schematic representations of a cross-section of an aperture of an elastomeric web of the present invention in various states of tension;

FIG. 9 is an enlarged optical photomicrograph showing the first surface of an elastomeric web of the present invention having an ordered pattern of approximately 1 mm square apertures;

25 FIG. 10 is an enlarged scanning electron microscope photomicrograph perspective illustration of the second surface of the elastomeric web shown in FIG. 9 in an unstretched state;

FIG. 11 is an enlarged scanning electron microscope photomicrograph perspective illustration of the second surface of the elastomeric web shown in FIG. 9 tensioned to approximately 100% elongation;

30 FIG. 12 is an enlarged scanning electron microscope photomicrograph perspective illustration of an aperture of an elastomeric web of the present invention showing rugosities formed after extension and recovery;

FIG. 13 is a partially segmented perspective illustration of a disposable garment comprising the elastomeric web of the present invention;



FIG. 14 is a simplified, partially segmented illustration of a preferred embodiment of side panels for a disposable garment;

FIG. 15 is a simplified, partially exploded perspective illustration of a laminate structure generally useful for forming the web structure illustrated in FIG. 2;

5 FIG. 16 is a perspective view of a tubular member formed by rolling a planar laminate structure of the type generally illustrated in FIG. 15 to the desired radius of curvature and joining the free ends thereof to one another;

FIG. 17 is a simplified schematic illustration of a preferred method and apparatus for debossing and perforating an elastomeric film generally in accordance with the present invention;

10 FIG. 18 is an enlarged, partially segmented perspective illustration of an alternative elastomeric web of the present invention; and

FIG. 19 is an enlarged cross sectional illustration of the web of FIG. 18 taken along section line 19-19.

#### 15 DETAILED DESCRIPTION OF THE PRESENT INVENTION

As used herein, the term “comprising” means that the various components, ingredient, or steps can be conjointly employed in practicing the present invention. Accordingly, the term “comprising” encompasses the more restrictive terms “consisting of” and “consisting essentially of”.

20 As used herein, the terms “elastic” or “elastomeric” refer to any material which is capable of being elongated or deformed under an externally applied force, and which will substantially resume its original dimension or shape, sustaining only small permanent set (typically no more than about 20%), after the external force is released. The term “elastomer” refers to any material exhibiting elastic properties as described hereinabove.

25 As used herein, the term “thermoplastic” refers to any material which can be melted and resolidified with little or no change in physical properties (assuming a minimum of oxidative degradation).

As used herein the term “skin layer” refers to a layer comprising a thermoplastic polymer or polymeric blend that is substantially less elastomeric than the elastomeric layer. The skin layer is considered “substantially less elastomeric” if the permanent set of the skin layer is at least about 30 20% greater than that of the elastomeric layer. Permanent set refers to the deformation of a material measured in a sufficient time after the material is released from a specified elongation to allow the material to snap back fully.

As used herein, the term "percent elongation" refers to the difference between the length of an elastomeric material measured while the material is elongated under an applied force and the length of the material in its undeformed or unstrained state, dividing by the length of the material in its undeformed state, then multiplying by 100. For example, a material in its undeformed or unstrained state has a 0% elongation.

As used herein, the terms "set" or "percent set" refer to the percent deformation of an elastomeric material measured while the material is in a relaxed condition for a specified period of time (i.e., 60 seconds for the Test Methods described herein) after the material was released from a specified elongation without allowing the material to snap back completely. The percent set is expressed as  $[(\text{zero load extension after one cycle} - \text{initial sample gauge length of cycle 1}) / (\text{initial sample gauge length of cycle 1})] \times 100$ . Zero load extension refers to the distance between the jaws at the beginning of the second cycle before a load is registered by the tensile testing equipment.

As used herein, the term "stress relaxation" refers to the percentage loss of tension or load between the maximum load or force encountered after elongating an elastomeric material at a specific rate of extension to a predetermined length (or the load or force measured at some initial length) and the remaining load or force measured after the sample has been held at that length or elongation for a specified period of time. Relaxation is expressed as percentage loss of the initial load encountered at a specific extension of an elastomeric material.

As used herein, the term "hysteresis" refers to the difference between the energy retained by an elastomeric material during retraction from a specified elongation and the energy required to subsequently elongate the elastomeric material to that previous length. Stretching an elastomeric material to a specified elongation, typically 200% elongation, and returning to zero load completes a hysteresis loop.

Other terms are defined herein where initially discussed.

FIG. 1 is an enlarged, partially segmented, perspective illustration of a prior art macroscopically-expanded, three-dimensional, fiber-like, fluid pervious polymeric web **40** which has been found highly suitable for use as a topsheet in disposable absorbent articles, such as diapers and sanitary napkins. The prior art web is generally in accordance with the teachings of commonly assigned U.S. Pat. No. 4,342,314 issued to Radel et al. on Aug. 3, 1982, which is hereby incorporated herein by reference. The fluid pervious web **40** exhibits a multiplicity of apertures, e.g., apertures **41**, which are formed by a multiplicity of interconnected fiber-like elements, e.g., fiber-like elements **42**, **43**, **44**, **45**, and **46** interconnected to one another in the first

surface 50 of the web. Each fiber-like element comprises a base portion, e.g., base portion 51, located in plane 52 of the first surface 50. Each base portion has a sidewall portion, e.g., sidewall portion 53, attached to each edge thereof. The sidewall portions extend generally in the direction of the second surface 55 of the web. The intersecting sidewall portions of the fiber-like elements are interconnected to one another intermediate the first and second surfaces of the web, and terminate substantially concurrently with one another in the plane 56 of the second surface 55.

In a preferred embodiment, the base portion 51 includes a microscopic pattern of surface aberrations 58 generally in accordance with the teachings of U.S. Pat. No. 4,463,045, issued to Ahr et al. on July 31, 1984, the disclosure of which is hereby incorporated herein by reference. The microscopic pattern of surface aberrations 58 provides a substantially non-glossy visible surface when the web is struck by incident light rays.

In an alternative embodiment the prior web may include a multiplicity of much smaller capillary networks (not shown) in the first surface 50 of the web, as taught by U.S. Pat. No. 4,637,819 to Ouellette et al. issued Jan. 20, 1987 and hereby incorporated herein by reference. It is believed that the additional porosity afforded by the smaller fluid-handling capillary networks may allow the web of the present invention function more efficiently when used as an extensible, porous portion of a disposable absorbent article.

As utilized herein, the term "interconnecting members" refers to some or all of the elements of the elastomeric web, portions of which serve to define the primary apertures by a continuous network. Representative interconnecting members include, but are not limited to, the fiber-like elements of the aforementioned '314 Radel et al. patent and commonly assigned U.S. Patent No. 5,514,105 to Goodman, Jr., et al. issued on May 7, 1996 and hereby incorporated herein by reference. As can be appreciated from the following description and drawings, the interconnecting elements are inherently continuous, with contiguous interconnecting elements blending into one another in mutually-adjoining transition portions.

Individual interconnecting members can best be generally described, with reference to FIG. 1, as those portions of the elastomeric web disposed between any two adjacent primary apertures, originating in the first surface 50 and extending to the second surface 55. On the first surface of the web the interconnecting members collectively form a continuous network, or pattern, the continuous network of interconnecting members defining the primary apertures, and on the second surface of the web the interconnecting sidewalls of the interconnecting members collectively form a discontinuous pattern of secondary apertures.

As utilized herein, the term "continuous", when used to describe the first surface of the elastomeric web, refers to the uninterrupted character of the first surface, generally in the plane of

the first surface. Thus, any point on the first surface can be reached from any and every other point on the first surface without substantially leaving the first surface in the plane of the first surface. Likewise, as utilized herein, the term "discontinuous," when used to describe the second surface of the elastomeric web, refers to the interrupted character of the second surface, generally in the plane of the second surface. Thus, any point on the second surface cannot be reached from every other point on the second surface without substantially leaving the second surface in the plane of the second surface.

In general, as utilized herein the term "macroscopic" is used to refer to structural features or elements which are readily visible to a normal human eye when the perpendicular distance between the viewer's eye and the plane of the web is about 12 inches. Conversely, the term "microscopic" is utilized to refer to structural features or elements which are not readily visible to a normal human eye when the perpendicular distance between the viewer's eye and the plane of the web is about 12 inches.

As utilized herein, the term "macroscopically-expanded", when used to describe three-dimensional elastomeric webs, ribbons and films, refers to elastomeric webs, ribbons and films which have been caused to conform to the surface of a three-dimensional forming structure so that both surfaces thereof exhibit the three-dimensional pattern of the forming structure. Such macroscopically-expanded webs, ribbons and films are typically caused to conform to the surface of the forming structures by embossing (i.e., when the forming structure exhibits a pattern comprised primarily of male projections), by debossing (i.e., when the forming structure exhibits a pattern comprised primarily of female capillary networks), or by extrusion of a resinous melt onto the surface of a forming structure of either type.

By way of contrast, the term "planar" when utilized herein to describe plastic webs, ribbons and films, refers to the overall general condition of the web, ribbon or film when viewed by the naked eye on a macroscopic scale. For example, a non-apertured extruded film or an apertured extruded film that does not exhibit significant macroscopic deformation out of the plane of the film would generally be described as planar. Thus, for an apertured, planar web the edge of the material at the apertures is substantially in the plane of the web, causing applied web stresses in the plane of the web to be coupled directly to tear initiation sites at the apertures.

When macroscopically-expanded, the multilayer film of the elastomeric web of the present invention is formed into three-dimensional interconnecting members which may be described as channel-like. Their two-dimensional cross-section may also be described as "U-shaped", as in the aforementioned Radel et al. patent, or more generally as "upwardly concave-shaped", as disclosed in the aforementioned Goodman, Jr., et al. patent. "Upwardly concave-shaped" as used herein describes the orientation of the channel-like shape with relation to the surfaces of the elastomeric

web, with the base generally in the first surface, and the legs of the channel extending from the base in the direction of the second surface, and with the channel opening being substantially in the second surface. In general, as described below with reference to FIG. 5, for a plane extending through the web orthogonal to the plane of the first surface and intersecting any two adjacent primary apertures, the resulting cross-section of an interconnecting member disposed between will exhibit a generally upwardly concave shape that may be substantially U-shaped.

Several means of rendering non-apertured planar elasticized polymeric webs more porous are known in the art, such as die punching, slitting, and hot-pin melt aperturing. However, when any of the above techniques is applied to thermoplastic elastomeric films, the increase in porosity is typically accompanied by a decrease in the degree of reliable elastic performance. Once perforated by conventional methods the edges of the apertures become sources of tear initiation sites as forces are applied to the web since they lie in the plane of applied stress. For common thermoplastic elastic films, web stress will initiate tears at the apertures which propagate over time leading to catastrophic failure of the film. If the aperture shapes are non-round, e.g., square, triangular, or other polygons, potential for tear initiation increases due to the stress concentrations at the angular intersection of sides.

Applicant has found in the present invention that by utilizing a multilayer polymeric web comprising an elastomeric layer in combination with at least one skin layer, and forming the multilayer web into a macroscopically-expanded, three-dimensional configuration according to the method described herein, the resulting elastomeric web exhibits the advantages of high porosity and high elasticity, as well as reliability, and high strength.

Preferably, the elastomeric layer itself is capable of undergoing from 50% to 1200% elongation at room temperature when in a non-apertured, planar condition. The elastomer can be either pure elastomers or a blend with an elastomeric phase or content that will still exhibit substantial elastomeric properties at ambient temperatures, including human body temperatures. The elastomeric materials of the present invention, may exhibit desired elastic and stress relaxation properties, in a monolithic film, in a multilayer film with at least one elastomeric layer, or in a porous, three-dimensional web made according to the method described herein. Preferably the elastomeric materials of the exhibit a stress relaxation at 200% elongation of less than about 20%, more preferably less than about 30%, and most preferably less than about 40% at room temperature. The elastomeric materials of the present invention exhibits a stress of less than about 45%, preferably less than about 50%, and more preferably less than about 55% relaxation, at 50% elongation after 10 hours at body temperature (about 100°F).

The skin layer of the present invention is preferably thinner and substantially less elastic than the elastomeric layer, and may in the limiting case be generally inelastic. There may be more than one skin layer used in conjunction with the elastomeric layer of the present invention, and it, or they, will generally modify the elastic properties of the elastomer. If more than one skin layer is used, the skin layers may have the same or different material characteristics.

FIG. 2 is an enlarged partially segmented, perspective illustration of a macroscopically-expanded, three-dimensional, elastomeric web embodiment of the present invention, generally indicated as **80**. The geometrical configuration of the fluid-pervious, elastomeric web **80** is generally similar to that of prior art web **40**, illustrated in FIG. 1, and is generally in accordance with the teachings of the aforementioned '314 Radel et al. patent. Other suitable formed film configurations are described in U.S. Pat. No. 3,929,135, issued to Thompson on Dec. 30, 1975; U.S. Pat. No. 4,324,246 issued to Mullane, et al. on April 13, 1982; and U.S. Pat. No. 5,006,394 issued to Baird on April 9, 1991. The disclosures of each of these patents are hereby incorporated herein by reference.

A preferred embodiment of an elastomeric web **80** of the present invention exhibits a multiplicity of primary apertures, e.g., primary apertures **71**, which are formed in plane **102** of the first surface **90** by a continuous network of interconnecting members, e.g., members **91**, **92**, **93**, **94**, **95** interconnected to one another. The shape of primary apertures **71** as projected on the plane of the first surface **90** are preferably in the shape of polygons, e.g., squares, hexagons, etc., in an ordered or random pattern. In a preferred embodiment each interconnecting member comprises a base portion, e.g., base portion **81**, located in plane **102**, and each base portion has a sidewall portion, e.g., sidewall portions **83**, attached to each edge thereof. The sidewall portions **83** extend generally in the direction of the second surface **85** of the web and intersect with side walls of adjoining interconnecting members. The intersecting sidewall portions are interconnected to one another intermediate the first and second surfaces of the web, and terminate substantially concurrently with one another to form a secondary aperture, e.g., secondary apertures **72** in the plane **106** of the second surface **85**. Detailed description of the porous macroscopically-expanded, three-dimensional elastomeric web is disclosed in U.S. Patent Application Serial No. 08/816,106, filed on March 14, 1997 by Curro et al., the disclosure of which is incorporated herein by reference.

FIG. 3 is a further enlarged, partial view of a web of the type generally similar to web **80** of FIG. 2, but illustrating an alternative web construction according to the present invention. The multilayer polymeric formed film **120** of web **80** is preferably comprised of at least one elastomeric layer **101**, and at least one skin layer **103**. While FIG. 3 shows a two-layer

embodiment with the skin layer 103 nearer the first surface 90, it is believed that the order of layering of the formed film 120 is not limiting. While it is presently preferred that as shown in FIG. 3 the polymeric layers terminate substantially concurrently in the plane of the second surface, it is not presently believed to be essential that they do so, i.e., one or more layers may extend further toward the second surface than the others. The elastomeric layer comprises from about 20% to about 95% of the total thickness of the film and each skin layer comprises from about 1% to about 40% of the total thickness of the film. Typically, the elastomeric film has a thickness of from about 0.5 mils to about 20 mils, preferably from about 1.0 mil to 5.0 mils. Each skin layer is typically about 0.05 mil to about 5 mils thick, and preferably from about 0.1 mil to about 1.5 mils thick. In a preferred embodiment, the elastomeric layer is about 3.2 mils thick and each skin layer is about 0.15 mil thick.

A particularly preferred multilayer polymeric film 120 of the web 80 is depicted in cross-section in FIG. 4, showing an elastomeric layer 101 interposed between two skin layers 103. The elastomeric layer 101 preferably comprises a thermoplastic elastomer having at least one elastomeric portion and at least one thermoplastic portion. The thermoplastic elastomer typically comprises a substantially continuous amorphous matrix, with glassy or crystalline domains interspersed throughout. Not intending to be bound by theory, it is believed that the discontinuous domains act as effective physical crosslinks which enable the material to exhibit an elastic memory when the material is subjected to an applied strain and subsequently released. Preferred thermoplastic elastomeric materials include block copolymers and blends thereof. The thermoplastic elastomeric materials suitable for use in the present invention include styrene-butadiene-styrene or like styrenic block copolymers. Also suitable for use herein as the thermoplastic elastomeric materials are certain polyolefins which exhibit the desired thermoplastic elastomeric character and resultant elastic properties, for example, polyethylenes and polypropylenes having densities below about 0.90 g/cc. The skin layers preferably comprise substantially less elastomeric materials such as polyolefins having densities greater than about 0.90 g/cc or other thermoplastic materials. The skin layers should have sufficient adhesion to the elastomeric layer such that it will not completely delaminate either before or after stretching of the web. The materials suitable for use herein as the skin layer should have the desired melt flow properties such that it can be successfully processed with the elastomeric layer to form a multilayer film. A preferred method to produce the multilayer polymeric film 120 is coextrusion.

In general, an elastomeric, low stress relaxation material with desired elastic and stress relaxation properties may be prepared from a composition which comprises an elastomeric block copolymer, at least one thermoplastic resin or blend and a low viscosity processing oil. A

preferred composition comprises about 55 wt% of a styrenic-olefinic triblock copolymer, about 15 wt% of polystyrene, and about 30 wt% of mineral oil. The compositions may further include other additives such as antioxidants, anti-block agents and anti-slip agents. Typically the antioxidants are no more than 1%, preferably no more than 0.5% of the total weight of the elastomeric compositions.

A number of block copolymers can be used to prepare the elastomeric compositions useful in preparing the low stress relaxation elastomeric film or sheet of the present invention. Linear block copolymers, such as A-B-A triblock copolymers, A-B-A-B tetrablock copolymers, A-B-A-B-A pentablock copolymers, or the like, are suitably selected on the basis of block content and average molecular weights of the blocks. Such block copolymers generally comprise an elastomeric block portion B and a thermoplastic block portion A. The block copolymers suitable for use herein are thermoplastic and elastomeric. The block copolymers are elastomeric in the sense that they generally form a three-dimensional physical crosslinked or entangled structure below the glass transition temperature ( $T_g$ ) of the thermoplastic block portion such that they exhibit elastic memories in response to external forces. The block copolymers are thermoplastic in the sense that they can be melted above the endblock  $T_g$ , formed, and resolidified several times with little or no change in physical properties (assuming a minimum of oxidative degradation).

In such copolymers, the block portion A are the hard blocks and are derived from materials which have a sufficiently high glass transition temperature to form crystalline or glassy domains at the use temperature of the polymer. Such hard blocks generally form strong physical entanglements or agglomerates with other hard blocks in the copolymers. The hard block portion A generally comprises a polyvinylarene derived from monomers such as styrene,  $\alpha$ -methyl styrene, other styrene derivatives, or mixtures thereof. The hard block portion A may also be a copolymer derived from styrenic monomers such as those described hereinabove and olefinic monomers such as ethylenes, propylenes, butylenes, isoprenes, butadienes, and mixtures thereof.

The hard block portion A preferably is polystyrene, having a number-average molecular weight between from about 1,000 to about 200,000, preferably from about 2,000 to about 100,000, more preferably from about 5,000 to about 60,000. Typically the hard block portion A comprises from about 10% to about 80%, preferably from about 20% to about 50%, more preferably from about 25 to about 35% of the total weight of the copolymer.

The material forming the B-block will have sufficiently low glass transition temperature at the use temperature of the polymer such that crystalline or glassy domains are not formed at these working temperatures. The B-block may thus be regarded as a soft block. The soft block portion B is typically an olefinic polymer derived from conjugated aliphatic diene monomers of



from about 4 to about 6 carbon atoms or linear alkene monomers of from about 2 to about 6 carbon atoms. Suitable diene monomers include butadiene, isoprene, and the like. Suitable alkene monomers include ethylene, propylene, butylene, and the like. The soft block portion B preferably comprises a substantially amorphous polyolefin such as ethylene/propylene polymers, ethylene/butylene polymers, polyisoprene, polybutadiene, and the like or mixtures thereof. The number-average molecular weight of the soft block B is typically from about 1,000 to about 300,000, preferably from about 10,000 to about 200,000, and more preferably from about 20,000 to about 100,000. Typically the soft block portion B comprises from about 20% to about 90%, preferably from about 50% to about 80%, more preferably from about 65% to about 75% of the total weight of the copolymer.

Suitable block copolymers for use in this invention comprise at least one substantially elastomeric block portion B and at least one substantially thermoplastic block portions A. The block copolymers may have multiple blocks. In a preferred embodiment, the block copolymer may be an A-B-A triblock copolymer, an A-B-A-B tetrablock copolymer, or an A-B-A-B-A pentablock copolymer. Also preferred for use herein are triblock copolymers having an elastomeric midblock B and thermoplastic endblocks A and A', wherein A and A' may be derived from different vinylarene monomers. Also useful in the present invention are block copolymers having more than one A block and/or more than one B block, wherein each A block may be derived from the same or different vinylarene monomers and each B block may be derived from the same or different olefinic monomers. The block copolymers may also be radial, having three or more arms, each arm being an B-A, B-A-B-A, or the like type copolymer and the B blocks being at or near the center portion of the radial polymer. Good results may be obtained with, for example, four, five, or six arms. The olefin block typically comprises at least about 50 percent by weight of the block copolymer. The unsaturation in olefinic double bonds may be selectively hydrogenated, if desired, to reduce sensitivity to oxidative degradation and may have beneficial effects on the elastomeric properties. For example, a polyisoprene block can be selectively reduced to form an ethylene-propylene block. The vinylarene block typically comprises at least about 10 percent by weight of the block copolymer. However, higher vinylarene content is more preferred for high elastic and low stress relaxation properties.

The block copolymer may be used in the elastomeric composition in an amount effective to achieve the desired elastic and low stress relaxation properties. The block copolymer will generally be present in the elastomeric composition in an amount typically from about 20 to about 80 weight percent, preferably from about 30 to about 70 weight percent, and more preferably from about 40 to about 60 weight percent of the elastomeric composition.

Suitable for use in the present invention are styrene-olefin-styrene triblock copolymers such as styrene-butadiene-styrene (S-B-S), styrene-ethylene/butylene-styrene (S-EB-S), styrene-ethylene/propylene-styrene (S-EP-S), styrene-isoprene-styrene (S-I-S), hydrogenated polystyrene-isoprene/butadiene-styrene (S-IB-S) and mixtures thereof. The block copolymers may be employed alone, in a blend of block copolymers, or in a blend of one or more block copolymers with one or more other substantially less elastomeric polymers such as polypropylene, polyethylene, polybutadiene, polyisoprene, or mixtures thereof. The block copolymers employed preferably only have minor quantities of, and most preferably essentially no, such other polymers present.

Particularly preferred block copolymers for use herein are polystyrene-ethylene/butylene-polystyrene block copolymers having a styrene content in excess of about 10 weight percent. With higher styrene content, the polystyrene block portions generally have a relatively high molecular weight. Such linear block copolymers of styrene-ethylene/butylene-styrene (S-EB-S) are commercially available under the trade designation KRATON® G1600 series from the Shell Chemical Company, Huston, TX. Also preferred for use herein are polystyrene-ethylene-ethylene/propylene-styrene (S-E-EP-S) block copolymers, wherein the ethylene/propylene block is derived from selective hydrogenation of the unsaturation sites within the polystyrene-isoprene/butadiene-styrene block copolymers. Hydrogenated polystyrene-isoprene/butadiene-styrene (S-IB-S) block copolymers are commercially available under the trade designation SEPTON® 4000 series from Kuraray America, Inc. New York, NY. All the styrenic-olefinic block copolymers described herein are suitable for use in the low stress relaxation elastomeric materials either alone or in mixtures thereof.

Various thermoplastic or substantially less elastomeric or blends may be used in the low stress relaxation elastomeric material of the present invention. Suitable thermoplastic polymers should preferably associate with the hard blocks of the block copolymers to form an entangled three-dimensional network. Not intending to be bound by theory, this entangled network structure is believed to be capable of improving the tensile, elastic and stress relaxation properties. Thermoplastic polymers such as polyphenylene oxide, and vinylarene resins derived from monomers including styrene,  $\alpha$ -methyl styrene, other styrene derivatives, vinyl toluene, and mixtures thereof, are useful in the present invention. These polymers are preferred because they are chemically compatible with the styrenic hard blocks of the block copolymer. It is believed to be advantageous for the components to be compatible such that they may more easily form an entangled three-dimensional network structure, and they do not physically separate to a significant extent from the network structure.

Thermoplastic polymers useful herein as the hard block associating component should have a molecular weight in the suitable range. The thermoplastic polymers should preferably have an average molecular weight that is sufficiently high such that their glass transition temperature, tensile and elastic properties are increased. The thermoplastic polymers useful  
5 herein should also have an average molecular weight not significantly different from that of the hard blocks of the elastomeric block copolymers so that they are compatible with the hard blocks. Suitable vinylarene resins should preferably have a number-average molecular weight of about 600 to about 200,000, more preferably of about 5,000 to about 150,000, and most preferably from about 10,000 to about 100,000. Polystyrene is particularly preferred. A preferred polystyrene has  
10 a number-average molecular weight of about 40,000 to about 60,000, and is available under the tradename NOVACOR® PS 200 series from Nova Chemicals, Inc., Monaca, PA.

Not intending to be bound by theory, it is generally believed that polymers or resins useful as the hard block associating component should have glass transition temperatures ( $T_g$ ) higher than the use temperature of the elastomeric material in order to “lock in” the three  
15 dimensional network structure and provide desired properties. As the gap between the use temperature and the glass transition temperature narrows, these polymers may “disentangle” from the network structure and weaken the network structure. Consequently, the tensile, elastic and stress relaxation properties of the elastomeric material are negatively affected. These negative effects are especially pronounced in the stress relaxation properties.

20 For body temperature applications such as absorbent articles, bandages, wraps or wound dressings, which would be worn next to a person’s body for an extended period of time, it is previously believed that polymers having higher glass transition temperatures such as polyphenylene oxide, should be used. However, polyphenylene oxide is difficult to process because it has a high melting temperature and relatively high melt viscosity. Moreover, the high  
25 processing temperature required for polyphenylene oxide may result in degradation of other components in the elastomeric materials or the final products. The initial modulus of polyphenylene oxide may also be too high for stretchable articles such that undue forces need to be applied in order to put the article on the wearer.

Since vinylarene resins have glass transition temperatures significantly lower than  
30 polyphenylene oxide, it is surprising to find that vinylarene resins can be used in the elastomeric materials of the present invention to provide desired elastic and stress relaxation properties at body temperature under sustained load condition. Moreover, vinylarene resins are easy to process at relatively low temperatures such that little or no degradation of other thermoplastic or elastomeric components would occur.

Vinylarene resins useful herein as the hard block associating polymers should preferably have a glass transition temperature ranges from about 58°C to about 180°C, more preferably from about 70°C to about 150°C, more preferably from about 90°C to about 130°C.

Also useful herein as the hard block associating polymer are low molecular weight aromatic hydrocarbon resins, either alone or in blends with higher molecular weight polyvinylarenes, particularly polystyrene. The low molecular weight aromatic resins are preferably derived from vinylarene monomers. The low molecular weight resins provide lower viscosity, hence better processability of the elastomeric compositions. Not intending to be bound by theory, it is believed that the lower molecular weight resins tend to be less effective in forming the three-dimensional entanglements with the hard blocks of the elastomeric copolymers and polystyrene. And due to the low molecular weight, the resins may associate with either the elastomeric soft blocks or the thermoplastic hard blocks. In effect, incorporating the low molecular weight resins reduces the percentage of the hard, entangled networks in the composition. Therefore, it is generally believed that low molecular weight resins may be used as processing aids, but they generally provide negative effects on the elastic and stress relaxation properties of the films prepared from compositions containing these resins. It is surprising to find that elastomeric compositions containing low molecular weight aromatic hydrocarbon resins, either alone or in mixtures with polystyrenes, exhibit the desired elastic and stress relaxation properties suitable for use herein.

Typically, the ratios of polystyrene content to aromatic hydrocarbon resin content in the blends range from about 1:10 to about 10:1, preferably from about 1:4 to about 4:1. The number-average molecular weights of the aromatic hydrocarbon resins typically range from about 600 to about 10,000. The preferred aromatic hydrocarbon resins have a glass transition temperature from about 60°C to about 105°C and a number-average molecular weight of about 600 to about 4,000. The preferred aromatic hydrocarbon resins include ENDEX® 155 or 160, KRISTALEX® 3115 or 5140, PICCOTEX® 120 and PICCOLASTIC® D125, all are available from Hercules, Inc., Wilmington, DE.

The thermoplastic polymers or resin blends are generally in an amount typically from about 3 to about 60 weight percent, preferably from about 5 to about 40 weight percent, and more preferably from about 10 to about 30 weight percent of the low stress relaxation elastomeric composition used in the present invention.

Even though polystyrene, low molecular weight aromatic hydrocarbon resins and other endblock associating polymers or resins may provide lower melt viscosity and promote processability of the composition, it has been found that additional processing aid such as a

hydrocarbon oil, is beneficial for further lowering the viscosity and enhancing processability. The oil decreases the viscosity of the elastomeric composition such that the elastomeric composition becomes more processable. However, the processing oil tends to decrease the elastomeric retention and tensile properties of the compositions. Typically, the processing oil is present in an amount up to about 60 wt%, preferably from about 5 to about 60 wt%, more preferably from about 10 to about 50 wt%, and most preferably from about 15 to about 45 wt% of the elastomeric compositions.

In a preferred embodiment, the processing oil is compatible with the composition, and is substantially non-degrading at the processing temperature. Suitable for use herein are hydrocarbon oils which may be linear, branched, cyclic, aliphatic or aromatic. Preferably the processing oil is a white mineral oil available under the tradename BRITOL® from Witco Company, Greenwich, CT. Also preferred as the processing oil is another mineral oil under the tradename DRAKEOL® from Pennzoil Company Penreco Division, Karns City, PA.

In general, an elastomeric composition with desirable elastic properties may be prepared from a composition that comprises essentially only a block copolymer. However, such a composition will generally be very difficult to process because of high viscosity and high stretchy and tacky nature of the composition. In addition, the inherent tackiness of the elastomeric composition makes it difficult to handle. For example, the composition may be processed into a film which tends to stick to the processing equipment and is difficult to remove from the equipment, or when the composition have been processed and wound up, it tends to fuse together and becomes very difficult to unwound for further processing into the finished product.

It is found that blending the neat block copolymer with other thermoplastic polymers as well as processing oils improves the processability and handling of the composition. The thermoplastic polymers and processing oil tend to reduce the viscosity of the composition and provide improved processability of the composition. To further improve the processability and handling of the composition, especially when a film of such elastomeric composition is desired, at least one skin layer of a substantially less elastomeric material may be laminated with the elastomeric composition. In a preferred embodiment, the elastomeric composition is coextruded with thermoplastic compositions to provide an elastomeric center layer between two skin layers, each being substantially joined to one side of the center layer. The two skin layers may be of the same or different thermoplastic materials.

The skin layer is preferably at least partially compatible or miscible with a component of the elastomeric block copolymers such that there is sufficient adhesion between the center elastomeric layer and the skin layer for further processing and handling. The skin layer may

comprise thermoplastic polymers or blends of thermoplastic polymers and elastomeric polymers such that the skin layer is substantially less elastomeric than the center elastomeric layer. Typically, the permanent set of the skin layer is at least about 20%, preferably at least about 30%, more preferably at least about 40% greater than that of the elastomeric center layer.

5 Thermoplastic polymers suitable for use as the skin layer may be a polyolefin derived from monomers such as ethylenes, propylenes, butylenes, isoprenes, butadienes, 1,3-pentadienes,  $\alpha$ -alkenes including 1-butenes, 1-hexenes, and 1-octenes, and mixtures of these monomers, an ethylene copolymers such as ethylene-vinylacetate copolymers (EVA), ethylene-methacrylate copolymers (EMA), and ethylene-acrylic acid copolymers, a polystyrene, a poly( $\alpha$ -methyl

10 styrene), a styrenic random block copolymer (such as INDEX® interpolymers, available from Dow Chemicals, Midland, MI), a polyphenylene oxide, and blends thereof. Additionally, tie layers may be used to promote adhesion between the center elastomeric layer and the thermoplastic skin layer.

FIG. 5 is a plan view of alternative primary aperture shapes projected in the plane of the first surface of an alternative elastomeric web of the present invention. While a repeating pattern of uniform shapes is preferred, the shape of primary apertures, e.g., apertures 71, may be generally circular, polygonal, or mixed, and may be arrayed in an ordered pattern or in a random pattern. Although not shown, it is understood that the projected shape may also be elliptical, tear-drop shaped, or any other shape, that is, the present invention is believed to be aperture-shape

20 independent.

The interconnecting elements are inherently continuous, with contiguous interconnecting elements blending into one another in mutually-adjoining transition zones or portions, e.g., transition portions 87, shown in FIG. 5. In general, transition portions are defined by the largest circle that can be inscribed tangent to any three adjacent apertures. It is understood that for certain

25 patterns of apertures the inscribed circle of the transition portions may be tangent to more than three adjacent apertures. For illustrative purposes, interconnecting members may be thought of as beginning or ending substantially at the centers of the transition portions, such as interconnecting members 97 and 98. Likewise, the sidewalls of the interconnecting members can be described as interconnecting to sidewalls of contiguous interconnecting members at areas corresponding to

30 points of tangency where the inscribed circle of the transition portion is tangent to an adjoining aperture.

Exclusive of the transition zones, cross-sections transverse to a center line between the beginning and end of interconnecting members are preferably of generally uniform U-shape. However, the transverse cross-section need not be uniform along the entire length of the

interconnecting member, and for certain aperture configurations it will not be uniform along most of its length. For example, as can be understood from the sectional illustrations of FIG. 5, for interconnecting member 96, the width dimension, 86, of the base portion 81 may vary substantially along the length of the interconnecting member. In particular, in transition zones or portions 87, interconnecting members blend into contiguous interconnecting members and transverse cross-sections in the transition zones or portions may exhibit substantially non-uniform U-shapes, or no discernible U-shape.

Without wishing to be bound by theory, it is believed that the web of the present invention is more reliable (i.e., resistant to catastrophic failure) when subjected to strain-induced stress due to the mechanism depicted schematically in cross section in FIGs. 8A-8C and pictorially in photomicrographs 9 -11. FIG. 8A shows a primary aperture 71 in plane 102 of first surface 90, and a secondary aperture 72 in plane 106 of second surface 85, remote from plane 106 of first surface 90, of web 80 in an unstressed condition. When web 80 is stretched in the direction generally shown by arrows in FIG. 8B, first surface 90 is strained, and primary aperture 71 is likewise strained into a deformed configuration. However, the perimeter of primary aperture 71 is formed by the interconnecting members in a continuous first surface. Therefore, aperture 71 has no "edges" for tear initiation sites to compromise the elastic reliability of the web. The edges of the secondary aperture 72, being possible tear initiation sites, do not experience appreciable strain-induced stresses until the web is strained to the point where plane 102 is no longer remote from plane 106 of the first surface 90, as depicted in FIG. 8C. At the point where planes 102 and 106 are no longer remote, web 80 begins to behave essentially as a planar, apertured web.

It is instructive to consider the ratio of overall web depth, "D" in FIG. 8A, to film thickness, "T" in FIG. 8A of an unstretched elastomeric web. This ratio of D/T may be termed the draw ratio, as it pertains to the amount of film drawn out of the plane of the first surface due to the forming process of the present invention. Applicant believes that, in general, an increase in the draw ratio serves to increase resistance to tear by placing the second surface more remote from the first surface.

Without wishing to be bound by theory, it is believed that when the web 80 is strained or stretched, the elastomeric layer 101 of the present invention allows the base 81 of the interconnecting members forming a continuous web in the continuous first surface 90 to stretch. Skin layer 103 helps maintain the three-dimensional nature of the web, despite the applied stress, allowing the strain on the continuous first surface 90 and the resulting deformation of primary apertures 71 to be at least partially dissociated from the discontinuous second surface thereby minimizing strain at secondary apertures 72. Therefore the strain-induced stress at the continuous

first surface of the web is substantially decoupled from potential strain-induced stress at tear initiation sites on the discontinuous second surface, at least until the secondary apertures begin to enter the plane of the first surface. This substantial dissociation, or decoupling, of the strain-induced stress of the web from strain-induced stress at the secondary apertures significantly increases web reliability by allowing repeated and sustained strains of the web up to about 400% or more without failure of the web due to tear initiation at the apertures.

The photomicrographs of FIGs. 9-11 are believed to depict visually the mechanism described schematically in FIGs. 8A-8C. FIG. 9 is an optical photomicrograph showing the first surface and primary apertures of a web formed according the method described herein. In an as-formed, unextended configuration the continuous first surface of the web embodiment shown in FIG. 9 generally forms a regular pattern of 1 mm square primary apertures spaced about 1 mm apart on all sides. FIGs. 10 and 11 are scanning electron microscope photomicrographs showing the discontinuous second surface of the web embodiment of FIG. 9, shown at a slightly different scale. FIG. 10 shows the second surface of an elastomeric web generally in a plane remote from the plane of the first surface in an unstretched state. FIG. 11 shows the second surface of a web in a state of approximately 100% elongation. As shown in FIG. 11, the edges of the secondary apertures remain remote from the plane of the first surface. Although some distortion of the secondary apertures takes place, the edges remain in a substantially unstressed condition. Again, it is this substantial decoupling of the strain-induced stress of the web from strain-induced stress at the secondary apertures that significantly increases web reliability.

The differential elastic behavior of planar multilayer films or fibers having a relatively less elastic skin layer stretched beyond its elastic limit is known in the art, as described in the aforementioned U.S. Patent to Krueger et al., as well as in U.S. Patent Nos. 5,376,430 to Swenson et al., issued Dec. 27, 1994 and 5,352,518 to Muramoto et al., issued Oct. 4, 1994. As shown in the art, upon recovery after extension beyond the elastic limits of the skin layer, the skin layer may form a microscopic microtexture of peak and valley irregularities, due to the resulting increased surface area of the skin layer relative to the elastomeric layer.

Likewise, when a web of the present invention is strained for the first time, the skin layer of the strained portion may be stressed beyond its elastic limit. The elastomeric layer allows the web to return substantially to its pre-stressed, macroscopic, three-dimensional configuration, but the portions of the skin layer that were stressed beyond their elastic limit may not return to a pre-stressed configuration due to the excess material created in the inelastic strain. Upon recovery after extension, the skin layer forms microscopic microtexture of peak and valley irregularities, more generally described as transversely-extending rugosities, as shown in the photomicrograph of FIG. 12. The rugosities form on the interconnecting members in substantially uniform patterns



generally transverse to the direction of stretch, and generally radially disposed about the primary apertures. Depending on the degree of strain on the web, the rugosities may be limited to substantially the continuous first surface of the web, or more generally may extend over substantially the entire surface of the interconnecting members.

5 Without being bound by theory, it is believed that the transversely-extending rugosities are beneficial to the elastomeric web for at least two reasons. First, the rugosities impart a softer overall texture or feel to the elastomeric web. Second, the rugosities, being radially disposed to the primary apertures, and extending toward the secondary apertures, may facilitate better fluid handling characteristics when used as a body-contacting web of a disposable absorbent article.

10 A representative embodiment of an elastomeric web of the present invention utilized in a disposable absorbent article in the form of a diaper **400**, is shown in FIG. 13. As used herein, the term "diaper" refers to a garment generally worn by infants and incontinent persons that is worn about the lower torso of the wearer. It should be understood, however, that the elastomeric web of the present invention is also applicable to other absorbent articles such as incontinent briefs,  
15 training pants, sanitary napkins, and the like. The diaper **400** depicted in FIG. 13 is a simplified absorbent article that could represent a diaper prior to its being placed on a wearer. It should be understood, however, that the present invention is not limited to the particular type or configuration of diaper shown in FIG. 13. A particularly preferred representative embodiment of a disposable absorbent article in the form of a diaper is taught in U.S. Pat. No. 5,151,092, to Buell  
20 et al., issued September 29, 1992, being hereby incorporated herein by reference.

FIG. 13 is a perspective view of the diaper **400** in its uncontracted state (i.e., with all the elastic induced contraction removed) with portions of the structure being cut-away to more clearly show the construction of the diaper **400**. The portion of the diaper **400** which contacts the wearer faces the viewer. The diaper **400** is shown in FIG. 13 to preferably comprise a liquid pervious  
25 topsheet **404**; a liquid impervious backsheet **402** joined with the topsheet **404**; and an absorbent core **406** positioned between the topsheet **404** and the backsheet **402**. Additional structural features such as elastic leg cuff members and fastening means for securing the diaper in place upon a wearer may also be included.

While the topsheet **404**, the backsheet **402**, and the absorbent core **406** may be assembled in  
30 a variety of well known configurations, preferred diaper configurations are described generally in U.S. Pat. No. 3,860,003 entitled "Contractible Side Portions for Disposable Diaper" which issued to Kenneth B. Buell on January 14, 1975; U.S. Pat. No. 5,151,092 issued to Buell on September 9, 1992; and U.S. Pat. No. 5,221,274 issued to Buell on June 22, 1993; and U.S. Pat. No. 5,554,145 entitled "Absorbent Article With Multiple Zone Structural Elastic-Like Film Web

Extensible Waist Feature" which issued to Roe et al. on September 10, 1996; U.S. Pat. No. 5,569,234 entitled "Disposable Pull-On Pant" which issued to Buell et al. on October 29, 1996; U.S. Pat. No. 5,580,411 entitled "Zero Scrap Method For Manufacturing Side Panels For Absorbent Articles" which issued to Nease et al. on December 3, 1996; and U.S. Patent  
5 Application Serial No. 08/915,471 entitled "Absorbent Article With Multi-Directional Extensible Side Panels" filed August 20, 1997 in the name of Roble et al.; each of which is incorporated herein by reference.

FIG. 13 shows a representative embodiment of the diaper **400** in which the topsheet **404** and the backsheet **402** are co-extensive and have length and width dimensions generally larger  
10 than those of the absorbent core **406**. The topsheet **404** is joined with and superimposed on the backsheet **402** thereby forming the periphery of the diaper **400**. The periphery defines the outer perimeter or the edges of the diaper **400**. The periphery comprises the end edges **401** and the longitudinal edges **403**.

The size of the backsheet **402** is dictated by the size of the absorbent core **406** and the exact  
15 diaper design selected. In a preferred embodiment, the backsheet **402** has a modified hourglass-shape extending beyond the absorbent core **406** a minimum distance of at least about 1.3 centimeters to about 2.5 centimeters (about 0.5 to about 1.0 inch) around the entire diaper periphery.

The topsheet **404** and the backsheet **402** are joined together in any suitable manner. As  
20 used herein, the term "joined" encompasses configurations whereby the topsheet **404** is directly joined to the backsheet **402** by affixing the topsheet **404** directly to the backsheet **402**, and configurations whereby the topsheet **404** is indirectly joined to the backsheet **402** by affixing the topsheet **404** to intermediate members which in turn are affixed to the backsheet **402**. In a preferred embodiment, the topsheet **404** and the backsheet **402** are affixed directly to each other in  
25 the diaper periphery by attachment means (not shown) such as an adhesive or any other attachment means as known in the art. For example, a uniform continuous layer of adhesive, a patterned layer of adhesive, or an array of separate lines or spots of adhesive can be used to affix the topsheet **404** to the backsheet **402**.

End edges **401** form a waist region, which in a preferred embodiment comprise a pair of  
30 elastomeric side panels **420**, which extend laterally from end edges **401** of diaper **400** in an extended configuration. In a preferred embodiment elastomeric side panels **420** comprise the elastomeric web of the present invention. In an especially preferred embodiment, when used as elastomeric side panels, the web of the present invention is further processed to form a composite laminate by bonding it on one, or preferably both sides thereof, with fibrous nonwoven materials

to form a soft, compliant elasticized member, utilizing methods known in the art, such as adhesive bonding.

Fibrous nonwoven materials suitable for use in a composite laminate of the present invention include nonwoven webs formed of synthetic fibers (such as polypropylene, polyester, or polyethylene), natural fibers (such as wood, cotton, or rayon), or combinations of natural and synthetic fibers. Suitable nonwoven materials can be formed by various processes such as carding, spun-bonding, hydro-entangling, and other processes familiar to those knowledgeable in the art of nonwovens. A presently preferred fibrous nonwoven material is carded polypropylene, commercially available from Fiberweb of Simpsonville, S.C.

Fibrous nonwoven materials may be bonded to the elastomeric web by any one of various bonding methods known in the art. Suitable bonding methods include adhesive bonding such as by a uniform continuous layer of adhesive, a patterned layer of adhesive, or an array of separate lines, spirals, or spots of adhesive, or other methods such as heat bonds, pressure bonds, ultrasonic bonds, dynamic mechanical bonds, or any other suitable attachment means or combinations of these attachment means as are known in the art. Representative bonding methods are also described in U.S. SIR No. H1670, entitled "Absorbent Article Having a Nonwoven and Apertured Film Coversheet" by Aziz et al., published July 1, 1997, and being hereby incorporated herein by reference.

After bonding to a fibrous nonwoven material, the composite web may tend to be less elastomeric due to the relative inelasticity of the bonded nonwoven. To render the nonwoven more elastic, and to restore elasticity to the composite laminate, the composite web may be processed by methods and apparatus used for elasticizing "zero strain" laminates by incremental stretching, as disclosed in the aforementioned Buell et al. '092 patent, as well as the aforementioned Weber et al. '897, Buell et al. '793, and Weber et al. '679 patents. The resulting elasticized "zero-strain" composite web then has a soft, cloth-like feel for extended use and comfortable fit in an absorbent garment.

Side panels **420** may be joined to the diaper in any suitable manner known in the art. For example, as shown in FIG. 13, side panels **420** may be affixed directly to the backsheet **402** by attachment means (not shown) such as an adhesive or any other attachment means as known in the art. A particularly preferred configuration for side panels **420** is shown in FIG. 14, a configuration which is more fully disclosed in commonly assigned U.S. Pat. No. 5,669,897, issued September 23, 1997 to LaVon et al., and U.S. Patent Application S.N. 08/155,048, filed November, 19, 1993 by Roles et al., the disclosures of both being hereby incorporated herein by reference.

As shown in FIG. 14, side panel 420 is preferably comprised of two webs or strips, 421 and 422. Strips 421 and 422 may be two discrete strips, or alternatively they may be formed by bending a single strip at leading edge 424, and offsetting the two resulting strip lengths in a non-parallel manner. If two discrete strips are used, they may be bonded, as with suitable adhesive, to one another at leading edge 424, and may simultaneously be bonded to tape tab 423. Side panel 420 may be bonded to backsheet 402 at bond area 425 in any suitable manner, and particularly as disclosed in the aforementioned LaVon et al. '879 patent. While it is not necessary that the pairs of side panels be identical, they are preferably mirror images one of the other. Other examples of diapers with elasticized side panels are disclosed in U.S. Patent 4,857,067, entitled "Disposable Diaper Having Shirred Ears" issued to Wood, et al. on August 15, 1989; U.S. Patent 4,381,781 issued to Sciaraffa, et al. on May 3, 1983; U.S. Patent 4,938,753 issued to Van Gompel, et al. on July 3, 1990; the herein before referenced U.S. Pat. No. 5,151,092 issued to Buell on September 9, 1992; and U.S. Pat. No. 5, 221,274 issued to Buell on June 22, 1993; U.S. Patent No. 5,669,897 issued to LaVon, et al. on September 23, 1997 entitled "Absorbent Articles Providing Sustained Dynamic Fit"; U.S. Pat. No. 5,897,545 issued to Kline, et. al. on April 27, 1999; U.S. Patent Application Serial No. 08/155,048 entitled "Absorbent Article With Multi-Directional Extensible Side Panels" filed November 19, 1993 in the names of Roble, et al.; each of which is incorporated herein by reference.

The diaper 400 may also include a fastening system 423. The fastening system 423 preferably maintains waist regions 401 in an overlapping configuration so as to provide lateral tensions about the circumference of the diaper 400 to hold the diaper 400 on the wearer. The fastening system 423 preferably comprises tape tabs and/or hook and loop fastening components, although any other known fastening means are generally acceptable. Some exemplary fastening systems are disclosed in U.S. Patent 3,848,594 entitled "Tape Fastening System for Disposable Diaper" issued to Buell on November 19, 1974; U.S. Patent 4,662,875 entitled "Absorbent Article" issued to Hirotsu et al. on May 5, 1987; U.S. Patent 4,846,815 entitled "Disposable Diaper Having An Improved Fastening Device" issued to Scripps on July 11, 1989; U.S. Patent 4,894,060 entitled "Disposable Diaper With Improved Hook Fastener Portion" issued to Nestegard on January 16, 1990; U.S. Patent 4,946,527 entitled "Pressure-Sensitive Adhesive Fastener And Method of Making Same" issued to Battrell on August 7, 1990; and the herein before referenced U.S. Pat. No. 5,151,092 issued to Buell on September 9, 1992; and U.S. Pat. No. 5,221,274 issued to Buell on June 22, 1993. The fastening system may also provide a means for holding the article in a disposal configuration as disclosed in U.S. Pat. No. 4,963,140 issued to Robertson et al. on October 16, 1990. The fastening system may also include primary and

secondary fastening systems, as disclosed in U.S. Pat. No. 4,699,622 to reduce shifting of overlapped portions or to improve fit as disclosed in U.S. Pat. No.'s 5,242,436; 5,499,978; 5,507,736; 5,591,152. Each of these patents is incorporated herein by reference. In alternative embodiments, opposing sides of the garment may be seamed or welded to form a pant. This  
5 allows the article to be used as a pull-on diaper or training pant.

Other elastic members (not shown), of the present invention may be disposed adjacent the periphery of the diaper **400**. Elastic members are preferably along each longitudinal edge **403**, so that the elastic members tend to draw and hold the diaper **400** against the legs of the wearer. In addition, the elastic members can be disposed adjacent either or both of the end edges **401** of the  
10 diaper **400** to provide a waistband as well as or rather than leg cuffs. For example, a suitable waistband is disclosed in U.S. Patent 4,515,595 to Kievit et al., issued May 7, 1985, the disclosure of which is hereby incorporated by reference. In addition, a method and apparatus suitable for manufacturing a disposable diaper having elastically contractible elastic members is described in U.S. Patent 4,081,301 to Buell, issued March 28, 1978, the disclosure of which is hereby  
15 incorporated herein by reference.

The elastic members are secured to the diaper **400** in an elastically contractible condition so that in a normally unrestrained configuration, the elastic members effectively contract or gather the diaper **400**. The elastic members can be secured in an elastically contractible condition in at least two ways. For example, the elastic members can be stretched and secured while the diaper  
20 **400** is in an uncontracted condition. In addition, the diaper **400** can be contracted, for example, by pleating, and the elastic members secured and connected to the diaper **400** while the elastic members are in their relaxed or unstretched condition. The elastic members may extend along a portion of the length of the diaper **400**. Alternatively, the elastic members can extend the entire length of the diaper **400**, or any other length suitable to provide an elastically contractible line.  
25 The length of the elastic members is dictated by the diaper design.

The elastic members can be in a multitude of configurations. For example, the width of the elastic members can be varied from about 0.25 millimeters (0.01 inches) to about 25 millimeters (1.0 inch) or more; the elastic members can comprise a single strand of elastic material or can comprise several parallel or non-parallel strands of elastic material; or the elastic members can be  
30 rectangular or curvilinear. Still further, the elastic members can be affixed to the diaper in any of several ways which are known in the art. For example, the elastic members can be ultrasonically bonded, heat and pressure sealed into the diaper **400** using a variety of bonding patterns or the elastic members can simply be glued to the diaper **400**.

As shown in FIG. 13, the absorbent core **406** preferably includes a fluid distribution member **408**. In a preferred configuration such as depicted in FIG. 13, the absorbent core **406** preferably further includes an acquisition layer or member **410** in fluid communication with the fluid distribution member **408** and located between the fluid distribution member **408** and the topsheet **404**. The acquisition layer or member **410** may be comprised of several different materials including nonwoven or woven webs of synthetic fibers including polyester, polypropylene, or polyethylene, natural fibers including cotton or cellulose, blends of such fibers, or any equivalent materials or combinations of such materials.

In use, the diaper **400** is applied to a wearer by positioning the back waistband region under the wearer's back, and drawing the remainder of the diaper **400** between the wearer's legs so that the front waistband region is positioned across the front of the wearer. The elastomeric side panels are then extended as necessary for comfort and fit, and the tape-tab or other fasteners are then secured preferably to outwardly facing areas of the diaper **400**. By having side panels **420** comprising an elastomeric web of the present invention, the diaper may be adapted for differing sizes of children, for example, in a manner providing for close, comfortable fit with breathability.

While a disposable diaper is shown as a preferred embodiment of a garment comprising an elastomeric web of the present invention, this disclosure is not meant to be limiting to disposable diapers. Other disposable garments may also incorporate an elastomeric web of the invention in various parts to give added comfort, fit and breathability. As well, it is contemplated that even durable garments such as undergarments and swimwear may benefit from the durable porous, extensible characteristics of an elastomeric web of the present invention.

The multilayer film **120** of the present invention may be processed using conventional procedures for producing multilayer films on conventional coextruded film-making equipment. In general, polymers can be melt processed into films using either cast or blown film extrusion methods both of which are described in "Plastics Extrusion Technology" 2nd Ed., by Allan A. Griff (Van Nostrand Reinhold-1976), which is hereby incorporated herein by reference. Cast film is extruded through a linear slot die. Generally, the flat web is cooled on a large moving polished metal roll. It quickly cools, and peels off the first roll, passes over one or more auxiliary rolls, then through a set of rubber-coated pull or "haul-off" rolls, and finally to a winder.

In blown film extrusion the melt is extruded upward through a thin annular die opening. This process is also referred to as tubular film extrusion. Air is introduced through the center of the die to inflate the tube and causes it to expand. A moving bubble is thus formed which is held at constant size by control of internal air pressure. The tube of film is cooled by air blown

through one or more chill rings surrounding the tube. The tube is next collapsed by drawing it into a flattened frame through a pair of pull rolls and into a winder.

A coextrusion process requires more than one extruder and either a coextrusion feedblock or a multi-manifold die system or combination of the two to achieve the multilayer film structure. U.S. Pat. Nos. 4,152,387 and 4,197,069, issued May 1, 1979 and April 8, 1980, respectively, both to Cloeren, are hereby incorporated herein by reference, disclose the feedblock principle of coextrusion. Multiple extruders are connected to the feedblock which employs moveable flow dividers to proportionally change the geometry of each individual flow channel in direct relation to the volume of polymer passing through said flow channels. The flow channels are designed such that at their point of confluence, the materials flow together at the same flow rate and pressure eliminating interfacial stress and flow instabilities. Once the materials are joined in the feedblock, they flow into a single manifold die as a composite structure. It is important in such processes that the melt viscosities and melt temperatures of the material do not differ too greatly. Otherwise flow instabilities can result in the die leading to poor control of layer thickness distribution in the multilayer film.

An alternative to feedblock coextrusion is a multi-manifold or vane die as disclosed in aforementioned U.S. Pat. Nos. 4,152,387, 4,197,069, as well as U.S. No. 4,533,308, issued August 6, 1985 to Cloeren, hereby incorporated herein by reference. Whereas in the feedblock system melt streams are brought together outside and prior to entering the die body, in a multi-manifold or vane die each melt stream has its own manifold in the die where the polymers spread independently in their respective manifolds. The melt streams are married near the die exit with each melt stream at full die width. Moveable vanes provide adjustability of the exit of each flow channel in direct proportion to the volume of material flowing through it, allowing the melts to flow together at the same linear flow rate, pressure, and desired width.

Since the melt flow properties and melt temperatures of polymers vary widely, use of a vane die has several advantages. The die lends itself toward thermal isolation characteristics wherein polymers of greatly differing melt temperatures, for example up to 175° F. (80° C.), can be processed together.

Each manifold in a vane die can be designed and tailored to a specific polymer. Thus the flow of each polymer is influenced only by the design of its manifold, and not forces imposed by other polymers. This allows materials with greatly differing melt viscosities to be coextruded into multilayer films. In addition, the vane die also provides the ability to tailor the width of individual manifolds, such that an internal layer can be completely surrounded by the outer layer leaving no exposed edges. The aforementioned patents also disclose the combined use of feedblock systems and vane dies to achieve more complex multilayer structures.

The multilayer films of the present invention may comprise two or more layers, at least one of the layers being elastomeric. It is also contemplated that multiple elastomeric layers may be utilized, each elastomeric layer being joined to one or two skin layers. In a three-layer film, core layer **101** has opposed first and second sides, one side being substantially continuously joined to one side of each outer skin layer **103** prior to the application of applied stress to the web. Three-layer films, like multilayer film **120** shown in FIG. 4, preferably comprise a central elastomeric core **101** that may comprise from about 10 to 90 percent of the total thickness of the film. Outer skin layers **103** are generally, but not necessarily, identical and may comprise from about 5 to 45 percent of the total thickness of the film. Although an elastomeric layer is generally substantially joined to one or two skin layers without the use of adhesives, adhesives or tie layers may be used to promote adherence between the layers. Tie layers, when employed, may each comprise from about 5 to 10 percent of the total film thickness.

After the multilayer elastomeric film has been coextruded it is preferably fed to a forming structure for aperturing and cooling, thereby producing a macroscopically-expanded, three-dimensional, apertured elastomeric web of the present invention. In general the film may be formed by drawing such film against a forming screen or other forming structure by means of a vacuum and passing an air or water stream over the outwardly posited surface of the film. Such processes are described in the aforementioned Radel et al. patent as well as in U.S. Pat. No. 4,154,240, issued to Lucas et al., both hereby incorporated herein by reference. Forming a three-dimensional elastomeric web may alternatively be accomplished by applying a liquid stream with sufficient force and mass flux to cause the web formation as disclosed in commonly assigned U.S. Pat. No. 4,695,422, issued to Curro et al. and hereby incorporated herein by reference. Alternatively, the film can be formed as described in commonly assigned U.S. Pat. No. 4,552,709 to Koger et al., and hereby incorporated herein by reference. Preferably the elastomeric web is uniformly macroscopically expanded and apertured by the method of supporting the forming structure in a fluid pressure differential zone by a stationary support member as taught by commonly assigned U.S. Pat. Nos. 4,878,825 and 4,741,877, both to Mullane, Jr., and hereby incorporated herein by reference.

Although not shown, the process of the present invention, using a conventional forming screen having a woven wire support structure, would also form a web within the scope of the present invention. The knuckles of a woven wire forming screen would produce a macroscopically-expanded, three-dimensional web having a pattern of undulations in the first surface, the undulations corresponding to the knuckles of the screen. However, the undulations would remain generally in the plane of the first surface, remote from the plane of the second



surface. The cross-section of the interconnecting members would remain generally upwardly concave-shaped with the interconnecting sidewalls of the interconnecting members terminating to form secondary apertures substantially in the plane of the second surface.

5 A particularly preferred forming structure comprises a photoetched laminate structure as shown in FIG. 15, showing an enlarged, partially segmented, perspective illustration of a photoetched laminate structure of the type used to form plastic webs of the type generally illustrated in FIG. 2. The laminate structure 30 is preferably constructed generally in accordance with the teachings of the aforementioned Radel et al. patent, and is comprised of individual lamina 31, 32, and 33. A comparison of FIG. 3 with the elastomeric web 80 shown in FIG. 2 reveals the  
10 correspondence of primary aperture 71 in plane 102 of the elastomeric web 80 to opening 61 in the uppermost plane 62 of the photoetched laminate structure 30. Likewise, aperture opening 72 in plane 106 of elastomeric web 80 corresponds to opening 63 in lowermost plane 64 of photoetched laminate structure 30.

The uppermost surface of photoetched laminate structure 30 located in uppermost plane 62  
15 may be provided with a microscopic pattern of protuberances 48 without departing from the scope of the present invention. This is preferably accomplished by applying a resist coating which corresponds to the desired microscopic pattern of surface aberrations to the top side of a planar photoetched lamina 31, and thereafter initiating a second photoetching process. The second photoetching process produces a lamina 31 having a microscopic pattern of protuberances 48 on  
20 the uppermost surface of the interconnected elements defining the pentagonally shaped apertures, e.g., aperture 41. The microscopic pattern of protuberances does not substantially remove the first surface from the plane of the first surface. The first surface is perceived on a macroscopic scale, while the protuberances are perceived on a microscopic scale. Construction of a laminate structure employing such a pattern of protuberance 48 on its uppermost layer is generally  
25 disclosed in the aforementioned Ahr et al. patent.

Processes for constructing laminate structures of the type generally disclosed in FIG. 2 are disclosed in the aforementioned Radel et al. patent. The photoetched laminate structures are preferably rolled by conventional techniques into a tubular forming member 520, as illustrated generally in FIG. 16 and their opposing ends joined generally in accordance with the teachings of  
30 Radel et al. to produce a seamless tubular forming member 520.

The outermost surface 524 of the tubular forming member 520 is utilized to form the multilayer elastomeric web brought in contact therewith while the innermost surface 522 of the tubular member generally does not contact the plastic web during the forming operation. The tubular member may, in a preferred embodiment of the present invention, be employed as the

forming surface on debossing/perforating cylinder 555 in a process of the type described in detail in the aforementioned Lucas et al. patent. A particularly preferred apparatus 540 of the type disclosed in said patent is schematically shown in FIG. 17. It includes debossing and perforating means 543, and constant tension film forwarding and winding means 545 which may, if desired, be substantially identical to and function substantially identically to the corresponding portions of the apparatus shown and described in U.S. Pat. No. 3,674,221 issued to Riemersma on July 4, 1972 and which is hereby incorporated herein by reference. The frame, bearing, supports and the like which must necessarily be provided with respect to the functional members of apparatus 540 are not shown or described in detail in order to simplify and more clearly depict and disclose the present invention, it being understood that such details would be obvious to persons of ordinary skill in the art of designing plastic film converting machinery.

Briefly, apparatus 540, schematically shown in FIG. 17, comprises means for continuously receiving a ribbon of thermoplastic film 550 from coextruder 559, for example, and converting it into a debossed and perforated film 551. Film 550 is preferably supplied directly from the coextrusion process while still above its thermoplastic temperature so as to be vacuum formed prior to cooling. Alternatively, film 550 may be heated by directing hot air jets against one surface of the film while applying vacuum adjacent the opposite surface of the film. To maintain sufficient control of film 550 to substantially obviate wrinkling and/or macroscopically distending the film, apparatus 540 comprises means for maintaining constant machine direction tension in the film both upstream and downstream of a zone where the temperature is greater than the thermoplastic temperature of the film, but in which zone there is substantially zero machine direction and cross-machine direction tension tending to macroscopically distend the film. The tension is required to control and smooth a running ribbon of thermoplastic film; the zero tension zone results from the film in the zone being at a sufficiently high temperature to enable debossing and perforating the film.

As can be seen in FIG. 17, the debossing and perforating means 543 includes a rotatably mounted debossing perforating cylinder 555 having closed ends 580, a nonrotating triplex vacuum manifold assembly 556 and optional hot air jet means (not shown). The triplex vacuum manifold assembly 556 comprises three manifolds designated 561, 562, and 563. Also shown in FIG. 17 is a power rotated lead-off/chill roll 566 and a soft-face (e.g., low density neoprene) roll 567 which is driven with the chill roll. Briefly, by providing means (not shown) for independently controlling the degree of vacuum in the three vacuum manifolds, a thermoplastic ribbon of film running circumferentially about a portion of the debossing-perforating cylinder 555 is sequentially subjected to a first level of vacuum by manifold 561, a second level of vacuum by manifold 562,

and a third level of vacuum by manifold 563. As will be described more fully hereinafter, the vacuum applied to the film by manifold 561 enables maintaining upstream tension in the film, vacuum applied by manifold 562 enables perforating the film, and vacuum applied by manifold 563 enables cooling the film to below its thermoplastic temperature and enables establishing  
5 downstream tension therein. If desired, the film contacting surface of the debossing-perforating cylinder 555 may be preheated prior to reaching vacuum manifold 562 by means well known in the art (and therefore not shown) to facilitate better conformance of plastic films comprised of flow-resistant polymers during the debossing operation. The nip 570 intermediate chill roll 566 and the soft-face roll 567 is only nominally loaded because high pressure would iron-out the  
10 three-dimensional debossments which are formed in the film in the aforementioned manner. However, even nominal pressure in nip 570 helps the vacuum applied by manifold 563 to isolate downstream tension (i.e., roll winding tension) from the debossing-perforating portion of the debossing-perforating cylinder 555, and enables the nip 570 to peel the debossed and perforated film from the debossing-perforating cylinder 555. Moreover, while vacuum drawn ambient air  
15 passing through the film into manifold 563 will normally cool the film to below its thermoplastic temperature, the passage of coolant through the chill roll as indicated by arrows 573, 574 in FIG. 17 will enable the apparatus to handle thicker films or be operated at higher speeds.

The debossing and perforating means 543 comprises the rotatably mounted debossing-perforating cylinder 555, means (not shown) for rotating the cylinder 555 at a controlled  
20 peripheral velocity, the non-rotating triplex vacuum manifold assembly 556 inside the debossing-perforating cylinder 555, means (not shown) for applying controlled levels of vacuum inside the three vacuum manifolds 561, 562 and 563 comprising the triplex manifold assembly 556, and optional hot air jet means (not shown). The debossing-perforating cylinder 555 may be constructed by generally following the teachings of the aforementioned Lucas et al. patent, but  
25 substituting a tubular laminate forming surface of the present invention for the perforated tubular forming surface disclosed therein.

To summarize, the first vacuum manifold 561, and the third vacuum manifold 563 located within the debossing-perforating cylinder 555 enable maintaining substantially constant upstream and downstream tension, respectively, in a running ribbon of film while the intermediate portion  
30 of the film adjacent the second vacuum manifold 562 within the debossing-perforating cylinder 555 is subjected to tension vitiating heat and vacuum to effect debossing and perforating of the film.

While a preferred application of the disclosed photoetched laminate structure is in a vacuum film forming operation as generally outlined in the aforementioned commonly assigned patent

issued to Lucas et al., it is anticipated that photoetched laminate forming structures of the present invention could be employed with equal facility to directly form a three-dimensional plastic structure of the present invention. Such a procedure would involve applying a heated fluid plastic material, typically a thermoplastic resin, directly to the forming surface applying a sufficiently great pneumatic differential pressure to the heated fluid plastic material to cause said material to conform to the image of the perforate laminate forming surface, allowing the fluid material to solidify, and thereafter removing the three-dimensional plastic structure from the forming surface.

While the web embodiment generally disclosed in FIG. 2 represents a particularly preferred embodiment of the present invention, any number of interconnecting members may be employed within web structures of the present invention, e.g., secondary, tertiary, etc. An example of such a structure is shown in FIG. 18 which also shows a variant of upwardly concave-shaped cross-sections of interconnecting members. The aperture network shown in FIG. 18 comprises a primary aperture 301 formed by a multiplicity of primary interconnecting elements, e.g., elements 302, 303, 304 and 305 interconnected to one another in uppermost plane 307 of the web 300, said opening being further subdivided into smaller secondary apertures 310 and 311 by secondary interconnecting member 313 at an intermediate plane 314. Primary aperture 310 is further subdivided by tertiary interconnecting member 320 into even smaller secondary apertures 321 and 322, respectively, at a still lower plane 325 within web 300. As can be seen from FIG. 19, which is taken along section line 19-19 of FIG. 18, planes 314 and 325 are generally parallel to and located intermediate uppermost plane 307 and lowermost plane 330.

In the web embodiment illustrated in FIG 17 and 18, the primary and secondary interconnecting members are further connected to intersecting tertiary interconnecting members, e.g., tertiary interconnecting members 320, which also exhibit a generally upwardly concave-shaped cross-section along their length. The intersecting primary, secondary and tertiary interconnecting members terminate substantially concurrently with one another in the plane 330 of the second surface 332 to form a multiplicity of openings or apertures in the web's second surface, e.g., apertures 370, 371 and 372. It is clear that the interconnected primary, secondary and tertiary interconnecting members located between the first and second surfaces of the web 300 form a closed network connecting each of the primary apertures, e.g., aperture 301 in the first surface 331 of the web, with a multiplicity of secondary apertures, e.g., apertures 370, 371 and 372, in the second surface 332 of the web.

As will be appreciated, the generally upwardly concave-shaped interconnecting members utilized in webs of the present invention may be substantially straight along their entire length. Alternatively, they may be curvilinear, they may comprise two or more substantially straight

segments or they may be otherwise oriented in any desired direction along any portion of their length. There is no requirement that the interconnecting members be identical to one another. Furthermore, the aforementioned shapes may be combined in any desired fashion to produce whatever pattern is desired. Regardless of the shape ultimately selected, the upwardly concave-shaped cross-section which exists along the respective lengths of the interconnected interconnecting members helps impart resilience to elastomeric webs of the present invention, as well as three-dimensional standoff.

It will be obvious to those skilled in the art that various changes and modifications can be made without departing from the spirit and scope of the present invention. For example, in the event it is desired to produce webs of the present invention wherein a predetermined portion of the web is capable of preventing fluid transmission, it is feasible to perform the debossing operation without causing rupture of the web in its second surface. Commonly assigned U.S. Pat. No. 4,395,215 issued to Bishop on July 26, 1983 and commonly assigned U.S. Pat. No. 4,747,991 issued to Bishop on May 31, 1988, each of which are hereby incorporated herein by reference, fully disclose how to construct tubular forming structures which are capable of producing three-dimensionally expanded films which are uniformly debossed, but apertured only in predetermined areas.

It is believed that the description contained herein will enable one skilled in the art to practice the present invention in many and varied forms. Nonetheless, the following exemplary embodiments and analytical methods are set forth for the purpose of illustrating the beneficial elastic reliability of particularly preferred low stress relaxation elastomeric materials of the present invention.

## TEST METHODS

### A. TENSILE STRENGTH AND ELONGATION AT FAILURE

The properties determined by this method may correlate with the stretchability of the elastomeric film. These properties are relevant to the choice of material suitable for use as the elastic component of an absorbent article, particularly pull-on diapers, training pants, disposable diapers with fasteners, or other absorbent garments for adult use, that is substantially stretched when being put on.

A commercial tensile tester from Instron Engineering Corp., Canton, MA or SINTECH-MTS Systems Corporation, Eden Prairie, MN may be used for this test. The films are cut into 1" wide in MD (the machine direction of the film) by 4" long in CD (the cross direction which is at a 90° angle from MD) specimens. The instrument is interfaced with a computer for controlling the test speed and other test parameters, and for collecting, calculating and reporting the data. The

tensile stress-strain properties of the film are determined according to ASTM Method D882-83. These tensile properties are measured at room temperature (about 20°C). The procedure is as follows:

- 5 (1) choose appropriate jaws and load cell for the test; the jaws should be wide enough to fit the sample, typically 1" wide jaws are used; the load cells is chosen so that the tensile response from the sample tested will be between 25% and 75% of the capacity of the load cells or the load range used, typically a 50 lb load cell is used;
- (2) calibrate the instrument according to the manufacture's instructions;
- (3) set the gauge length at 2";
- 10 (4) place the sample in the flat surface of the jaws according to the manufacture's instructions;
- (5) set the cross head speed at a constant speed of 20"/min;
- (6) start the test and collect data simultaneously; and
- (7) calculate and report tensile properties including elongation at break, and load at 100%  
15 and 200% elongation. The average result of three samples is reported.

#### B. Two Cycle Hysteresis Test

The properties determined by this method may correlate with the forces consumer feels from the side panel, waist band, or other elastic components when initially applying the product and how the product fits after it has been put on.

A commercial tensile tester from Instron Engineering Corp., Canton, MA or SINTECH-MTS Systems Corporation, Eden Prairie, MN may be used for this test. The films are cut into specimens 1" wide in MD by 4" long in CD. The instrument is interfaced with a computer for controlling the test speed and other test parameters, and for collecting, calculating and reporting the data. The two cycle hysteresis is measured at room temperature. The procedure is as follows:

- 25 (1) choose appropriate jaws and load cell for the test; the jaws should be wide enough to fit the sample, typically 1"wide jaws are used; the load cells is chosen so that the response from the sample tested will be between 25% and 75% of the capacity of the load cells or the load range used, typically a 50 lb load cell is used;
- 30 (2) calibrate the instrument according to the manufacture's instructions;
- (3) set the gauge length at 2";
- (4) place the sample in the flat surface of the jaws according to the manufacture's instructions;
- (5) set the cross head speed at a constant speed of 20"/min;

(6) start the two cycle hysteresis test and collect data simultaneously, the two cycle hysteresis test has the following steps:

- a) go to 200% elongation at the constant rate of 20"/min;
- b) hold position for 30 seconds;
- 5 c) go to 0% strain at the constant speed of 20"/min;
- d) hold position for 60 seconds;
- e) go to 50% elongation at the constant speed of 20"/min;
- f) hold position for 30 seconds; and
- g) go to 0% strain; and

10 (7) calculate and report properties including stress relaxation at 200% elongation, and percent set. The average result of three samples is reported.

#### C. Sustained Load Stress Relaxation Test

The properties determined by this method may correlate with the forces consumer feels  
15 from the side panel, waist band, or other elastic components of the product and how the product fits at body temperature after it has been worn for a specified period of time. The properties determined by this method is relevant to the choice of materials that resist relaxation under sustained load at body temperature (approximately 100°F), hence provide sustained fit over the maximum wear time of an absorbent article.

20 A commercial tensile tester from Instron Engineering Corp., Canton, MA or SINTECH-MTS Systems Corporation, Eden Prairie, MN may be used for this test. The films are cut into specimens 1" wide in MD by 2" long in CD. Mark 1" gauge length on the sample and wrap tapes around the sample outside the gauge length marks to provide better surface for gripping by the jaws. The instrument is interfaced with a computer for controlling the test speed and other test  
25 parameters, and for collecting, calculating and reporting the data. The sustained load stress relaxation is measured at 100°F (about human body temperature). The procedure is as follows:

- (1) choose appropriate jaws and load cell for the test; the jaws should be wide enough to fit the sample, typically 1" wide jaws are used; the load cells is chosen so that the response from the sample tested will be between 25% and 75% of the capacity of the  
30 load cells or the load range used, typically a 50 lb load cell is used;
- (2) calibrate the instrument according to the manufacture's instructions;
- (3) set the gauge length at 1";
- (4) place the sample in the flat surface of the jaws according to the manufacture's instructions;
- 35 (5) set the cross head speed at a constant speed of 10"/min;

(6) start the sustained load stress relaxation test and collect data simultaneously, the sustained load stress relaxation test has the following steps:

- a) go to 200% elongation at the constant rate of 10"/min;
- b) hold position for 30 seconds;
- 5 c) go to 0% strain at the constant speed of 10"/min;
- d) hold position for 60 seconds;
- e) go to 50% elongation at the constant speed of 10"/min;
- f) hold position for 10 hours; and
- g) go to 0% strain; and

10 (7) calculate and report properties including initial and final load (i.e., the Final Sustained Load), and % loss. The average result of three samples is reported.

The % loss is the stress relaxation at sustained load at 10 hours and is expressed as  $[(\text{initial load at 50\% elongation of cycle 2} - \text{final load at 50\% elongation of cycle 2 after 10 hours}) / \text{initial load at 50\% elongation of cycle 2}] \times 100$ .

15

#### EXAMPLES

Extrudable and formable elastomeric compositions are prepared by blending varying amount of a styrenic elastomeric copolymer such as Kraton® G1600 series from Shell Chemical Company, Houston, TX, or SEPTON® S4000 or S8000 series from Kuraray America, Inc., New York, NY, a vinylarene resin such as polystyrene PS210 from Nova Chemical, Inc. Monaca, PA, and mineral oil such as Drakeol® available from Pennzoil Co., Penreco Div., Kams City, PA, to form an elastomeric mixture.

20 Examples of the elastomeric composition suitable for use herein are shown in Table 1. The amount of each component is expressed in weight percent of the elastomeric composition. Additives, specifically antioxidants, which are present only in small amounts are not shown in the compositions of TABLE 1. Typically, the elastomeric compositions useful in the present invention comprise about 0.5 wt% of antioxidants.

TABLE 1

30

**Elastomeric Compositions (Weight Percent)**

Sample	1	2	3	4
S-E-EP-S Block Copolymer	55	55	55	55
Septon® S-4033				
Polystyrene PS210	15		10	10



Resin Piccotex® 120		15	5	
Resin Kristalex® 5140				5
Mineral Oil Drakeol®	30	30	30	30

The physical properties of extruded monolayer films of the elastomeric compositions of TABLE 1 are shown in TABLE 2. These properties are determined by the TEST Methods described hereinabove. All physical properties in Table 2 are expressed on an equal basis weight of the film samples. TABLE 2 illustrates that replacing polystyrene with lower molecular weight aromatic hydrocarbon resins provides surprisingly equivalent elastic and stress relaxation properties, even though the total weight percent of the composition constituting the three-dimensional entangled network is reduced.

10

TABLE 2

**Properties of The Extruded Films of The Elastomeric Compositions**

Sample	1	2	3	4
Basis Weight (g/m <sup>2</sup> )	70	70	70	70
Stress at 100% Elongation (g/in)	183	226	182	179
Stress at 200% Elongation (g/in)	267	261	252	266
Stress Relaxation at 200% Elongation (%)	6	11	7	7
Set After A First Cycle to 200% Elongation(%)	1	3	2	1
Final Sustained Load at 50% Elongation (g/in)	86	68	74	82
Stress Relaxation at Sustained Load at 10 hours (%)	27	43	35	28
% Elongation at Break	721	660	737	666

The physical properties of composition 1 disclosed in TABLE 3 are determined as an extruded monolayer elastomeric film, as a co-extruded multilayer film and as a three-dimensional vacuum formed web.

15

A planar coextruded multilayer film is produced and then formed by methods disclosed above into an elastomeric web, generally as shown in the photomicrographs of FIGs. 9-11. The coextruded film comprises three layers as depicted in FIG. 4. The center elastomeric layer comprises styrenic triblock copolymer blended with polystyrene and mineral oil, and optionally aromatic hydrocarbon resins. The elastomeric layer is typically about 0.052 mm (3.2 mils) thick. The skin layers comprise polyolefin materials and each is typically about 0.0038 mm (0.15 mil) thick. The total gauge of the film is approximately 0.09 mm (3.5 mils) with the elastomeric layer

20

being approximately 75-90% of the thickness. A monolayer elastomeric film is also produced by methods generally known in the art to form a film of about 0.072mm (2.8 mils) thick. The films are cut to into proper sample size according to the test methods described hereinabove.

While being difficult to measure accurately, the gauge of the three-dimensional elastomeric web from the first surface to the second surface was on the order of 1 mm, for a draw ratio of approximately 10:1. In an as-formed, unextended configuration the continuous first surface generally formed a regular pattern of 1 mm square fluid-permeable apertures spaced about 1 mm apart on all sides. The secondary apertures were slightly smaller than the primary apertures giving the elastomeric web an open apertured area of approximately 12-16%.

The exemplary elastomeric web of the present invention exhibited reliable elastic performance by repeated and sustained web strains of up to about 400% or more without significant affect on web elasticity or porosity. In general, the web exhibited a higher modulus in the first extension as the skin layers experienced inelastic strain. Thereafter it is believed that microscopic rugosities formed on the interconnecting members in the regions of inelastic skin layer strain, which resulted in a lower and generally constant web modulus.

TABLE 3  
Properties of The Elastomeric Films/Webs

Sample	1a	1b	1c
Basis Weight (g/m <sup>2</sup> )	71	89	88
Stress at 100% Elongation (g/in)	186	293	258
Stress at 200% Elongation (g/in)	271	346	307
Stress Relaxation at 200% Elongation (%)	6	11	13
Set After A First Cycle to 200% Elongation(%)	1	8	10
Final Sustained Load at 50% Elongation (g/in)	87	98	76
Stress Relaxation at Sustained Load at 10 hours (%)	27	33	33
% Elongation at Break	721	667	669

wherein Sample 1a is an extruded monolayer elastomeric film of composition 1; Sample 1b is a coextruded multilayer film having composition 1 as the center layer and polyethylene as the skin layers disposed on the opposed surfaces of the center layer; and sample 1c is a three-dimensional elastomeric web formed according to the methods described hereinabove from the multilayer coextruded film of 1b.

The disclosures of all patents, patent applications (and any patents which issue thereon, as well as any corresponding published foreign patent applications), and publications mentioned throughout this description are hereby incorporated by reference herein. It is expressly not admitted, however, that any of the documents incorporated by reference herein teach or disclose  
5 the present invention.

While particular embodiments of the present invention have been illustrated and described, it would be obvious to those skilled in the art that various other changes and modifications can be made without departing from the spirit and scope of the invention. It is therefore intended to cover in the appended claims all such changes and modifications that are  
10 within the scope of this invention.

## WHAT IS CLAIMED IS:

1. A low stress relaxation elastomeric material suitable for being formed into a porous, macroscopically-expanded, three-dimensional elastomeric web, said elastomeric material comprising:
  - a) from 20 to 80 wt% of an elastomeric block copolymer, said copolymer comprising from 10% to 80% by weight of at least one hard block and from 20% to 90% by weight of at least two soft block
  - b) from 3 to 60 wt% of at least one vinylarene resin; and
  - c) from 5 to 60 wt% of a processing oil;wherein the elastomeric material has a stress relaxation of less than 20% at 200% elongation at room temperature and a stress relaxation of less than 45% after 10 hours at 100°F and 50% elongation.
2. A material according to claim 1 wherein the elastomeric block copolymer is selected from the group consisting of A-B-A triblock copolymers, A-B-A-B tetrablock copolymers, A-B-A-B-A pentablock copolymers, and mixtures thereof, wherein A is a hard block derived from vinylarene monomers or a mixture of vinylarene and olefinic monomers, and B is a soft block derived from olefinic monomers.
3. A material according to any one of the preceding claims wherein the vinylarene monomers are selected from the group consisting of styrene,  $\alpha$ -methyl styrene, other styrene derivatives, and mixtures thereof, and the olefinic monomers are selected from the group consisting of ethylene, propylene, butylene, isoprene, butadiene, and mixtures thereof.
4. A material according to any one of the preceding claims wherein number-average molecular weight of the hard block ranges from 1,000 to 200,000, preferably from 2,000 to 100,000, and more preferably from 5,000 to 60,000 and number-average molecular weight of the soft block ranges from 1,000 to 300,000, preferably from 10,000 to 200,000, and more preferably from 20,000 to 100,000.
5. A material according to any one of the preceding claims wherein the vinylarene resin is derived from monomers selected from the group consisting of styrene,  $\alpha$ -methyl styrene, other styrene derivatives, vinyl toluene, and mixtures thereof, the vinylarene resin has a number-average molecular weight in the range from 600 to 200,000, preferably from 5,000 to

150,000, and more preferably from 10,000 to 100,000 and has a glass transition temperature range from 58°C to 180°C, preferably from 70°C to 150°C, and more preferably from 90°C to 130°C.

6. A material according to any one of the preceding claims wherein the vinylarene resin is a mixture of a polystyrene and low molecular weight aromatic hydrocarbon resin at a concentration ratio of polystyrene to low molecular weight aromatic hydrocarbon resin in the range of 1:10 to 10:1, preferably from 1:4 to 4:1, the polystyrene has a number-average molecular weight from 10,000 to 100,000, and preferably from 40,000 to 60,000, and said aromatic hydrocarbon resin has a number-average molecular weight of 600 to 10,000, and preferably from 600 to 4,000.
7. A material according to any one of the preceding claims wherein the block copolymer is a styrene-olefin-styrene triblock copolymer selected from the group consisting of styrene-butadiene-styrene (S-B-S), styrene-ethylene/butylene-styrene (S-EB-S), styrene-ethylene/propylene-styrene (S-EP-S), styrene-isoprene-styrene (S-I-S), hydrogenated polystyrene-isoprene/butadiene-styrene (S-IB-S) and mixtures thereof, the vinylarene resin is polystyrene, and the processing oil is mineral oil.
8. A low stress relaxation elastomeric film suitable for being formed into a porous, macroscopically-expanded, three-dimensional elastomeric web, said elastomeric film comprising an elastomeric layer having opposed first and second surfaces and at least one substantially less elastomeric skin layer substantially continuously joined to said first surface of the elastomeric layer, said elastomeric layer having a composition according to any one of the preceding claims.
9. A film according to claim 8 wherein the elastomeric layer comprises from 20% to 95% of the total thickness of the material, and the skin layer comprises from 1% to 40% of the total thickness of the material.
10. A film according to claims 8 or 9 wherein the skin layer comprises a thermoplastic polymer selected from the group consisting of polyolefins, ethylene copolymers, polystyrenes, poly( $\alpha$ -methyl styrenes), styrenic random block copolymers, polyphenylene oxides, and mixtures thereof.

11. An article to be worn adjacent to a person's body, said article comprising an elasticized portion comprising a low stress relaxation elastomeric material according to any one of the preceding claims.
12. An article according to claim 11 wherein said elasticized portion is a bandage, a wrap, an absorbent article or a wound dressing.
13. An article according to claims 11 or 12 wherein said article is an absorbent article, and said elasticized portion of the absorbent article is a waist band, a side panel, a cuff, a topsheet, or a backsheet.

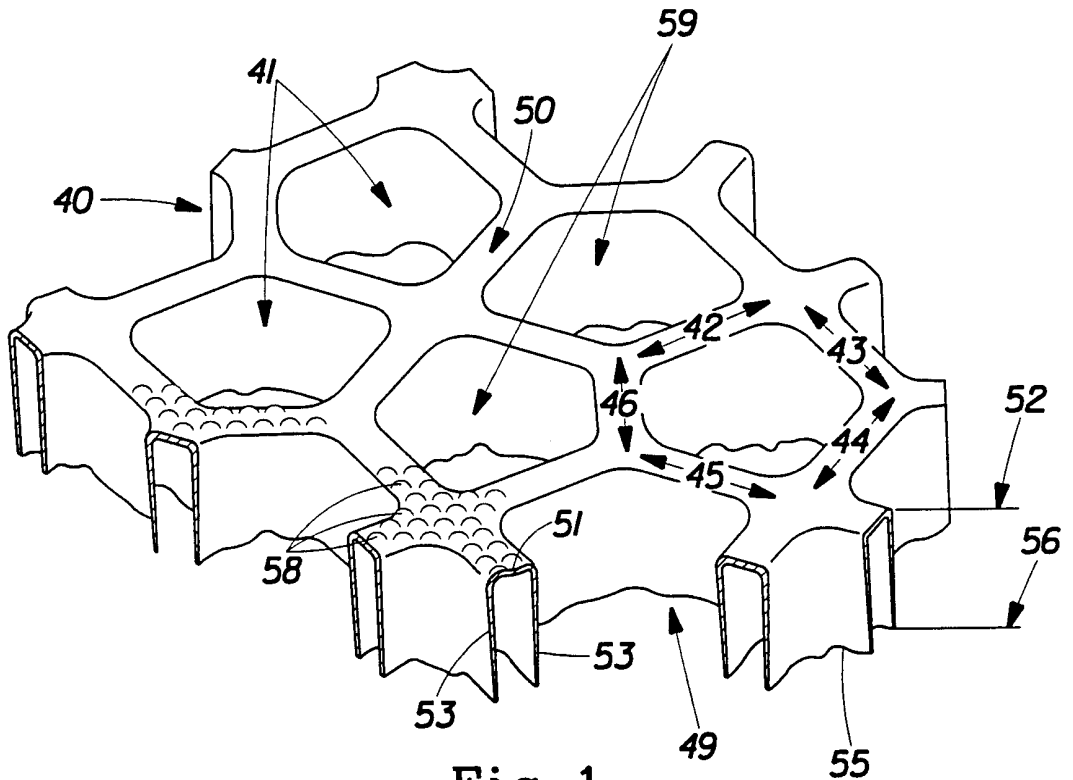

Fig. 1  
(PRIOR ART)

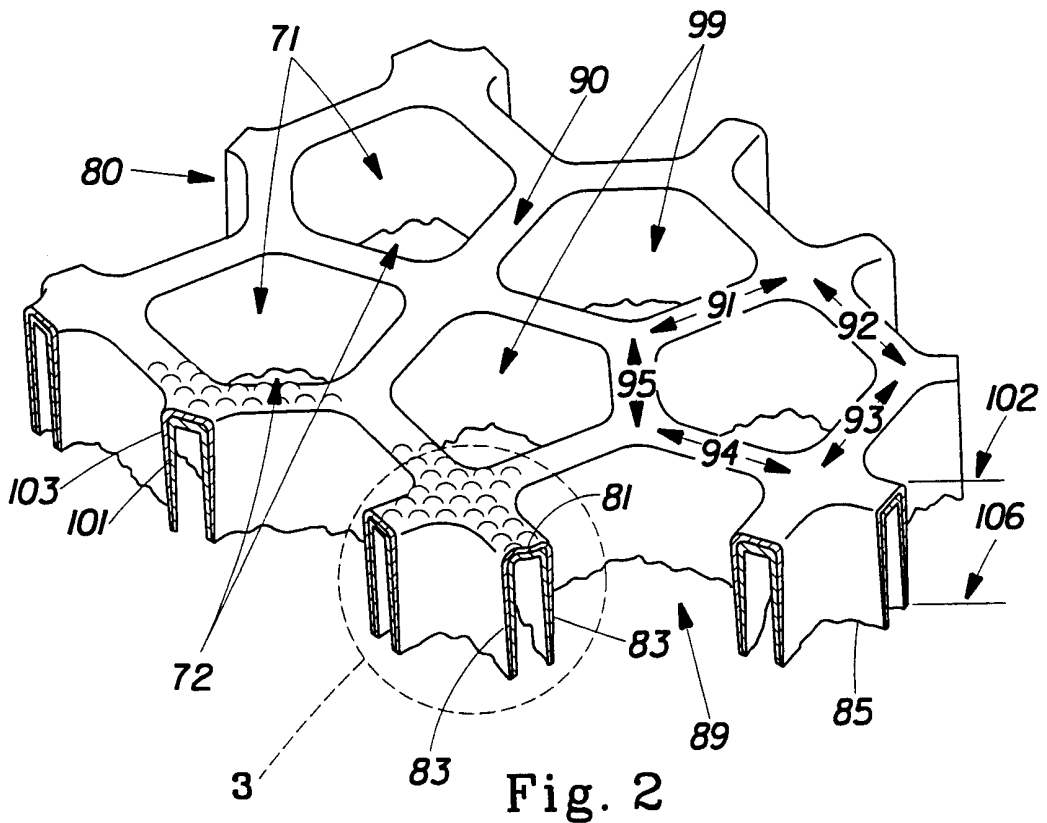

Fig. 2

2/12

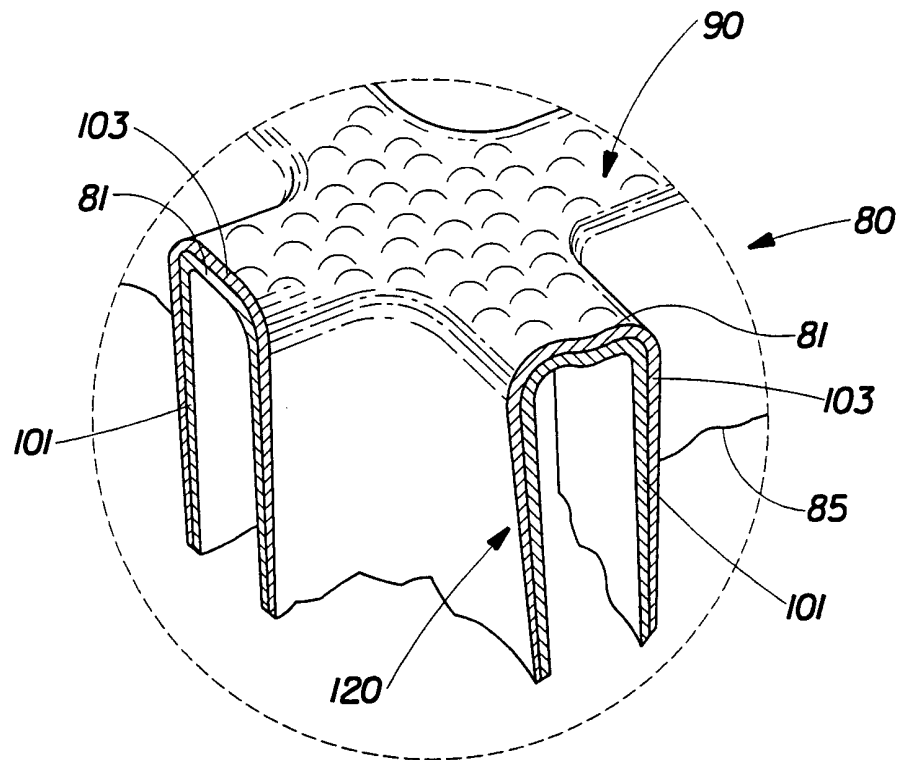

Fig. 3

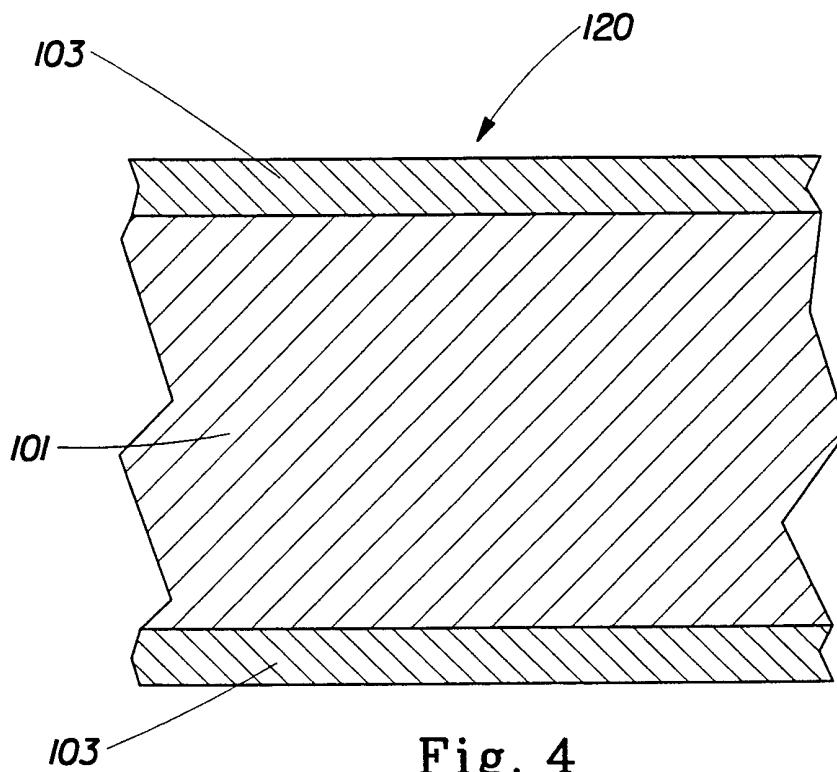

Fig. 4



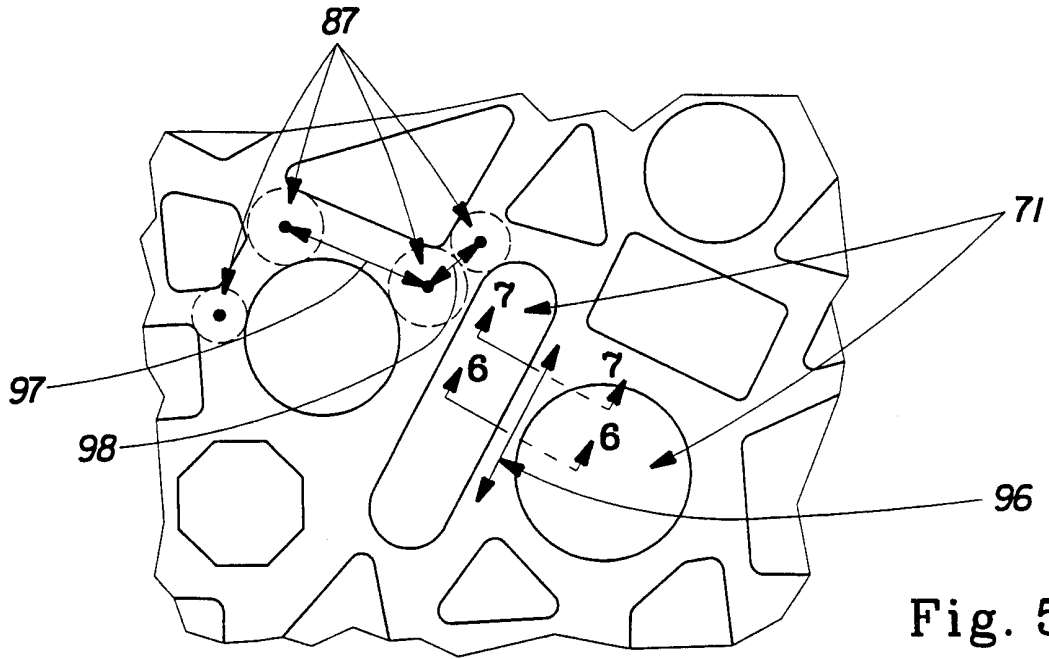

Fig. 5

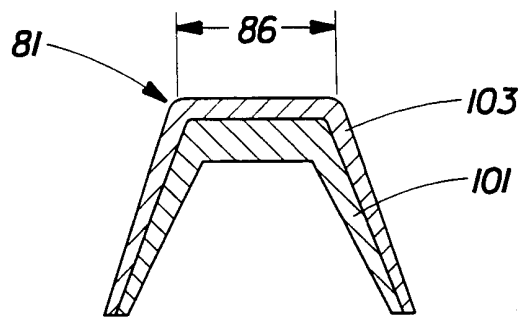

Fig. 6

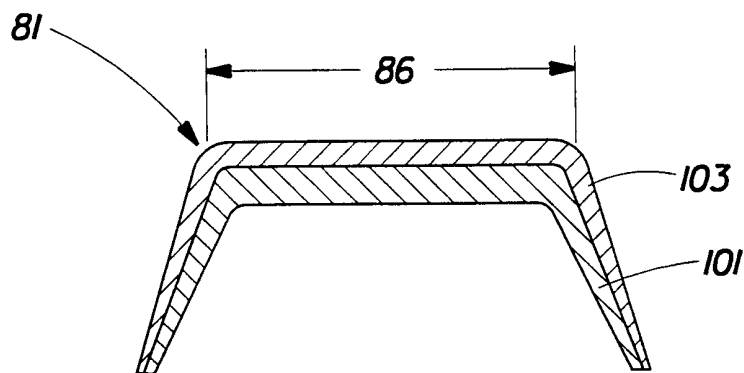
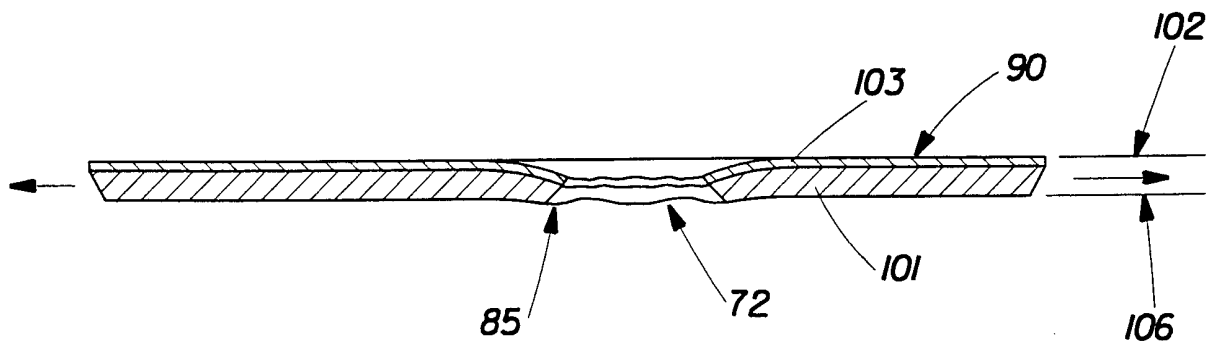
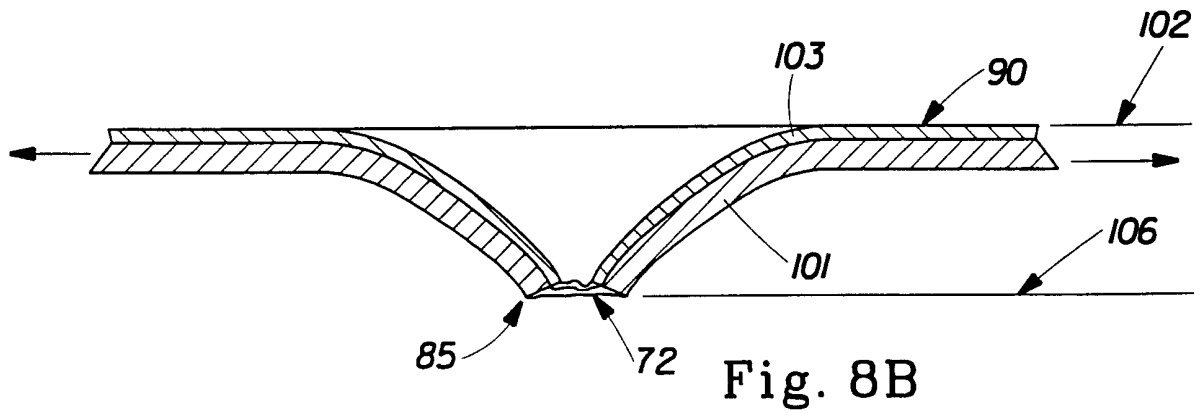
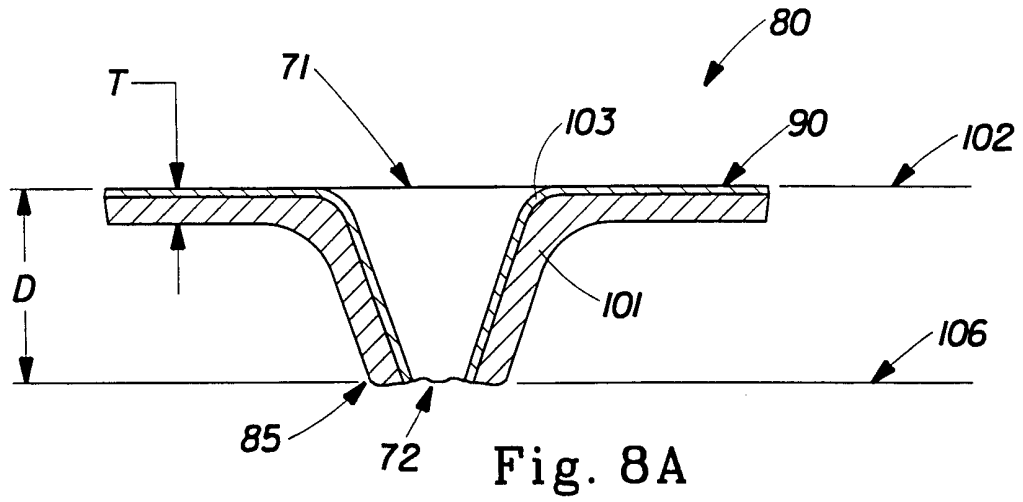

Fig. 7

4/12



5/12

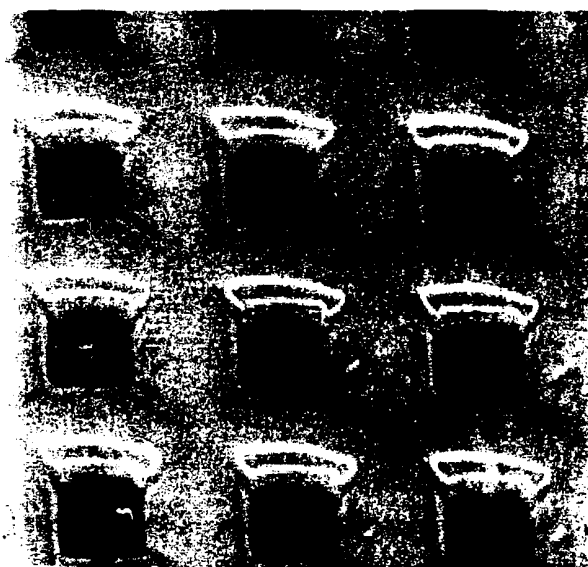

Fig. 9

6/12



Fig. 10

7/12

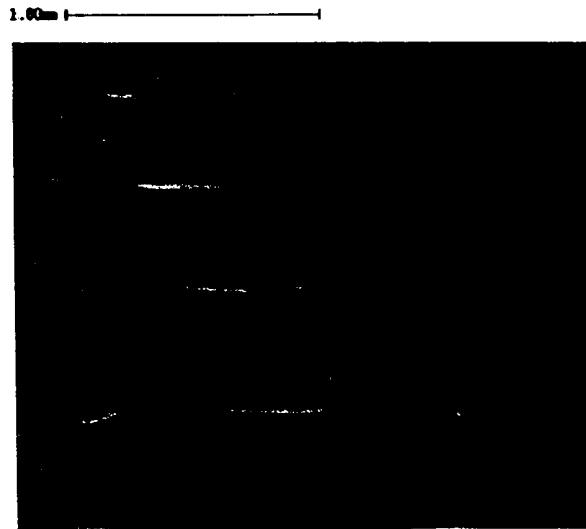

Fig. 11

8/12

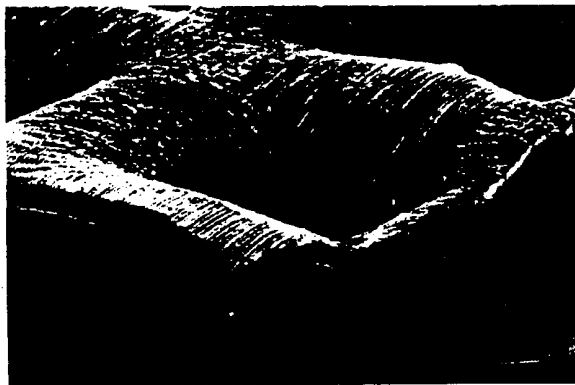
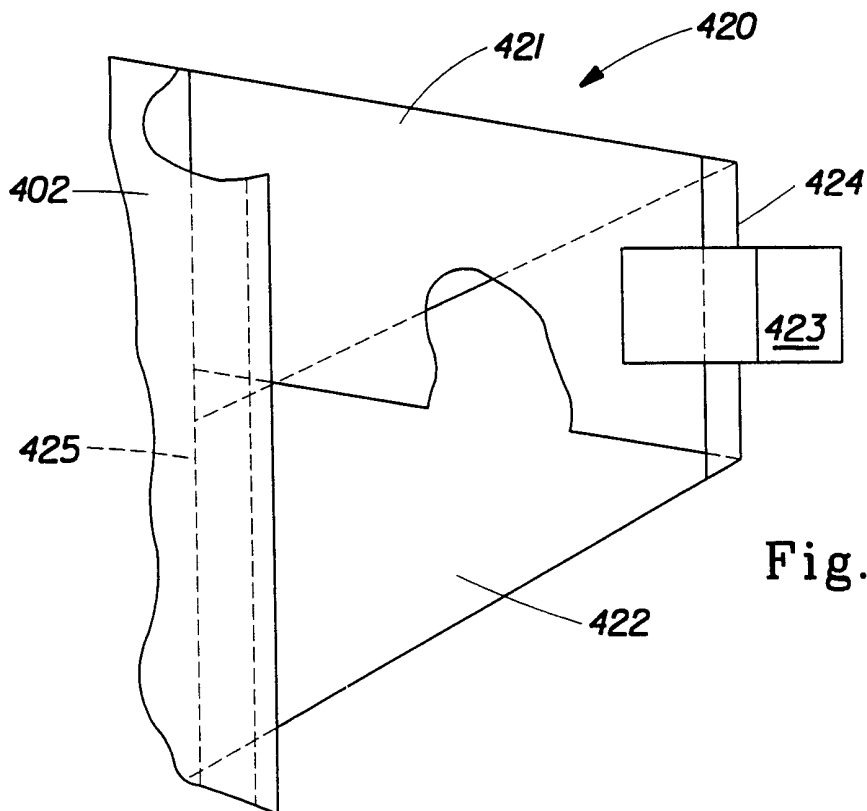
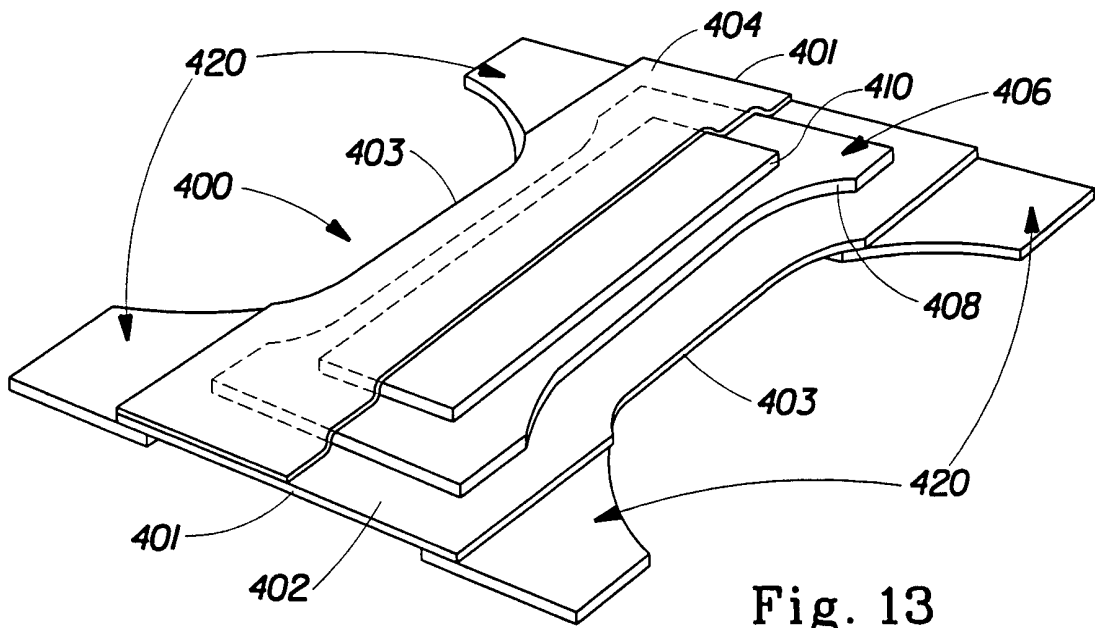

Fig. 12



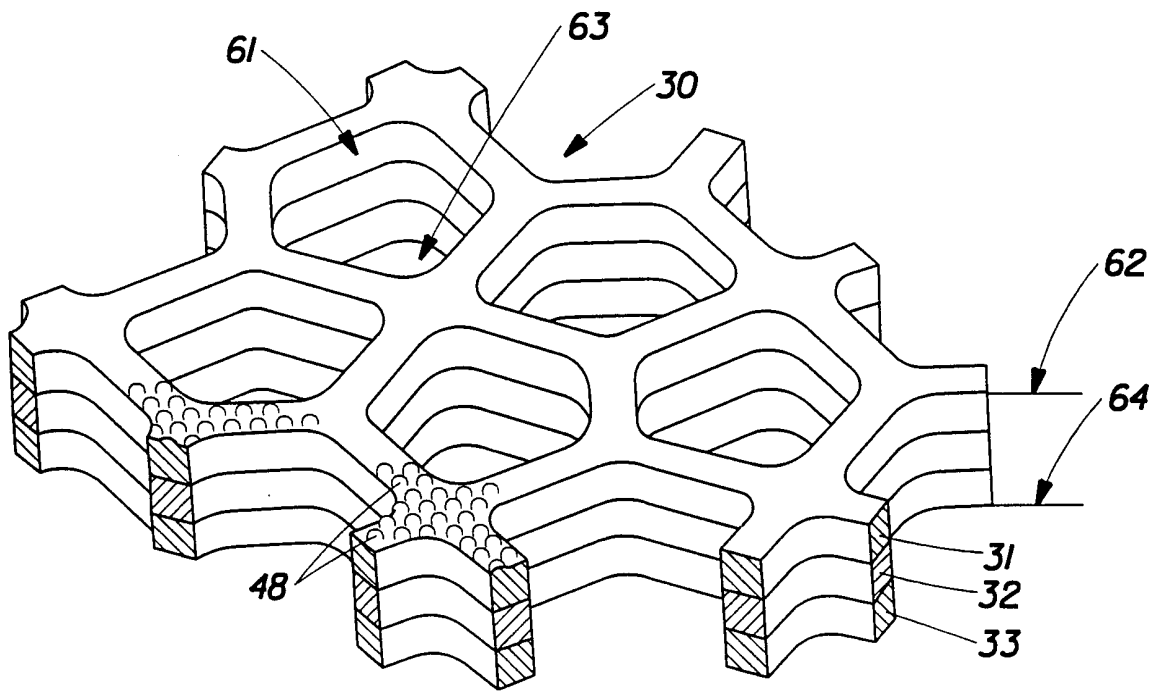

Fig. 15



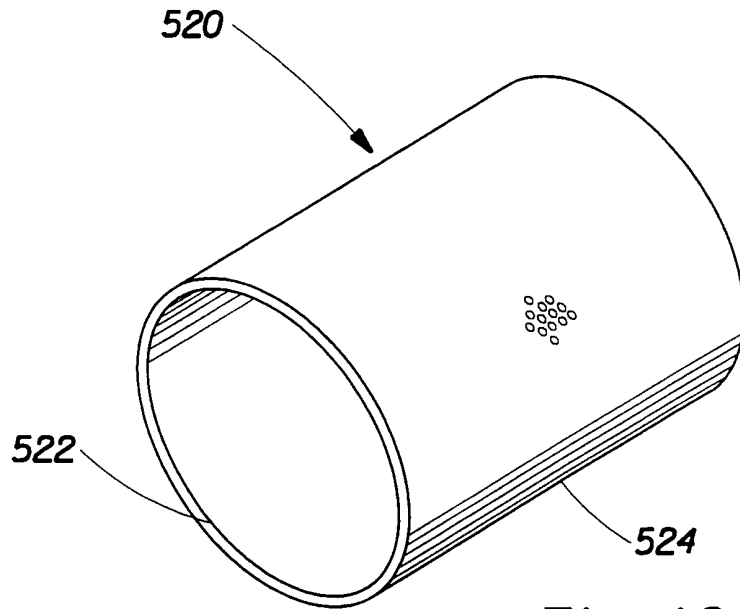

Fig. 16

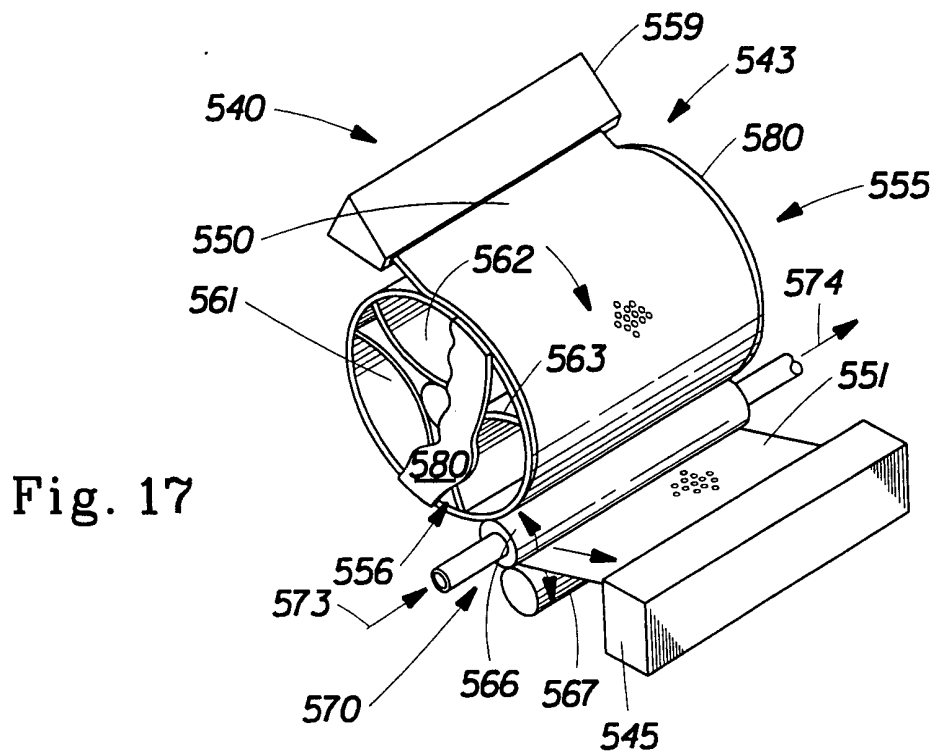

Fig. 17

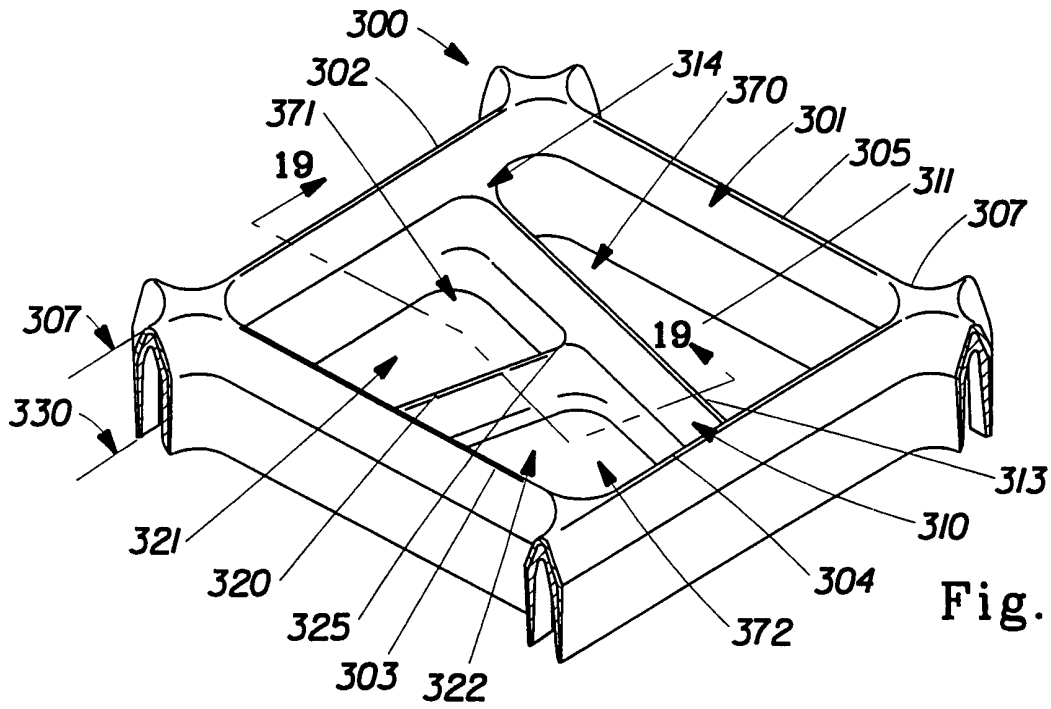

Fig. 18

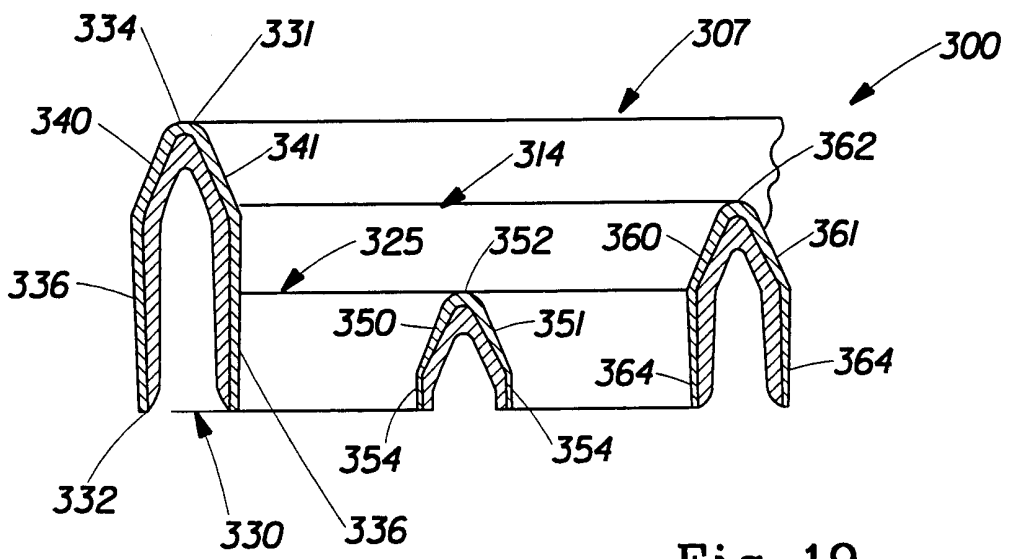

Fig. 19

# INTERNATIONAL SEARCH REPORT

International Application No  
PCT/US 00/24924

**A. CLASSIFICATION OF SUBJECT MATTER**  
IPC 7 C08L53/02 A61F13/15 B32B27/32

According to International Patent Classification (IPC) or to both national classification and IPC

**B. FIELDS SEARCHED**

Minimum documentation searched (classification system followed by classification symbols)  
IPC 7 C08L C09J C09D B32B A61L A61F B29D

Documentation searched other than minimum documentation to the extent that such documents are included in the fields searched

Electronic data base consulted during the international search (name of data base and, where practical, search terms used)

EPO-Internal, WPI Data, PAJ

**C. DOCUMENTS CONSIDERED TO BE RELEVANT**

Category °	Citation of document, with indication, where appropriate, of the relevant passages	Relevant to claim No.
X	US 5 503 919 A (LITCHHOLT JOHN J ET AL) 2 April 1996 (1996-04-02) * claims 1-25 ; column 7, line 39-44 ; column 6, line 35-66 * abstract; table I ---	1-13
X	EP 0 673 970 A (SHELL INT RESEARCH) 27 September 1995 (1995-09-27) * abstract ; page 3, line 12-17 ; page 3, line 34-57 ; page 4, line 7-10 ; page 4, line 42-44 ; page 3, line 29-31 * page 5, line 4-10; claims 1-12 ---	1-5,7-10
X	US 4 704 110 A (RAYKOVITZ GARY F ET AL) 3 November 1987 (1987-11-03) * claim 12 ; claims 1-15 ; column 3, line 25-26 * column 2, line 1-16 ---	1-13
	-/--	



Further documents are listed in the continuation of box C.



Patent family members are listed in annex.

° Special categories of cited documents :

- \*A\* document defining the general state of the art which is not considered to be of particular relevance
- \*E\* earlier document but published on or after the international filing date
- \*L\* document which may throw doubts on priority claim(s) or which is cited to establish the publication date of another citation or other special reason (as specified)
- \*O\* document referring to an oral disclosure, use, exhibition or other means
- \*P\* document published prior to the international filing date but later than the priority date claimed

- \*T\* later document published after the international filing date or priority date and not in conflict with the application but cited to understand the principle or theory underlying the invention
- \*X\* document of particular relevance; the claimed invention cannot be considered novel or cannot be considered to involve an inventive step when the document is taken alone
- \*Y\* document of particular relevance; the claimed invention cannot be considered to involve an inventive step when the document is combined with one or more other such documents, such combination being obvious to a person skilled in the art.
- \* & \* document member of the same patent family

Date of the actual completion of the international search

2 January 2001

Date of mailing of the international search report

11/01/2001

Name and mailing address of the ISA

European Patent Office, P.B. 5818 Patentlaan 2  
NL - 2280 HV Rijswijk  
Tel. (+31-70) 340-2040, Tx. 31 651 epo nl,  
Fax: (+31-70) 340-3016

Authorized officer

Hammond, A

## INTERNATIONAL SEARCH REPORT

International Application No

PCT/US 00/24924

C.(Continuation) DOCUMENTS CONSIDERED TO BE RELEVANT		
Category *	Citation of document, with indication, where appropriate, of the relevant passages	Relevant to claim No.
X	WO 95 03447 A (SHELL INT RESEARCH) 2 February 1995 (1995-02-02) * claims 1,5,7,8,14,16 ; page 1, line 1-6* page 6, line 29-34 ----	1-5,7
X	US 4 578 302 A (SCHMIDT JR ROBERT C ET AL) 25 March 1986 (1986-03-25) * claims 1-20 * column 2, line 61,62 ----	1-10
X	EP 0 574 591 A (SUMITOMO CHEMICAL CO ;TOYODA GOSEI KK (JP)) 22 December 1993 (1993-12-22) page 3, line 29-47; claims 1,6,7 ----	1-3,5,7
X	WO 95 26380 A (HARRISON JACQUES ;OUHADI TRAZOLLAH (BE); ADVANCED ELASTOMER SYSTEMS) 5 October 1995 (1995-10-05) * page 4, line 25-page 5, line 6 ; page 7, line 32 - page 8, line 2 ; page 10, line 21 ; page 10, line 29-33 ; page 9, line 14-26 ; page 10, line 10-13 ; page 15, line 9 - page 18, line 7 ; examples * page 1, line 8-10; claims 1-18 ----	1-5,7-13
X	EP 0 518 444 A (SHELL INT RESEARCH) 16 December 1992 (1992-12-16) * claims 1-7,11,12 * page 3, line 13 -page 4, line 27; tables I-IIIJ -----	1-5,7, 11-13

## INTERNATIONAL SEARCH REPORT

Information on patent family members

International Application No

PCT/US 00/24924

Patent document cited in search report	Publication date	Patent family member(s)	Publication date
US 5503919 A	02-04-1996	US 5342858 A	30-08-1994
		AT 169952 T	15-09-1998
		AU 7313194 A	24-01-1995
		CA 2164812 A	12-01-1995
		DE 69412621 D	24-09-1998
		DE 69412621 T	25-02-1999
		EP 0706547 A	17-04-1996
		ES 2119217 T	01-10-1998
		JP 8512076 T	17-12-1996
		WO 9501408 A	12-01-1995
		EP 0673970 A	27-09-1995
BR 9501184 A	30-04-1996		
CA 2145353 A	26-09-1995		
CN 1126223 A	10-07-1996		
DE 69509958 D	08-07-1999		
DE 69509958 T	14-10-1999		
FI 951384 A	26-09-1995		
JP 7258512 A	09-10-1995		
NO 951114 A	26-09-1995		
US 5540983 A	30-07-1996		
US 4704110 A	03-11-1987		
		AU 7459587 A	07-01-1988
		CA 1314177 A	09-03-1993
		EP 0249979 A	23-12-1987
		JP 63003073 A	08-01-1988
		ZA 8704394 A	30-03-1988
WO 9503447 A	02-02-1995	AT 165634 T	15-05-1998
		AU 686655 B	12-02-1998
		AU 7495094 A	20-02-1995
		BR 9407081 A	13-08-1996
		CA 2167686 A	02-02-1995
		CN 1129022 A	14-08-1996
		DE 69409956 D	04-06-1998
		DE 69409956 T	03-09-1998
		DK 710305 T	07-10-1998
		EP 0710305 A	08-05-1996
		ES 2115250 T	16-06-1998
		FI 960273 A	19-01-1996
		JP 9500692 T	21-01-1997
		NO 960238 A	19-03-1996
		RU 2138398 C	27-09-1999
		US 4578302 A	25-03-1986
EP 0574591 A	22-12-1993	CA 2104775 A	09-07-1993
		JP 5301998 A	16-11-1993
		WO 9314160 A	22-07-1993
		US 5597860 A	28-01-1997
WO 9526380 A	05-10-1995	DE 69500810 D	06-11-1997
		DE 69500810 T	09-04-1998
		EP 0753027 A	15-01-1997
		ES 2107315 T	16-11-1997
		JP 10501824 T	17-02-1998
		US 5843577 A	01-12-1998

# INTERNATIONAL SEARCH REPORT

...ormation on patent family members

Internat Application No

PCT/US 00/24924

Patent document cited in search report	Publication date	Patent family member(s)	Publication date
EP 0518444 A	16-12-1992	BR 9202225 A	16-03-1993
		CN 1068128 A	20-01-1993
		JP 5230228 A	07-09-1993
-----			