

H. M. SKINNER.

Cultivator.

No. 108,398.

Patented Oct. 18, 1870.

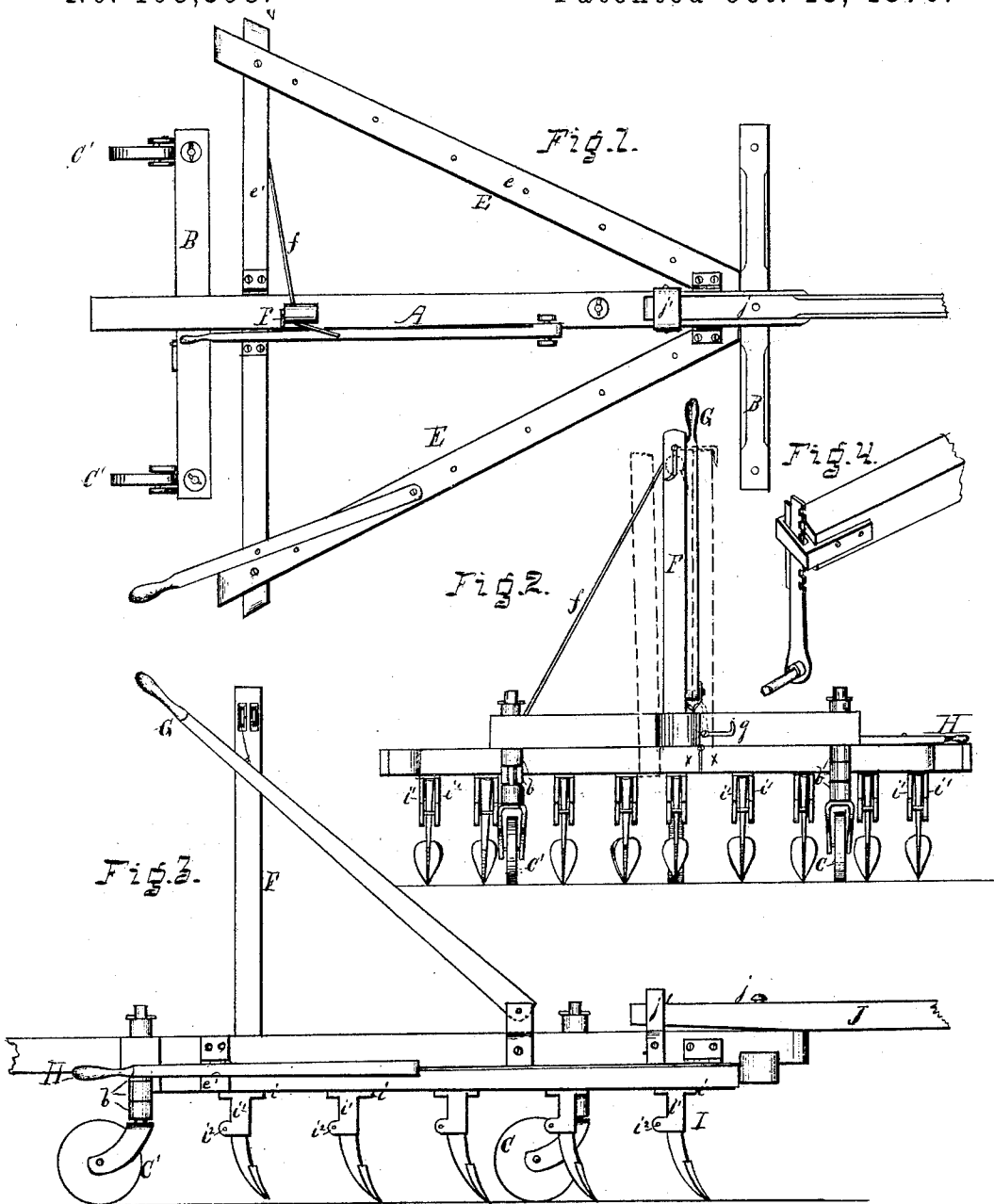

Witnesses:
E. H. Pearson
J. J. Hayes

Inventor:
H. M. Skinner by
A. W. Beadle atty

UNITED STATES PATENT OFFICE.

HENRY M. SKINNER, OF ROCKFORD, ILLINOIS.

IMPROVEMENT IN CULTIVATORS.

Specification forming part of Letters Patent No. 108,398, dated October 18, 1870; antedated October 12, 1870.

To all whom it may concern:

Be it known that I, H. M. SKINNER, of Rockford, in the county of Winnebago and State of Illinois, have invented a new and useful Improvement in Cultivators; and I do hereby declare that the following is a full and exact description of the same, reference being had to the accompanying drawings, and to the letters of reference marked thereon.

This invention relates to that class of cultivators which ordinarily employ a single rigid frame in which the teeth are inserted; and it consists, mainly, in hinging the side leaves or wings to a center beam, and in the employment of suitable lifting devices, by means of which the wings are raised and lowered, as may be desired.

In the drawings, Figure 1 represents a plan view of my improved cultivator; Fig. 2, an end elevation; Fig. 3, a side elevation; and Fig. 4, a perspective view of the standard for holding the supporting-wheels.

To enable others skilled in the art to make and use my invention, I will now proceed to fully describe its construction and operation.

A represents a longitudinal center beam, which is provided with the transverse end beams, B B.

C C' C' represent supporting-wheels, the front one of which should be a caster-wheel. The rear wheels may be caster-wheels or not, as preferred. When the machine is used for cultivating small plants, the front caster-wheel is removed from the center beam and placed at one end of the transverse beam B, an additional wheel, of course, being placed at the other end; but when used for harrowing and such purposes the front caster-wheel is attached to the center beam, as shown. The caster-wheels are adjusted vertically by means of the washers *b b*, as shown. When caster-wheels are not used at the rear of the machine, I employ the standard D, which is secured to the end of the transverse beam by means of a slotted iron, *d*, through which it passes, as shown. This iron is securely bolted to the beam. The standard is notched, as shown, and engages thereby with a pin in the slot of the iron *d*, it being secured in place by means of a wedge, *d'*. It may be adjusted vertically by removing the wedge and disengaging its

notched surface from the pin, when it will be free to move in either direction.

E E represent the side leaves, which consist of the diverging beams *e e* and transverse beams *e' e'*. These leaves are hinged to the center beam in any suitable manner. They are preferably so connected, however, to the center beam that the beams *e' e'* swing beneath the latter, their adjacent ends bearing against one another when the leaves are lowered, as shown at *x x* in Fig. 2. By this construction the downward motion of the leaves is limited, and it becomes impossible for them to become doubled up by swinging down too far. Other arrangements, of course, may be made for limiting the downward motion of the leaves, but this is believed to be the best. It will be observed that one of the beams *e'* is longer than the other, by means of which I am enabled to place a tooth beneath the center beam.

F represents a standard, which rises perpendicularly from the center beam, and is provided near its top with pulleys. *f* represents a cord or chain, one end of which is attached to one of the leaves, as shown, and the other, after passing over one of the pulleys in standard F, is attached to the lever G, as shown. This lever is pivoted upon the center beam, and when depressed is held in place by means of the hook *g*, or other suitable fastening.

H represents a handle, attached also to one of the leaves, by means of which it may be lifted, which is secured in place, when raised, by a hook or other suitable fastening at the top of the standard.

I I represent sockets for the teeth. They consist of an iron provided with the head *i* and sides *i'*. This head is securely bolted to the under side of the beam, as shown. Between the sides *i'* the shank of the tooth is secured by a bolt or pin, as shown, by which arrangement it is permitted to swing freely in either direction. To limit its backward movement, however, I place an additional pin, which should be made of wood, in the projections *i''* of the sides *i'*. By this construction the teeth are permitted to swing freely forward when the team is backing, but are forced immediately into place when the forward movement is begun. If a serious obstruction

is met with, the wooden pin gives way and permits the tooth to swing back, and thus pass over it. When it is desired to cultivate but a portion of the ground, any desired number of teeth may be thrown up out of the way, or they may be removed from their sockets, if desired. By changing the position of the socket-irons on the beam, the teeth may be set at any desired angles.

J represents the pole, which is secured at *j*, as shown. Its downward motion is limited by the stop *j'*. Its rear end is cut away upon its lower side to permit it to have the necessary play. It may be used with the machine or not, as desired.

The advantages of this mode of construction are as follows: The machine can be readily transported from place to place by simply raising the leaves, when it will run entirely upon the supporting-wheels. The teeth are readily removed or thrown up out of the way,

and again replaced when it is desired to change the cultivator for the different purposes for which it is designed.

The whole machine is simple in construction and is not liable to get out of order.

Having thus fully described my invention, what I claim as new, and desire to secure by Letters Patent, is—

The machine described, having the longitudinal center beam, A, transverse end beams, B B, supporting-wheels C C', hinged side leaves, E E, and teeth I, when combined and arranged as described, for the purpose set forth.

This specification signed and witnessed this 11th day of October, 1869.

HENRY M. SKINNER.

Witnesses:

G. W. FORD,
WILLIAM WELLINGTON.