

(No Model.)

E. F. TRENT.  
FISHING REEL.

No. 313,695.

Patented Mar. 10, 1885.

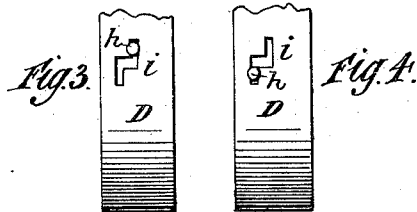
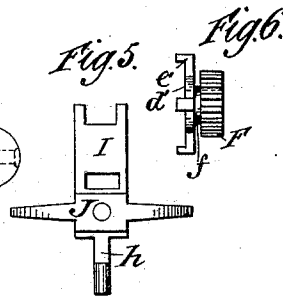
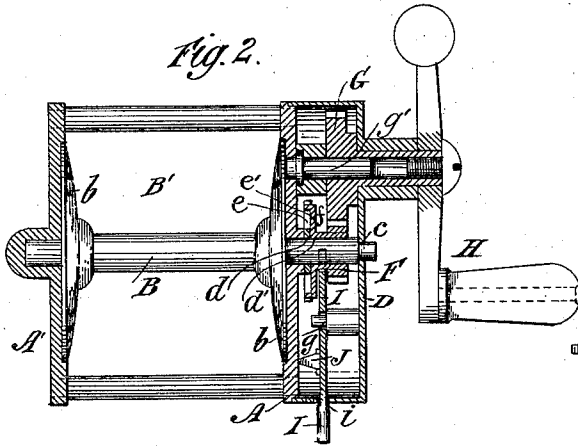
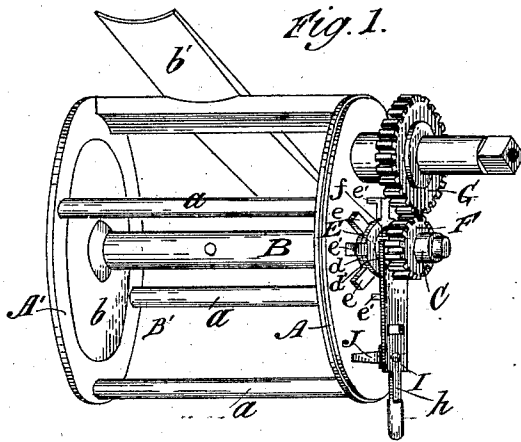

Witnesses  
J. H. Lane  
Daniel Foriscoll

Inventor  
Eugene F. Trent  
by his attorneys  
J. Gifford & Brown

# UNITED STATES PATENT OFFICE.

EUGENE F. TRENT, OF JERSEY CITY, NEW JERSEY.

## FISHING-REEL.

SPECIFICATION forming part of Letters Patent No. 313,695, dated March 10, 1885.

Application filed July 24, 1884. (No model.)

*To all whom it may concern:*

Be it known that I, EUGENE F. TRENT, of Jersey City, in the county of Hudson and State of New Jersey, have invented a certain new and useful Improvement in Reels, of which the following is a specification.

My improvement relates to reels for fishing-lines; and it consists in a novel arrangement of the mechanism for winding and unwinding a line thereon, whereby the bobbin upon which the line is wound may be thrown out of connection with the winding mechanism at will, so as to permit the bobbin to rotate freely when it is desired to unwind the line.

Heretofore this class of reels have been so constructed that when the line was being unwound from the bobbin the winding mechanism was caused to operate very rapidly in a reverse direction from that employed in winding, and the gear-wheels thereof became on such account quickly worn and loose, causing rattling and disagreeable noise.

To obviate this unnecessary wear and tear and to produce a reel that shall be practically silent in its operation is the object of my improvement.

In the accompanying drawings, Figure 1 is a perspective view of a reel embodying my improvement with the end cap removed. Fig. 2 is a longitudinal section of my improvement; and Figs. 3, 4, 5, and 6 are details thereof.

Similar letters of reference designate corresponding parts in all the figures.

A A' are the end plates or disks of the reel, and they are secured together by binding-posts *a* in the usual manner. Said disks are recessed upon their inner surfaces to receive the flanges *b* of a bobbin, B', which said flanges are rigidly secured to a spindle, B, the outwardly-projecting ends of which are journaled in suitable bearings in the plates or disks A A'. When in use a fish-line is to be wound on said bobbin. The reel is adapted to be secured to a fishing-pole by means of a plate, *b'*, rigidly secured to one of the binding-posts. The spindle B has an outwardly-extending portion, C, passing beyond the plate or disk A. Near its outer end said portion C is shouldered to fit into a hole, *c*, in the cap D. At the end of said portion C nearer the disk I have shown arranged one part, *d*, of the clutching device E. Said

part *d* is rigidly secured to the said portion C and rotates therewith. It is provided, as shown, with arms *e*, extending at about right angles to the axis of the spindle. Said arms *e* are adapted to be engaged with arms *e'* on the other part, *d'*, of the clutch E, as shown more clearly in Fig. 1. The outward ends of the arms *e'* of said part *d'* are shown as bent forward, so as to engage more readily with the arms *e* of the part *d*. The part *d'* has upon it a hollow shank or hub, *f*, adapted to fit loosely about the portion C of the spindle in such manner that the portion C may turn freely therein, and being provided with a socket adapted to receive a stud, *g'*, which is rigidly secured to the plate A. Fitted tightly about said shank I have shown a gear-wheel, F. Said gear-wheel F meshes with a gear-wheel, G, having bearings in the cap D. Motion is conveyed to the gear-wheel G by means of a crank, H.

I is a lever fulcrumed upon a pin, *g*, extending from the inner face of the cap D. The said lever has a slotted connection with said pin which admits of a slight lateral motion of said lever. A shoulder on said pin prevents the movement of said lever in one direction. The inwardly-extending end of said lever is preferably bifurcated, said bifurcated end being adapted to fit about the shank *f* of the part *d'* of the clutch E between the gear-wheel F and the arms *e'*. The outwardly-extending end *h* of the said lever is adapted to pass through a slot, *i*, in the rim of the cap D. Said slot is preferably step-shaped, as shown more clearly in Fig. 3. It constitutes a catch for the lever I. Secured to said lever by any suitable means is a spring, J, the ends of which, when in position, are adapted to bear upon the face of the plate or disk A.

When it is desired to unwind a line from the bobbin, the end *h* of the lever I is moved into the position shown in Fig. 4, in which position it is held by the action of the spring J. This operation serves to raise the bifurcated end of said lever, and thereby to lift the part *d'* of the clutch out of engagement with the part *d*. The part *d*, together with the bobbin and spindle, may then rotate freely, the other parts of the mechanism remaining quiescent. When, however, it is desired to rewind the line, the end *h* of the lever is moved

into the position shown in Fig. 3, by which means the clutch-pieces *d* and *d'* are again brought into connection, when, by turning the crank H, the bobbin may be rotated to rewind the line.

It will be observed that the gear-wheels F and G are never out of gear, the movement of the lever I being sufficient only to cause a disengagement of the clutch-pieces but not of the gear-wheels.

The different parts may be made of brass or other suitable metal.

I do not limit myself to the particular form of clutching device described, as the same may obviously be varied; nor do I limit myself to a lever having the bifurcated end, as said lever may have a positive connection with the clutch-piece.

What I claim as my invention, and desire to secure by Letters Patent, is—

1. In a fishing-reel, the combination of a rotary bobbin, a clutch one portion of which is affixed to said bobbin or an appurtenance thereof, and the other to a gear-wheel, another gear-wheel for imparting motion to the first-named gear-wheel, a lever for engaging and disengaging said clutch, and a catch for retaining said lever in different positions, substantially as specified.

2. In a fishing-reel, the combination of a rotary bobbin, a shaft on said bobbin, a clutch having one portion fitting loosely about said

shaft and another portion affixed thereto, a gear-wheel rigidly affixed to said first-named portion and adjustable into different positions on said shaft, another gear-wheel engaging with said adjustable gear-wheel for imparting motion thereto, and a lever for engaging and disengaging the clutch, substantially as specified.

3. In a fishing-reel, the combination of a rotary bobbin, a clutch, gear-wheels for imparting motion to said clutch, a lever for engaging and disengaging the clutch, a catch for retaining said lever in different positions, a spring acting in conjunction with said catch, and a pin for limiting the movement of the lever in one direction, substantially as specified.

4. In a fishing-reel, the combination of a bobbin, B', having the spindle B, with the outwardly-extending portion C, the clutch E, composed of the portions *d d'*, provided with arms *e e'*, the adjustable gear-wheel F, the gear-wheel G, the crank H, and the lever I, substantially as specified.

5. In a reel, the combination of a bobbin, the clutch E, the lever I, having the outwardly-extending end *h*, the spring J, and the cap D, having the slot *i*, substantially as specified.

E. F. TRENT.

Witnesses:

T. J. KEANE,  
E. T. ROCHE.