

ORGANISATION AFRICAINE DE LA PROPRIETE INTELLECTUELLE
(O.A.P.I.)



19

11

N°

13023

51

Inter. Cl. 7

E21B 4/02

BREVET D'INVENTION

21 Numéro de dépôt : 1200500222

22 Date de dépôt : 05.08.2005

30 Priorité(s) : US
22.11.2004 N° 10/994,799

24 Délivré le : 30.12.2005

45 Publié le : 10.11.2006

73 Titulaire(s) :

ANADARKO PETROLEUM CORPORATION
1201 Lake Robbins Drive
THE WOODLANDS, Texas 77380 (US)

72 Inventeur(s) :

1- MILLHEIM, Keith
62 Thistle Wind Court
THE WOODLANDS, Texas (US)
2- MAIDLA, Eric E. (US)
3- KING, Charles H. (US)

74 Mandataire : Cabinet EKANI CONSEILS
B.P. 5852 YAOUNDE (CM)

54 Titre : System and method of installing and maintaining an offshore exploration and production system having an adjustable buoyancy chamber.

57 Abrégé :

A system and method of establishing an offshore exploration and production system is disclosed, in which a well casing is disposed in communication with an adjustable buoyancy chamber and a well hole bored into the floor of a body of water. A lower connecting member joins the well casing and the chamber, and an upper connecting member joins the adjustable buoyancy chamber and a well terminal member. The chamber's adjustable buoyancy enables an operator to vary the height or depth of the well terminal member, and to vary the vertical tension imparted to drilling and production strings throughout exploration and production operations. Also disclosed is a system and method of adjusting the height or depth of a wellhead while associated vertical and lateral forces remain approximately constant. A variety of well isolation members, lateral stabilizers and anchoring means, as well as several methods of practicing the invention, are also disclosed.

**SYSTEM AND METHOD OF INSTALLING AND MAINTAINING AN
OFFSHORE EXPLORATION AND PRODUCTION SYSTEM HAVING
AN ADJUSTABLE BUOYANCY CHAMBER**

5 Related Application

The instant application is a continuation-in-part of prior provisional application no. 60/606,335 filed September 1, 2004.

Field of the Invention

10 The present invention relates generally to oil and gas exploration and production, and in a specific, non-limiting embodiment, to a system and method of installing and maintaining an offshore exploration and production system having an adjustable buoyancy chamber.

15 Background of the Invention

Innumerable systems and methods have been employed in efforts to find and recover hydrocarbon reserves around the world. At first, such efforts were limited to land operations involving simple but effective drilling methods that satisfactorily recovered reserves from large, productive fields. As the number of
20 known producing fields dwindled, however, it became necessary to search in ever more remote locales, and to move offshore, in the search for new resources. Eventually, sophisticated drilling systems and advanced signal processing techniques enabled oil and gas companies to search virtually anywhere in the world for recoverable hydrocarbons.

25 Initially, deepwater exploration and production efforts consisted of expensive, large scale drilling operations supported by tanker storage and transportation systems, due primarily to the fact that most offshore drilling sites are associated with difficult and hazardous sea conditions, and thus large scale operations provided the most stable and cost-effective manner in which to search
30 for and recover hydrocarbon reserves. A major drawback to the large-scale paradigm, however, is that explorers and producers have little financial incentive

to work smaller reserves, since potential financial recovery is generally offset by the lengthy delay between exploration and production (approximately 3 to 7 years) and the large capital investment required for conventional platforms and related drilling and production equipment. Moreover, complex regulatory controls and industry-wide risk aversion have led to standardization, leaving operators with few opportunities to significantly alter the prevailing paradigm. As a result, offshore drilling operations have traditionally been burdened with long delays between investment and profit, excessive cost overruns, and slow, inflexible recovery strategies dictated by the operational environment.

More recently, deepwater sites have been found in which much of the danger and instability present in such operations is avoided. For example, off the coast of West Africa, Indonesia and Brazil, potential drilling sites have been identified where surrounding seas and weather conditions are relatively mild and calm in comparison to other, more volatile sites such as the Gulf of Mexico and the North Sea. These recently discovered sites tend to have favorable producing characteristics, yield positive exploration success rates, and admit to production using simple drilling techniques similar to those employed in dry land or near-shore operations.

However, since lognormal distributions of recoverable reserves tend to be spread over a large number of small fields, each of which yield less than would normally be required in order to justify the expense of a conventional large-scale operation, these regions have to date been underexplored and underproduced relative to its potential. Consequently, many potentially productive smaller fields have already been discovered, but remain undeveloped due to economic considerations. In response, explorers and producers have adapted their technologies in an attempt to achieve greater profitability by downsizing the scale of operations and otherwise reducing expense, so that recovery from smaller fields makes more financial sense, and the delay between investment and profitability is reduced.

For example, in published Patent Application No. US 2001/0047869 A1 and a number of related pending applications and patents issued to Hopper *et al.*,

various methods of drilling deepwater wells are provided in which adjustments to the drilling system can be made so as to ensure a better recovery rate than would otherwise be possible with traditional fixed-well technologies. However, the Hopper system cannot be adjusted during completion, testing and production of the well, and is especially ineffective in instances where the well bore starts at a mud line in a vertical position. The Hopper system also fails to support a variety of different surface loads, and is therefore self-limiting with respect to the flexibility drillers desire during actual operations.

In U.S. Letters Patent No. 4,223,737 to O'Reilly, a method is disclosed in which the problems associated with traditional, vertically oriented operations are addressed. The method of O'Reilly involves laying out a number of interconnected, horizontally disposed pipes in a string just above the sea floor (along with a blow out preventer and other necessary equipment), and then using a drive or a remote operated vehicle to force the string horizontally into the drilling medium. The O'Reilly system, however, is inflexible in that it fails to admit to practice while the well is being completed and tested. Moreover, the method utterly fails to contemplate functionality during production and workover operations. In short, the O'Reilly reference is helpful only during the initial stages of drilling a well, and would therefore not be looked to as a systemic solution for establishing and maintaining a deepwater exploration and production operation.

Other offshore operators have attempted to solve the problems associated with deepwater drilling by effectively "raising the floor" of an underwater well by disposing a submerged wellhead above a self-contained, rigid framework of pipe casing that is tensioned by means of a gas filled, buoyant chamber. For example, as seen in prior U.S. Letters Patent No. 6,196,322 B1 to Magnussen, the Atlantis Deepwater Technology Holding Group has developed an artificial buoyant seabed (ABS) system, which is essentially a gas filled buoyancy chamber deployed in conjunction with one or more segments of pipe casing disposed at a depth of between 600 and 900 feet beneath the surface of a body of water. After the ABS wellhead is fitted with a blowout preventer during drilling, or with a production tree during production, buoyancy and tension are imparted by the ABS to a lower

connecting member and all internal casings. The BOP and riser (during drilling) and production tree (during production), are supported by the lifting force of the buoyancy chamber. Offset of the wellhead is reasonably controlled by means of vertical tension resulting from the buoyancy of the ABS.

5 The Atlantis ABS system is deficient, however, in several practical respects. For example, the '322 Magnussen patent specifically limits deployment of the buoyancy chamber to environments where the influence of surface waves is effectively negligible, *i.e.*, at a depth of more than about 500 feet beneath the surface. Those of ordinary skill in the art will appreciate that deployment at such
10 depths is an expensive and relatively risk-laden solution, given that installation and maintenance can only be carried out by deep sea divers or remotely operated vehicles, and the fact that a relatively extensive transport system must still be installed between the top of the buoyancy chamber and the bottom of an associated recovery vessel in order to initiate production from the well.

15 The Magnussen system also fails to contemplate multiple anchoring systems, even in instances where problematic drilling environments are likely to be encountered. Moreover, the system lacks any control means for controlling adjustment of either vertical tension or wellhead depth during production and workover operations, and expressly teaches away from the use of lateral stabilizers
20 that could enable the wellhead to be deployed in shallower waters subject to stronger tidal and wave forces.

 Thus, there is plainly a widespread need for a system and method of disposing an offshore wellhead in a manner such that drillers can adjust both the depth of a wellhead and the vertical tension applied to associated pipe casing
25 throughout the duration of exploration and production operations. There is also a need for an adjustable buoyancy chamber system capable of maintaining approximately constant vertical tension on an associated drilling or production string, and adjusting either the height of a wellhead at any time during exploration and production by releasing additional lengths of tension line from a buoyancy
30 chamber height adjustment member. There is also a need for an offshore exploration and production system that flexibly admits to use in connection with

both deepwater and shallow target horizons, without necessarily being configured to conform to any particular operational depth.

Brief Description of the Drawings

5 Figure 1 is a side view of an offshore exploration and production system in which an adjustable buoyancy chamber is employed to adjust the height or depth of an associated well terminal member.

Figures 2A and 2B are side views of an offshore exploration and production system, in which lateral and vertical forces on an adjustable buoyancy chamber are held approximately constant while the height of an associated well terminal member is adjusted by releasing additional lengths of tension line.

10

Summary of the Invention

A system and method of establishing an offshore exploration and production system is provided, in which a well casing is disposed in communication with an adjustable buoyancy chamber and a well hole bored into the floor of a body of water. A lower connecting member joins the well casing and the chamber, and an upper connecting member joins the adjustable buoyancy chamber and a well terminal member. The chamber's adjustable buoyancy enables an operator to vary the height or depth of the well terminal member, and to vary the vertical tension imparted to drilling and production strings throughout exploration and production operations. Also provided is a system and method of adjusting the height or depth of a wellhead while associated vertical and lateral forces remain approximately constant. A variety of well isolation members, lateral stabilizers and anchoring means, as well as several methods of practicing the invention, are also disclosed.

15

20

25

Detailed Description

Referring now to the specific, non-limiting embodiment of the invention depicted in Figure 1, an offshore exploration and production system is provided, comprising a well casing 2 installed in communication with a submerged well 1

30

and an adjustable buoyancy chamber 9, wherein a lower connecting member 5 is disposed between the well casing and the adjustable buoyancy chamber. In a presently preferred embodiment, the well 1 is accessed from above by means of a well hole 3 that has been bored into an associated sea floor surface. In a typical embodiment, a well casing 2 is set into the hole in a firm and secure manner, and then cemented into place using known downhole technology. In other embodiments, a well casing is securely set into the well hole 3, and a fluid transport member, such as a smaller-diameter pipe or pipe casing, is inserted into well casing 2. Once a desired fit has been achieved, the outer surface of the fluid transport member is cemented or set with a packer to the inner surface of the well casing. Those of ordinary skill in the art will appreciate that while the embodiment described above refers to but a single well, the offshore exploration and production system disclosed herein can be readily adapted to simultaneously work multiple neighboring wells without departing from the scope or spirit of the invention.

According to a one embodiment, a well isolation member 4 is disposed between well casing 2 and a lower connecting member 5. In some embodiments, well isolation member 4 comprises one or more ball valves, which, if lower connecting member 5 is removed, can be closed so that the well is effectively shut in. In further embodiments, well isolation member 4 comprises a blowout preventer or a shear ram that can be maintained in either an open or closed position in order to provide access to, or to instead shut in, the contents of well 1.

In other embodiments, lower connecting member 5 further comprises one or more receiving members disposed to receive an attachment member disposed on well isolation member 4. In an alternative embodiment, lower connecting member 5 comprises an attachment member for attaching said lower connecting member 5 to a receiving member disposed on well isolation member 4. Methods and means of securely fastening lower connecting member 5 to well isolation member 4 are known to those of ordinary skill in the art, and may comprise one or more of a wide variety of fastening techniques, *e.g.*, hydraulic couplers, various nut and bolt assemblies, welded joints, pressure fittings (either with or without gaskets), swaging, *etc.*, without departing from the scope or spirit of the present invention.

Likewise, lower connecting member 5 may comprise any known connecting means appropriate for the specific application contemplated by operators. For example, in various embodiments, lower connecting member 5 comprises one or more of segments of riser, riser pipe, and/or pipe casing. In some embodiments, lower connecting member 5 comprises a concentric arrangement, for example, a fluid transport member having a smaller outer diameter than the inner diameter of a pipe casing in which the fluid transport member is housed.

In further embodiments, lower connecting member 5 is disposed in communication with one or more lateral stabilizers 6, which, when deployed in conjunction a plurality of tension lines 7, effectively controls horizontal offset of the system. By utilizing the buoyant forces of adjustable buoyancy chamber 9, lower connecting member 5 is drawn taut and held in a stable position.

In an alternative embodiment, one or more stabilizers 6 control horizontal offset of lower connecting member 5, and the height or depth of an associated well terminal member 14 is adjusted by varying the length of upper connecting member 12. In some embodiments, the vertical tension of lower connecting member 5 is held approximately constant while the height or depth of well terminal member 14 is adjusted. In further embodiments, the height or depth of well terminal member 14 is held approximately constant, while the vertical tension imparted by adjustable buoyancy chamber 9 on lower connecting member 5 is adjusted. In still further embodiments, the height or depth of well terminal member 14 and the vertical tension applied to lower connecting member 5 are held approximately constant, while lateral adjustments are performed using lateral stabilizer 6 and one or more of tension lines 7.

In certain embodiments, one or more lateral tension lines 7 are individually adjustable, whereas in other embodiments, the tension lines 7 are collectively adjustable. In further embodiments, one or more tension lines 7 are both individually and collectively adjustable. In still further embodiments, the one or more lateral stabilizers 6 are disposed in communication with a tension measuring means, so that a fixed or predetermined amount of lateral tension can be applied to lower connecting member 5 in order to better control system offset. In some

embodiments, the tension lines 7 are anchored to the sea floor by means of an anchoring member 8, for example, a suction type anchor, or alternatively, a mechanical or conventional deadweight type anchor.

In a presently preferred embodiment, adjustable buoyancy chamber 9 is approximately annular in shape, so that lower connecting member 5 can be passed through a void longitudinally disposed in a central portion of the device. In further embodiments, adjustable buoyancy chamber 9 further comprises a plurality of inner chambers. In still further embodiments, each of the chambers is independently operable, and different amounts of air or gas (or another fluid) are disposed in the chambers to provide greater adjustable buoyancy control. In one example embodiment, adjustable buoyancy chamber 9 further comprises a fluid ballast that can be ejected from the chamber, thereby achieving greater chamber buoyancy and lending additional vertical tension to lower connecting member 5. Those of ordinary skill in the art will appreciate that many appropriate fluid ballast can be used to increase or retard buoyancy; for example, compressed air is an appropriate fluid that is both inexpensive and readily available.

In some embodiments, adjustable buoyancy chamber 9 further comprises a ballast input valve, so that a fluid ballast can be injected into the chamber from an external source, for example, through an umbilical line run to the surface or a remote operated vehicle, so that an operator can deliver a supply of compressed gas to the chamber via the umbilical, thereby adjusting buoyancy characteristics as desired. In other embodiments, the fluid input valve is disposed in communication with one or more pumps or compressors, so that the fluid ballast is delivered to the chamber under greater pressure, thereby effecting the desired change in buoyancy more quickly and reliably.

In other embodiments, adjustable buoyancy chamber 9 further comprises a ballast output valve, so that ballast can be discharged from the chamber. In instances where air or another light fluid is injected into the chamber while water or another heavy liquid is discharged, the chamber will become more buoyant and increase vertical tension on lower connecting member 5. Conversely, if water or another heavy liquid is injected into the chamber while air is bled out, the chamber

will lose buoyancy, thereby lessening vertical tension on lower connecting member 5.

In alternative embodiments, the ballast output valve is disposed in communication with one or more pumps or compressors, so that ballast is ejected from the chamber in a more reliable and controlled manner. In some 5 embodiments, the ballast output valve is disposed in communication with an umbilical, so that ballast ejected from the chamber can be recovered or recycled at the surface. In any event, a principle advantage of the present invention is that adjustments to the chamber's buoyancy and tensioning properties, and the ability 10 to control the height of the well terminal member 14, can be performed at any time during either exploration or production, due to the various ballast input and output control means disposed about the body of the chamber.

In further embodiments, adjustable buoyancy chamber 9 is further disposed in communication with one or more tension lines 10 provided to anchor the 15 adjustable buoyancy chamber to the sea floor. As before, tension lines 10 are anchored to the sea floor using known anchoring technology, for example, suction anchors or dead weight type anchors, *etc.* The one or more tension lines 10 can also provide additional lateral stability for the system, especially during operations in which more than one well is being worked. In one embodiment, the one or 20 more tension lines 10 are run from the adjustable buoyancy chamber 9 to the surface, and then moored to other buoys or a surface vessel, *etc.*, so that even greater lateral tension and system stability are achieved. In further embodiments, the tension lines 10 are individually adjustable, whereas in other embodiments, the tension lines 10 are collectively controlled. In still further embodiments, the one 25 or more tension lines 10 are both individually and collectively adjustable.

In one example embodiment, adjustable buoyancy chamber 9 is disposed in communication with a vertical tension receiving member 11. In another embodiment, the vertical tension receiving member 11 is equipped with a tension measuring means (*e.g.*, a load cell, strain gauge, *etc.*), so that vertical tension 30 applied to lower connecting member 5 is imparted in a more controlled and efficient manner. In another embodiment, the buoyant force applied to tension

receiving member 11 is adjusted by varying the lengths of tension lines 10, while the buoyancy of adjustable buoyancy chamber 9 is held approximately constant. In a further embodiment, the buoyancy of adjustable buoyancy chamber 9 is controlled by means of one or more individually selectable ballast exhaust ports
5 disposed about the body of the chamber, which vent excess ballast fluid to the surrounding sea. In still further embodiments, the open or closed state of the ballast exhaust ports are individually controlled using port controllers known to those of ordinary skill in the art (*e.g.*, plugs, seacocks, *etc.*)

In a presently preferred embodiment, the system is disposed so that a well
10 terminal member 14 installed above buoyancy chamber 9 is submerged to a depth at which maintenance and testing can be carried out by SCUBA divers using lightweight, flexible diving equipment, for example, at a depth of about 100 to 300 feet beneath the surface. In some embodiments, the well terminal member 14 is submerged only to the minimum depth necessary to provide topside access to the
15 hulls of various surface vessels servicing the well, meaning that well terminal member 14 could also be disposed at a much shallower depth, for example, a depth of about 50 to 100 feet. In alternative embodiments, well terminal member 14 is disposed at depths of less than 50 feet, or greater than 300 feet, depending upon the actual conditions surrounding operations. In still further embodiments, well
20 terminal member 14 is disposed either at the surface or above the surface of the water, and a blowout preventer or a production tree is installed by workers operating aboard a service platform or surface vessel. This "damp tree" model avoids the need to assemble long subsurface riser stacks, as would generally be required during deepwater operations. Moreover, disposing the well terminal
25 member at or near the surface also permits testing and maintenance to be carried out by SCUBA divers or surface crews, without the need for expensive and time-consuming remote operated vehicle operations.

In some embodiments, well terminal member 14 further comprises either a blowout preventer or a production tree. In a presently preferred embodiment,
30 however, well terminal member 14 further comprises a combined blowout

preventer and production tree assembly configured so as to facilitate simplified well intervention operations.

In some embodiments, lower connecting member 5 terminates within the void formed in a center portion of the annular chamber 9, at which point an upper connecting member 12 becomes the means by which fluids are transported up to the wellhead. In other embodiments, lower connecting member 5 does not terminate within the void formed in a center portion of the annular chamber, but instead runs through the void and is subsequently employed as an upper connecting member 12 disposed between the chamber and the wellhead. In other embodiments, a vertical tension receiving member 11 is disposed between the buoyancy chamber 9 and upper connecting member 12, so that the chamber's buoyant forces are transferred to the vertical tension receiving means 11, thereby applying vertical tension to the drilling or production string extended below the chamber.

In further embodiments, upper connecting member 12 further comprises a well isolation member 13, *e.g.*, one or more ball valves or blowout preventers, used to halt fluid flow in the event that well terminal member 14 is either removed or disabled, for example, during testing and maintenance operations. Those of ordinary skill in the art will appreciate that the precise types and exact locations of isolation valves 13 employed in the system are variable and flexible, the only real requirement being that the valves are capable of allowing or preventing fluid flow from the well 1 during periods in which testing or maintenance, or even an emergency safety condition, are present.

For example, well terminal member 14 can be equipped with a production tree so that a production hose disposed on a surface vessel can be attached to the system and production can commence. Alternatively, well terminal member 14 can terminate in a blowout preventer, so that the well will not blow out during drilling operations. In other embodiments, well terminal member 14 terminates in a combined production tree and blowout preventer assembly to facilitate simplified well intervention operations.

Turning now to the specific, non-limiting embodiments of the invention depicted in Figures 2A and 2B, a system and method of establishing a height-variable well terminal member is provided, comprising a lower fluid transport pipe 21, an inner well casing 22, an outer well casing 23, and a wellhead 24. In some 5 embodiments, a well isolation member 25 is disposed above the wellhead 24, so that the well can be closed off or shut in if desired.

In the example embodiment depicted in Figure 2A, well isolation member 25 further comprises one or more ball valves that can be adjustably opened or closed as desired by an operator. A lower connecting member 26 having one or 10 more interior seals 27 and an interior polished bore 28 houses a fluid transport member 29 such that the height of fluid transport member 29 is variably adjustable within a body portion of lower connecting member 26 in response to vertical lifting forces imparted by adjustable buoyancy chamber 30. Various lengths of pipe define the height of an upper connecting member disposed between the 15 buoyancy chamber 30 and a well terminal member 36. In some embodiments, an upper well isolation member 35, such as a ball valve or a blowout preventer, is disposed in communication with the upper connecting member between buoyancy chamber 30 and well terminal member 36.

In some embodiments, the system is moored to the sea floor using one or 20 more mooring lines 31 connected to a first vertical tension receiving means 32a, while buoyancy chamber 30 is raised or lowered by either spooling-out or reeling-in lengths of one or more tension lines 37 disposed between a second vertical tension receiving means 32b and a chamber height adjustment means 33. As adjustable buoyancy chamber 30 rises, vertical tension is applied to vertical 25 tension receiving member 34, which in turn lifts well terminal member 36 up toward the surface.

As seen in the example embodiment depicted in Figure 2B, the height of both the well terminal member 36 and fluid transport member 29 are vertically 30 adjusted by increasing the length of tension lines 37 using chamber height adjustment means 33, even as vertical and lateral tension on mooring lines 31 and tension lines 37 remains approximately constant. In one embodiment, vertical

tension on lower connecting member 26 is also kept approximately constant during this process, since fluid transport member 29 is moved vertically within a body portion of lower connecting member 26. In another embodiment, a second, lower adjustable buoyancy chamber is added to the system to maintain tension on lower
5 connecting member 26, while the height of the well terminal member is adjusted as described above.

The foregoing specification is provided for illustrative purposes only, and is not intended to describe all possible aspects of the present invention. Moreover, while the invention has been shown and described in detail with respect to several
10 exemplary embodiments, those of ordinary skill in the pertinent arts will appreciate that minor changes to the description, and various other modifications, omissions and additions may also be made without departing from either the spirit or scope thereof.

Claims

1. An offshore exploration and production system, the system comprising:
- 5 a. a well casing (2) disposed in communication with an offshore well (1);
- b. an adjustable buoyancy chamber (9); and
- c. a lower connecting member disposed between said well casing (2) and said adjustable buoyancy chamber (9).
- 10 2. The system of claim 1, further comprising:
- a. one or more adjustable buoyancy chambers (9); or
- b. a well casing (2) disposed in communication with a hole (3) bored into an associated sea floor surface; or
- c. a well isolation member (4) disposed between said adjustable
- 15 buoyancy chamber (9) and said lower connecting member (5);
- i. said well isolation member (4) preferably further comprises one or more ball valves or a blowout preventer preferably comprising a shear ram; or
- ii. said lower connecting member (5) preferably further
- 20 comprises a receiving member for receiving an attachment member disposed on said isolation member (4) or an attachment member for attaching said lower connecting member (5) to a receiving member disposed on said isolation member (4).
- 25
3. The system of claim 1, wherein said lower connecting member (5) further comprises:
- a. a riser; or
- b. a riser pipe; or
- 30 c. a casing; or

- d. a fluid transport member disposed within an interior portion of said lower connecting member, said fluid transport member is preferably height adjustable in response to a buoyant force imparted by said adjustable buoyancy chamber (9).

5

- 4. The system of claim 1, wherein said lower connecting member (5) is disposed in communication with one or more lateral stabilizers (6);

- a. said one or more lateral stabilizers (6) preferably further comprises one or more adjustable lateral stabilizers; or

10

- b. said one or more lateral stabilizers (6) is preferably disposed in communication with one or more tension lines (7);

- i. said one or more tension lines (7) preferably further comprises one or more individually adjustable tension lines; or

15

- ii. said one or more tension lines (7) are preferably disposed in communication with one or more anchoring members (8).

- 5. The system of claim 2, wherein said one or more adjustable buoyancy chambers (9) further comprises one or more approximately annular adjustable buoyancy chambers, said lower connecting member (5) is preferably longitudinally disposed through a void formed in said one or more approximately annular adjustable buoyancy chambers.

20

- 6. The system of claim 2, wherein one or more of said one or more adjustable buoyancy chambers (9) further comprises a plurality of inner chambers.

25

- 7. The system of claim 1, wherein said adjustably buoyancy chamber further comprises:

30

- a. a fluid ballast preferably comprising a supply of compressed gas; or
- b. a ballast input valve;

- i. said ballast input valve is preferably disposed in communication with one or more of an umbilical and a remote operated vehicle; or
- ii. said ballast input valve is preferably disposed in communication with a pump; or
- iii. said ballast input valve is preferably disposed in communication with a compressor; or

c. a ballast output valve:

- i. said ballast input valve is preferably disposed in communication with one or more of an umbilical and a remote operated vehicle; or
- ii. said ballast input valve is preferably disposed in communication with a pump; or
- iii. said ballast input valve is preferably disposed in communication with a compressor.

8. The system of claim 1, wherein said adjustable buoyancy chamber is:

a. disposed in communication with one or more tension lines (10);

- i. said one or more tension lines (10) preferably further comprises one or more individually adjustable tension lines; or
- ii. said one or more tension lines (10) is preferably disposed in communication with one or more anchoring members; or

b. disposed in communication with a vertical tension receiving member (11), said tension receiving member is preferably disposed in communication with a tension measuring means preferably comprising a load cell; or

c. submerged in a body of water at a depth of between about 100 feet and about 300 feet; or

d. submerged in a body of water at a depth of less than about 100 feet;
or

e. submerged in a body of water at a depth of greater than about 300 feet; or

5 f. disposed in communication with an upper well isolation member;
i. preferably comprising a ball valve; or
ii. preferably comprising a blowout preventer preferably comprising a shear ram; or

10 g. disposed in communication with an upper connecting member (12),
said upper connecting member (12) is preferably disposed in communication with a well terminal member (14) preferably comprising;

i. a production tree; or
15 ii. a blowout preventer; or
iii. a combined production tree and blowout preventer assembly.

9. The system of claim 1, wherein a well terminal member (14) disposed above said adjustable buoyancy chamber (9) is disposed above a surface of
20 a body of water.

10. A method of installing and maintaining an offshore exploration and production system, the method of comprising the steps of:

25 a. disposing a well casing (2) in communication with an offshore well;
and

b. disposing a lower connecting member (5) between said well casing (2) and an adjustable buoyancy chamber (9).

11. The method of claim 10, further comprising the steps of:

30 a. disposing one or more adjustable buoyancy chambers (9) in communication with said well casing (2), the method preferably

further comprising cementing said well casing (2) into a hole (3) bored into a sea floor surface;

- b. disposing a well isolation member between said adjustable buoyancy chamber (9) and said lower connecting member (5), preferably further comprising:

i. disposing a well isolation member (4) having one or more ball valves;

ii. disposing a well isolation member (4) having a blowout preventer, said disposing a blowout preventer preferably further comprises disposing a blowout preventer having a shear ram; or

iii. disposing a well isolation member (4) having an attachment member for attaching said well isolation member to a receiving member disposed on said lower connecting member; or

iv. disposing a well isolation member (4) having a receiving member for receiving an attachment member disposed on said lower connecting member (5).

12. The method of claim 10, wherein said disposing a lower connecting member (5) further comprises the steps of:

a. disposing a riser;

b. disposing a riser pipe; or

c. disposing a casing; or

d. disposing a fluid transport member housed within an interior portion of said lower connecting member, the method preferably further comprising adjusting the length of one or more associated tension lines so as to variably adjust the height of said fluid transport member; or

e. disposing a lower connecting member in communication with one or more lateral stabilizers (6), the method preferably further comprising the steps of:

5 i. disposing a lower connecting member (5) in communication with one or more adjustable lateral stabilizers; or

10 ii. disposing said one or more lateral stabilizers in communication with one or more tension lines (7), the method preferably further comprising disposing said one or more later stabilizers (6) in communication with one or more adjustable tension lines or the method preferably further comprising disposing said one or more tension lines (7) in communication with one or more anchoring members (8).

15 13. The method of claim 11, further comprising the steps of:

20 a. disposing one or more approximately annular adjustable buoyancy chambers (9), the method preferably further comprising disposing said lower connecting member (5) longitudinally through a void formed in said one or more approximately annular adjustable buoyancy chambers; or

b. disposing one or more adjustable buoyancy chambers (9) having a plurality of inner chambers.

25 14. The method of claim 10, further comprising disposing an adjustable buoyancy chamber (9) having;

30 a. a fluid ballast, said disposing an adjustable buoyancy chamber (9) having a fluid ballast preferably further comprises disposing an adjustable buoyancy chamber (9) having a supply of compressed gas;

or

b. a fluid input valve, the method preferably further comprising;

- i. disposing said fluid input valve in communication with one or more of an umbilical and a remote operated vehicle;
 - ii. disposing said fluid input valve in communication with a pump; or
 - iii. disposing said fluid input valve in communication with a compressor; or
 - c. a fluid output valve, the method preferably further comprising the steps of:
 - i. disposing said fluid input valve in communication with one or more of an umbilical and a remote operated vehicle;
 - ii. disposing said fluid input valve in communication with a pump; or
 - iii. disposing said fluid input valve in communication with a compressor.

15. The method of claim 10, further comprising disposing an adjustable buoyancy chamber in communication with;

a. one or more adjustable tension lines (10), the method preferably further comprising the steps of:

i. disposing an adjustable buoyancy chamber (9) in communication with one or more individually adjustable tension lines; or

ii. disposing said one or more tension lines (10) in communication with one or more anchoring members; or

b. a tension receiving member (11), the method preferably further comprising disposing said tension receiving member (11) in communication with a tension measuring means, said disposing said tension receiving member (11) in communication with a tension

measuring means preferably further comprises disposing said tension receiving member in communication with a load cell; or

- c. submersing an adjustable buoyancy chamber in a body of water to a depth of between about 100 feet and about 300 feet; or
- 5 d. submersing an adjustable buoyancy chamber in a body of water to a depth of less than about 100 feet; or
- e. submersing an adjustable buoyancy chamber in a body of water to a depth of greater than about 300 feet; or
- f. disposing a well terminal member (14) above said adjustable
10 buoyancy chamber (9) in a manner such that said well terminal member (14) is disposed above a surface of a body of water; or
- g. disposing an adjustable buoyancy chamber (9) in communication with a well isolation member (4), the method preferably further comprising:

- 15 i. disposing an adjustable buoyancy chamber in communication with a well isolation member (4) having a ball valve; or

- ii. disposing an adjustable buoyancy chamber in
20 communication with a well isolation member (4) having a blowout preventer, the method preferably further comprising disposing an adjustable buoyancy chamber (9) in communication with a blowout preventer having a shear ram; or

- h. disposing an adjustable buoyancy chamber (9) in communication
25 with an upper connecting member (12), the method preferably further comprising disposing said upper connecting member (12) in communication with a well terminal member (14), the method preferably further comprising;

- i. disposing said upper connecting member (12) in
30 communication with a blowout preventer; or

- ii. disposing said upper connecting member (12) in communication with a production tree; or
- iii. disposing said upper connecting member (12) in communication with a combined production tree and blowout preventer assembly;

5

16. The use of an offshore exploration and production system, wherein said system comprises:

- a. a well casing (2) disposed in communication with an offshore well (1);
- b. an adjustable buoyancy chamber (9); and
- c. a lower connecting member (5) disposed between said well casing (2) and said adjustable buoyancy chamber (9),

10

the use of said system being for the exploration and production of oil and

15 gas.

17. Oil and gas obtained from a method of installing and maintaining an offshore exploration and production system, wherein the method comprises the steps of:

- a. disposing a well casing (2) in communication with an offshore well (1); and
- b. disposing a lower connecting member (5) between said well casing (2) and an adjustable buoyancy chamber (9).

20

DUPLICATA

1/2

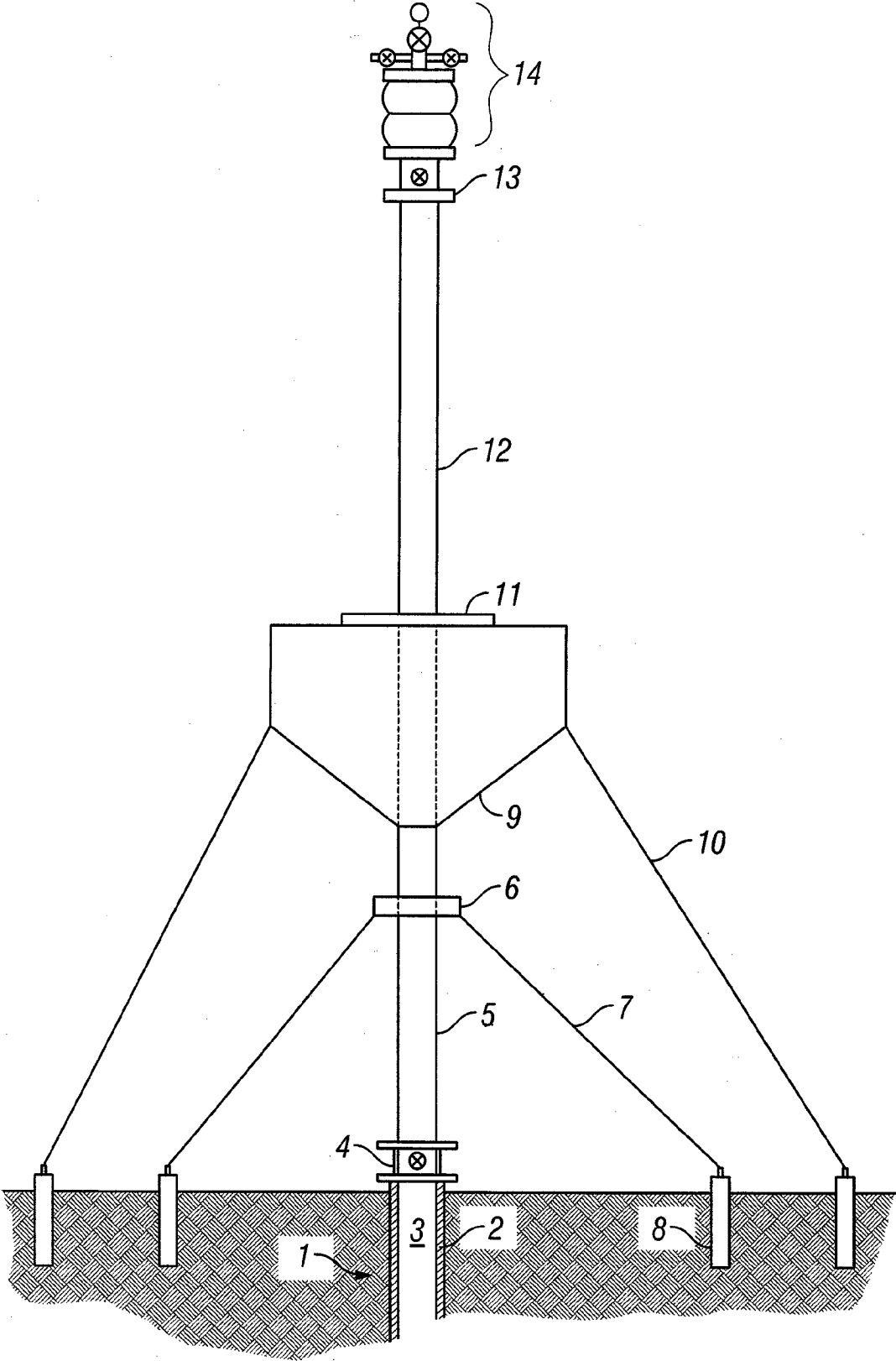

DUPLICATA

FIG. 1

013023

2/2

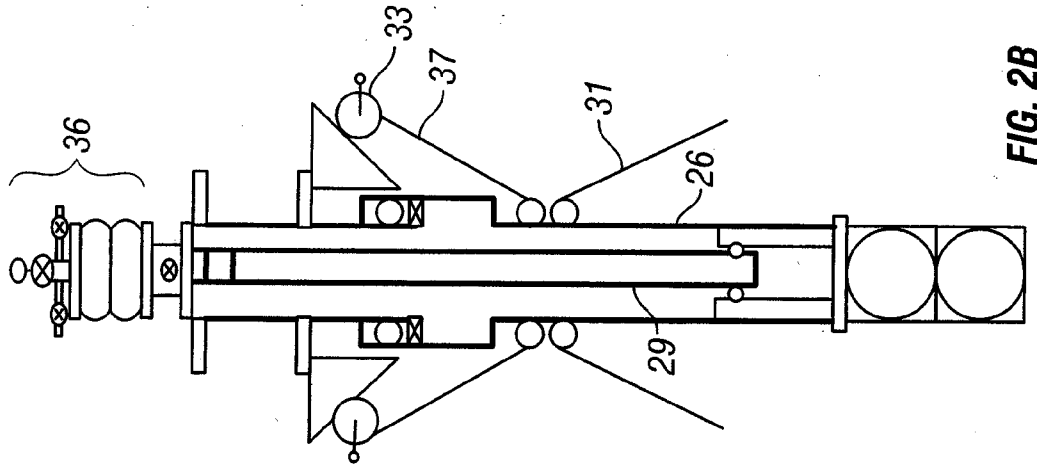

FIG. 2B

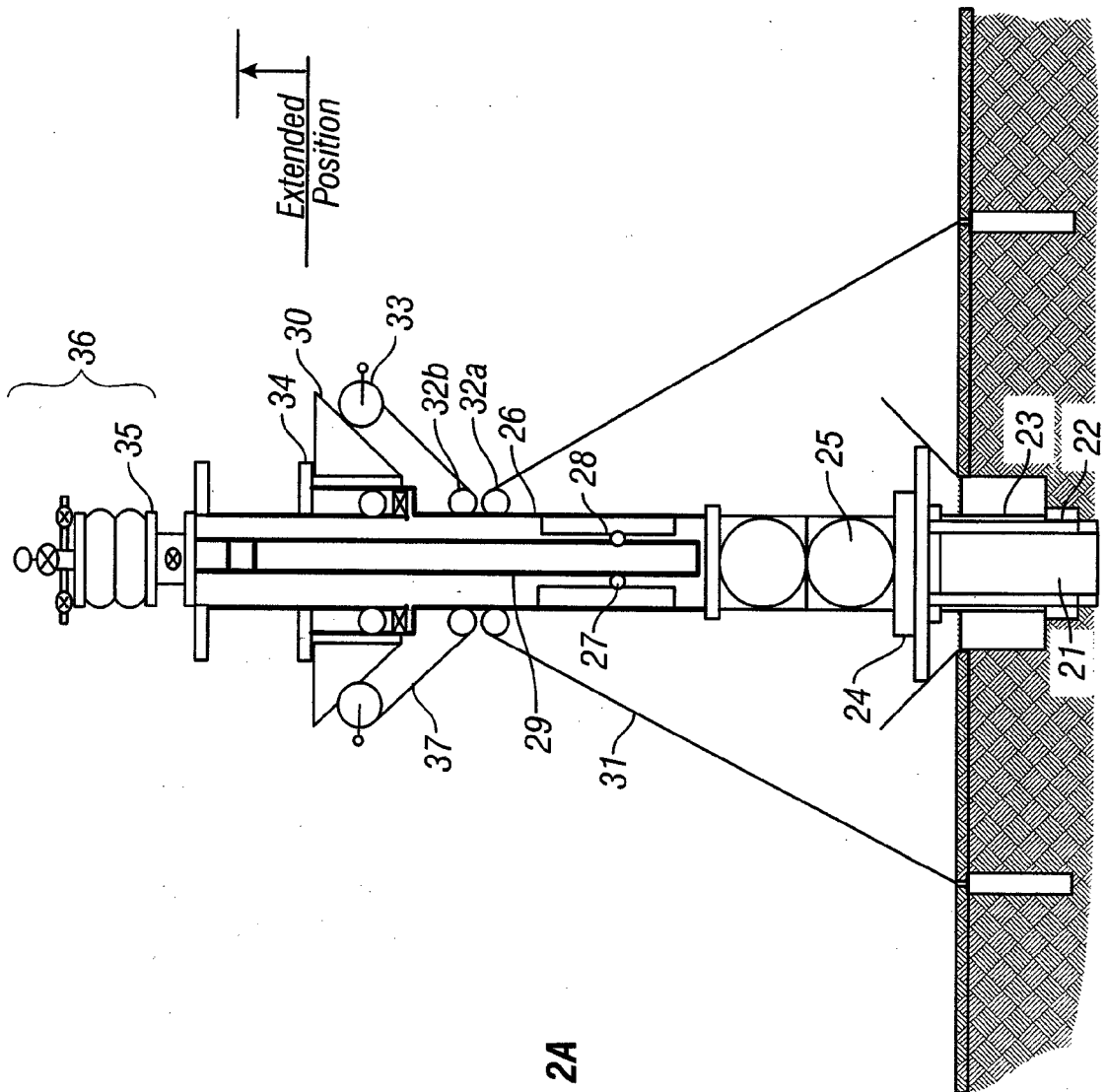

FIG. 2A

DUPLICATA