



(19) **United States**

(12) **Patent Application Publication**
LANG et al.

(10) **Pub. No.: US 2002/0014975 A1**

(43) **Pub. Date: Feb. 7, 2002**

(54) **REARVIEW MIRROR ASSEMBLY WITH INTEGRAL DISPLAY ELEMENT**

(30) **Foreign Application Priority Data**

Jan. 22, 1999 (DE)..... 199 02 487.1

(76) Inventors: **HEINRICH LANG**, ERGERSHEIM (DE); **CHRISTOPHER RENNER**, IPSHEIM (DE); **WOLFGANG SEIBOTH**, BAD WINDSHEIM (DE)

Publication Classification

(51) **Int. Cl.⁷** **G08B 5/22**

(52) **U.S. Cl.** **340/815.45; 340/815.4**

(57) **ABSTRACT**

A rearview mirror (2) is described, especially for motor vehicles, in which in the direction of a top view, at least one radiation emitting display element (8) is placed behind the mirror pane (6), which emits through the said mirror pane (6). The display element (8) can emit light in the visible range or in the infrared range. Said display element (8) is preferred as a light emitting diode (10) or a seven segment display. The object of the present invention can, for instance, be combined with a so-called back-up aid, whereby then the display element(s) (8) can display back-up distance data or distance codes between the tailgate and an obstruction or a target of back-up maneuvering.

Correspondence Address:

DORITY & MANNING, P.A.
POST OFFICE BOX 1449
GREENVILLE, SC 29602-1449 (US)

(*) Notice: This is a publication of a continued prosecution application (CPA) filed under 37 CFR 1.53(d).

(21) Appl. No.: **09/304,168**

(22) Filed: **Apr. 30, 1999**

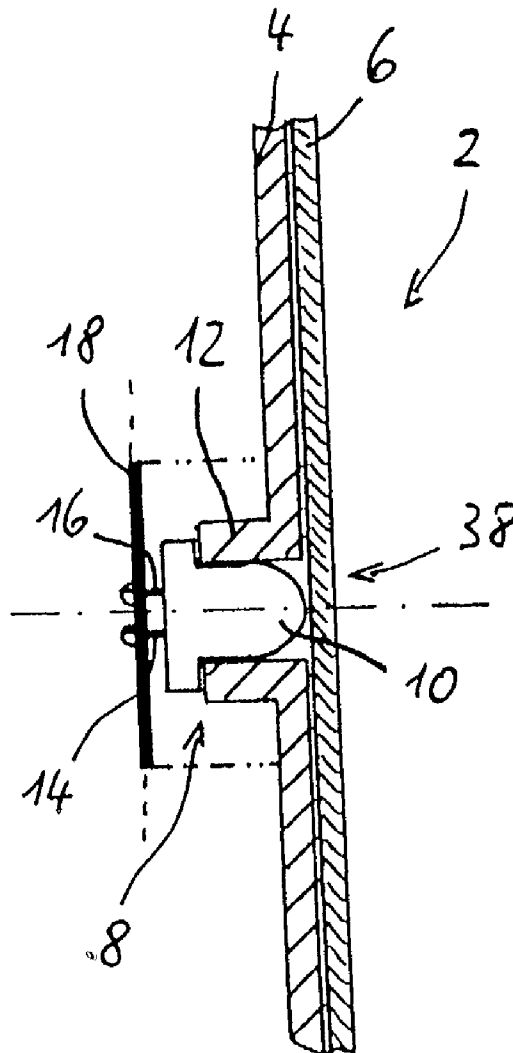

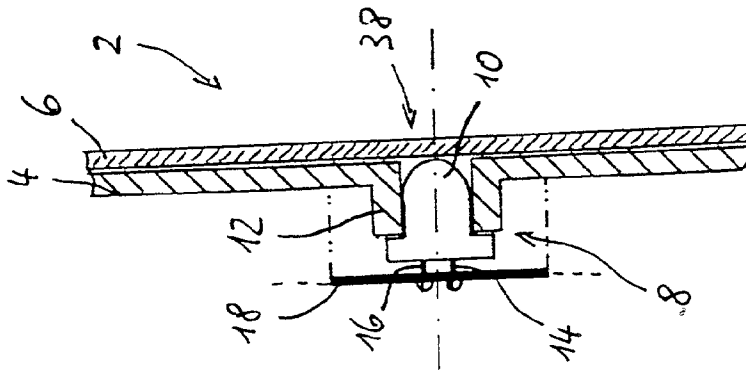

FIG. 1

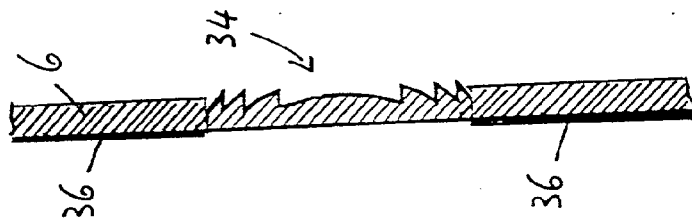

FIG. 3

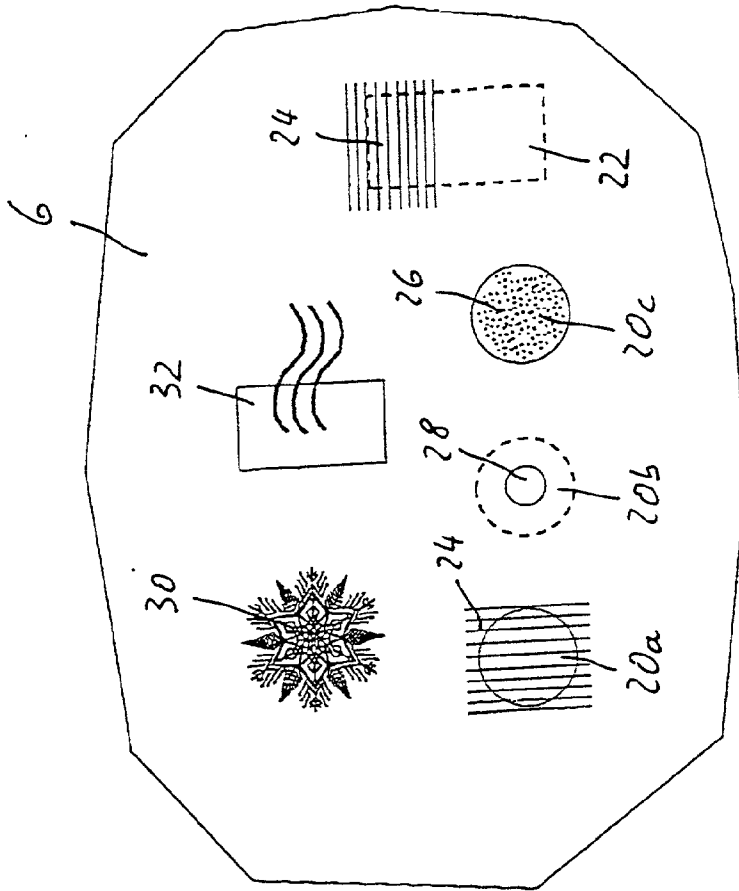

FIG. 2

REARVIEW MIRROR ASSEMBLY WITH INTEGRAL DISPLAY ELEMENT

[0001] The invention concerns a rearview mirror, in particular, for motor vehicles, in accord with the generic concept of claim 1 of the present patent.

[0002] It is common knowledge to equip vehicles with so-called back-up aid facilities, which feature one or more sensors. The sensors may, for instance, operate on an ultrasonic basis and be placed on the rear of the vehicle. Evaluation and display apparatuses, connected to said sensors, may be placed in the cockpit or the driver's compartment. In particular, for large commercial vehicles, such trucks as semi-trailers, articulated vehicles, and the like, back-up aid facilities furnish great help for the driver. With such help in back-up maneuvering, a display can be made of the distance to an obstruction or to a target of the maneuvering, for instance, to a loading dock. The sensor(s) placed at the rear of a vehicle determine the distance to an obstruction or the said target and this distance is displayed on a monitor in the driver's compartment. The distance can be shown either directly in meters and centimeters by means of a seven segment display, or the display will exhibit one or more of preferably different colored signal lamps (Light Emitting Diodes, hereinafter LEDs) by means of which the distance to an obstruction or the target of the maneuvering is shown in definite increments. Additionally, acoustic signals can be employed.

[0003] Where back-up maneuvering is concerned, the driver is, in great measure, dependent upon the information, which is seen in the outside rearview mirror. With the aid of the rearview mirrors, which are, as a rule, on both sides of the cab, the driver is in a position to maneuver safely. Depending, of course, on appropriate know-how and experience. In connection with a back-up aid of the described kind, very large vehicles, with a non-visible rear area can maneuver with safety.

[0004] The disadvantage in the described situation is, that during the carrying out of the maneuvering, with the help of the two rearview mirrors, and the back-up aid, the driver's attention is being given continually to one of the two rearview mirrors, or between two rearview mirrors and must then wander also to a display arranged on or in the instrument board. This stresses the concentration and also impairs the exactness of judgement regarding the images in the mirrors or in the back-up aid display. The latter is particularly significant, if very highly contrasting brightness conditions exist between the image in the rearview mirrors and that of the back-up aid display, since the eye always requires a certain elapsed time to adapt to a bright-dark, dark-bright change in the viewing field. Further, the image in the rearview mirror(s) and the display, as a rule, lie in different distances, so that the eye, in the continual change of view, requires also a certain accommodation time for this. All these factors add up to the point, that upon back-up maneuvering with the help of the rear view mirrors and the display of a back-up aid, a great deal of know-how and concentration are being expected from the driver during the operation.

[0005] Faced with this problem, the purpose of the invention is to create a rearview mirror, which enables the driver of a vehicle to accept, along with the information communicated to him by the rearview mirrors, additional information without having to take his eyes off of the rearview mirrors.

[0006] To achieve this purpose, the present invention proposes, in accord with claim 1, a rearview mirror, particular for motorized vehicles, with a mirror pane, wherein the mirror is thereby characterized, in that in the top view direction, behind the mirror pane, is placed at least one radiation emitting, display element, which radiates through the said mirror pane.

[0007] Within the scope of the present invention, there would be one radiation emitting display element located behind the mirror pane, whereby this display element would emit its radiation through the said mirror pane.

[0008] Mirror panes, for instance, such as are of chrome-glass, to a certain degree, are transparent for such radiation as enters through the back side of the mirror pane.

[0009] At the same time, the said mirror panes remain reflective and mirror-like, when seen from the front side. The present invention makes use of this, since it places at least one radiation emitting display element behind the said mirror pane. This display, associated with this element, for an observer in front of the mirror, lies, more or less in the mirror pane plane and the information transmitted by the display element appears through the mirror pane "in" the usual reflected image, which is reflected from the said mirror pane.

[0010] In this way, it is possible to place the emitting display element(s) of back-up aid facilities, in accord with the teachings of the present patent, behind the mirror pane. When this is done, then these display elements merge their corresponding information through the mirror pane, blending into the reflective image on the mirror pane. The observer then receives thus, at one glance, information from the mirror image on the mirror pane, as well as information from the display element(s). The view of the driver need no longer be divided between the mirror and a separate display apparatus. The driver's view need not wander back and forth to the instrument panel, but his attention remains, during the back-up maneuver, solely on the mirror. This is the result of all the collected data for the back-up operation being presented at one glance. More precise and fatigue-free driving becomes possible by these measures.

[0011] The display element can radiate in the spectrum of either visible or infrared light. In practice, the emission of light in the visible spectrum is used in the majority of cases, since, with such light, a direct optical display is possible. For certain application cases, an emission of infrared can be of interest, for instance, for information which is not visible for the naked eye, or coding between the vehicle and a stationary point for supervision and registration. In this connection, it should be mentioned, that the object of the present invention is directed toward bringing radiation emitting display elements in general behind the mirror pane.

[0012] A direct visual information transmission to the driver by means of these display elements is only a possible and an especially advantageous application of the concept of the invention. Found as advantageous in accord with a further embodiment, is a plurality of light radiating display elements assembled in groups behind the mirror pane. In this case it becomes possible, to transmit even more complex data, for instance, a decreasing spatial interval between the tail gate of the vehicle and an obstruction or target of maneuvering while backing up. Of possible consideration,

is, for instance, a longer series of display elements set next to each other, among which one or the another is either active or inactive, if the tail gate of the vehicle nears an obstruction or the target of back-up maneuvering. The method of function in this case is that as the approach comes to a minimal distance, either all display elements deactivate or cause a display light-up in the form of a figurative barrier. A further possibility in the presentation of information would be enabling a blinking display, the frequency of which is directly proportional to the distance to the obstruction or the target of the backing-up maneuvering.

[0013] Given preference are the LEDs serving in display elements, in particular high capacity LEDs. Preference is given because of small size, modest power demands, high life expectancy, freedom from sensitivity to vibration and impact, and availability in various dimensions and shapes. A further advantage is also obtained, when, in accord with a further embodiment, the LEDs are of varied colors. By this means, the data content, which can be transferred through the mirror pane, can still be amplified.

[0014] Instead of, or in addition to LEDs, the display elements can activate one or more "seven segment" displays. In this case, it is possible to display the intervening distance from the tail gate of the vehicle to the obstacle or target of the back-up maneuvering, in direct analog form, i.e. in meters or centimeters. Also other data, such as the outside temperature, the assured clear distance to the preceding vehicle on the road, a switching on of the mirror heating, a memory function for the mirror adjustment motor, turn signal blinkers, the presence of persons in the non-visible dead zone, all of which can be captured and subsequently converted into display.

[0015] Based on the fact, that display elements are arranged behind the mirror pane and must radiate through the said mirror pane, there arises the advantage, on the one hand, that the display image evolved from display element emission, appears practically directly on the already reflecting surface of the mirror. Furthermore, the now enclosed display elements are protected from weather and environmental hazards. However, there arises, due to the radiation through the mirror pane, a certain weakening of the displayed image which is observed by the driver. In unfavorable light situations, this can lead to a situation wherein the visual light projected into the mirror pane of the rearview mirror, cannot be read or deciphered, or is only poorly recognizable.

[0016] On this account, in accord with another embodiment of the present invention, the reflective coating of the surface area immediately in front of the display elements emanation is at least partially removed. This permits the emanated display to proceed from the display element to the visualizing surface with the least hindrance through the transparent or translucent material of the mirror pane. Thus the display is not weakened. In order to prevent that by this partial removal of the reflective coating, the rearview mirror, that is, its reflective layer, appears to be "perforated", in accord with yet another advantageous embodiment of the present invention, the removing of the reflective layer is carried out in the form of thin, incised lines, parallel to one another or in the form of small, individual dots. Again, filling an surface shape sized to conform to the emitting aperture of the display element, the above removing means are applied to the mirror front surface.

[0017] In particular then, when the removed surface of the mirror is in the form of thin, incised lines, parallel to one another or in the form of small, individual dots, this removing, or distancing, of the mirror coating from a certain observational distance, is essentially no longer visible and essentially does not impair the presentation of the mirror image. A further possibility, is to so abrade the reflective layer, that distinctive symbols or so-called pictograms, which then illuminate, when one or another of the several display elements behind said reflective layer are activated.

[0018] In order to prevent possible divergent radiation, or halo formations about the true point of light, or images, the back side of the mirror, with the exception of the transparent areas for visible light or radiation can be covered with, for instance, a lacquer coating.

[0019] The partial removing, or abrasion of the reflective layer can, for instance, be carried out by a precision laser, by an etching procedure, by sand blast abrasion, by incision of lines or by a masking done when the reflective mirror coating was applied.

[0020] The direction of radiation of the display elements can be at an angle either away or toward the observer, so that the resulting image in various directions appears differently intense or bright, and also clear or less clear, i.e. to the point of not being seen at all. The radiation direction of the display elements can be directed through lenses, which are ground into the material of the mirror pane or are fastened thereto.

[0021] Further details, aspects and advantages of the present invention arise from the following description of embodiments with the use of the drawing. There is shown in:

[0022] FIG. 1 a simplified, side sectional view through an rearview mirror in accord with the invention, with a display element placed behind the mirror pane,

[0023] FIG. 2 a front view of a mirror pane with an arrangement or possibilities for display elements and

[0024] FIG. 3 a sectional side view through a lens ground into the mirror pane.

[0025] A rear view mirror, designated in the drawing as a general presentation 2, exhibits the laminate construction as shown in the sectional view FIG. 1, with a carrier plate 4 and a mirror pane 6 fastened thereon. The rearview mirror 2, in the embodiment shown in FIG. 1, is designed as a so-called forward surface mirror, which is to say, the mirror pane 6 has the reflective coating or layer not on the surface in proximity to the carrier 4, but on the free exposed surface. An example of this kind of mirror pane 6 is a mirror of chrome-glass.

[0026] The carrier plate 4 serves for the mounting of at least one, or preferably a plurality of, display elements 8 located behind the mirror pane 6, thus being in the interior of the rearview mirror 2. In FIG. 1 the display element 8 is designed in the form of an LED 10. For the secure anchoring of said LED 10, the carrier plate 4 possesses a socket 12 which conforms to the outer contour of the LED 10, in which the LED 10 is inserted and, if necessary, is also held with adhesive. In the area of the socket 12, the carrier plate is opened so that the LED is allowed to lie directly behind the mirror pane 6. The electrical connecting members 14 and 16 of the LED 10 are soldered at a board 18, which has the necessary supply and control wiring. Preferably, the said board 18 is in the form of a so-called circuit board. The

board **18** can, for instance, be supported on the carrier plate **4**, as is indicated in **FIG. 1** by the dash-dot-dot line. In case of necessity, or if so desired, between the front side or the forward end of the LED **10** and the back side of the mirror pane **6**, a focusing lens can still be placed. This lens then takes care that light emitted from the LED **10** strikes the rear side of the reflective mirror layer **6** essentially in a vertical direction, so that less refractive and reflective error occurs and the amount of light available is used to its greatest extent. Further, such a focusing lens permits a bundling and thus an intensifying of the light emitted by the LED **10**, which light continues through the mirror pane **6**.

[0027] The direction of the radiation emitting display element can also proceed at an angle either to or from the observer, so that the image produced by the display element from various directions appears differently intense or bright, also clearer or less clearly, even to the point of not being seen at all. Thus other persons, i.e. passengers, are not disturbed. The direction of radiation of the radiation emitting display element can, in this respect, be directed through lenses, which lenses are either ground into the material of the mirror pane or fastened thereto.

[0028] Instead of the one-piece design of the socket **12** on the carrier plate **4**, this can be a separate component, which is clipped onto the said carrier plate **4** or affixed thereto by adhesive, or yet otherwise fastened.

[0029] Also, in the case of another embodiment of the radiation emitting display element, this too can be secured by adhesive directly on the back side of the mirror pane.

[0030] **FIG. 2** shows a view from the front on a surface section of the mirror pane **6** of the rearview mirror **2** in accord with the present invention. In the embodiment shown in **FIG. 2** are presented a total of three LEDs **10** and display elements **20a**, **20b** and **20c** which lie adjacent to one another. **FIG. 2** shows also the possibility, that instead of using behind the mirror pane **6** an LED or a pilot light, a so-called seven segment display **22** may be employed, which also projects its image through the material of the mirror pane **6**. Through the assembly of a plurality of LEDs and/or a plurality of seven segment displays, the presentation of complex information or data can be made on the surface of the mirror pane **6**. Amplification permits the additional effect, that different colored LEDs or display pilot lights can be used, particularly in the colors green, yellow and red.

[0031] Further, the display elements **8** can be grouped together in the surface of the mirror pane **6**, or otherwise arranged, in order to make certain information or displays even more noticeable.

[0032] Instead of light emitting display elements, that is, display elements which emit light in the visible range, for certain application cases—as explained already above—it can be of advantage to use display elements which emit in the infrared spectrum, that is, the so-called IR-diodes. For instance, the use of LEDs in the IR spectrum is of advantage if a camera is installed. Such a camera would be mounted externally on the vehicle and would monitor such areas in dead zones which cannot be seen by the driver. IR-diodes together with an IR responsive camera permit a monitoring or presentation of pictures without detriment to the immediate surroundings, that is, by glare. In this connection be advised to refer to the parallel German Patent with the title

“Rearview Mirror” (Patent Lawyer’s file number, ML0316). In the text therein contained, a particularly advantageous camera for this service is described. In the therein contained disclosures, reference is made in full in this instrument.

[0033] Based on the radiation passage emanating from the display element **8** and passing through the material of the mirror pane **6** and thereafter through the reflective mirror coating, a certain weakening of the emitted light, or other radiation, from the display element **8** occurs. Although this can be partly compensated for by the use of, for instance, high capacity LEDs, in accord with yet another preferred embodiment, the reflective coating of the mirror pane **6** in at least an area in front of the display element **8** can be partially removed.

[0034] **FIG. 2** demonstrates a total of five possibilities, as to how this mirror coating of the mirror pane **6** in front of the display element(s) **8** can be removed. In the case of the display element or the LED **20a**, the reflective mirror coating is in the form of very thin, incised lines, essentially closely aligned and parallel to one another. These lines **24** can run horizontally, diagonally or vertically and lie in front of the display elements **8** or the LED **20a**. Because of the removing of the mirror coating by said thin lines **24**, on the one hand, a clearly greater portion of the radiation emitted from the display element **8** can pass through to the outside, on the other hand, the reflective character of the mirror pane **6** will only be immaterially affected.

[0035] The same, or similar effects, can be achieved wherein the reflective layer is partially removed by a plurality of individual small dots **26**, as this is indicated in **FIG. 2** in the case of the LED **20c**.

[0036] A further possibility for the set-back of the reflective coating would be to partially remove this in the shape of one of the radiation emitting surfaces of the size corresponding surface **28**, of the display element. Since the size of the surface **28**, essentially represents only the size of the radiation emitting surface of the display element (LED **20b**), by this procedure, the surface of the mirror pane **6** likewise is only immaterially affected.

[0037] Also, in front of the seven segment display **22** or in front of a plurality of seven segment display, for instance lines **24** or dots **26** can be designed into the mirror reflective layer, in order to increase the transparency of the mirror pane, that is to say, the reflective coating on said mirror pane.

[0038] Further, the reflective coating can be partially removed in the form of symbols and pictograms. As an examples, we would name here a symbol **30** as an ice warning and a symbol **32** for the mirror heating in **FIG. 2**.

[0039] The design of the lines or the dots **24**, **26** and **28** can be made by a laser, by an etching procedure, by sand blasting, by scoring. The design can also be made by corresponding masking when the reflective coating is applied on the mirror pane **6**.

[0040] The display element(s) can be equipped with a common or separate acting dimmer function, in order to be able to adjust the current optimal or desired degree of brightness.

[0041] The direction of radiation of the radiation emitting display element can, upon requirement, be inclined away from an observer, or it can be directed toward this said

observer, so that the display element, appears differently intense or bright, or clear or less clear, even to the point of not being seen at all. Other persons thus, for instance, a passenger, need not be disturbed by said display. The radiation direction of the radiation emitting display element can be directed, in this matter, through lenses either ground into the material of the mirror pane or adhesively affixed to the same. **FIG. 3** shows an example of a ground lens **34**.

[0042] In order to prevent possible divergent radiation, or halo formations about the true point of light, or image emanations, the back side of the mirror **6**, with the exception of the transparent areas for visible light or radiation can be covered with, for instance, a lacquer coating. **FIG. 3** shows the arrangement with the lacquer coating **36** applied around the lens **34**. In the case of **FIG. 1**, the lacquer coating **36** was applied between the carrier plate **4** and the mirror pane **6** around the socket **12**. More exactly the lacquer was applied around the radiation emanation opening **38** defined by said socket.

[0043] Within the framework of the present invention, it is possible to merge data into the existing reflected images in the rearview mirror.

[0044] For instance, in the case of back-up aid, the driver, during back-up maneuvering, wherein he has to use his rearview mirror, receives simultaneously data from the back-up aid concerning the separation distance to an obstacle or to the target of the maneuvering, so the gaze of the driver need not wander back and forth continually between the rearview mirrors and the back-up display on the instrument board. Also other data may be presented, for instance the outside temperature, and the like. Furthermore, warning or advice signals can be blended into the surface of the rearview mirror **2**.

[0045] Since the display elements **8** lie behind the mirror pane **6** and the carrier plate **4**, they are guarded from contamination and environmental influences and reliably protected.

Claimed is:

1. A rearview mirror, in particular for motor vehicles, with a mirror pane (**6**), therein characterized, in that in the direction of a top view, behind the mirror pane (**6**) at least one radiation emitting display element (**8**) is placed, which emits radiation through the said mirror pane (**6**).

2. A rearview mirror in accord with claim 1, therein characterized, in that at least one display element (**8**) emits light in the visible range.

3. A rearview mirror in accord with claim 1, therein characterized, in that at least one display element (**8**) emits light in the infrared range.

4. A rearview mirror in accord with one of the claims 1 to 3, therein characterized, in that a plurality of radiation emitting display elements (**8**) is assembled in groups behind the mirror pane (**6**).

5. A rearview mirror in accord with one of the claims 1 to 4, therein characterized, in that the light emitting diodes (LEDs) (**10**, **20a**, **20b**, **20c**) of the radiation emitting display element (**8**) are especially high capacity LEDs.

6. A rearview mirror in accord with claim 5, therein characterized, in that the LEDs (**10**, **20a**, **20b**, **20c**) are of various colors.

7. A rearview mirror in accord with claim 1 or 2, therein characterized, in that the radiation emitting display element (**8**) is a seven segment display (**22**).

8. A rearview mirror in accord with one of the claims 1 to 7, therein characterized, in that the reflective mirror coating of the mirror pane (**6**) in an area in front of the display element (**8**) is at least partially removed.

9. A rearview mirror in accord with claim 8, therein characterized, in that the reflective mirror coating of the mirror pane (**6**) is removed in front of the display element (**8**) in the form of fine lines (**24**), essentially parallel to one another.

10. A rearview mirror in accord with claim 8, therein characterized, in that the reflective mirror coating of the mirror pane (**6**) is removed in front of the display element (**8**) in the form of individual small dots (**26**).

11. A rearview mirror in accord with claim 8, therein characterized, in that the reflective mirror coating of the mirror pane (**6**) is removed by dots (**26**) in front of the display element (**8**) in the form of a surface shape (**28**) essentially conforming to the size of the radiation emitting surface of the display element (**8**).

12. A rearview mirror in accord with claim 8, therein characterized, in that in that the reflective coating of the mirror pane (**6**) in front of the display element (**8**) is removed in the form a symbol or pictogram (**30**, **32**).

13. A rearview mirror in accord with one of the claims 8 to 12, therein characterized, in that the reflective coating is abraded by means of a laser.

14. A rearview mirror in accord with one of the claims 8 to 12, therein characterized, in that the reflective coating is abraded by means of an etching procedure.

15. A rearview mirror in accord with one of the claims 8 to 12, therein characterized, in that the reflective coating is abraded by means of a scoring procedure.

16. A rearview mirror in accord with one of the claims 8 to 12, therein characterized, in that the reflective coating is abraded by means of a sand blasting procedure.

17. A rearview mirror in accord with one of the claims 1 to 16, therein characterized, in that the side of the mirror pane (**6**) proximal to the radiation emitting display element (**8**), with the exception of those areas of the radiation emissions (**38**) is covered with a coating impenetrable by light or radiation.

18. A rearview mirror in accord with one of the claims 1 to 17, therein characterized, in that the direction of the radiation from the radiation emitting display element (**8**) can be either angularly inclined away from an observer, or angularly inclined toward said observer.

19. A rearview mirror in accord with claim 18, therein characterized, in that the radiation direction of the radiation emitting display element (**8**) is directed through a lens (**34**) ground into the material of the mirror pane (**6**) or affixed thereon.

* * * * *