

June 25, 1963

W. C. SHAW

3,095,208

SAFETY GUARD CONSTRUCTION FOR ICE SKATES

Filed Oct. 12, 1961

2 Sheets-Sheet 1

FIG. 2

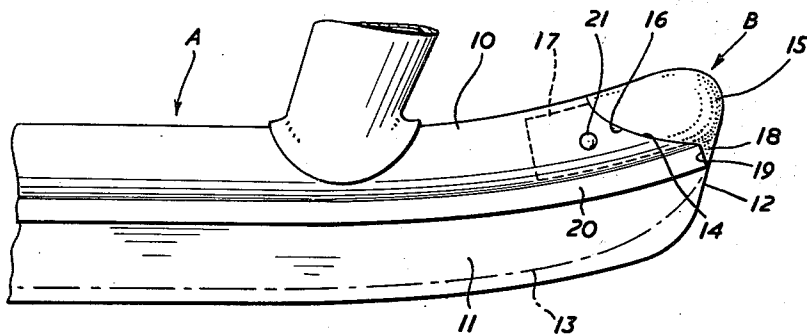

FIG. 4

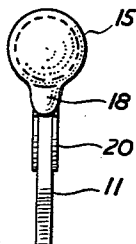

FIG. 3

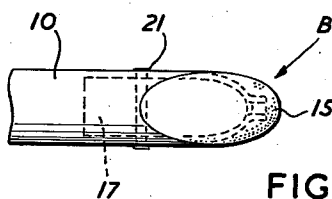
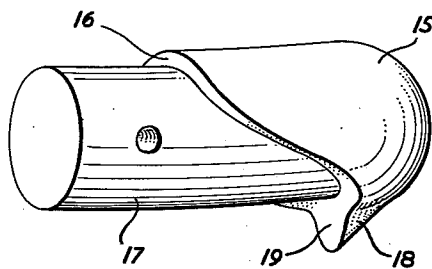

FIG. 1



INVENTOR  
WILLIAM C. SHAW

BY: *Fetherstonhaugh & Co.*  
ATTORNEYS

June 25, 1963

W. C. SHAW

3,095,208

SAFETY GUARD CONSTRUCTION FOR ICE SKATES

Filed Oct. 12, 1961

2 Sheets-Sheet 2

FIG. 6

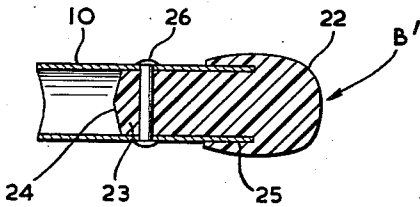
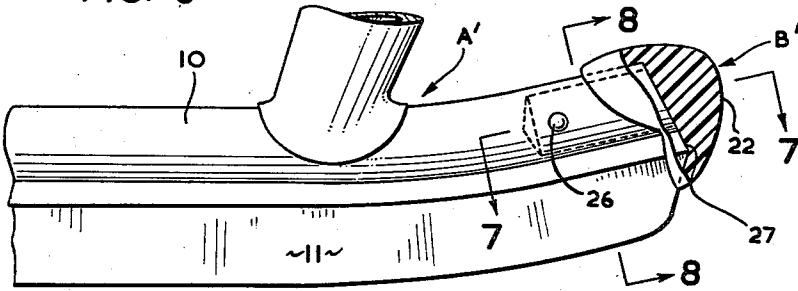

FIG. 7

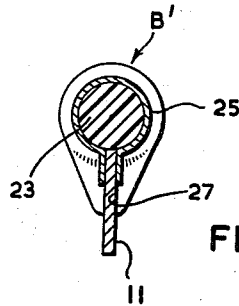

FIG. 8

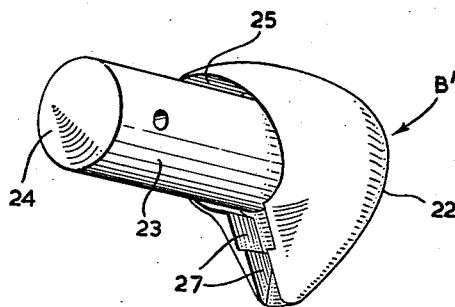

FIG. 5

INVENTOR  
WILLIAM C. SHAW

BY: *Fetherstonhaugh & Co*  
ATTORNEYS

1

3,095,208

**SAFETY GUARD CONSTRUCTION FOR  
ICE SKATES**

William C. Shaw, Streetsville, Ontario, Canada, assignor  
to Canada Cycle and Motor Company Limited, Weston,  
Ontario, Canada

Filed Oct. 12, 1961, Ser. No. 144,617

Claims priority, application Canada Dec. 19, 1960

4 Claims. (Cl. 280—11.17)

This invention relates to a safety guard construction for ice skates and in particular to a safety guard for tube bladed skates.

In most ice skates, and particularly in tube skates, the blade terminates in a free end. In the course of grinding the blade from time to time during use, the blade at the rear end becomes tapered down so that the free rear end of the blade becomes nearly pointed and is sharp so that it becomes dangerous, particularly in hockey games where the action is fast and rugged. The present invention seeks to avoid this dangerous condition of the skate by applying thereto a safety guard of blunt character such that regardless of the grinding of the blade and the tapering of the end thereof, the blunt guard projecting beyond the rear end of the blade will in effect provide a blunt bumper which will largely avoid cutting hockey players or people who accidentally might come into contact with the rear end of the skate blade during its use.

The invention generally comprises a safety guard in the form of a blunt bumper element formed of plastic or other suitable material and which incorporates a blunt toe and a shank of smaller cross-sectional area, said shank being adapted to be fitted and secured within the rear end of the skate tube so as to locate the toe on the end of the tube projecting beyond the end of the skate blade. Preferably, for greater security of mounting, the body of the safety guard is recessed in an area surrounding the inner end of the shank as to form a socket for receiving and surrounding an end portion of the tube of the skate and which socket preferably extends to form a narrow recess capable of receiving and surrounding a portion of the end of the skate blade. The invention, of course, includes as well the combination of a safety guard element with a tube skate wherein the rear end of the tube is fashioned to mate with the guard and thus mount the guard, suitable means being provided for securing the guard when so mounted.

The invention will be clearly understood by reference to the following detailed specification taken in conjunction with the accompanying drawings, wherein:

FIGURE 1 is a perspective view of the safety guard according to the present invention;

FIGURE 2 is a fragmentary side elevation of the rear portion of a tube skate showing the guard of the present invention mounted in position;

FIGURE 3 is a fragmentary view in top plan of the rear end of a skate blade structure showing the guard carried thereby;

FIGURE 4 is a rear elevation of the end of a skate blade showing the guard mounted in position.

FIGURE 5 is a perspective illustration of a modified safety guard;

FIGURE 6 is a fragmentary side elevation of the rear end of a tube skate showing the modified safety guard mounted and illustrated partly in section for clarity of reference.

FIGURE 7 is a longitudinal section taken substantially along the line 7—7 of FIGURE 6; and

FIGURE 8 is a transverse section taken substantially along the line 8—8 of FIGURE 6.

Referring to the drawings, A indicates the rear portion

2

of a tube skate blade structure which is made up of tube 10 of a conventional character which fixedly carries the skate blade 11 in well known manner and both of which terminate in a free end 12. In the course of sharpening the skates by hollow grinding of the blade, the blade gradually reduces in depth and most frequently is ground down to a greater extent towards the end so as to finally taper much in the manner of the dotted line 13 to virtually become a pointed end. This is dangerous and has resulted in many injuries by cuts and gashes when the end of the skate comes in contact with another person, which frequently happens in hockey games in particular.

In order to avoid this hazard, the present invention provides for a blunt end guard B which is designed to project rearwardly beyond the rear end of the blade structure of the skate whereby to constitute a blunt bumper guard so as to avoid cutting when contact is made with another person as above indicated. According to the invention, the rear end of the tube 10 carrying blade 11 is left open and is preferably cut or shaped in an upwardly receding curve 14. The safety guard, which may be formed of any suitable material, preferably plastic material capable of molding such as nylon or linear polyethylene, is made up of a blunt toe 15 of a diameter or girth greater than the cross-sectional diameter of the tube 10 and is preferably provided with a peripheral curved shoulder 16 designed to mate with the upwardly receding curve 14 of the rear end of the tube 10 so as to abut the edges thereof and in effect form a cover for said edges of the tube. These shoulders are formed between the toe and the integral shank 17 of the guard, which shank has a cross-sectional diameter approximating the internal diameter of the tube 10 so that it will fit snugly within the tube so as to mount the guard B firmly on the rear end of the skate blade structure. Preferably the toe is provided with the downwardly projecting tapered lug 18 formed with a shoulder 19 adapted to abut the upper rear end of the blade and to overlap the flanges 20 of the tube which secures the blade 13 thereto.

The shank 17 is firmly secured in the tube by any suitable means as by a tight friction fit between the inner surface of the tube and the outer surface of shank 17 or it may be secured by means of a suitable cement such as epoxy cement, particularly in the case of a plastic guard. Alternatively and preferably the shank is secured by means of a rivet 21 so that where for any reason the guard may become damaged it is easily replaced by filing the rivet, mounting a new guard and re-riveting.

In an alternative construction, as illustrated in FIGURES 5 to 8, the tube skate A' is designed to be fitted with the safety guard B', which incorporates the blunt toe 22 of a diameter or girth greater than the cross-sectional diameter of tube 10, and includes a cylindrical shank 23 projecting from the body in a direction opposed to the blunt toe 22, terminating in free end 24. The shank is formed of a diameter to fit the internal diameter of tube 10 snugly and the blunt toe, substantially larger, forms a substantial blunt bumper guard, all of which are characteristic of the guard illustrated in FIGURES 1 to 4. However, this construction varies from the structure shown in these previous figures by recessing the body as at 25 to form a socket of reasonable depth surrounding the base of the shank adjacent to its connection with the body, which socket extends radially below the shank to provide the continuing recessed portion 27. Consequently, when the shank 23 is projected into the open end of tube 10 of the skate, as shown in FIGURE 6, the socket 25 and its extension 27 are adapted respectively to encompass the rearward end of the tube 10 and a part of the rearward end of the blade 11 of the skate

in snug fitting relationship. This, therefore, provides for the encasement of the end of the tube and the end of the blade. The shank 23 is secured within the tube in a suitable manner and preferably similarly to the securement illustrated in FIGURE 2 of the drawings by a rivet 26, 5 illustrated in FIGURE 7, passing transversely through tube 10. However, securement could, of course, be achieved by a suitable adhesive or cement, such as epoxy cement, particularly in the case of a plastic guard. Notwithstanding the character of the securing means, how- 10 ever, it is noted that the provision of the socket 25, including its extension 27, not only serves efficiently to encase a portion of the end of the blade 11 but the fact that it snugly embraces a portion of the blade on each side thereof adds to the securement of the guard on the skate since it will resist any tendency of the guard to rotate 15 about the axis of the shank when subjected to certain types of impact and, in this manner, strain on the means of securement of the shank is avoided. In consequence, the guard will remain secure on the skate under varying conditions of usage.

From the foregoing it will be clearly understood that the guards B and B' as above described constitute a very simple one-piece element which is economic of manu- 25 facture and which, when mounted, will avoid the previous hazard of skate blades in a practical way. It is preferably formed from material which may be readily molded, i.e. plastic material as mentioned, but it is obvious, of course, that the invention is not limited to any particular material. 30

What I claim as my invention is:

1. A safety guard for tube bladed skates comprising a body incorporating a blunt toe element and a shank of smaller cross-sectional area, said shank being capable of securement in the rear end of the blade carrying tube of the skate to cause a portion of said toe element to project 35 beyond the rear end of said blade and tube, said body being recessed in an area surrounding the inner end of the shank as to form a socket for receiving and surrounding an end portion of the tube of the skate. 40

2. A safety guard for tube bladed skates as claimed in claim 1 in which said socket is extended to form a narrow recess capable of receiving and surrounding a portion of the end of the skate blade. 45

3. Safety guard means for tube bladed skates comprising in combination a guard body incorporating a blunt toe element and a shank of smaller cross-sectional area axially projecting therefrom as to provide a marginal shoulder at the junction of said shank and blunt toe element, a tube skate having the rear end of the tube open and carrying said shank therewithin, the rear end of said tube terminating in a surface complementary to and abutting said marginal shoulder, said shank being of a diameter substantially equal to the internal diameter of said tube, and means for securing said shank within said tube, said body being recessed inwardly in an area surrounding said shank up to said marginal shoulder, where- 15 by said guard receives and surrounds an end portion of the tube of the skate.

4. Safety guard means for tube bladed skates comprising in combination a guard body incorporating a blunt toe element and a shank of smaller cross-sectional area axially projecting therefrom as to provide a marginal 20 shoulder at the junction of said shank and blunt toe element, a tube skate having the rear end of the tube open and carrying said shank therewithin, the rear end of said tube terminating in a surface complementary to and abutting said marginal shoulder, said shank being of a diameter substantially equal to the internal diameter of said tube, and means for securing said shank within said tube, said marginal shoulder extending in a projection 25 below said shank as to butt a portion of the rear end of the skate blade, said body being recessed inwardly in an area surrounding said shank up to said marginal shoulder, whereby said guard receives and surrounds an end portion of the tube of the skate and a portion of the end of the skate blade. 30

#### References Cited in the file of this patent

##### UNITED STATES PATENTS

783,417	Bryant	Feb. 28, 1905
785,325	Nott	Mar. 21, 1905
1,142,855	Soty	June 15, 1915
1,646,843	Winslow	Oct. 25, 1927
1,771,755	Heath	July 29, 1930
2,348,475	Howard	May 9, 1944
2,466,475	Planert	Apr. 5, 1959
3,026,119	Bauer	Mar. 20, 1962