



(86) Date de dépôt PCT/PCT Filing Date: 2010/02/19
 (87) Date publication PCT/PCT Publication Date: 2010/08/26
 (85) Entrée phase nationale/National Entry: 2011/08/17
 (86) N° demande PCT/PCT Application No.: US 2010/000487
 (87) N° publication PCT/PCT Publication No.: 2010/096184
 (30) Priorités/Priorities: 2009/02/23 (US61/154,759);
 2009/08/11 (US29/341,672)

(51) Cl.Int./Int.Cl. *A01M 1/20* (2006.01)
 (71) Demandeur/Applicant:
 NUVENCO IP, LLC, US
 (72) Inventeur/Inventor:
 JAMES, DAVID, US
 (74) Agent: PERRY + CURRIER

(54) Titre : DISPOSITIF D'ERADICATION DE NUISIBLES
 (54) Title: PEST ERADICATION DEVICE

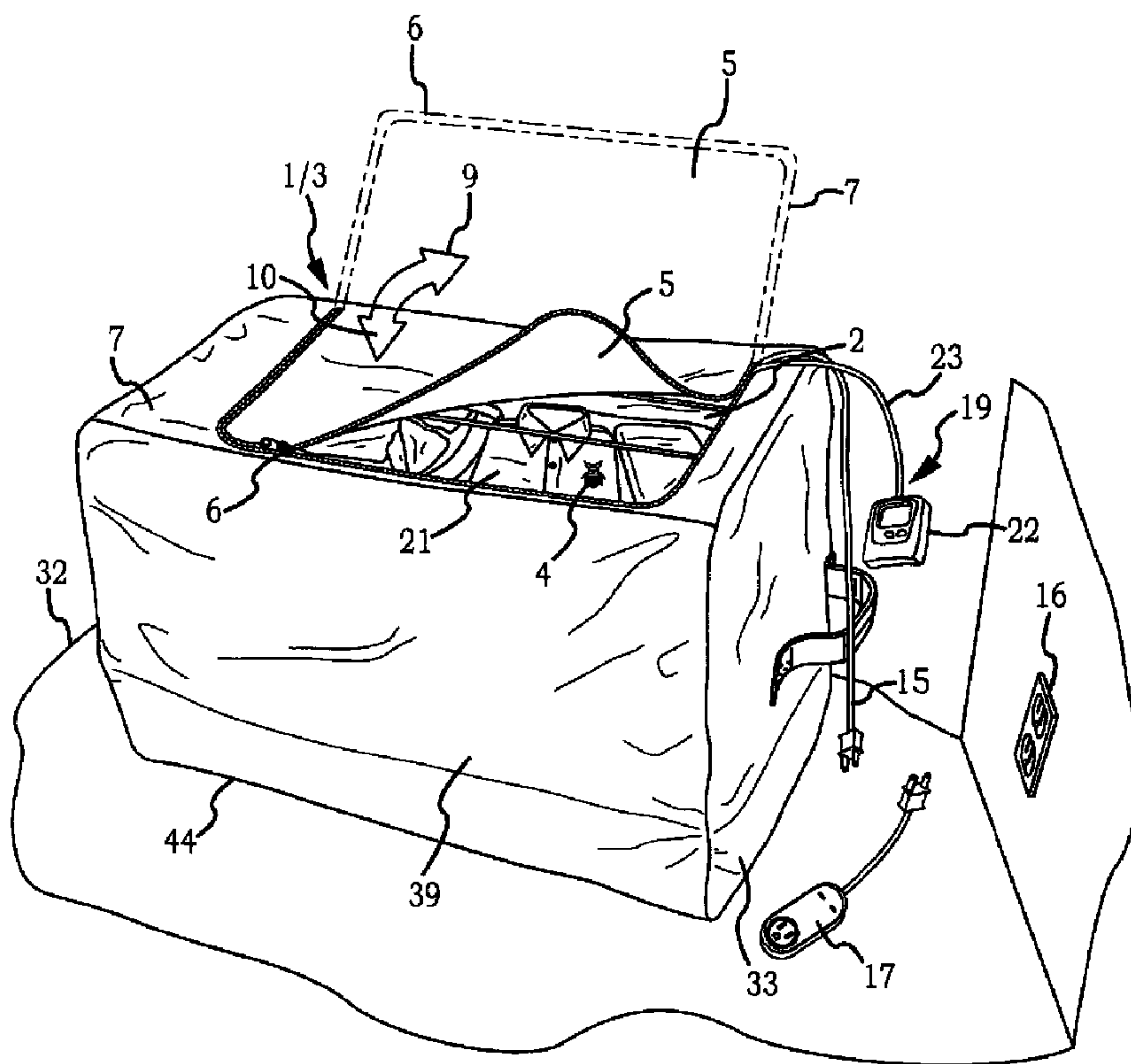

FIG. 1

(57) Abrégé/Abstract:

Generally, a structure for eradication of insects and method of treating materials infested with insects. Specifically, a support structure which engages a flexible enclosure to define an enclosed space in which heat can be controlled over a period of time to eradicate insects inside of the enclosed space.

(12) INTERNATIONAL APPLICATION PUBLISHED UNDER THE PATENT COOPERATION TREATY (PCT)

CORRECTED VERSION

(19) World Intellectual Property Organization
International Bureau



(43) International Publication Date
26 August 2010 (26.08.2010)

PCT

(10) International Publication Number
WO 2010/096184 A8

- | | |
|--|---|
| <p>(51) International Patent Classification:
<i>A01M 1/20</i> (2006.01)</p> <p>(21) International Application Number:
PCT/US2010/000487</p> <p>(22) International Filing Date:
19 February 2010 (19.02.2010)</p> <p>(25) Filing Language:
English</p> <p>(26) Publication Language:
English</p> <p>(30) Priority Data:
61/154,759 23 February 2009 (23.02.2009) US
29/341,672 11 August 2009 (11.08.2009) US</p> | <p>(63) Related by continuation (CON) or continuation-in-part (CIP) to earlier applications:
US 61/154,759 (CIP)
Filed on 23 February 2009 (23.02.2009)
US 29/341,672 (CIP)
Filed on 11 August 2009 (11.08.2009)</p> <p>(71) Applicant (for all designated States except US): NUVENCO, LLC [US/US]; 5605 Sunrise Court, Bellevue, CO 80512 (US).</p> <p>(72) Inventor; and
(75) Inventor/Applicant (for US only): JAMES, David [US/US]; 2242 Yorkshire Street, Fort Collins, CO 80526 (US).</p> <p>(74) Agent: MILES, Craig, R.; CR Miles P.C., 405 Mason Court, Suite 119, Fort Collins, CO 80524 (US).</p> |
|--|---|

[Continued on next page]

(54) Title: PEST ERADICATION DEVICE

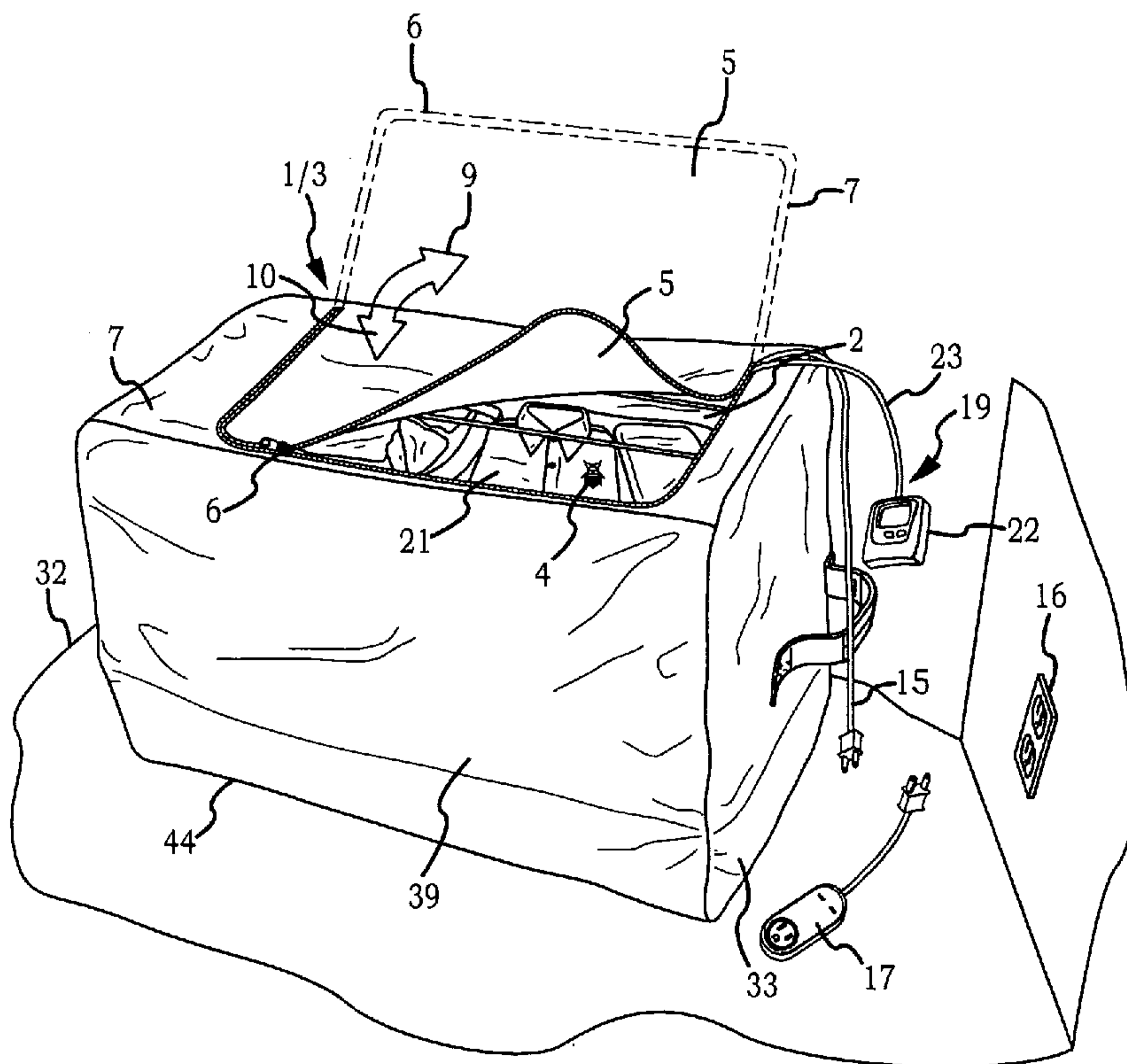

FIG. 1

[Continued on next page]

WO 2010/096184 A8

WO 2010/096184 A8 

- (81) Designated States** (*unless otherwise indicated, for every kind of national protection available*): AE, AG, AL, AM, AO, AT, AU, AZ, BA, BB, BG, BH, BR, BW, BY, BZ, CA, CH, CL, CN, CO, CR, CU, CZ, DE, DK, DM, DO, DZ, EC, EE, EG, ES, FI, GB, GD, GE, GH, GM, GT, HN, HR, HU, ID, IL, IN, IS, JP, KE, KG, KM, KN, KP, KR, KZ, LA, LC, LK, LR, LS, LT, LU, LY, MA, MD, ME, MG, MK, MN, MW, MX, MY, MZ, NA, NG, NI, NO, NZ, OM, PE, PG, PH, PL, PT, RO, RS, RU, SC, SD, SE, SG, SK, SL, SM, ST, SV, SY, TH, TJ, TM, TN, TR, TT, TZ, UA, UG, US, UZ, VC, VN, ZA, ZM, ZW.
- (84) Designated States** (*unless otherwise indicated, for every kind of regional protection available*): ARIPO (BW, GH, GM, KE, LS, MW, MZ, NA, SD, SL, SZ, TZ, UG, ZM, ZW), Eurasian (AM, AZ, BY, KG, KZ, MD, RU, TJ, TM), European (AT, BE, BG, CH, CY, CZ, DE, DK, EE, ES, FI, FR, GB, GR, HR, HU, IE, IS, IT, LT, LU, LV, MC, MK, MT, NL, NO, PL, PT, RO, SE, SI, SK, SM, TR), OAPI (BF, BJ, CF, CG, CI, CM, GA, GN, GQ, GW, ML, MR, NE, SN, TD, TG).
- (81)** — as to applicant's entitlement to apply for and be granted a patent (Rule 4.17(ii))
- as to the applicant's entitlement to claim the priority of the earlier application (Rule 4.17(iii))
- of inventorship (Rule 4.17(iv))
- Published:**
- with international search report (Art. 21(3))
- with amended claims (Art. 19(1))
- (88) Date of publication of the international search report:**
18 November 2010
- Date of publication of the amended claims:** 23 December 2010
- (48) Date of publication of this corrected version:**
28 April 2011
- (15) Information about Correction:**
see Notice of 28 April 2011

Declarations under Rule 4.17:

(57) Abstract: Generally, a structure for eradication of insects and method of treating materials infested with insects. Specifically, a support structure which engages a flexible enclosure to define an enclosed space in which heat can be controlled over a period of time to eradicate insects inside of the enclosed space.

PEST ERADICATION DEVICE

This International Patent Cooperation Treaty Patent Application claims the benefit of United States Provisional Patent Application No. 61/154,759, filed February 23, 2009 and United State Design Patent Application No. 29/341,672, each hereby incorporated by reference herein.

I. TECHNICAL FIELD

Generally, a structure for eradication of insects and method of treating materials infested with insects. Specifically, a support structure which engages a flexible enclosure to define an enclosed space in which heat can be controlled over a period of time to eradicate insects inside of the enclosed space.

II. BACKGROUND

Insect damage is common consumer problem related to clothing and other types of material. Insect damage to textiles in the United States is estimated at \$200 million annually. Fabric pests are making a comeback because most of the residual insecticides formerly used in their control such as *dieldrin* and DDT have been banned. Accordingly, as people travel there is a growing incidence of insect infestation of garments transported in luggage. For example, bed bugs can be found in any hotel, motel, home, or other accommodation regardless of the sanitation conditions. During the day nocturnal insects disappear in crevices associated with mattresses, box springs, sheets, upholstery, garments, clothes, pillows, towels, or the like. Even when these materials are examined, it is common for these insects to be packed and transported in luggage.

Presently, conventional remedies appear to be limited to unpacking transported materials and examining them in a remote location such as the garage or utility room prior to introducing the transported materials into a residence area with treatment of infested materials by dry cleaning, fumigation, or the like, to kill infestations of insects.

III. DISCLOSURE OF INVENTION

Accordingly, a broad object of the invention can be to provide a structure in which infested materials can be located for heat treatment at a temperature over a period of time lethal to the insects whether in the adult or other life stages prior to being transported from or into living areas of residences.

Another broad object of the invention can be to provide the structure in a constructional form which allows the collapse into a reduced volume for ready transportation as luggage or for storage in an remote location outside of the living area of hotel, motel, or other residence, the structure being readily erected to provide an operational volume in which materials can be located for heat treatment to kill insects.

Naturally, further objects of the invention are disclosed throughout other areas of the specification and drawings.

IV. BRIEF DESCRIPTION OF THE DRAWINGS

Figure 1 is a perspective view of a particular embodiment of the invention.

Figure 2 is a top view of a particular embodiment of the invention.

Figure 3 is an end view of a particular embodiment of the invention.

Figure 4 is a side view of a particular embodiment of the invention.

Figure 5 is a perspective view of a framework and heater having a location inside of a flexible enclosure (shown in broken line) of a particular embodiment of the invention.

Figure 6 is a top view of a framework and heater having a location inside of a flexible enclosure (shown in broken line) of a particular embodiment of the invention.

Figure 7 is a first end view of a framework and heater having a location inside of a flexible enclosure (shown in broken line) of a particular embodiment of the invention.

Figure 8 is a side view of a framework and heater having a location inside of a flexible enclosure (shown in broken line) of a particular embodiment of the invention.

Figure 9 is a second end view of a framework and heater having a location inside of a flexible enclosure (shown in broken line) of a particular embodiment of the invention.

Figure 10 is a perspective view of an embodiment of the invention in the reduced volume condition.

V. MODE(S) FOR CARRYING OUT THE INVENTION

Generally, a structure for eradication of insects and method of treating materials infested with insects. Specifically, a support structure which engages a flexible enclosure to define an enclosed space in which heat can be controlled over a period of time to eradicate insects inside of the enclosed space.

Referring primarily to Figures 1-4, embodiments of the invention provide a flexible enclosure (1). While the flexible enclosure (1) shown in Figures 1-4 has a generally rectangular external configuration and defines a generally rectangular enclosed space (2); the invention is not so limited and the flexible enclosure (1) can be configured to define an enclosed space (2) which can be tubular, a rectangular prism, a cube, pyramid, or the like.

The flexible enclosure (1) can be produced from any one or more of a variety of flexible material(s)(3). The constructional form of the flexible material (3) can be a single layer, or two layers, or a plurality of layers which can be slidably engaged or bonded together depending on the application. However, because insects (4) can readily travel on the surface of woven materials or on the surface of materials sufficiently textured or roughened, certain embodiments of the invention provide a flexible material (3) having an internal surface (5) sufficiently smooth to prevent, reduce, or impede travel of insects (4) to prevent egress through a releasably sealable opening (6) or other opening in the flexible enclosure (1). As one non-limiting example, the external surface (7) of the flexible enclosure (1) can provide a woven fabric of any of a numerous and wide variety of fibers such as cotton, nylon, rayon, polypropylene, carbon filaments, or the like. Because the external surface (7) of the flexible enclosure (1) does not come in contact with insects (4) placed within the enclosed space (2) of the flexible enclosure, any manner of external surface (7) texture can be utilized including a smooth external surface, if desired. The internal surface (5) of the flexible enclosure (1) can be provided by a plastic sheet or plastic film material such as polycarbonate, polyester, polyethylene, or the like, further compatible with the method of using the flexible enclosure (1) for the eradication of insects (4), as further described below.

Now referring primarily to Figures 1 and 2, the flexible enclosure (1) can further include a releasably sealable opening (6) which operates between an open condition (9) which allows access to the enclosed space (2) of the flexible enclosure (1) and a closed condition (10) in which the opening (6) seals by way of mateable parts such as the interdigitable teeth of a zipper as shown in Figures 1-4 or mateable engagement of a hook material to a loop material such as VELCRO; although the invention is not so limited, and any constructional form of mateable parts which sufficiently sealably mate to allow the enclosed space (2) of the flexible enclosure (1) to be temperature controlled, as further described below, may be utilized.

Now referring primarily to Figures 5-9 which show the flexible enclosure (1) in broken lines, embodiments of the invention further can further include a heater (11) which generates an amount of heat (12) captured within the enclosed space (2) of the flexible enclosure (1) to provide within the enclosed space (2) a temperature (14) over a period of time (13) lethal to a one or more species of insect (4). As a non-limiting example, the heater (11) can be selected to generate sufficient heat (12) to continuously maintain the temperature (14) within the enclosed space (2) of the flexible enclosure (2) in a range of between about 110° F and about 160° F for a period of time (13) between about five minutes and about 480 minutes. With respect to the range of temperature (14), different species of insect (4) have different tolerance to heat (12) over a period of time (13). Accordingly, the heater (11) can be selected or controlled to produce the amount of heat (12) to maintain a temperature (14) over a period of time (13) lethal to the species of insect (4). Alternately, it is believed that no life stage of an insect (4) can survive at a temperature over about 130° F for a period of 240 minutes. Accordingly, the heater (11) can be selected or controlled to produce an amount of heat (12) to raise the temperature within the enclosed space (2) of the flexible enclosure (1) to about 130° F for a period of time (13) of 240 minutes. However, lesser temperature (14) of about 113 ° F over a period of time (13) may be lethal to certain species of insects (4) such as bed bugs and greater temperatures of about 160° F may reduce the period of time (13) to kill insects (4) within the enclosed space (2) of the flexible enclosure (1). Accordingly, embodiments of the invention can balance the temperature (14) achieved within the enclosed space (2) of the flexible enclosure (1) with the period of time (13) depending on the application, with

embodiments of the invention represented by an increase in temperature (14) within the enclosed space (2) in increments of 2 ° F over the temperature range of 110° F and 160° F and represented by an increase in the period of time (13) in increments of five minutes over the time period of five minutes and 480 minutes in the various permutations and combinations. Temperature (14) and the period of time (13) can also be adjusted to allow the entirety of an amount of heat treatable material (21) having a location within the enclosed space (2) to achieve a temperature (14) lethal to insects (4), such insects (4) on or within heat treatable material (21) can be killed. As to the particular non-limiting embodiment of the invention shown in Figures 5-9, a 500 watt 120 volt heater (11) can be suitable to generate a sufficient amount of heat (12) to achieve temperatures (14) over a period of time (13) within the enclosed space (2), as above-described, sufficient to kill insects (4) inside of the flexible enclosure (1).

As to particular embodiments of the invention, the heater (11) which generates the amount of heat (12) captured within the enclosed space (2) of the flexible enclosure (1) can be located within the enclosed space (2) of the flexible enclosure (1) as shown in Figures 5-9; however, the invention is not so limited, and other particular embodiments of the invention can locate the heater (11) outside of the flexible enclosure (1) with the heat (12) generated by the heater (11) conveyed from outside of the flexible enclosure (1) to within the enclosed space (2) of the flexible enclosure (1) by direct engagement of the heater (11) to the external surface (7) of the flexible enclosure (1), embedded engagement of the heater (11) between layer of the flexible material (3) or by a conduit fluidically coupled between the heater (11) and the enclosed space (2) of the flexible enclosure (1), or the like. As shown primarily in Figures 1 and 5, embodiments of the invention in which the heater (11) has a location within the enclosed space (2) of the flexible enclosure (1), a power cord (15) for the heater (11) can pass through a part of the releasably sealable opening (6) for coupling to a power source (16).

Again referring primarily to Figures 1 and 5, embodiments of the invention can further include a timer (17) which electrically couples the heater (11) to the power source (16) for a period of time (13) in the range above described. Depending on the application, the period of time (13) can be selectably adjusted by use of the timer (17) to deliver power (18) from the power source (16) for a period of time between 5 minutes and 120 minutes

(or longer if desired, for example 8 hours). As a non-limiting example, the timer (17) can be selectably adjusted to deliver power (18) to the heater (11) for a period of time (13) of 120 minutes. A timer (17) suitable for use with particular embodiments of the invention can be a digital timer (17) obtained from Best Corporation, Fort Wayne, Indiana.

Again referring primarily to Figures 1 and 5, embodiments of the invention can further include a thermometer (19) having temperature sensor (20) which can be located within the enclosed space (2)(or within an amount of heat treatable material (21) located within the enclosed space (2)) of the flexible enclosure (1) and a viewable temperature indicator (22) which can be located outside of the flexible enclosure (1). As shown in Figure 1, the temperature sensor (20) can be coupled to the viewable temperature indicator (22) by a sensor wire (23) which can pass through a part of the releasably sealable opening (6)(or other aperture communicating between internal surface (5) of the flexible material (3) and the external surface (7) of the flexible material (3)) in the closed condition (10). A thermometer (19) suitable for use with embodiments of the invention can be a model TX 5020 available from Timex, Edison, New Jersey.

Now referring primarily to Figures 5-9, particular embodiments of the invention can further provide a framework (24) which supports the flexible material (3) of flexible enclosure (1) to define the enclosed space (2) within the flexible enclosure (1). As to certain embodiments of the invention, the framework (24) can be provide a fixed support structure (25) (does not collapse), while as to other embodiments of the invention, the framework can provided collapsible support structure (25) which operates between a collapsed condition (26)(see for example Figure 10) and an erect condition (27)(see for example Figure 5) to correspondingly provide a reduced volume (28)(see for example Figure 10) and an operational volume (29)(see for example Figure 1) of the flexible enclosure (1). While the embodiments of the invention shown in Figures 5-9 show the framework (24) located within the flexible enclosure (1), the invention is not so limited, and embodiments of the invention can provide the framework (24) supportingly engaged to the external surface (7) of the flexible enclosure (1) or disposed between the layers of the flexible material (3).

As to fixed embodiments of the invention, the framework (24) can provide a fixed support structure (25) having a first end frame (30) and second end frame (31) configured to supportingly engage and define the configuration of an opposed first end (32) and second end (33) of the flexible enclosure (1). The first and second end frames (30)(31) can for example be configured from metal rod (for example, between one-eighth inch diameter and one-quarter inch diameter) which can be bent to provide a wire end frame (34) defining within an open area (35) as shown for example in Figure 5. The first and second end frames (30) can be held a distance apart by corresponding side frames (36)(37) or a top frame (38) which supportingly engage and define the configuration of the opposed first and second sides (39)(40) of the flexible enclosure (1). The first and second side frames (36)(37) can be similarly constructed from metal rod bent to provide a wire frames (34) defining within an open area (35)

Alternately, as shown in Figures 5-9, fixed embodiments of the invention can provide a support structure (25) including a perforated platform (41)(although the perforated platform (41) can be provided separate from the support structure) to which the first and second end frames (30)(31) can be joined proximate opposed platform ends (42)(43). As shown for example in Figure 5, the perforated platform (41) can be generally rectangular in configuration and located within the enclosed space (2) of the flexible enclosure (1) in generally horizontal relation to the bottom (44) of the flexible enclosure (1). The first and second end frames (30)(31) can each comprise a wire frame (34) having a pair of generally linear members (45)(46) each having a first member end (47) fixedly coupled to opposed platform sides (48)(49) proximate the end (42)(43) of the perforated platform (41) and a second member end (51) correspondingly connected to opposed ends of a cross member (52). The first and second end frames (30)(31) coupled to the perforated platform (41) supportingly engage the flexible enclosure (1) to provide an operational volume (29) of generally rectangular volume. While Figures 5 and 6 show the perforated platform (41) as being assembled from a plurality of metal rods (53) each spaced a distance apart between the opposed sides (48)(49) of the perforated platform (41); the invention is not so limited, and the perforated platform (41) can be produced from pressed sheet material having a plurality of perforations or slots communicating between the surfaces of the sheet material for the purpose of allowing the heat (12) to circulate through the perforations, slots, or spaces of the perforated platform (41). As to

certain embodiments of the invention the perforated platform (41) can be located a distance from the bottom (44) of the flexible enclosure (2) by one or more vertical support members or legs (54). As shown in non-limiting example of Figure 5, the perforated platform (41) is located at a height above the bottom (44) of the flexible enclosure (2) by a generally vertical support member (54) proximate each corner of the perforated platform (41). Understandably, as to certain embodiments of the invention the platforms without perforations can be utilized.

Certain embodiments of the invention can provide a collapsible support structure (25) which operates between a collapsed condition (26) and an erect condition (27). One non-limiting example of a collapsible support frame (25) is shown by Figure 5, which includes the above described first and second end frames (30)(31) each including a pair of substantially linear members (45)(46) each having the first end (47) rotatably coupled to opposed platform sides (48)(49) proximate an end (42)(43) of said perforated platform (41) and each having a second end (51) correspondingly connected to opposed ends of a cross member (52). Each of the first and second end frames (30)(31) can rotate between a collapsed condition (26) having generally horizontal orientation in relation to the bottom (44) and an erect condition (27) generally vertical in orientation to the bottom (44) to correspondingly provide the reduced volume (28) and operation volume (29) of the flexible enclosure (2). Understandably, other configurations of a collapsible support structure (25) can be utilized to engage the flexible material (3) to provide a flexible enclosure (2) having a reduced volume (28) and an operational volume (29).

Now referring primarily to Figures 5-9, embodiments of the invention can further include an amount heat treatable material (21). For the purposes of this invention the term "heat treatable material" can be any material which can be removably located inside of the flexible enclosure (2) in the operational volume (29) and heated to a temperature (14) for a period of time (13) sufficient to kill insects (4), As a non-limiting example, within the temperature (14) range of about 110°F and about 160 °F within a period of time of about 5 minutes and about 480 minutes, a further described above. Heat treatable material (21) can further include material having attached, containing, or infested with, insects (4) regardless of the life stage.

Now referring primarily to Figures 1-4 which show the operational volume (29) of the flexible enclosure. Certain embodiments of the flexible enclosure in the operational volume (29) and in the reduced volume (28) can have external dimensions compatible with carrying embodiments of the structure for killing insects (4) by hand. An advantage of the structure for killing insects (4) can be portability which allows the structure for killing insects (4) to be transported in similar fashion to luggage for utilization while traveling to kill insects such as bed bugs in a hotel or motel room or other similar accommodation preventing transport of insects (4) from location to location.

For the purposes of this invention, the term "insect" includes all insects and without limitation to the forgoing insects such as bed bugs, powder post beetles, moths, roaches, termites, fleas, wasps, bees, cicadas, ants, lice, head lice, mites, grain beetles, flour beetles, fire ants, mosquitoes, leafhoppers, plant hoppers, ticks, flies, or the like, and can further include non-insect species such as spiders, ticks, centipedes, or the like, and including the adult form or any other form of the insect including but not limited to: eggs, larvae, pupae, cocoons, chrysalides, or any other life stage or life form of an insect, and can further include other pest organisms as to which the temperature and time periods described herein would be lethal.

A non-limiting example of a method of using the structure for killing insects can include a step of providing a flexible enclosure (1) having a releasably sealable opening (6) which operates between an open condition (9) and a closed condition (10), the flexible enclosure (1) having an external surface (7) and an internal surface (5), the internal surface (5) sufficiently smooth to prevent egress of said insects (4) through said releasably sealable opening (6). Another step of the method includes coupling a heater (11) to the flexible enclosure (1), the heater (11) capable of generating an amount of heat (12) within said flexible enclosure (1) to provide a temperature (14) over a period of time (13) lethal to said insects (4). The method includes the further step of locating heat treatable materials (21) infested with insects (4) within the enclosed space (inside) of the flexible enclosure (1). The method can further include the steps of establishing the releasably sealable opening (6) in the closed condition (10), and operating the heater (11) to achieve a temperature (14) over a period of time (13) inside of the flexible enclosure (1) lethal to said insects (4). The method can further include the step of establishing said temperature

within said flexible enclosure within a range of about 110°F and about 160°F and can further include the step of allowing elapse of a period of time within a range of about 5 minutes and about 480 minutes to treat heat treatable material within the enclosed space (2) of the flexible enclosure (1). The method can further include the steps of sensing temperature inside of the flexible enclosure (1) and indicating the temperature (13) on a temperature indicator (22) located outside of the flexible enclosure (1) which validates that the enclosed space (2) within the flexible enclosure (1)(or the heat treatable material (21) located within enclosed space (2)) has achieved a temperature (13) lethal to insects (4).

As to certain embodiments of the invention, the method can further include the steps of operating an enclosure support structure (25) between a collapsed condition (26) and an erect condition (27) to correspondingly provide a reduced volume (28) and operational volume (29) of the flexible enclosure (1). The method can further include the steps of providing a perforated platform (41) having proximate opposed ends (42)(43) a pair of substantially linear members (45)(46) each having a first end (47) rotatably coupled to opposed sides (48)(49) of the perforated shelf (41) and each having second end (51) correspondingly connected to opposed ends of a cross member (52) to provide the enclosure support structure (25). The method can further include the steps of configuring the perforated platform (41) in substantially rectangular configuration and locating the substantially rectangular configuration of the perforated platform (41) inside of the flexible enclosure (1) in generally horizontal relation to the bottom side (44) of the flexible enclosure (1) and configuring the first and second end frames (30)(310) of the enclosure support (25) in a substantially rectangular configuration which in the erect condition (27) locates inside of the flexible enclosure (1) in substantially vertical relation to the bottom (44) of the flexible enclosure (1) to define a generally rectangular operational volume (29) of the flexible enclosure (1).

Now referring primarily to Figure 10, as to certain embodiments of the invention, the method can further include the step of providing the reduced volume (28) of said flexible enclosure (1) in dimensional relations which allows a person to carry the flexible enclosure (1). As a non-limiting example, the flexible enclosure (1) in the operational volume (29) can have external dimensions of about 40 inches in length and about 18 inches in width with a height of about 24 inches and in the reduced volume (28) can have

external dimensions of about 40 inches in length and about 18 inches in width and about 10 inches in height; however, the invention is not so limited and depending upon the embodiment of the collapsible support structure (25) the external dimensions could be further reduced to facilitate portability or carrying by a single person.

As can be easily understood from the foregoing, the basic concepts of the present invention may be embodied in a variety of ways. The invention involves numerous and varied embodiments of a insect eradication structure and methods of treating materials infested with insects.

As such, the particular embodiments or elements of the invention disclosed by the description or shown in the figures or tables accompanying this application are not intended to be limiting, but rather exemplary of the numerous and varied embodiments generically encompassed by the invention or equivalents encompassed with respect to any particular element thereof. In addition, the specific description of a single embodiment or element of the invention may not explicitly describe all embodiments or elements possible; many alternatives are implicitly disclosed by the description and figures.

It should be understood that each element of an apparatus or each step of a method may be described by an apparatus term or method term. Such terms can be substituted where desired to make explicit the implicitly broad coverage to which this invention is entitled. As but one example, it should be understood that all steps of a method may be disclosed as an action, a means for taking that action, or as an element which causes that action. Similarly, each element of an apparatus may be disclosed as the physical element or the action which that physical element facilitates. As but one example, the disclosure of a "flexible enclosure" should be understood to encompass disclosure of the act of "flexibly enclosing" -- whether explicitly discussed or not -- and, conversely, were there effectively disclosure of the act of "flexibly enclosing", such a disclosure should be understood to encompass disclosure of a "flexible enclosure" and even a "means for flexibly enclosing." Such alternative terms for each element or step are to be understood to be explicitly included in the description.

In addition, as to each term used it should be understood that unless its utilization in this application is inconsistent with such interpretation, common dictionary definitions should be understood to included in the description for each term as contained in the Random House Webster's Unabridged Dictionary, second edition, each definition hereby incorporated by reference.

Thus, the applicant(s) should be understood to claim at least: i) each of the insect eradication structures herein disclosed and described, ii) the related methods disclosed and described, iii) similar, equivalent, and even implicit variations of each of these devices and methods, iv) those alternative embodiments which accomplish each of the functions shown, disclosed, or described, v) those alternative designs and methods which accomplish each of the functions shown as are implicit to accomplish that which is disclosed and described, vi) each feature, component, and step shown as separate and independent inventions, vii) the applications enhanced by the various systems or components disclosed, viii) the resulting products produced by such systems or components, ix) methods and apparatuses substantially as described hereinbefore and with reference to any of the accompanying examples, x) the various combinations and permutations of each of the previous elements disclosed.

The claims set forth in this specification, if any, are hereby incorporated by reference as part of this description of the invention, and the applicant expressly reserves the right to use all of or a portion of such incorporated content of such claims as additional description to support any of or all of the claims or any element or component thereof, and the applicant further expressly reserves the right to move any portion of or all of the incorporated content of such claims or any element or component thereof from the description into the claims or vice-versa as necessary to define the matter for which protection is sought by this application or by any subsequent application or continuation, division, or continuation-in-part application thereof, or to obtain any benefit of, reduction in fees pursuant to, or to comply with the patent laws, rules, or regulations of any country or treaty, and such content incorporated by reference shall survive during the entire pendency of this application including any subsequent continuation, division, or continuation-in-part application thereof or any reissue or extension thereon.

The claims set forth below are intended to describe the metes and bounds of a limited number of the preferred embodiments of the invention and are not to be construed as the broadest embodiment of the invention or a complete listing of embodiments of the invention that may be claimed. The applicant does not waive any right to develop further claims based upon the description set forth above as a part of any continuation, division, or continuation-in-part, or similar application.

The background section of this patent application provides a statement of the field of endeavor to which the invention pertains. This section may also incorporate or contain paraphrasing of certain United States or foreign patents, patent applications, publications, or subject matter of the claimed invention useful in relating information, problems, or concerns about the state of technology to which the invention is drawn toward. It is not intended that any United States patent, patent application, publication, statement or other information cited or incorporated herein be interpreted, construed or deemed to be admitted as prior art with respect to the invention.

All numeric values herein are assumed to be modified by the term "about", whether or not explicitly indicated. For the purposes of the present invention, ranges may be expressed herein as from "about" one particular value to "about" another particular value. When such a range is expressed, another embodiment includes from the one particular value to the other particular value. Similarly, when values are expressed as approximations, by use of the antecedent "about," it will be understood that the particular value forms another embodiment. It will be further understood that the endpoints of each of the ranges are significant both in relation to the other endpoint, and independently of the other endpoint. Unless otherwise expressly stated, embodiments of the invention represented by increase or a decrease in the numeric value from an end point or both end points within a range in increments of five percent.

Moreover, for the purposes of the present invention, the term "a" or "an" entity refers to one or more of that entity; for example, "a flexible enclosure" refers to one or more of those enclosures. As such, the terms "a" or "an", "one or more" and "at least one" can be used interchangeably herein.

AMENDED CLAIMS

received by the International Bureau on 15 November 2010 (15.11.2010).

1. A structure for killing insects, comprising:
 - a) a flexible enclosure having a releasably sealable opening which operates
5 between an open condition and a closed condition, said flexible enclosure having an external surface and an internal surface, said internal surface sufficiently smooth to prevent egress of said insects through said releasably sealable opening; and
 - b) a heater which generates an amount of heat captured within said flexible enclosure to provide a temperature over a period of time lethal to said insects.
10
2. The structure for killing insects of claim 1, wherein said temperature within said flexible enclosure occurs within a range of about 110°F and about 160 °F.
3. The structure for killing insects of claim 2, wherein said period of time occurs within
15 a range of about 5 minutes and about 480 minutes.
4. The structure for killing insects of claim 3, wherein said insects are selected from the group consisting of: bed bugs, powder post beetles, moths, roaches, termites, fleas, wasps, bees, cicadas, ants, lice, head lice, mites, grain beetles, flour beetles, fire ants, mosquitoes,
20 leafhoppers, plant hoppers, ticks, and flies.
5. The structure for killing insects of claim 4, further comprising a thermometer having temperature sensor having a location inside of said flexible enclosure and a viewable temperature indicator having a location outside of said flexible enclosure.
25
6. The structure for killing insects of claim 5, further comprising an amount of heat treatable material within said flexible enclosure.
7. The structure for killing insects of claim 6, wherein said heater has a location inside of
30 said flexible enclosure.
8. The structure for killing insects of claim 7, further comprising a framework which has a location inside of said flexible enclosure, said framework comprising a collapsible support

structure which operates between a collapsed condition and an erect condition to correspondingly provide a reduced volume and operational volume of said flexible enclosure.

5 9. The structure for killing insects of claim 8, further providing a perforated platform which has a location inside of said flexible enclosure configured to receive said heat treatable material.

10 10. The structure for killing insects of claim 9, wherein proximate each of the opposed ends of said perforated platform said enclosure support structure includes a pair of substantially linear members each having a first end rotatably coupled to opposed sides of said perforated platform and each having a second end correspondingly connected to opposed ends of a cross member.

15 11. The structure for killing insects of claim 10, wherein said perforated platform has a substantially rectangular configuration which locates inside of said flexible enclosure in substantially horizontal relation to said bottom side, and wherein said enclosure support structure in the erect condition has a substantially rectangular configuration which locates inside of said flexible enclosure in substantially vertical relation to said bottom to define a rectangular operational volume within said flexible enclosure.

20

12. The structure for killing insects of claim 11, wherein said reduced volume of said flexible enclosure has dimensional relations which allow a person to carry said reduced volume of said flexible enclosure.

25 13. The structure for killing insects of claim 12, wherein said amount of heat treatable material has an infestation of insects.

14. A method of killing insects in a structure, comprising the steps of:
a) providing a flexible enclosure having a releasably sealable opening which
30 operates between an open condition and a closed condition, said flexible enclosure having an external surface and an internal surface, said internal surface sufficiently smooth to prevent egress of said insects through said releasably sealable opening;

b) coupling a heater to said flexible enclosure, said heater capable of generating an amount of heat within said flexible enclosure to provide a temperature over a period of time lethal to said insects;

5 c) locating heat treatable materials infested with insects inside of said flexible enclosure;

d) establishing said releasably sealable opening in the closed condition; and

f) operating said heater to achieve a temperature over a period of time inside of said flexible enclosure lethal to said insects.

10 15. The method of killing insects in a structure of claim 14, further comprising the step of establishing said temperature within said flexible enclosure within a range of about 110°F and about 160°F.

15 16. The method of killing insects in a structure of claim 15, further comprising the step of allowing elapse of a period of time within a range of about 5 minutes and about 480 minutes.

20 17. The method of killing insects in a structure of claim 16, where said step of locating heat treatable materials infested with insects inside of said flexible enclosure comprises the step of locating heat treatable material inside of said flexible enclosure, said heat treatable material infested with insects selected from the group consisting of: bed bugs, powder post beetles, moths, roaches, termites, fleas, wasps, bees, cicadas, ants, lice, head lice, mites, grain beetles, flour beetles, fire ants, mosquitoes, leafhoppers, plant hoppers, ticks, and flies.

25 18. The method of killing insects in a structure of claim 17, further comprising the steps of:

a) sensing temperature inside of said flexible enclosure; and

b) indicating said temperature on a temperature indicator located outside of said flexible enclosure.

30 19. The method of killing insects in a structure of claim 18, further comprising the step of locating said heater inside of said flexible enclosure.

20. The method of killing insects in a structure of claim 19, further comprising the step of operating an enclosure support structure between a collapsed condition and an erect condition to correspondingly provide a reduced volume and operational volume of said flexible enclosure.

5

21. The method of killing insects in a structure of claim 20, wherein said step of operating an enclosure support structure between a collapsed condition and an erect condition to correspondingly provide a reduced volume and operational volume of said flexible enclosure comprises the step of providing a perforated platform having proximate opposed ends a pair of substantially linear members each having a first end rotatably coupled to opposed sides of said perforated shelf and each having second end correspondingly connected to opposed ends of a cross member to provide said enclosure support structure.

10

22. The method of killing insects in a structure of claim 21, further comprising the steps of:

15

a) configuring said perforated platform in substantially rectangular configuration;

b) locating said substantially rectangular configuration of said perforated platform inside of said flexible enclosure in substantially horizontal relation to said bottom side;

20

c) configuring said enclosure support in substantially rectangular configuration which in the erect condition locates inside of said flexible enclosure in substantially vertical relation to said bottom to define a rectangular operational volume within said flexible enclosure.

25

23. The method of killing insects in a structure of claim 22, further comprising the step of providing said reduced volume of said flexible enclosure in dimensional relations which allows a person to carry said heated structure.

24. A portable structure for killing insects infesting a heat treatable material, comprising:

30

a) a support structure;

b) a flexible material engaged to said support structure to define an enclosed space accessible through a releasably sealable opening;

c) a heater having a location inside of said enclosed space which generates sufficient heat to achieve a temperature within said enclosed space in a range of 110°F and 160°F over an uninterrupted period in a range of 5 minutes and 480 minutes; and

5 d) perforated platform having a location in said enclosed space about which said heat to circulates, said perforated platform configured to receive an amount of heat treatable material infested with said insects.

10 25. The portable structure for killing insects of claim 24, wherein said insects are selected from the group consisting of: bed bugs, powder post beetles, moths, roaches, termites, fleas, wasps, bees, cicadas, ants, lice, head lice, mites, grain beetles, flour beetles, fire ants, mosquitoes, leafhoppers, plant hoppers, ticks, and flies.

15 26. The portable structure for killing insects of claim 24 further comprising a thermometer having temperature sensor having a location inside of said enclosed space and a viewable temperature indicator having a location outside of said enclosed space.

20 27. The portable structure for killing insects of claim 24, wherein said support structure comprises a collapsible support structure which operates between a collapsed condition and an erect condition to correspondingly provide a reduced volume and operational volume of said enclosed space.

25 28. The portable structure for killing insects of claim 28, wherein proximate each of the opposed ends of said perforated platform said support structure includes a pair of substantially linear members each having a first end rotatably coupled to opposed sides of said perforated platform and each having a second end correspondingly connected to opposed ends of a cross member.

30 29. The portable structure for killing insects of claim 30, wherein said perforated platform has a substantially rectangular configuration which locates inside of said flexible enclosure in substantially horizontal relation to said bottom side, and wherein said enclosure support structure in the erect condition has a substantially rectangular configuration which locates inside of said flexible enclosure in substantially vertical relation to said bottom to define a rectangular operational volume within said flexible enclosure.

30. The portable structure for killing insects of claim 28, wherein said reduced volume of said enclosed space has dimensional relations which allow a person to carry said reduced volume of said portable structure.

5

31. The portable structure for killing insects of claim 24, wherein said flexible material engaged to said support structure has an external surface and an internal surface, said internal surface sufficiently smooth to prevent egress of said insects through said releasably sealable opening.

10

32. A method of killing insects in a structure, comprising the steps of:

a) providing a support structure;

b) engaging a flexible material to said support structure to define an enclosed space accessible through a releasably sealable opening;

15

c) locating a heater having inside of said enclosed space which generates sufficient heat to achieve a temperature within said enclosed space in a range of 110°F and 160°F over an uninterrupted period in a range of 5 minutes and 480 minutes; and

d) locating a perforated platform in said enclosed space about which said heat to circulates, said perforated platform configured to receive an amount of heat treatable material infested with said insects

20

33. The method of killing insects in a structure of claim 32, wherein said insects are selected from the group consisting of: bed bugs, powder post beetles, moths, roaches, termites, fleas, wasps, bees, cicadas, ants, lice, head lice, mites, grain beetles, flour beetles, fire ants, mosquitoes, leafhoppers, plant hoppers, ticks, and flies.

25

34. The method of killing insects in a structure of claim 32, further comprising the steps of:

a) sensing temperature inside of said flexible enclosure; and

30

b) indicating said temperature on a temperature indicator located outside of said flexible enclosure.

35. The method of killing insects in a structure of claim 32, further comprising the step of operating said support structure between a collapsed condition and an erect condition to correspondingly provide a reduced volume and operational volume of said enclosed space.

5 36. The method of killing insects in a structure of claim 35, wherein said step of operating said support structure between a collapsed condition and an erect condition to correspondingly provide a reduced volume and operational volume of said enclosed space comprises the step of providing a perforated platform having proximate opposed ends a pair of substantially linear members each having a first end rotatably coupled to opposed sides of
10 said perforated shelf and each having second end correspondingly connected to opposed ends of a cross member to provide said support structure.

37. The method of killing insects in a structure of claim 32, further comprising the steps of:

- 15 a) configuring said perforated platform in substantially rectangular configuration;
b) locating said substantially rectangular configuration of said perforated platform inside of said enclosed space in substantially horizontal relation to said bottom side;
c) configuring said support structure in substantially rectangular configuration which in the erect condition locates inside of said enclosed space in substantially vertical
20 relation to said bottom to define a rectangular operational volume within said flexible enclosure.

38. The method of killing insects in a structure of claim 35, further comprising the step of providing said reduced volume of said enclosed space in dimensional relations which allows
25 a person to carry said structure.

39. The method of killing insects in a structure of claim 32, further comprising the step of providing an external surface and an internal surface of said flexible material engaged to said support structure, said internal surface sufficiently smooth to prevent egress of said insects
30 through said releasably sealable opening.

40. A method of killing bed bugs on a heat treatable material in a portable structure, comprising the steps of:

a) placing said heat treatable material within an enclosed space defined by a flexible material engaged to a support structure;

b) activating a heater having a location inside of said enclosed space;

5 c) generating sufficient heat to achieve a temperature within said enclosed space in a range of 110°F and 160°F over an uninterrupted period in a range of 5 minutes and 480 minutes; and

d) removing said heat treatable material from within said enclosed space.

10 41. The method of killing bed bugs on a heat treatable material in a portable structure as described in claim 40, wherein said insects are selected from the group consisting of: bed bugs, powder post beetles, moths, roaches, termites, fleas, wasps, bees, cicadas, ants, lice, head lice, mites, grain beetles, flour beetles, fire ants, mosquitoes, leafhoppers, plant hoppers, ticks, and flies.

15 42. The method of killing bed bugs on a heat treatable material in a portable structure as described in claim 40, further comprising the steps of:

a) sensing temperature inside of said flexible enclosure; and

b) indicating said temperature on a temperature indicator located outside of said flexible enclosure.

20

43. The method of killing bed bugs on a heat treatable material in a portable structure as described in claim 40, further comprising the step of operating said support structure between a collapsed condition and an erect condition to correspondingly provide a reduced volume and operational volume of said enclosed space.

25

30 44. The method of killing bed bugs on a heat treatable material in a portable structure as described in claim 43, wherein said step of operating said support structure between a collapsed condition and an erect condition to correspondingly provide a reduced volume and operational volume of said enclosed space comprises the step of providing a perforated platform having proximate opposed ends a pair of substantially linear members each having a first end rotatably coupled to opposed sides of said perforated shelf and each having second end correspondingly connected to opposed ends of a cross member to provide said support structure.

45. The method of killing bed bugs on a heat treatable material in a portable structure as described in claim 44, further comprising the steps of:

a) configuring said perforated platform in substantially rectangular configuration;

5 b) locating said substantially rectangular configuration of said perforated platform inside of said enclosed space in substantially horizontal relation to said bottom side;

c) configuring said support structure in substantially rectangular configuration which in the erect condition locates inside of said enclosed space in substantially vertical relation to said bottom to define a rectangular operational volume within said flexible enclosure.

46. The method of killing bed bugs on a heat treatable material in a portable structure as described in claim 45, further comprising the step of providing said reduced volume of said enclosed space in dimensional relations which allows a person to carry said structure.

47. The method of killing bed bugs on a heat treatable material in a portable structure as described in claim 40, further comprising the step of providing an external surface and an internal surface of said flexible material engaged to said support structure, said internal surface sufficiently smooth to prevent egress of said insects through said releasably sealable opening.

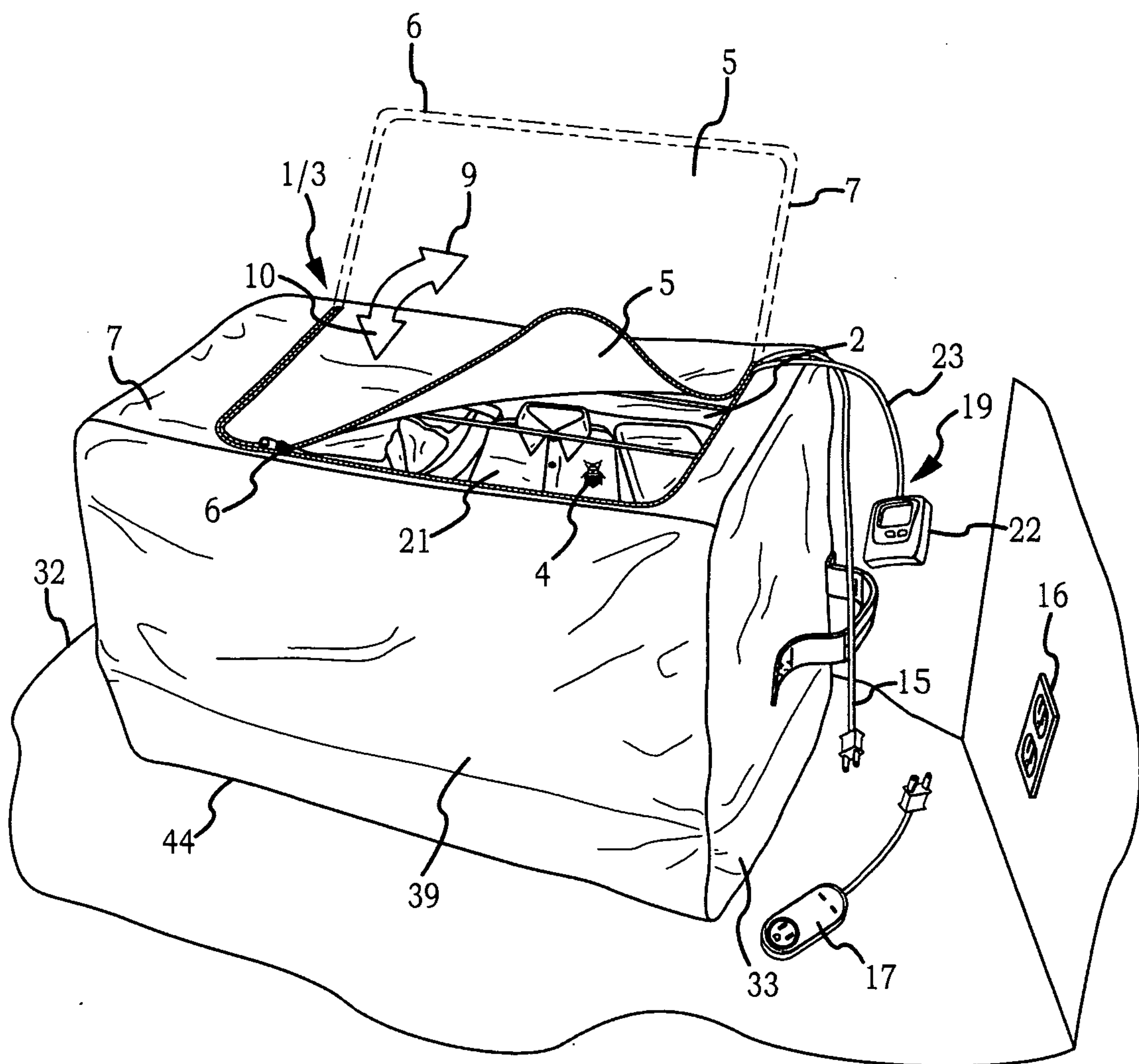

FIG. 1

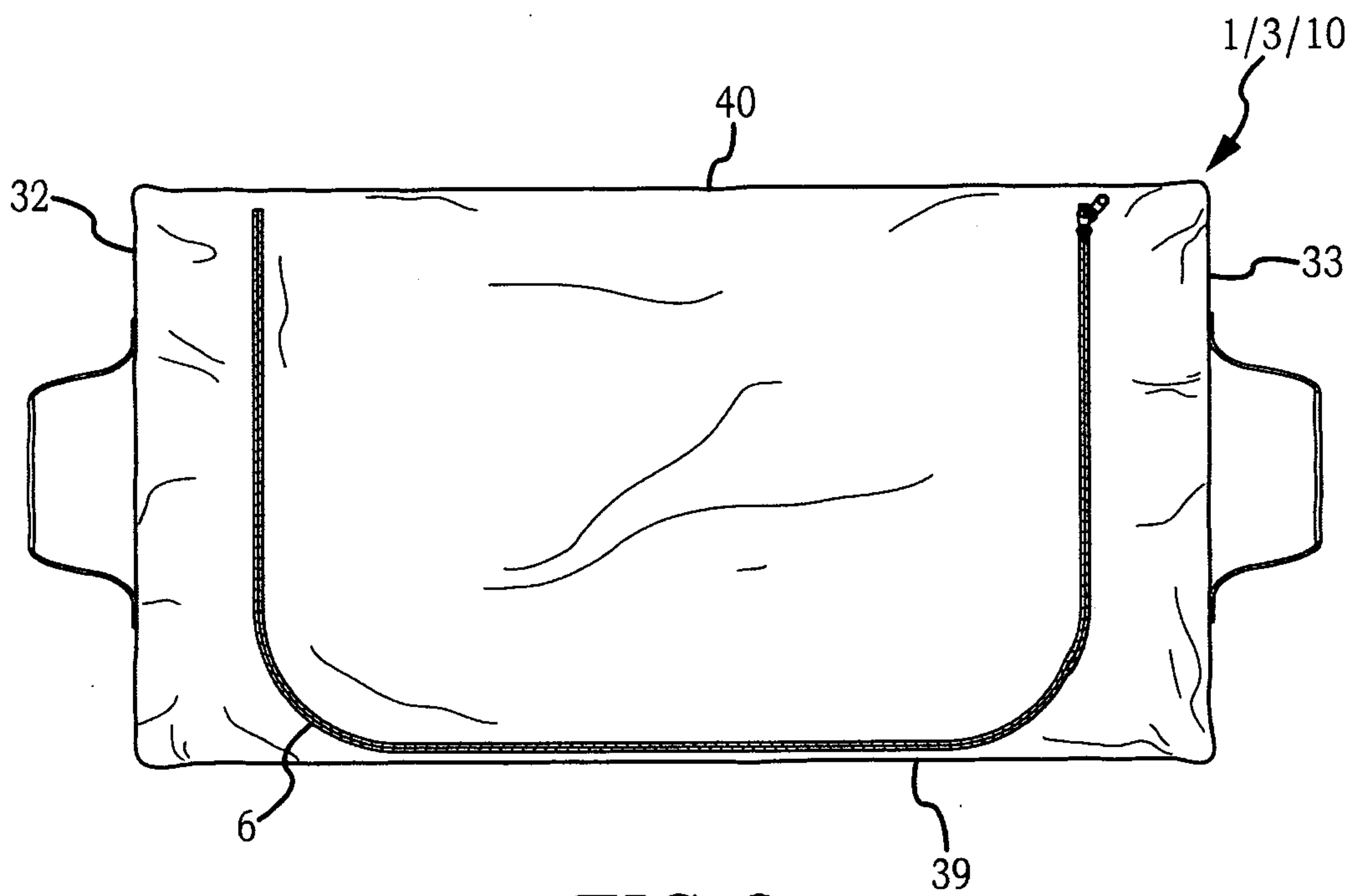

FIG. 2

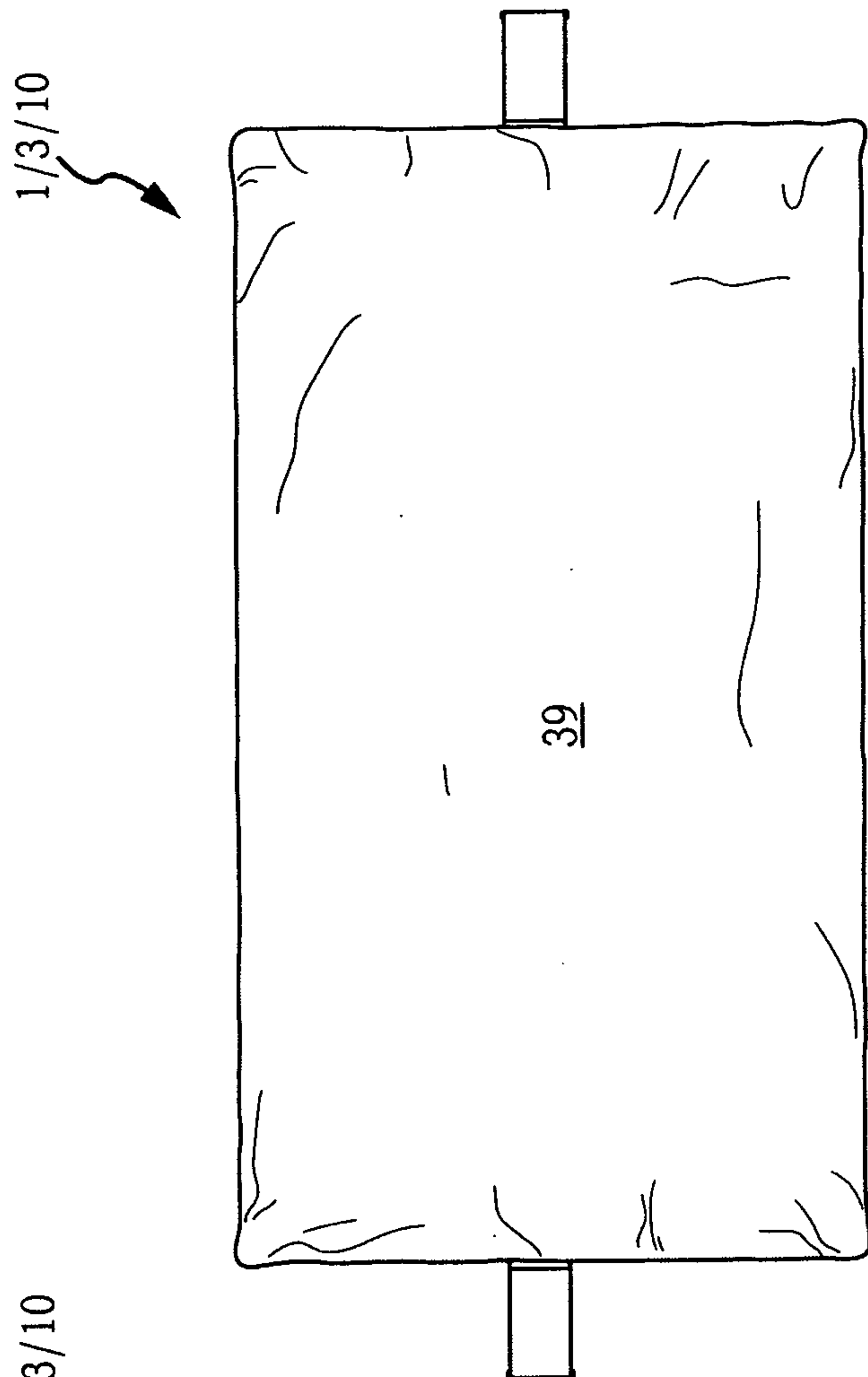

FIG. 3

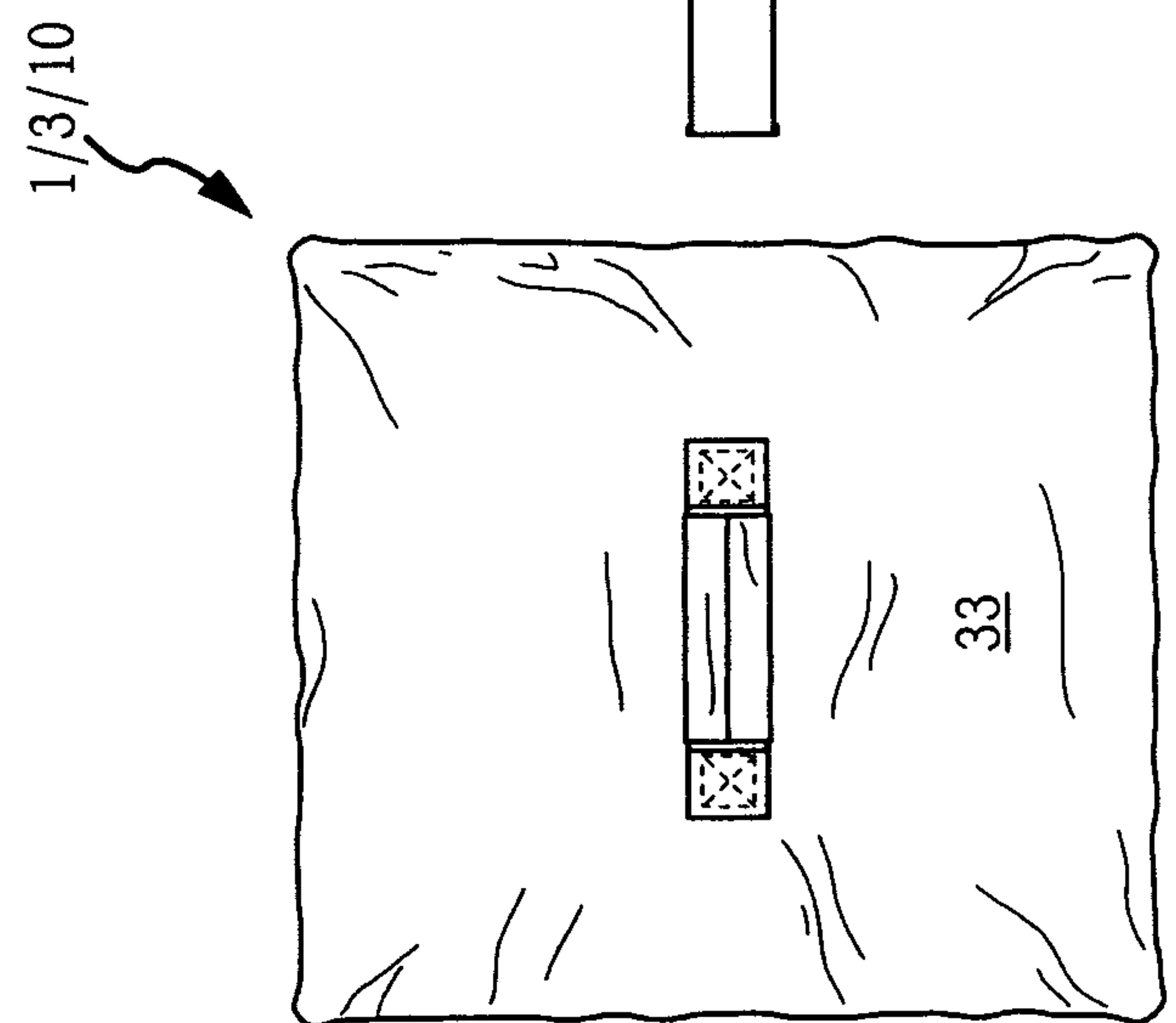

FIG. 4

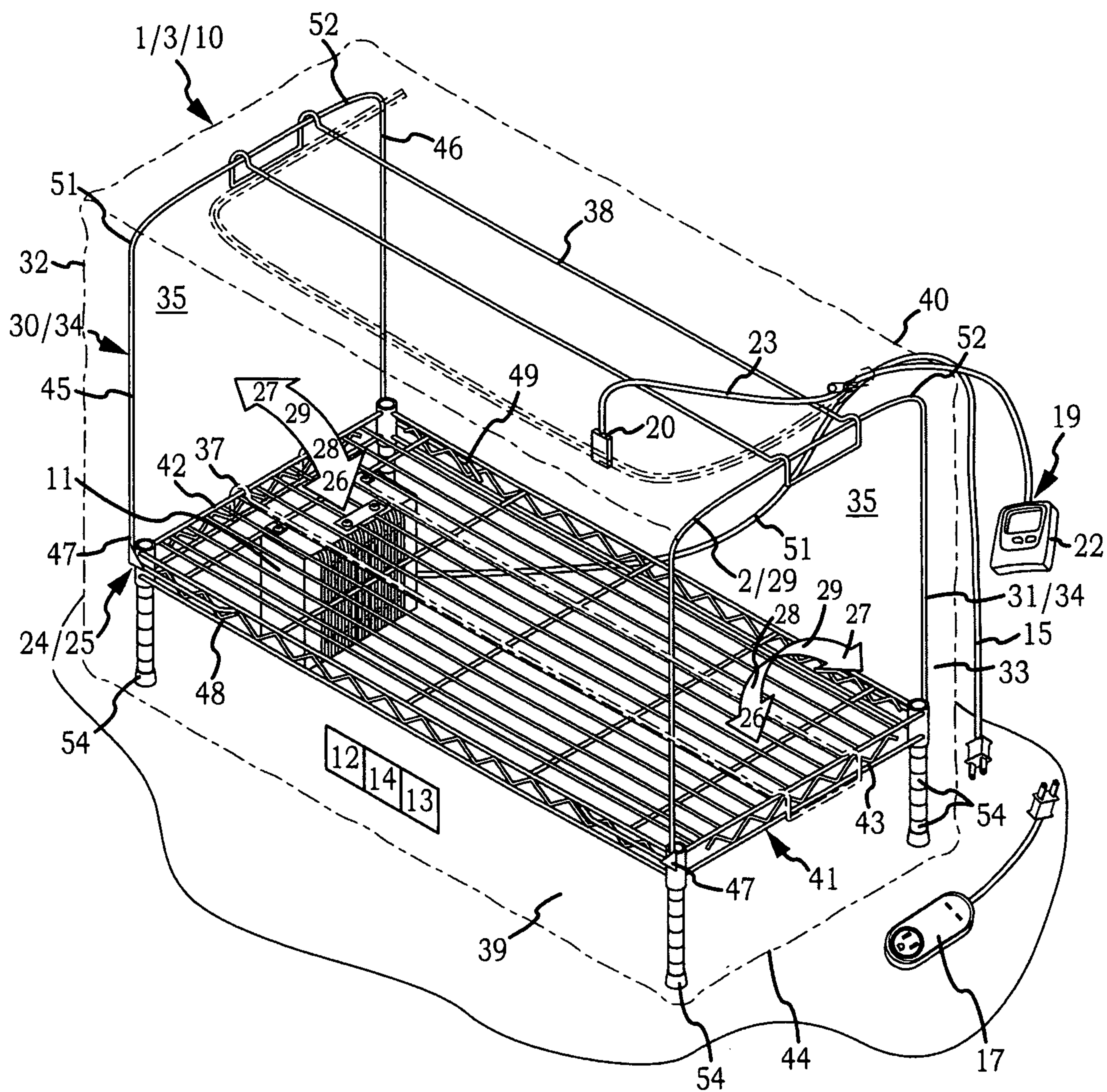

FIG. 5

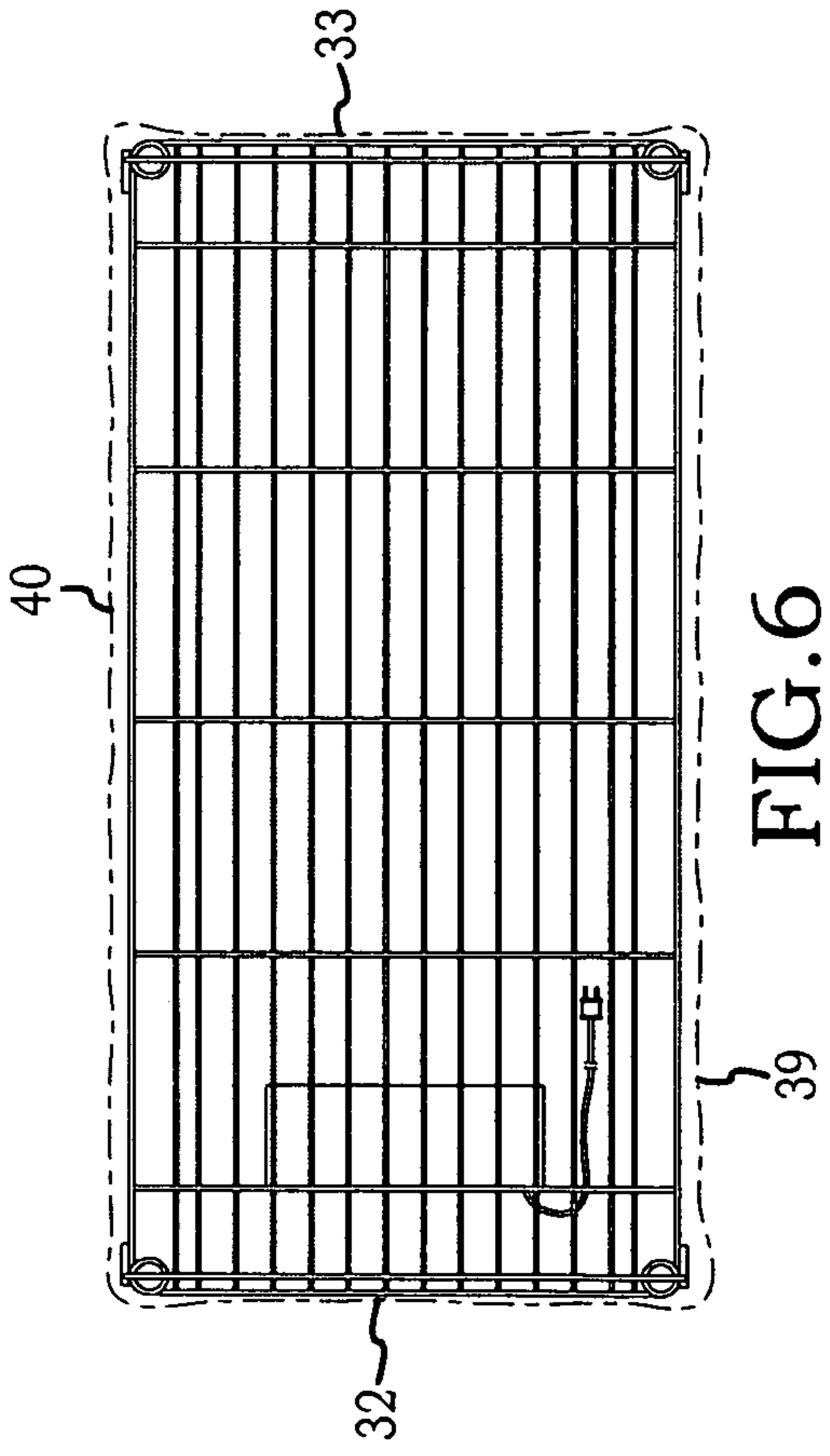

FIG. 6

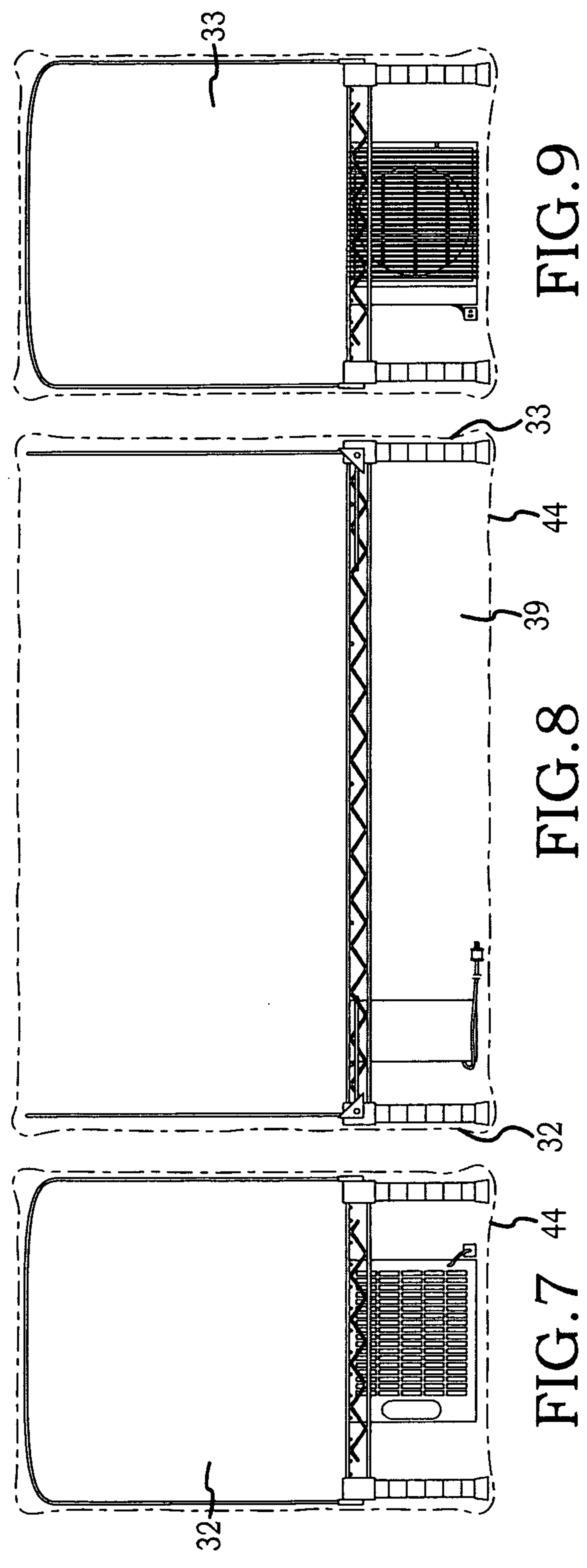

FIG. 7

FIG. 8

FIG. 9

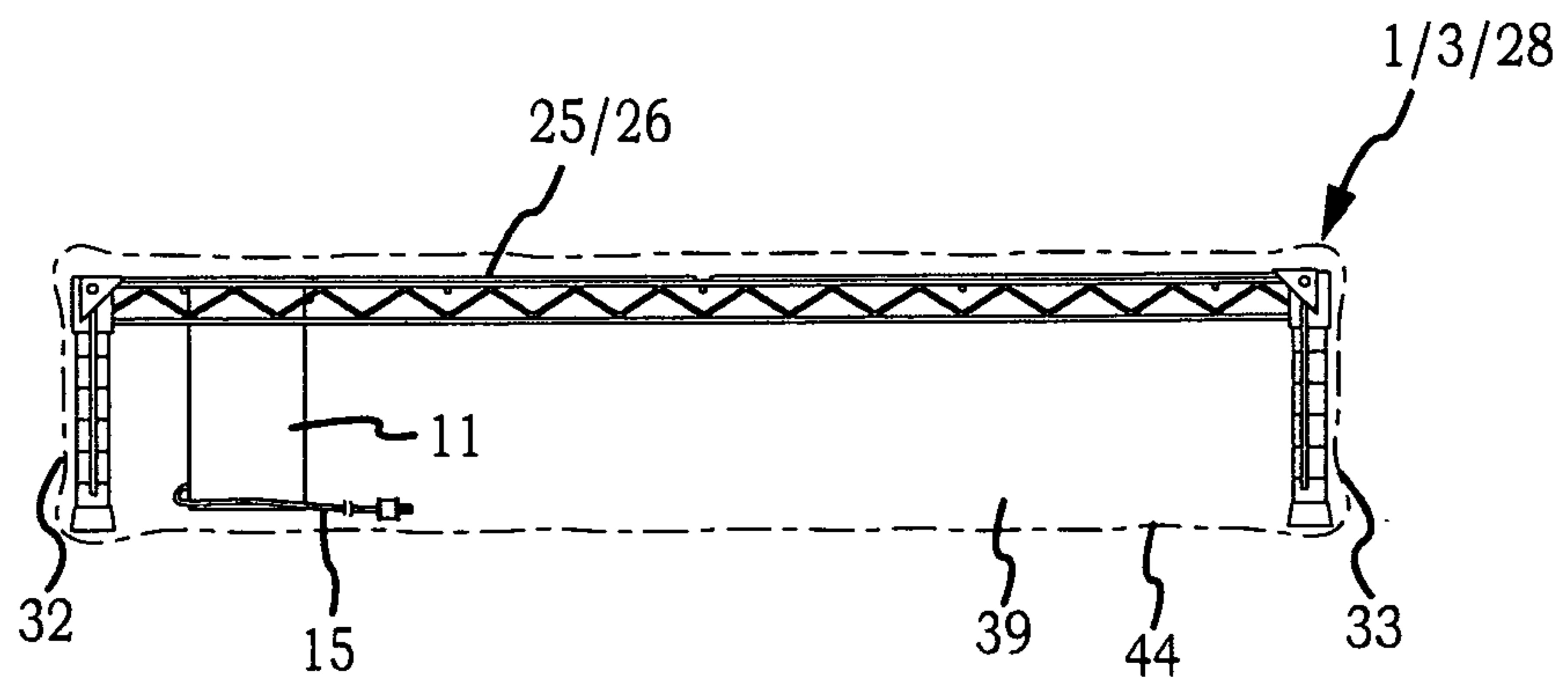

FIG. 10

