



- (51) **International Patent Classification:**
A61M 25/088 (2006.01) A61N 2/10 (2006.01)
A61N 2/06 (2006.01)
- (21) **International Application Number:**
PCT/US2014/029731
- (22) **International Filing Date:**
14 March 2014 (14.03.2014)
- (25) **Filing Language:** English
- (26) **Publication Language:** English
- (30) **Priority Data:**
61/785,509 14 March 2013 (14.03.2013) US
- (71) **Applicant:** TVA MEDICAL, INC. [US/US]; 7000 Bee Cave Road, Suite 250, Austin, TX 78746 (US).
- (72) **Inventor:** PATE, Thomas, Diffley; 1304 Pasadena Drive, Austin, TX 78757 (US).
- (74) **Agents:** AMII, Lisa, A. et al.; Morrison & Foerster LLP, 755 Page Mill Road, Palo Alto, CA 94304-1018 (US).
- (81) **Designated States** (unless otherwise indicated, for every kind of national protection available): AE, AG, AL, AM, AO, AT, AU, AZ, BA, BB, BG, BH, BN, BR, BW, BY, BZ, CA, CH, CL, CN, CO, CR, CU, CZ, DE, DK, DM,

DO, DZ, EC, EE, EG, ES, FI, GB, GD, GE, GH, GM, GT, HN, HR, HU, ID, IL, IN, IR, IS, JP, KE, KG, KN, KP, KR, KZ, LA, LC, LK, LR, LS, LT, LU, LY, MA, MD, ME, MG, MK, MN, MW, MX, MY, MZ, NA, NG, NI, NO, NZ, OM, PA, PE, PG, PH, PL, PT, QA, RO, RS, RU, RW, SA, SC, SD, SE, SG, SK, SL, SM, ST, SV, SY, TH, TJ, TM, TN, TR, TT, TZ, UA, UG, US, UZ, VC, VN, ZA, ZM, ZW.

- (84) **Designated States** (unless otherwise indicated, for every kind of regional protection available): ARIPO (BW, GH, GM, KE, LR, LS, MW, MZ, NA, RW, SD, SL, SZ, TZ, UG, ZM, ZW), Eurasian (AM, AZ, BY, KG, KZ, RU, TJ, TM), European (AL, AT, BE, BG, CH, CY, CZ, DE, DK, EE, ES, FI, FR, GB, GR, HR, HU, IE, IS, IT, LT, LU, LV, MC, MK, MT, NL, NO, PL, PT, RO, RS, SE, SI, SK, SM, TR), OAPI (BF, BJ, CF, CG, CI, CM, GA, GN, GQ, GW, KM, ML, MR, NE, SN, TD, TG).

Published:

- with international search report (Art. 21(3))
- before the expiration of the time limit for amending the claims and to be republished in the event of receipt of amendments (Rule 48.2(h))

(54) **Title:** FISTULA FORMULATION DEVICES AND METHODS THEREFOR

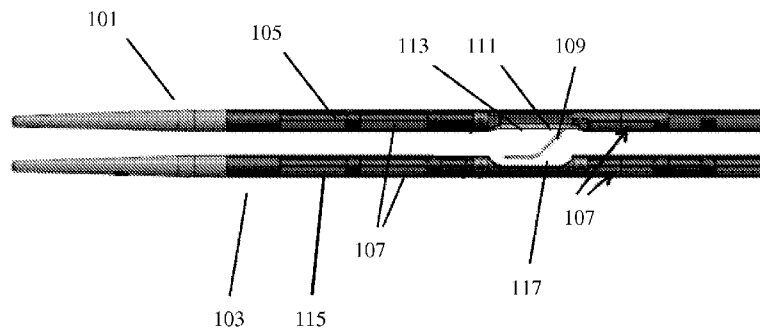
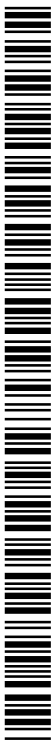

FIG. 1

(57) **Abstract:** Described here are devices, systems, and methods for forming a fistula between two blood vessels. Generally, the systems may comprise a first catheter and a second catheter, which may comprise one or more fistula-forming elements. The first and second catheters may comprise one or more magnetic elements, which may be used to assist in bringing the first and catheters in closer proximity to facilitate fistula formation. In some variations, the magnetic elements may have magnetization patterns such that the flux generated by the magnetic elements is locally concentrated. In some instances, the system may comprise a magnetic control device, which may comprise a magnet, and may be used to increase or create an attractive force between the first and second catheters.



FISTULA FORMULATION DEVICES AND METHODS THEREFOR

CROSS-REFERENCE TO RELATED APPLICATIONS

[0001] This application claims priority to U.S. Provisional Application Serial No. 61/785,509, filed on March 14, 2013, and titled “FISTULA FORMULATION DEVICES AND METHODS THEREFOR,” the content of which is hereby incorporated in its entirety.

FIELD

[0002] The current invention relates to devices and methods for forming a fistula. The devices and methods may be used to form a fistula between two blood vessels.

BACKGROUND

[0003] A fistula is generally a passageway formed between two internal organs. Forming a fistula between two blood vessels can have one or more beneficial functions. For example, the formation of a fistula between an artery and a vein may provide access to the vasculature for hemodialysis patients. Specifically, forming a fistula between an artery and a vein allows blood to flow quickly between the vessels while bypassing the capillaries. In other instances, a fistula may be formed between two veins to form a veno-venous fistula. Such a veno-venous fistula may be used to help treat portal venous hypertension. Generally, fistula formation requires surgical dissection of a target vein, and transecting and moving the vein for surgical anastomosis to the artery. It may therefore be useful to find improved ways to form a fistula between two blood vessels.

BRIEF SUMMARY

[0004] Described here are devices and systems for forming a fistula. In some variations, the systems described here may comprise a first catheter and a second catheter. The first catheter may comprise one or more fistula-forming elements. Additionally or alternatively, the second catheter may comprise one or more fistula-forming elements. The first and second catheters may comprise one or more magnetic elements, which may be used to move the first and second catheters in closer proximity to facilitate fistula

formation. In some variations, the magnetic elements may have magnetization patterns such that the magnetic field generated by the magnetic elements is locally concentrated. In some instances, the system may comprise a magnetic control device, which may comprise a magnet, and may be used to increase or create an attractive force between the first and second catheters.

[0005] In some variations of the systems described here, the system may comprise a first catheter comprising a first magnetic element and a second catheter comprising a second magnetic element, such that at least one of the first and second catheters comprises a fistula-forming element. The fistula-forming element may be any suitable structure, such as an electrode. In some variations, the first magnetic element may be configured to produce a magnetic field that is stronger on a first side of the first magnetic element than on a second side of the magnetic element. In some variations, the first magnetic element may comprise a plurality of regions each having a polarity. The plurality of regions of the first magnetic element may be configured such that the polarity of each region is rotated a first angle relative to the polarity of an immediately-preceding region in a proximal-to-distal direction. In some of these variations, the second magnetic element may comprise a plurality of regions each having a polarity. The plurality of regions of the second magnetic element may be configured such that the polarity of each region is rotated a second angle relative to the polarity of an immediately-preceding region in a proximal-to-distal direction. The first angle may or may not be the same as the second angle. The first and second angles may be any suitable angles (e.g., about 30 degrees, about 45 degrees, about 90 degrees). In some variations, the first magnetic element may have a plurality of regions such that the polarity of each region is rotated a first angle clockwise relative to an immediately-preceding region, and the second magnetic element may have a plurality of regions such that each region is rotated a first angle counterclockwise relative to an immediately-preceding region.

[0006] In some variations, the systems may comprise a magnetic control device, which may comprise a housing having a contact surface for placement against the skin, a magnet, and a control element connected to the magnet and moveable relative to the housing such that the control element may move the magnet relative to contact surface. In some variations, the magnet may comprise a magnetic array having a magnetization

pattern. In some variations, the housing and/or control element may comprise one or more finger rings.

BRIEF DESCRIPTION OF THE DRAWINGS

[0007] FIG. 1 is an illustrative depiction of a variation of a system described here comprising a first catheter and a second catheter.

[0008] FIGS. 2A-2B, 3A-3B, and 4 are illustrative depictions of variations of magnetic arrays having magnetization patterns suitable for use with the catheters described here.

[0009] FIGS. 5A-5B are illustrative depictions of a perspective view and a cross-sectional side view, respectively, of a variation of a magnetic control device as described here.

[0010] FIGS. 6A-6B, and 7-10 are illustrative depictions of variations of magnetic arrays having magnetization patterns suitable for use with magnetic control devices described here.

[0011] FIGS. 11A-11C are illustrative depictions of a method of manipulating one or more catheters using one or more externally placed magnets.

DETAILED DESCRIPTION OF THE INVENTION

[0012] Generally described here are systems, devices, and methods for forming a fistula between blood vessels. The fistula may be, for example, an arteriovenous fistula between an artery and a vein, or a veno-venous fistula between two veins. Generally, to form a fistula between two blood vessels, one or more catheters may be advanced in a minimally invasive fashion through the vasculature to a target fistula formation site. Typically, a catheter may be placed in each of the two blood vessels, such that a first catheter may be positioned in a first blood vessel and a second catheter may be positioned in a second blood vessel. Accordingly, the systems described here may comprise a first catheter and a second catheter.

[0013] The first and second catheters may have one or more magnetic elements, which may be configured to aid in positioning and/or alignment of the catheters. For

example, in some instances the first catheter may comprise one or more magnetic elements which may be attracted to one or more magnetic elements of the second catheter, which may act to pull the first and second catheters toward each other. In some variations, the magnetic elements may have magnetization patterns such that the strength of a magnetic field generated by the magnetic element is greater on one side of the magnet than on an opposite side.

[0014] In some variations, the systems may also comprise a magnetic control device for applying a magnetic force to the first and second catheters using an external magnet positioned outside of the body. The magnetic control device may comprise a control element that may help to adjust the position of the external magnet in a controlled manner. In some instances, the external magnet may have a magnetization pattern such that the strength of the magnetic field generated by the external magnet is greater on one side of the magnet than on an opposite side. It should be appreciated that each catheter may or may not have the same configuration of elements, and that some catheters may be different from and/or complementary to other catheters.

Devices

Catheters

[0015] As mentioned above, the systems described here typically comprise a first catheter and a second catheter. Any suitable catheter or catheters may be used with the systems described here to form the fistulas using the methods described here. For example, in some variations the system may comprise one or more of the catheters described in U.S. Patent Application Serial No. 13/298,169, filed on November 16, 2011 and titled "DEVICES AND METHODS FOR FORMING A FISTULA," the contents of which are hereby incorporated by reference in their entirety. Generally, each catheter may have a proximal end, a distal end, and an intermediate portion connecting the proximal and distal ends. The proximal end may comprise one or more adaptors or handles, which may be utilized to help aid in advancement, positioning, and/or control of the catheter within the vasculature, and may further be used to actuate one or more components of the catheter and/or introduce one or more fluids or substances into and/or through the catheter. The catheter may comprise one or more elements that may aid in fistula formation. For example, one or more portions (e.g., the distal end and/or the intermediate portion) of the

catheter may comprise one or more elements, such as magnets, that may help to align the catheter with another catheter positioned in a related blood vessel, and/or help to bring the catheters into closer approximation, as will be described in more detail below. As the catheters are brought in to closer approximation, the blood vessels within which the catheters are positioned may be brought into closer approximation, which may aid in fistula formation. Additionally or alternatively, one or more portions (e.g., the distal end and/or an intermediate portion) of the catheter may comprise one or more mechanisms for forming a fistula.

[0016] The catheters may additionally comprise one or more lumens or passageways extending at least partially along or through the catheter, and may be used to pass one or more guidewires, one or more drugs or fluids (e.g., contrast agents, perfusion fluids), combinations thereof, or the like at least partially along or through the catheter, but need not comprise these lumens or passageways. The distal tip of the catheter may be configured to aid in advancement of the catheter and/or to be atraumatic. In some variations, the tip may comprise one or more rapid exchange portions or other lumens for advancement of the catheter over a guidewire. In still other variations, the tip portion may have a guidewire attached to or otherwise integrally formed with the catheter.

[0017] Additionally, in some variations the catheters may further comprise one or more external expandable elements (e.g., a balloon, expandable cage, mesh, or the like) that may help position a catheter within a blood vessel, but need not comprise one or more external expandable elements. Additionally or alternatively, the one or more expandable elements may affect the flow of blood through one or more blood vessels (e.g., by temporarily occluding blood flow through the blood vessel, dilating one or more portions of a blood vessel, constricting one or more portions of a blood vessel, or the like). In some instances, one or more expandable elements may act to temporarily anchor a portion of the catheter relative to a blood vessel. In variations where the catheter comprises one or more shape-changing elements, as will be described in more detail below, the use of an expandable element to temporarily anchor a portion of the catheter relative to a blood vessel may aid in altering the shape of the catheter. It should be appreciated that the catheters described here may have any combination of the aforementioned elements.

[0018] FIG. 1 shows an illustrative variation of a catheter system that may be used to form a fistula between two vessels. As shown there, the system may comprise a first

catheter (101) and a second catheter (103). The first catheter (101) may comprise a catheter body (105), one or more magnetic elements (107), and a fistula-forming element (109) which may be activated to form a fistula. In some variations, the fistula-forming element (109) may be advanced to project out of an opening (111) in the catheter body (105). In some variations, the first catheter (101) may comprise a housing (113), which may help protect other components of the first catheter (101) during fistula formation. For example, when the fistula-forming element (109) comprises an electrode configured to ablate tissue, the housing (113) may comprise one or more insulating materials which may shield or otherwise protect one or more components of the first catheter (101) from heat that may be generated by the electrode during use.

[0019] As shown in FIG. 1, the second catheter (103) may also comprise a catheter body (115) and one or more magnetic elements (107). In variations where the first catheter (101) comprises a fistula-forming element (109) configured to project out the catheter body (105) of the first catheter (101), such as the variation depicted in FIG. 1, the catheter body (115) of the second catheter (103) may comprise a recess (117) therein, which may be configured to receive the fistula-forming element (109) as it passes through tissue. In some of these variations, the recess (117) may be coated by an insulating material (not shown), which may be configured to protect one or more components of the second catheter (103) from being damaged by the fistula-forming element (109) (e.g., the insulating material may shield one or more components of the second catheter (103) from heat that may be generated by the fistula-forming element (109)). While shown in FIG. 1 as having a recess (117), it should also be appreciated that in some variations the second catheter (103) may not comprise a recess (117). In some variations, the second catheter may comprise a fistula-forming element (not shown) in addition to or instead of the fistula-forming element (109) of the first catheter (101), as will be described in detail below.

Fistula-Forming Elements

[0020] As mentioned above, the catheters described here may comprise one or more elements for forming a fistula. The fistula-forming element may comprise any element capable of forming a fistula between two vessels, such as those elements described in U.S. Patent Application Serial No. 13/298,169, which was previously incorporated by reference in its entirety. For example, the fistula-forming element may

comprise one or more electrical mechanisms (e.g., electrodes or electrocautery mechanisms); one or more mechanical mechanisms (e.g., blades, lances, needles, or the like); one or more chemical devices (e.g., enzyme-releasing devices); one or more cryogenic-cautery devices; one or more laser ablation devices; and/or combinations thereof, and the like. A catheter may have any suitable number (e.g., zero, one, two, three, or four or more) and combination of these fistula-forming elements. The fistula-forming elements may be located in or on any suitable portion of the catheter (e.g., the distal end, an intermediate portion, or combinations thereof). In variations where a catheter comprises two or more fistula-forming elements, multiple fistula-forming elements may be used to create multiple fistulas, either simultaneously or sequentially. In other variations, multiple fistula-forming elements may interact to form a single fistula.

[0021] In variations where a system comprising multiple catheters is used to create a fistula between two blood vessels, each catheter may comprise a fistula-forming element, but need not. Indeed, in some of these variations, only one catheter may comprise a fistula-forming element. In some of these instances, the other catheter may still help align the catheters and/or approximate the blood vessels, but may not directly contribute to tissue removal. In variations where multiple catheters each comprise a fistula-forming element, the catheters may have complimentary fistula-forming elements. For example, in variations where two or more catheters comprise electrodes, one catheter may comprise an electrode that acts as an active electrode, while another catheter may comprise an electrode that acts as a passive or ground electrode.

[0022] In some variations of the catheters described here, a catheter may comprise one or more electrodes for use in forming a fistula. When a fistula-forming element comprises an electrode, it may be used to ablate or otherwise remove the tissue in contact with the electrode in order to form the fistula. If a fistula-forming element comprises an electrode, the electrode may be configured as described in U.S. Patent Application Serial No. 13/298,169, which was previously incorporated by reference in its entirety.

[0023] In the embodiment shown in FIG. 1, the fistula-forming element (109) of the first catheter (101) may comprise an electrode. The electrode may be selectively moved from a position in which the electrode is retained or otherwise held in the catheter body (105) to a position in which the electrode extends away from the catheter body (105) (e.g., through the opening (111)), and the electrode may also be selectively moved back to

a retracted/low-profile position (either the same or a different position as the previous retracted position) following ablation of tissue. This may allow the electrode to be maintained in a low-profile configuration during positioning of the catheter. In some variations, the electrode may be biased toward an extended position when not otherwise restrained by the catheter body (105).

Magnetic Elements

[0024] As mentioned above, the first and second catheters of the systems described here may comprise one or more magnetic elements. Generally, the magnetic elements may be configured to be attracted to one or more magnetic fields (e.g., produced by one or more magnetic elements of another catheter, produced by one or more magnets positioned external to the body). The magnetic element or elements may help to align or otherwise reposition the catheters when placed in the vasculature. In some instances, a system may comprise first and second catheters each having one or more magnetic elements, such that magnetic elements of the first catheter may be attracted to magnetic elements of the second catheter to bring the catheters in closer approximation. Additionally or alternatively, one or more external magnetic elements may be positioned outside of the body, and may attract the one or more magnetic elements of the first and/or second catheters to help reposition the first and/or second catheters, as will be described in more detail below. In other instances, one or more magnetic elements may help to ensure that one or more catheters are in proper axial or rotational alignment relative to another catheter or catheters, such as described in further detail in U.S. Patent Application Serial No. 13/298,169, which was previously incorporated by reference in its entirety, which may facilitate alignment of one or more fistula-forming elements relative to a target fistula-formation site.

[0025] When the catheters described here comprise a magnetic element, it should be appreciated that the magnetic element may be configured to generate a magnetic field, but need not. For example, in some variations a catheter may have a magnetic element formed from one or more ferromagnetic materials configured to become temporarily magnetized when exposed to a magnetic field. In these variations, when the magnetic element is placed in a magnetic field (such as one produced by a magnetic element of another catheter), the temporary magnetization may provide an attractive force to the catheter to move or reposition the catheter. Examples of suitable ferromagnetic materials

which may be temporarily, but are not limited to, cobalt, gadolinium, iron, nickel, alloys of these metals with or without other metals such as alnico, chemical compounds such as ferrites, and/or a combination of any of these metals or their alloys.

[0026] In instances where the magnetic element is configured to generate a magnetic field, the magnetic element may comprise a permanent magnet or an electromagnet. When a magnetic element comprises a permanent magnet, the magnet may be made of any suitable material capable of generating a magnetic field. In some instances, the magnetic elements may be permanent magnets made out of ferromagnetic materials. For example, in some variations, the magnetic elements may comprise one or more rare-earth magnets (e.g. samarium-cobalt magnets or neodymium magnets), and/or cobalt, gadolinium, iron, nickel, alloys of these metals with or without other metals such as alnico, chemical compounds such as ferrites, and/or a combination of any of these metals or their alloys. When a magnetic element comprises an electromagnet, the electromagnet may be selectively activated to produce a magnetic field. For example, when one or more catheters of the systems described here comprise one or more electromagnets, the electromagnets may be activated before fistula formation to bring the blood vessels within which the catheters are located in closer approximation; they may remain activated during fistula formation to hold the vessels in closer approximation during the fistula-formation procedure; and then they may be deactivated after the fistula-formation procedure is complete. When a catheter comprises multiple electromagnet-based magnetic elements, these magnetic elements may be independently activated or may be activated as a group.

[0027] When the systems described here comprise a first catheter and a second catheter each comprising one or more magnetic elements, each catheter may comprise any combination of permanent magnets, ferromagnetic elements, or electromagnets. For example, in some variations, the first catheter may include only permanent magnets. In these variations, the second catheter may include only permanent magnets, only ferromagnetic elements, only electromagnets, or a mix of some or all of these elements. In other variations the first catheter may include only ferromagnetic elements. Again, the second catheter may include only permanent magnets, only ferromagnetic elements, only electromagnets, or a mix of some or all of these elements. In still other variations, the first catheter may include a permanent magnets and ferromagnetic elements. In these

variations, the second catheter may include only permanent magnets, ferromagnetic elements, only electromagnets, or a mix of some or all of these elements.

[0028] When the catheters of the systems described here comprise one or more magnetic elements, each catheter may comprise any number of individual magnetic elements (e.g., one, two, three, four, five, six, seven, or eight or more, etc.). In variations where a catheter comprises a plurality of magnetic elements, these magnetic elements may be grouped into one or more arrays. The magnetic elements or arrays may be located inside or outside of a catheter body or both. The magnetic elements or arrays may be positioned anywhere along the length of the catheter. In some variations where the system comprises a first catheter having a fistula-forming element (such as the first catheter (101) shown in FIG. 1), the first catheter may comprise one or more magnetic elements or arrays proximal to a fistula-forming element. Additionally or alternatively, the first catheter may comprise one or more magnetic elements or arrays distal to a fistula-forming element. In some variations in which a system comprises a second catheter comprising a fistula-forming element, the second catheter may comprise one or more magnetic elements or arrays proximal to the fistula-forming element. Additionally or alternatively, when the second catheter comprises a fistula-forming element, the second catheter may comprise one or more magnetic elements or arrays distal to the fistula-forming element. In variations where both the first and second catheters comprise one or more magnetic elements or arrays, each magnetic element or array in the first catheter may be configured to align with one or more magnetic elements or arrays in a second catheter. Each magnetic element may be fixed in or on a catheter by any suitable method. For example, in some variations one or more magnetic elements may be embedded in, adhered to, or friction-fit within a catheter.

[0029] Each magnetic element included in the catheters described here may have any suitable size and shape. For example, each magnetic element may be cylindrical, semi-cylindrical, tube-shaped, box-shaped, planar, spherical, or the like. Generally, the dimensions of the magnetic elements may be constrained by size of the catheters carrying the magnetic elements, which in turn may be constrained by the anatomical dimensions of the vessels through which the catheters described here may be advanced. For example, if the catheter is to be advanced through a blood vessel having an internal diameter of about 3 mm, it may be desirable to configure any magnetic element to have an outer diameter of

less than about 3 mm to reduce the risk of injury to vessel walls during advancement and manipulation of the catheter. Each magnetic element may have any suitable length (e.g., about 5 mm, about 10 mm, about 15 mm, about 20 mm, or the like), although it should be appreciated that in some instances longer magnets may limit the flexibility of the catheter to maneuver through tissue.

[0030] As mentioned above, when two catheters each comprise one or more magnetic elements, the magnetic elements of the catheters may produce an attractive force between the catheters which may act to pull the catheters into closer approximation. Once the first and second catheters have been positioned, the attractive force may also act to maintain the relative positioning between the catheters. When the first and second catheters are placed in respective blood vessels, tissue positioned between the blood vessels may limit the ability of the first and second catheters to be brought toward each other. Accordingly, it may be desirable to maximize the attractive force between the first and second catheters in order to help the first and second catheters to displace tissue between the blood vessels.

[0031] In some variations, in order to increase the attractive force between two catheters, it may be desirable to focus the strength of a magnetic field generated by a magnetic element or array of magnetic elements. In some instances, it may be desirable to focus the magnetic field produced by a magnetic element or array of magnetic elements such that the strength of the magnetic field is greater on one side of the magnet than the strength of the magnetic field produced on an opposite side of the magnet. In other words, these locally-concentrated magnetic elements may have a magnetic flux distribution that is greater on one side of the magnetic element than on an opposite side of the magnetic element. In some variations, one or more magnetic elements may be configured to have a substantially one-sided flux distribution. In these variations, the one or more magnetic elements may be configured such that the magnetic elements produce a magnetic field on a first side of the magnetic elements, but do not produce a significant magnetic field on a second side of the magnetic elements. Accordingly, the flux distribution of the magnetic elements is limited to the first side of the magnetic elements, also known as a “one-sided flux” arrangement. While a one-sided flux arrangement ideally produces no flux distribution on the second side of the magnetic elements, it should be appreciated that in practice a one-sided flux arrangement may produce negligible stray field on the second

side of the magnetic elements (e.g., due to imperfections in the machining process or due to assembly of individually magnetic elements). When one or more magnetic elements are configured as a one-sided flux arrangement, the strength of the magnetic field produced on the first side of the magnetic elements may be twice the strength of a magnetic field produced by a standard magnet of a similar size, shape, and construction. In other variations, one or more magnetic elements may be configured to produce a magnetic field that is stronger on a first side of the magnetic elements than it is on a second side of the magnetic elements opposite the first side of the magnetic elements, but to a lesser extent than a one-sided arrangement. For example, in some variations, one or more magnetic elements may be configured to generate a magnetic field having a flux distribution on a first side of the magnetic elements that is about 1.5 times as much as the flux distribution on a second side of the magnetic elements, about 2 times as much as the flux distribution on a second side of the magnetic elements, about 3 times as much as the flux distribution on a second side of the magnetic elements, about 5 times as much as the flux distribution on a second side of the magnetic elements, or the like.

[0032] Generally, to create a focused magnetic field as described immediately above, a catheter may comprise one or more magnets having a magnetization pattern, such as a Halbach array, configured to generate the desired magnetic field. Generally, the one or more magnets may comprise an array of regions, where each region has a specific polarity. The direction of the polarity of each respective region may be selectively arranged to produce a pattern of magnetic polarities, which may alter overall magnetic field produced by the array. The array may be formed from one or multiple discrete magnets, as will be discussed in more detail below.

[0033] FIG. 2A depicts one variation of a pair of magnetic arrays which may be configured to produce focused magnetic fields. Shown there are a first magnetic array (201) and a second magnetic array (203). The first magnetic array (201) may be configured to produce a magnetic field (not shown) that is stronger on a first side (i.e., the right side of the array as depicted in FIG. 2A) of the array than on an opposite second side (i.e., the left side of the array as depicted in FIG. 2A) of the array. The second magnetic array (203) may be configured to produce a magnetic field (not shown) that is stronger on a first side (i.e., the left side of the array as depicted in FIG. 2A) of the array than on an opposite second side (i.e., the right side of the array as depicted in FIG. 2A) of the array.

When the first magnetic array (201) and second magnetic array (203) are positioned such that the first side of the first magnetic array (201) faces the first side of the second magnetic array (203) (such as shown in FIG. 2A), the magnetic field produced by the first magnetic array (201) may attract the second magnetic array (203) toward the first magnetic array (201), while the magnetic field produced by the second magnetic array (203) may in turn attract the first magnetic array (201) toward the second magnetic array (203). Because the fields produced by these magnetic arrays are localized, the attractive force provided by the arrays may be greater than those produced by other similarly-sized magnets.

[0034] Generally, each of the magnetic arrays (201) and (203) are divided into a plurality of regions (215), wherein each region has a magnetic polarity (represented by arrows (213)). The direction of the polarities of the regions (215) may change from one region to the next according to a magnetization pattern. For example, in the variation of the first magnetic array (201) depicted in FIG. 2A, the first magnetic array (201) may have a proximal end (205) and a distal end (209), and may have a magnetization pattern in which the polarity of each region is rotated 90 degrees clockwise from the polarity of an immediately preceding region when looking at the magnetization pattern in a proximal-to-distal direction. Four regions (215a), (215b), (215c), and (215d) of the first magnetic array (201) having respective polarities (213a), (213b), (213c), and (213d) are marked in FIG. 2A to help illustrate this pattern. As shown there, region (215a) has a polarity (213a) in a first direction (e.g., to the left, as shown in FIG. 2A). Region (215b), the next region distal to region (215a), has a polarity (213b) in a direction that is rotated 90 degrees clockwise relative to the polarity (213a) of region (215a) (e.g., toward the distal end (209) as depicted in FIG. 2A). Similarly, region (215c), the next region distal to region (215b), has a polarity (213c) in a direction that is rotated 90 degrees clockwise relative to the polarity (213b) of region (215b) (e.g., toward the right as depicted in FIG. 2A). Finally, region (215d), the next region distal to region (215c), has a polarity (213d) in a direction that is rotated 90 degrees clockwise relative to the polarity (213c) of region (215c) (e.g., toward the proximal end (205) as depicted in FIG. 2A). This pattern may be continued along the length of the first magnetic array (201). In the first magnetic array (201) shown in FIG. 2A, each region (215) may produce a magnetic field, but the alternating polarities between adjacent regions may at least partially cancel out the magnetic field produced on the left side of the magnetic array (201) while augmenting the magnetic field produced on

the right side of the magnetic array (201). It should be appreciated that the magnetic arrays described here having magnetization patterns may have any suitable number of regions (e.g., two or more regions, three or more regions, four or more regions, five or more regions, ten or more regions, or the like).

[0035] Similarly, in the variation of the second magnetic array (203) depicted in FIG. 2A, the second magnetic array (203) may have a proximal end (207) and a distal end (211), and may have a magnetization pattern in which the polarity of each region is rotated 90 degrees from the polarity of an immediately preceding region when looking at the magnetization pattern in a proximal-to-distal direction. In the second magnetic array (203), the polarity of each region is rotated 90 degrees counter-clockwise from an immediately preceding region, as opposed to clockwise as in the first magnetic array (201). In these instances, each region (215) may again produce a magnetic field, but the alternating polarities between adjacent regions may at least partially cancel out the magnetic field produced on the right side of the magnetic array (203) while augmenting the magnetic field produced on the left side of the magnetic array (203).

[0036] While the first and second magnetic arrays (201) and (203) are shown in FIG. 2A as having regions that each have a length equal to the width of the region, it should be appreciated that in some or all of the regions of the magnetic arrays described here may have a length that is different than the width of the region. For example, in some variations some or all of the regions of a magnetic array may have lengths greater than their widths. In other variations, some or all of the regions of a magnetic array may have lengths shorter than their widths. Additionally, while each of the regions (215) of the first and second magnetic arrays (201) and (203) are shown in FIG. 2A as having the same length, it should be appreciated that different regions may have different lengths.

[0037] The magnetic arrays described here having magnetization patterns may be formed from one or more magnets. For example, in some variations, a magnetic array may comprise a single magnet. In these variations, the magnet may be magnetized such that it has distinct regions with differing polarities. For example, in the some instances, the first magnetic array (201) and/or the second magnetic array (203) may be formed from a single magnet, such that each region of the magnet is magnetized with a specific polarization. In other variations, a magnetic array may comprise a plurality of magnets. In these variations, each region of the array may be formed from a single magnet, or from

multiple magnets. For example, FIG. 2B shows a portion of a first magnetic array (221) and a second magnetic array (223). The first magnetic array (221) is shown as having a first region (225), a second region (227), and a third region (229), wherein each region has a polarity (represented by arrows (237)) that is rotated 90 degrees clockwise relative to that of the immediately preceding region when looking at the magnetization pattern in a proximal-to-distal direction, similar to the magnetization pattern of the first magnetic array (201) described above with respect to FIG. 2A. Similarly, the second magnetic array (223) is shown as having a first region (231), a second region (233), and a third region (235), wherein each region has a polarity that is rotated 90 degrees counter-clockwise relative to that of the immediately preceding region when looking at the magnetization pattern in a proximal-to-distal direction, similar to the magnetization pattern of the second magnetic array (203) described above with respect to FIG. 2A. As shown in FIG. 2B, the first and third regions (225) and (229) of the first magnetic array (221) may each be formed from a single magnet, while the second region (227) may be formed from a plurality of individual magnets (e.g., three magnets, which are labeled in FIG. 2B as (227a), (227b), and (227c)). Similarly, the first and third regions (231) and (235) of the second magnetic array (223) may each be formed from a single magnet, while the second region (233) may be formed from a plurality of individual magnets (e.g., three magnets, which are labeled in FIG. 2B as (233a), (233b), and (233c)). While the second regions (227) and (233) are shown as each comprising three magnets, an individual region may be made up of any suitable number of magnets (e.g., one, two, three, or four or more magnets).

[0038] In the magnetization patterns depicted in FIGS. 2A and 2B above, the polarization of each region is shown as being either parallel or perpendicular to a longitudinal axis of the magnetic array. It should be appreciated, however, that in some variations, the polarities of the regions within a magnetization pattern may be positioned at any suitable angle. For example, in some variations, a magnetic array may comprise a plurality of regions where each region has a polarity that is rotated 90 degrees relative to an immediately preceding region, and wherein the polarity of each region is angled 45 degrees relative to the longitudinal axis of the magnetic array. Additionally, while the magnetic arrays described above have magnetization patterns in which each region has a polarity that is rotated 90 degrees relative to the polarity of an immediately preceding region, it should be appreciated that the angle between adjacent regions may be any

suitable value. For example, in some variations, one or more magnetic arrays may have a magnetization pattern in which there is a 30 degree rotation between the polarities of adjacent regions. FIG. 3A shows one such variation of a pair of magnetic arrays. Shown there are a first magnetic array (301) having a proximal end (305) and a distal end (309) and a second magnetic array (303) having a proximal end (307) and a distal end (311). Each of the arrays may comprise a plurality of regions (315) each having a polarity (indicated by arrows (313)). The first magnetic array (301) may have a magnetization pattern in which the polarity of each region is rotated 30 degrees clockwise from the polarity of an immediately preceding region when looking at the magnetization pattern in a proximal-to-distal direction. Each region (315) of the first magnetic array (301) may produce a magnetic field, but the rotating polarities between adjacent regions may at least partially cancel out the magnetic field produced on the left side of the magnetic array (301) while augmenting the magnetic field produced on the right side of the magnetic array (301). Similarly, the second magnetic array (303) may have a magnetization pattern in which the polarity of each region is rotated 30 degrees counter-clockwise from the polarity of an immediately preceding region when looking at the magnetization pattern in a proximal-to-distal direction. Each region (315) of the second magnetic array (303) may produce a magnetic field, but the rotating polarities between adjacent regions may at least partially cancel out the magnetic field produced on the right side of the magnetic array (303) while augmenting the magnetic field produced on the left side of the magnetic array (303). As mentioned above, the magnetic arrays may be formed from a single magnet (e.g., a single piece of material) which may have regions with different of the magnet with different polarities as discussed above. In these variations, the polarity of the individual regions may be achieved by subjecting the magnet to a complex magnetic field-pattern to set the magnetic pattern of the magnetic arrays.

[0039] For example, in other variations, one or more magnetic arrays may have a magnetization pattern in which there is a 15 degree rotation between the polarities of adjacent regions. FIG. 3B shows one such variation of a pair of magnetic arrays. Shown there are a first magnetic array (321) having a proximal end (325) and a distal end (329) and a second magnetic array (323) having a proximal end (327) and a distal end (331). Each of the arrays may comprise a plurality of regions (335) each having a polarity (indicated by arrows (333)). The first magnetic array (321) may have a magnetization pattern in which the polarity of each region is rotated 15 degrees clockwise from the

polarity of an immediately preceding region when looking at the magnetization pattern in a proximal-to-distal direction. Each region (335) of the first magnetic array (321) may produce a magnetic field, but the rotating polarities between adjacent regions may at least partially cancel out the magnetic field produced on the left side of the magnetic array (321) while augmenting the magnetic field produced on the right side of the magnetic array (321). Similarly, the second magnetic array (323) may have a magnetization pattern in which the polarity of each region is rotated 15 degrees counter-clockwise from the polarity of an immediately preceding region when looking at the magnetization pattern in a proximal-to-distal direction. Each region (335) of the second magnetic array (323) may produce a magnetic field, but the rotating polarities between adjacent regions may at least partially cancel out the magnetic field produced on the right side of the magnetic array (323) while augmenting the magnetic field produced on the left side of the magnetic array (323).

[0040] In still other variations, one or more magnetic arrays may have a magnetization pattern in which there is a 45 degree rotation between the polarities of adjacent regions. FIG. 4 shows one such variation of a pair of magnetic arrays. Shown there are a first magnetic array (401) having a proximal end (405) and a distal end (409) and a second magnetic array (403) having a proximal end (407) and a distal end (411). Each of the arrays may comprise a plurality of regions (415) each having a polarity (indicated by arrows (413)). The first magnetic array (401) may have a magnetization pattern in which the polarity of each region is rotated 45 degrees clockwise from the polarity of an immediately preceding region when looking at the magnetization pattern in a proximal-to-distal direction. Each region (415) of the first magnetic array (401) may produce a magnetic field, but the rotating polarities between adjacent regions may at least partially cancel out the magnetic field produced on the left side of the magnetic array (401) while augmenting the magnetic field produced on the right side of the magnetic array (401). Similarly, the second magnetic array (403) may have a magnetization pattern in which the polarity of each region is rotated 45 degrees counter-clockwise from the polarity of an immediately preceding region when looking at the magnetization pattern in a proximal-to-distal direction. Each region (415) of the second magnetic array (403) may produce a magnetic field, but the rotating polarities between adjacent regions may at least partially cancel out the magnetic field produced on the right side of the magnetic array (403) while augmenting the magnetic field produced on the left side of the magnetic array

(403). As mentioned above, the magnetic arrays shown in FIG. 4 may be each be formed from a single magnet or from a plurality of individual magnetic elements.

[0041] The ability to generate locally concentrated magnetic fields may allow the catheters described here to increase the attractive force between the catheters when the size of the catheters (and the magnetic elements thereof) is otherwise constrained. Because the magnetic elements of the catheters described may be advanced into the body, the patient's anatomy may place constraints on the dimensions of the catheters and the magnetic elements, such as discussed. Accordingly, a magnetic array which generates a local magnetic field may help to maximize the attractive force between two catheters, which may allow the catheters to overcome additional compliance and/or resistance (e.g., by tissue between the vessels) to help bring the catheters into apposition.

[0042] It should be appreciated that although the magnetic arrays discussed above with respect to FIGS. 2A-2B, 3A-3B, and 4 have been described as pairs, a catheter system may utilize any combination of magnetic arrays as described here. For example, when the systems described here comprise a first catheter and a second catheter, either the first and/or second catheter may have one or more magnetic elements that produce a locally-concentrated magnetic field. For example, in some variations, a first catheter of a system may comprise one or more magnetic elements that produce a locally-concentrated magnetic field. The first catheter may include any of the magnetic arrays discussed above with respect to FIGS. 2A-2B, 3A-3B, and 4. The second catheter may also comprise one or more magnetic elements that produce a locally-concentrated magnetic field, but need not. In variations where each of the first and second catheters include one or more magnetic elements that produce a locally-concentrated magnetic field, the catheters may comprise any combination of the magnetic arrays described above with respect to FIGS. 2A-2B, 3A-3B, and 4. For example, in some variations, the first catheter may comprise a first magnetic array having a magnetization pattern having a first angle between the polarities of adjacent regions, and the second catheter may comprise a second magnetic array having a second angle between the polarities of adjacent regions. In some variations, the first angle of the first magnetic array may be a clockwise rotation between adjacent regions in a proximal-to-distal direction, while the second angle of the second magnetic array may be a counter-clockwise rotation between adjacent regions in a proximal-to-distal direction. In other variations, both the first angle of the first magnetic

array and the second angle of the second magnetic array may be a clockwise rotation (or both may be a counter-clockwise rotation) between adjacent regions in a proximal-to-distal direction. The first angle and second angle may be any suitable value, such as described in more detail above, and the first angle may be the same as or different than the second angle.

Magnetic Control Device

[0043] In another embodiment, the systems described may comprise a magnetic control device. This magnetic control device may be positioned externally to the body, and may provide one or more magnetic forces to one or more catheters positioned in the body. Generally, the magnetic control device may comprise a magnet configured to increase the attractive force between two catheters to help bring the catheters toward each other.

[0044] FIGS. 5A and 5B show one embodiment of a magnetic control device as described here. FIG. 5A and 5B depict a perspective view and a cross-sectional perspective view, respectively, of the magnetic control device (501). As shown there, the magnetic control device (501) may comprise a housing (503) having a distal contact surface (505), a magnet (507) moveable relative to the housing (503), and a control element (509) for manipulating the magnet (507). In some variations, the magnetic control device (501) may comprise a spring (521) or other structure configured to bias the magnet (507) toward a specific position, as will be described in more detail below, but need not.

[0045] Generally, the magnet (507) of the magnetic control device (501) may be at least partially housed within the housing (503). The magnet (507) may be moveable relative to the housing (503) (as will be described below), and may be configured to increase the attractive force between two catheters that may be positioned in the body when the magnet (507) is positioned near the catheters. Because the magnet (507) is configured to be positioned external to the body, the magnet (507) may not be subject to the same size constraints as the magnetic elements of the catheters described here.

[0046] The magnet (507) of the magnetic control device may include an arrangement of one or more individual magnets, which may be configured to generate any suitable magnetic field. For example, FIGS. 6A-6B and 7-10 illustrate variations of

magnetic arrangements that may be suitable for use with the magnetic control devices described here. FIG. 6A shows one variation in which a magnetic arrangement (607) may comprise a first magnetic element (609) positioned on a first side of a centerline (610), and a second magnetic element (611) positioned on the other side of the centerline (610) and attached to the first magnetic element (609) such that the polarity (indicated by arrow (615)) of the first magnetic element (609) is opposite the polarity (indicated by arrow (617)) of the second magnetic element (611). The magnetic arrangement (607) may create a magnetic field (represented in FIG. 6A by field lines (619)), which may be configured to pull magnetic elements toward the centerline (610) of the magnetic arrangement (607).

[0047] For example, when a first catheter (601) and a second catheter (603) are positioned in the body beneath the surface of the skin (represented in FIG. 6A as line (613)), the magnetic arrangement (607) may be positioned near the skin (613) such that the centerline (610) passes between the first catheter (601) and the second catheter (603). For example, when the first and second catheters are positioned in a plane substantially parallel to the skin (613), this may include positioning the magnetic arrangement (607) such that the centerline (610) is substantially perpendicular to the skin (613). The first and second catheters (601) and (603) may each comprise one or more magnetic elements (not shown), which may be responsive to the magnetic field produced by the magnetic arrangement (607). For example, in some variations the first and second catheters (601) and (603) include magnetic elements each having a polarity (indicated in FIGS. 6A by arrows (616)) such that the magnetic field produced by the magnetic arrangement (607) may pull each of the first and second catheters (601) and (603) toward the centerline (610). Since the centerline is positioned between the first and second catheters, this may move the catheters toward each other to bring them in closer approximation.

[0048] Each of the first magnetic element (609) and the second magnetic element (611) may be formed from one or more individual magnets. For example, in the variation of the magnetic arrangement (607) depicted in FIG. 6A, the first magnetic element (609) may be formed from a single magnet and the second magnetic element (611) may be formed from a single magnet. In other variations, one or more of the magnetic elements may be formed from multiple individual magnets. For example, FIG. 6B depicts a variation of the magnetic array (607) of FIG. 2A, except that the first magnetic element (609) is formed from three individual magnets (labeled as (609a), (609b), and (609c)) and

the second magnetic element (611) is formed from three individual magnets (labeled as (611a), (611b), (611c)). While each of the first and second magnetic elements is shown in FIG. 2B as being formed from three individual magnets, it should be appreciated that the magnetic elements may be formed from any suitable number of individual magnets (e.g., one, two, three, or four or more magnets).

[0049] The magnetic array (607) may have any suitable dimensions. For example, the magnet array may have any suitable height, such as for example, between about 5 mm and about 25 mm, between about 10 mm and about 20 mm, or the like. Similarly, the array may have any suitable width, such as, for example, between about 5 mm and 35 mm, between about 8 mm and 28 mm, between about 10 mm and about 20 mm, or the like. The array may further have any suitable depth, such as, for example, between about 5mm and about 40mm, about 8mm and about 28mm, between about 10 mm and about 20 mm, or the like. While the variation of magnetic array (607) shown in FIG. 6A has a height that is greater than its width, in some instances the width of magnet (607) may be greater than or equal its height.

[0050] In other embodiments, the magnetic array may have a magnetization pattern which may generate a locally-concentrated magnetic field on one side of the array. For example, FIG. 7 illustrates a magnetic array (707) comprising a centerline (710) and a three-region magnetization pattern. Specifically, the magnetic array (707) may comprise three regions (707a), (707b), (707c), where the polarity (indicated in FIG. 7 by arrows (708)) of each region in magnetic array (707) is rotated ninety degrees relative to adjacent regions. In the variation of the magnetic array (707) shown in FIG. 7, the polarity of the left region (707a) may be in a first direction (e.g., parallel to the centerline (710)), the polarity of the middle region (707b) may be rotated ninety degrees clockwise from that of the left region (707a) (e.g., in a direction perpendicular to the centerline (710)), and the polarity of the right region (707c) may be rotated ninety degrees clockwise from that of the middle region (707b) (e.g., in a direction parallel to the centerline (710), but opposite the first direction). In these variations, the magnetic array (707) may produce a stronger magnetic field on one side of the magnetic array (707) (e.g., the bottom side of the array (707) as shown in FIG. 7) than on an opposite side of the array (707) (e.g., the top side of the array (707) as shown in FIG. 7). The magnetic field created by the magnetic array

(707) may be configured to pull magnetic elements toward the centerline (710) of the magnetic array (707).

[0051] For example, when a first catheter (701) and a second catheter (703) are positioned in the body beneath the surface of the skin (represented in FIG. 7 as line (713)), the magnetic arrangement may be positioned near the skin (713) such that the centerline (710) passes between the first catheter (701) and the second catheter (703). For example, when the first and second catheters are positioned in a plane substantially parallel to the skin (713), this may include positioning the magnetic arrangement (707) such that the centerline is substantially perpendicular to the skin (713). The first and second catheters (701) and (703) may each comprise one or more magnetic elements (not shown), which may be responsive to the magnetic field produced by the magnetic arrangement (707). For example, in some variations the first and second catheters (701) and (703) include magnetic elements each having a polarity (indicated in FIG. 7 by arrows (716)) such that the magnetic field produced by the magnetic arrangement (707) may pull each of the first and second catheters (701) and (703) toward the centerline (710). Since the centerline is positioned between the first and second catheters, this may move the catheters toward each other to bring them in closer approximation. The magnetic array (707) may have any suitable dimensions, such as those described above with respect to the magnetic array (607) of FIGS. 6A and 6B.

[0052] In the magnetic array (707) shown in FIG. 7, the magnetic array may be formed from one or more magnets. In some instances, the magnetic array (707) may be formed from a single magnet such that the regions (707a), (707b), (707c) are portions of the same magnet having different polarities. In some variations, one or more of the regions (707a), (707b), (707c) may be formed by one or more separate magnets. In some of these variations, each of the regions is formed from one or more separate magnets. When a specific region is formed from one or more separate magnets, it should be appreciated that the region may be formed from a single magnet, or may be formed from a plurality of magnets, such as described in more detail above. Additionally, while only three regions are shown in the magnetic array (707), the magnetic array (707) may include any number of regions, wherein each region has a polarity that is rotated 90 degrees clockwise relative to a polarity of the adjacent region to its left.

[0053] While the polarities in adjacent regions of the magnetic array (707) are rotated by 90 degrees, it should be appreciated that the magnetic arrays described here may have magnetization patterns in which adjacent regions have polarizations that are rotated any suitable angle (e.g., about 15 degrees, about 30 degrees, about 45 degrees, about 60 degrees or the like). For example, FIG. 8 shows one variation of a magnetic array (807) comprising five regions (807a), (807b), (807c), (807d), (807e), wherein each region is rotated forty-five degrees clockwise relative to the region on its left (when viewed from the orientation shown in FIG. 8). In these variations, the magnetic array (807) may produce a stronger magnetic field on one side of the magnetic array (807) (e.g., the bottom side of the array (807) as shown in FIG. 8) than on an opposite side of the array (807) (e.g., the top side of the array (807) as shown in FIG. 8). The magnetic field created by the magnetic array (807) may be configured to pull magnetic elements toward a centerline (810) of the magnetic array (807).

[0054] In instances when the two catheters positioned in the body lie in a plane that is substantially perpendicular to the surface of the skin, it may be difficult to position an external magnet such that a centerline of the magnet passes between the catheters. Accordingly, some of the magnets suitable for use with the magnetic control devices described here may be configured to bring the magnets in closer approximation when the catheters are aligned substantially perpendicular to a skin surface. For example, FIG. 9 shows a magnet (907) comprising a single polarity (indicated in FIG. 9 by arrows (915)), which may be configured to increase the attractive force between a first catheter (901) and a second catheter (903) that are positioned in a plane (910) that is substantially perpendicular to the skin surface (913). In these variations, the magnet (907) may be positioned near the skin surface (913) such that the direction of the polarity (915) of the magnet (907) is aligned with the plane (910) of the first and second catheters. In these instances, the magnet (907) may generate a magnetic field that may repulse the first and second catheters. Since the first catheter (901) is positioned closer to the magnet (907) than the second catheter (903), the force applied by the magnet (907) to the first catheter may be greater than the force applied by the magnet to the second catheter, which may cause the first catheter to move toward the second catheter. In other instances, the magnet (907) may be configured to attract both the first (901) and second catheter (903) toward the skin. Since the first catheter (901) is positioned closer to the skin, the tissue around the skin may provide greater resistance to movement toward than magnet than may be felt

by the second catheter (903), which may draw the second catheter (903) toward the first catheter (901).

[0055] FIG. 10 illustrates another variation of a magnetic array (1007) configured to increase the attractive force between two catheters aligned substantially perpendicular to a skin surface. As shown there, the magnetic array (1007) may comprise a magnetization pattern comprising three regions (1007a), (1007b), (1007c), where the polarity of each region in magnetic array (1007) is rotated ninety degrees clockwise relative to the region on its left (when viewed from the orientation shown in FIG. 10). That is, the first region (1007a) may have a polarity in a first direction (e.g., to the left in the orientation shown in FIG. 10), the second region (1007b) may have a polarity that is rotated ninety degrees clockwise from the polarity of the first region (1007a) (e.g., toward the top of the magnet (1007) in the orientation shown in FIG. 10), and the third region (1007c) may have a polarity that is rotated ninety degrees from the polarity of the second region (1007b) (e.g., toward the right in the orientation shown in FIG. 10). In these variations, the rotating polarities of the regions may augment the magnetic field provided by a first side of the magnetic array (1007) (e.g., the bottom side in the orientation shown in FIG. 10), which may be configured to increase the attractive force between a first catheter (1001) and a second catheter (1003) that are positioned in a plane (1010) that is substantially perpendicular a skin surface (1013). In these variations, the magnet (1007) may be positioned near the skin (1013) such that the direction of the polarity of the second region (1007b) is aligned with the plane (1010) of the first and second catheters. In these instances, the magnetic array (1007) may generate a magnetic field that may repulse the first and second catheters. Since the first catheter (1001) is positioned closer to the magnetic array (1007) than the second catheter (1003), the force applied by the magnetic array (1007) to the first catheter may be greater than the force applied by the magnet to the second catheter, which may cause the first catheter to move toward the second catheter. In other variations, the magnetic array (1007) may be configured attract both the first (1001) and second (1003) catheters toward the skin of the patient, which may draw the second catheter (1003) toward the first catheter (1001) as discussed above with respect to the magnetic array (907) of FIG. 9. The individual regions of the magnetic array (1007) may be formed from one or more individual magnets, such as described in more detail above.

[0056] As with the magnetic arrays discussed above, the magnetic arrays (907) and (1007) shown in FIGS. 9 and 10 respectively may have any suitable dimensions, and specifically may have any suitable height (e.g., between about 5mm and about 160mm, between about 10 mm and about 150mm, between about 20 mm and about 140mm, between about 40 mm and about 120mm, between about 75 mm and about 85mm, etc.), width (e.g., between about 5 mm and about 50mm, between about 10 mm and about 40mm, between about 18 mm and about 25mm), and depth (e.g., between about 5 mm and about 50mm, between about 10 mm and about 40mm, between about 18 mm and about 25mm) While the variation of magnet (907) shown in FIG. 9 has a height that is greater than its width, in some instances the width of magnet (907) may be greater than its height.

[0057] Returning to FIGS. 5A and 5B, the magnetic control device (501) may comprise, in addition to the magnet (507), a housing (503) having a contact surface (505) a distal end of the housing that is configured to be placed against the skin. The housing (503) may at least partially house the magnet (507), and the magnet (507) may be moveable relative to the contact surface (505) of the housing to adjust the distance between the magnet (507) and the contact surface (505). In use, the contact surface (505) may be placed against a skin surface, and may act as a stop which may limit movement of one or more catheters or tissue relative to the magnet (507), as will be described in more detail below. The contact surface (505) may be formed from one or more rigid materials (e.g., a hard plastic or the like) or may be formed from one or more flexible materials.

[0058] As mentioned above, the magnetic control device (501) may comprise a control element (509) configured to selectively move the magnet (507) relative to the housing (503) and the contact surface (505). Specifically, the magnet (507) may be fixed to the control element (509) (e.g., via one or more adhesives, bonding, welding or the like), and the control element (509) may comprise a slider that is slidably connected to the housing (503). The control element (509) may be advanced toward the contact surface (505) to move the magnet (507) toward the contact surface (505), and may be withdrawn away from the contact surface (505) to move the magnet (507) away from the contact surface (505). It should be appreciated that while shown in FIGS. 5A and 5B as comprising a slider, the control element (509) may be any element or combination of elements capable of moving the magnet (507) relative to the contact surface (505), such as, for example, one or more knobs, triggers, cranks, levers, or the like. For instance, in

one variation the control element may have a stapler-like configuration or a squeeze grip having two members connected by a pivot joint. When an operator compresses the stapler-like configuration or squeeze grip by pressing the members toward each other, the magnet may be moved closer to the contact surface. It should also be appreciated that in some embodiments, the magnet may be fixed relative to the contact surface of the magnetic control device.

[0059] In some variations, the magnetic control device (501) may comprise a spring (521) configured to bias the control element (509) away from the contact surface (505). In these variations, a user may apply a force to the control element (509) to overcome the bias provided by the spring (521) and advance the control element (509) and magnet (507) toward the contact surface (505). When the force is released, the spring (521) may return the control element (509) and magnet (507) to their original positions. Additionally or alternatively, the magnetic control device (501) may comprise one or more mechanisms configured to temporarily maintain a position of the control element (509). For example, in some variations the housing may comprise a series of teeth (not shown) which may be configured to allow one-way movement of the control element (509) relative to the teeth. In this variation, the teeth may engage the control element (509) and/or the magnet (507) such that the control element (509) may move incrementally toward the contact surface (505), but may be prevented from moving away from the contact surface (505). Each incremental advancement may create an audible sound as the control element (509) and/or magnet (507) advances beyond each individual tooth, which may provide feedback to the user. The teeth may also be moveable to release the engagement between the teeth and the control element (509) and/or magnet (507), which may allow for retraction of the control element (509) and magnet (507) relative to the contact surface (505). In variations where the magnetic control device (501) comprises a spring (521) as shown in FIGS. 5A and 5B, the spring (521) may return the control element (509) and magnet (507) to their original positions when the teeth are disengaged from the control element (509) and/or magnet (507).

[0060] The housing and/or control element may have one or more grips or finger rings configured to help allow a user to grab or hold the housing and/or control elements, which may allow for an intuitive and ergonomic user interface, and in some instances may allow the magnetic control device (501) to be manipulated with a single hand. For

example, in the embodiment shown in FIGS. 5A and 5B, the housing (503) may comprise two finger rings (513), and the control element (509) may comprise a finger ring (519) such that the finger rings may allow a user to grip the magnetic control device (501) in a syringe-like fashion. For example, a user may place one or more fingers in one or more of the finger rings (513) of the housing (503) and may place a thumb in the finger ring (519) of the control element (509), and may “squeeze” the finger ring (519) of the control element (509) toward the finger rings (513) of the housing (503) to advance the control element (509) (and with it, the magnet (507)) toward the contact surface (505). While the housing (503) is shown in FIGS. 5A and 5B as having two finger rings, it should be appreciated that the housing need not have any finger rings (519), may have one finger ring, or may have three or more finger rings.

[0061] In some variations, the magnetic control device may comprise one or more elements configured to releasably secure the magnetic control device to the body. For example, in some variations the magnetic control device may comprise one or more straps (e.g., an elastic strap or the like) which may be connected to the housing, such that the strap may be positioned around a limb (e.g., an arm) of a patient to temporarily connect the magnetic control device to the limb, which may allow the magnetic control device to remain in place without needing to be held by a user.

Systems

[0062] Also described here are systems for forming a fistula between two blood vessels. Generally, the systems may comprise a first catheter, which may comprise one or more fistula-forming elements and one or more magnetic elements. The first catheter may comprise any one or more of any of the fistula-forming elements or combination of fistula-forming elements as described in more detail above and in U.S. Patent Application Serial No. 13/298,169, which was previously incorporated by reference in its entirety. The first catheter may comprise one or more magnetic elements, which may be any of the magnetic elements described in more detail above. In some variations, the magnetic element may be a permanent magnet or electromagnet generating a locally concentrated magnetic flux, or it may be a ferromagnetic material which may be temporarily magnetized in the presence of a magnetic field. The first catheter may comprise any suitable catheter body and may comprise one or more other elements, such as one or more shape-changing elements or balloons such as described in more detail in U.S. Patent

Application Serial No. 13/298,169, which was previously incorporated by reference in its entirety.

[0063] The systems described here may also comprise a second catheter. In some variations, the second catheter may comprise a fistula-forming element and one or more magnetic elements, but need not. In variations where the second catheter does comprise a fistula-forming element, the second catheter may comprise any one or more of any of the fistula-forming elements or combination of fistula-forming elements as described in more detail above and in U.S. Patent Application Serial No. 13/298,169, which was previously incorporated by reference in its entirety. The fistula-forming element of the second catheter may be the same as or different from the fistula-forming element of the first catheter. The second catheter may comprise one or more magnetic elements, which may be any of the magnetic elements described in more detail above. In some variations, the magnetic element may be a permanent magnet or electromagnet generating a locally concentrated magnetic flux, or it may be a ferromagnetic material that may be temporarily magnetized in the presence of a magnetic field. The first catheter may comprise any suitable catheter body and may comprise one or more other elements, such as one or more shape-changing elements or balloons such as described in more detail in U.S. Patent Application Serial No. 13/298,169, which was previously incorporated by reference in its entirety.

[0064] The systems described here may further comprise a magnetic control device, such as described in more detail above which can be used to control one or more magnetic elements of the first and/or second catheters from a position external to the body. The magnetic control device may comprise any elements or combinations of elements as described in more detail above.

Methods

[0065] Also described here are methods for creating a fistula between two blood vessels. The two blood vessels may be two closely-associated blood vessels, such as a vein and an artery, two veins, etc. Generally, in these methods one or more fistula-forming elements may be activated to bore through, perforate, or otherwise create a passageway between the two blood vessels such that blood may flow directly between the two adjoining blood vessels. When such a fistula is formed, hemostasis may be created

without the need for a separate device or structure (e.g., a suture, stent, shunt, or the like) connecting or joining the blood vessels.

[0066] Generally, the methods described here comprise accessing a first blood vessel with a first catheter, and advancing the first catheter to a target location within a blood vessel. A second blood vessel may be accessed with a second catheter, and the second catheter may be advanced to a target location within the second vessel. In some of these methods, a first catheter may be advanced into an artery, and a second catheter is advanced into a vein. In other methods, a first catheter may be advanced into a first vein and a second catheter is advanced into a second vein. In yet other methods, a first catheter may be advanced into a first artery and a second catheter is advanced into a second artery. The catheters may be advanced in any suitable manner, as described in more detail in U.S. Patent Application Serial No. 13/298,169, which was previously incorporated by reference in its entirety, and any of the catheters described in that application may be used.

[0067] Once the first and/or second catheters have been advanced into the respective blood vessels, the catheters may be adjusted to affect the positioning of the catheters within the blood vessels and/or the positioning of the blood vessels relative to each other. In variations where a first catheter has been advanced into a first blood vessel and a second catheter has been advanced into a second blood vessel, the first and second catheters may be adjusted to bring at least a portion of the first and second catheters toward each other, which may act to bring the blood vessels in closer approximation. Adjusting the catheters may comprise using one or more magnetic alignment elements, shape-changing members, markers, or balloons or expandable members, as described in more detail in U.S. Patent Application Serial No. 13/298,169, which was previously incorporated by reference in its entirety.

[0068] In variations where the first and second catheters comprise one or more magnetic elements, the magnetic elements may result in an attractive force between the first and second catheters, which may pull the catheters toward each other. For example, the first and/or second catheters may comprise one or more magnetic elements having a magnetization pattern such as described in more detail above. Additionally or alternatively, a magnet may be positioned externally to the body and may act to bring the first catheter closer to the second catheter. For example, FIGS. 11A-11C depict a method by which the magnetic control device (501) described above with respect to FIGS.

5A and 5B may be used to bring a first catheter towards a second catheter. For example, a first catheter (1101) may be placed in a first blood vessel (not shown) and a second catheter (1103) may be placed in a second blood vessel (not shown), such as shown in FIG. 11A. The magnetic control device (501) may be positioned to place the contact surface (505) against the skin surface (1113) of a patient near the first and second catheters, such as shown in FIG. 11A. In variations in which the magnetic control device (501) comprises a securing element, the securing element may be used to secure the magnetic control device (501) to the patient.

[0069] The magnet (507) may be configured to generate a magnetic field configured to move the first catheter (1101) toward the second catheter (1103), such as described in more detail above. Specifically, the magnet (507) may be advanced (e.g., using a control element (509) as discussed above) toward the contact surface (505) from a retracted position (as shown in FIG. 11A) to an extended position (as shown in FIG. 11B). As the magnet (507) approaches the extended position, the distance between the magnet (507) and the first and second catheters may decrease. This in turn may increase the magnitude of the force that the magnet (507) applies to the first and second catheters. As the force applied to the first and second catheters is increased, the first and second catheters may be urged together, as shown in FIG. 11B.

[0070] Once the first and second catheters (1101) and (1103) have moved into closer proximity, the magnet (507) can be moved away from contact surface (505) (e.g., by retracting a control element (509), allowing the spring-bias provided by spring (521) to retract the control element (509), etc.) to move the magnet (507) away from the catheters (1101) and (1103), such as shown in FIG. 11C. When the magnet (507) applies an attractive force to the first and/or second catheters, movement of the magnet (507) away from the skin surface (1113) may pull the first and/or second catheters toward skin surface (1113). In these instances, the contact surface (505) may act as a stop to push against the skin surface (1113) and limit tissue movement towards housing (503) as the magnet (507) is retracted (which may in turn reduce the likelihood that the first and/or second catheters may damage tissue by being pulled toward the skin surface (1113)). With the magnet (507) withdrawn, the magnetic control device (501) may be removed from its position relative to the skin surface (1113). The magnetic control device (501) may be removed before, during, or after fistula formation.

[0071] Once the catheter or catheters have been positioned and adjusted, one or more fistula-forming elements may be used to create a fistula between the two blood vessels. For example, in some variations, one of the first and second catheters comprises a fistula-forming element (e.g., an electrode, a cutting blade, or the like), while the other catheter does not comprise a fistula-forming element. In other variations, both catheters comprise a fistula-forming element. In some of these variations, the fistula-forming elements of the first and second catheters act to form different fistulas. In other variations, the fistula-forming elements of the first and second catheters interact to form the same fistula. For example, in some variations the first and second catheters each comprise at least one electrode. Any of the methods for using fistula-forming elements to create one or more fistulas described in U.S. Patent Application Serial No. 13/298,169, which was previously incorporated by reference in its entirety, may be used. Additionally, one or more balloons may be used to modify a fistula after the fistula has been formed, to affect the blood flow relative to the fistula, or to determine that the fistula has been properly formed, as described in more detail in U.S. Patent Application Serial No. 13/298,169, which was previously incorporated by reference in its entirety.

CLAIMS

We claim:

1. A system for creating a fistula between two vessels, comprising:

a first catheter comprising a first magnetic element; and

a second catheter comprising a second magnetic element;

wherein at least one of the first and second catheters comprises a fistula-forming element, and

wherein the first magnetic element is configured to produce a magnetic field that is stronger on a first side of the first magnetic element than on a second side of the first magnetic element.
2. The system of claim 1 wherein the fistula-forming element is an electrode.
3. The system of claim 1 wherein the first magnetic element comprises a plurality of regions each having a polarity, and wherein the plurality of regions of the first magnetic element is configured such that the polarity of each region is rotated a first angle relative to the polarity of an immediately-preceding region in a proximal-to-distal direction.
4. The system of claim 3, wherein the second magnetic element comprises a plurality of regions each having a polarity, and wherein the plurality of regions of the second magnetic element is configured such that the polarity of each region is rotated a second angle relative to the polarity of an immediately-preceding region proximal-to-distal direction.
5. The system of claim 4 wherein the first angle is the same as the second angle.
6. The system of claim 4 wherein the first angle is about 90 degrees.
7. The system of claim 4 wherein the first angle is about 45 degrees.
8. The system of claim 4 wherein the first angle is about 30 degrees.

9. The system of claim 4, wherein the plurality of regions of the first magnetic element is configured such that the polarity of each region is rotated a first angle clockwise relative to the polarity of an immediately-preceding region in a proximal-to-distal direction, and wherein the plurality of regions of the second magnetic element is configured such that the polarity of each region is rotated a second angle counter-clockwise relative to the polarity of an immediately-preceding region proximal-to-distal direction.
10. A device for applying a magnetic field to a portion of the body, comprising:
 - a housing;
 - a magnet, wherein the magnet is moveable relative to the housing; and
 - a control element fixedly connected to the magnet and moveably connected to the housing, wherein movement of the control element moves the magnet relative to the housing.
11. The device of claim 10 wherein the magnet comprise a magnetic array having a magnetization pattern.
12. The device of claim 10 wherein the housing further comprises one or more finger rings.
13. The device of claim 12 wherein the control element further comprises one or more finger rings.
14. The device of claim 10 wherein the housing comprises a contact surface for placement against the skin and wherein movement of the control element moves the magnet relative to the contact surface.
15. A system for forming a fistula between two vessels, comprising:
 - a first catheter comprising a first magnetic element;
 - a second catheter comprising a second magnetic element, wherein at least one of the first and second catheters comprises a fistula-forming element; and
 - a device for applying a magnetic field to the first and second magnetic elements, comprising a magnet inside a housing, wherein the magnet is moveable within the housing, and wherein the magnet is configured to generate a magnetic field that, when

applied simultaneously to the first and second magnetic elements, is capable of increasing an attractive force between the first and second magnetic elements.

16. The system of claim 15, wherein the fistula-forming element comprises an electrode.
17. The system of claim 15, wherein the first magnetic element comprises a plurality of regions each having a polarity, and wherein the plurality of regions of the first magnetic element is configured such that the polarity of each region is rotated a first angle relative to the polarity of an immediately-preceding region in a proximal-to-distal direction.
18. The system of claim 17, wherein the second magnetic element comprises a plurality of regions each having a polarity, and wherein the plurality of regions of the second magnetic element is configured such that the polarity of each region is rotated a second angle relative to the polarity of an immediately-preceding region proximal-to-distal direction.
19. A method of forming a fistula between a first blood vessel and a second blood vessel of a patient comprising:
 - advancing a first catheter into the first blood vessel, wherein the first catheter comprises first magnetic element;
 - advancing a second catheter into the second blood vessel, wherein the second catheter comprises a second magnetic element, and wherein at least one of the first and second catheters comprises a fistula-forming element;
 - positioning an external magnet external the patient, wherein the magnet produces a magnetic field;
 - moving the first catheter toward the second catheter using the magnetic field produced by the external magnet; and
 - forming a fistula with the fistula-forming element.
20. The method of claim 19, wherein the positioning an external magnet external to the body comprises positioning the external magnet using a magnetic control device, wherein the magnetic device comprises the external magnet and a housing having a contact surface.

21. The method of claim 20 further comprising positioning the contact surface of the housing in contact with a skin surface of the patient.
22. The method of claim 20 further comprising moving the external magnet toward the contact surface to increase a force applied by the magnetic field to at least one of the first and second catheters.
23. The method of claim 19, wherein the fistula-forming element is an electrode, and wherein forming the fistula with the fistula-forming element comprises ablating tissue with the electrode.
24. The method of claim 19, wherein the first blood vessel is a vein and the second blood vessel is an artery.

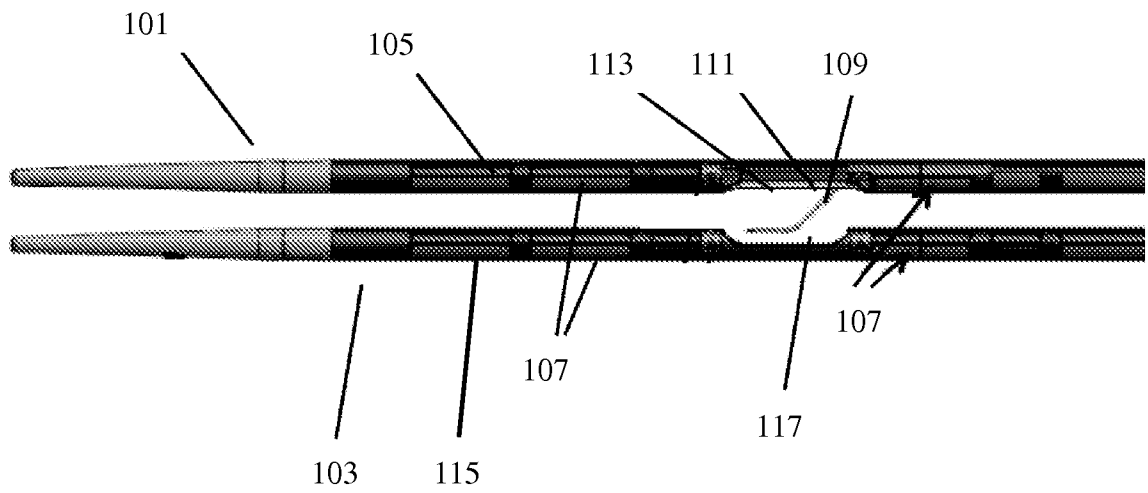

FIG. 1

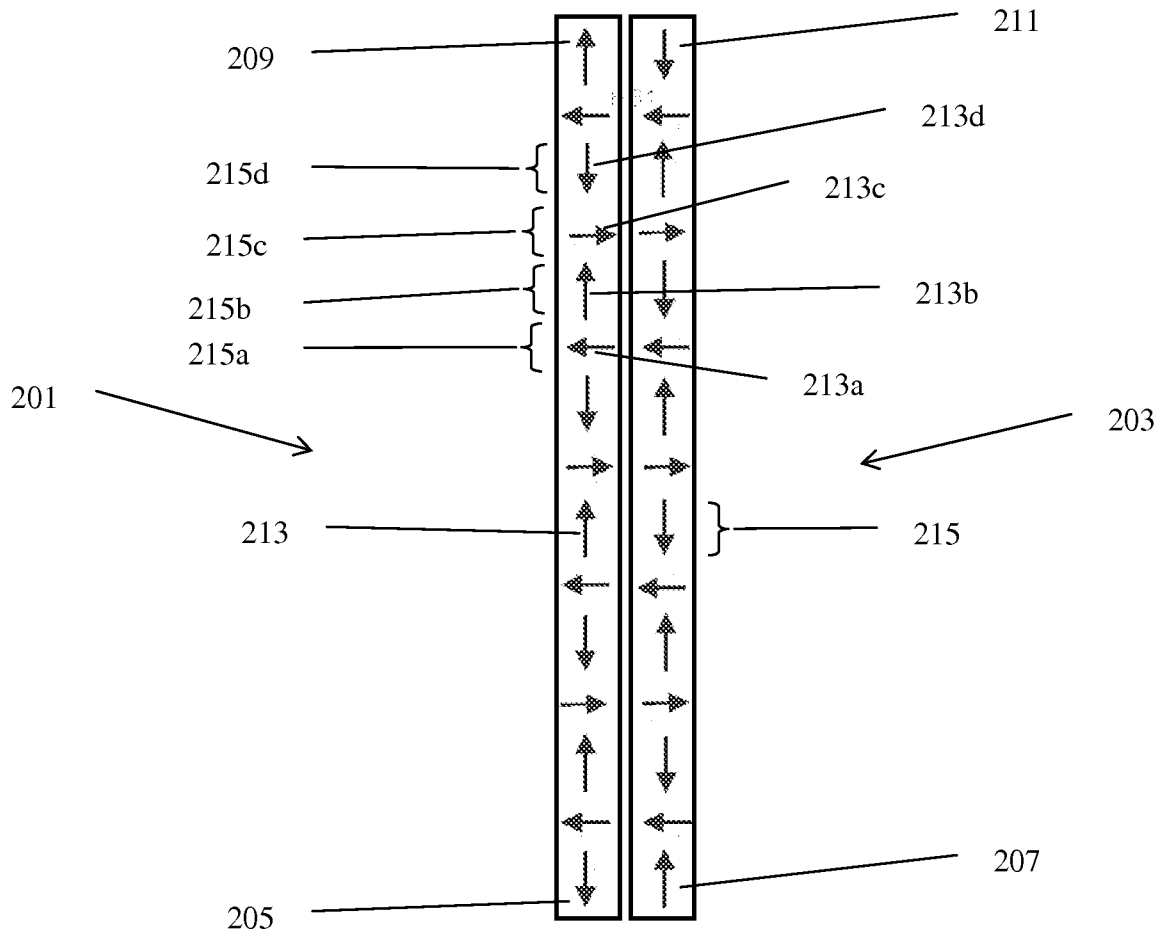

FIG. 2A

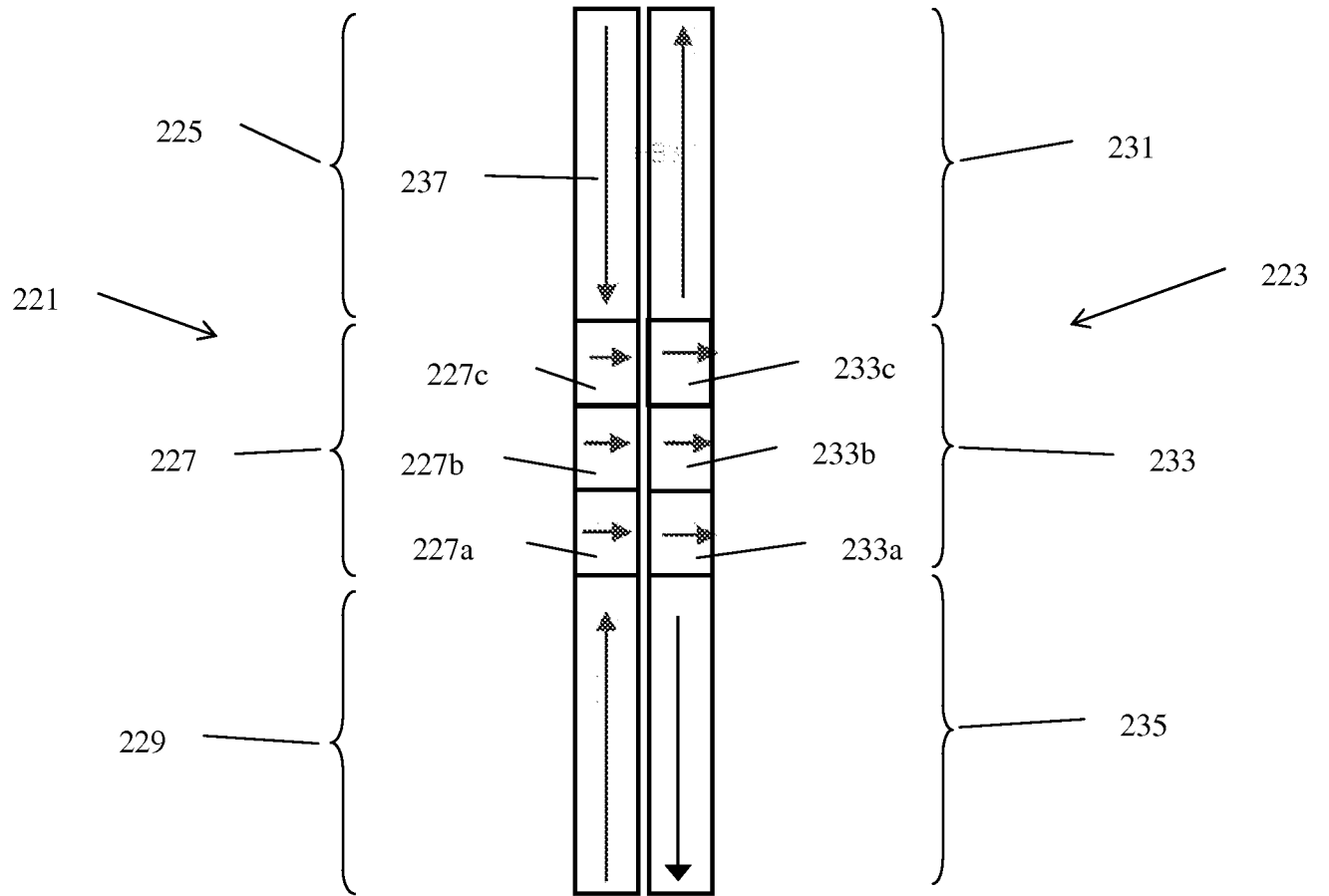

FIG. 2B

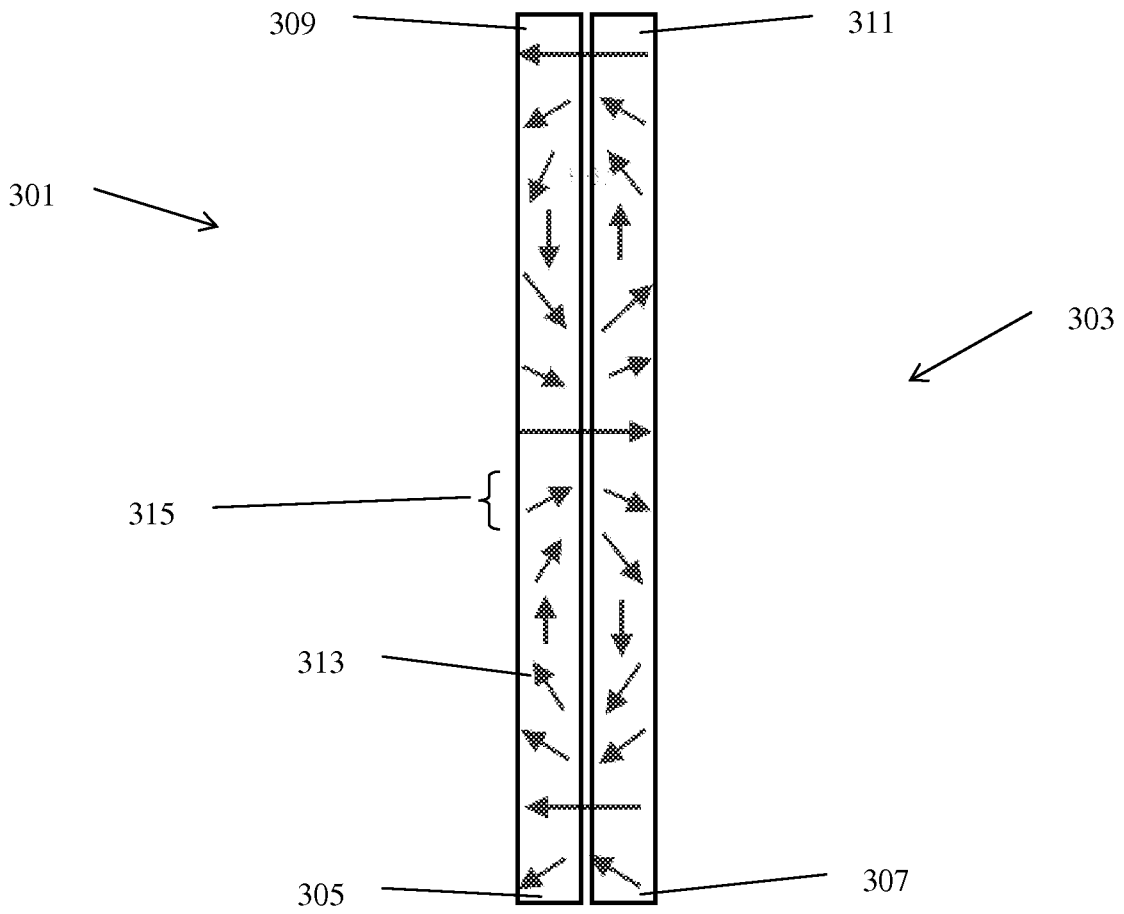

FIG. 3A

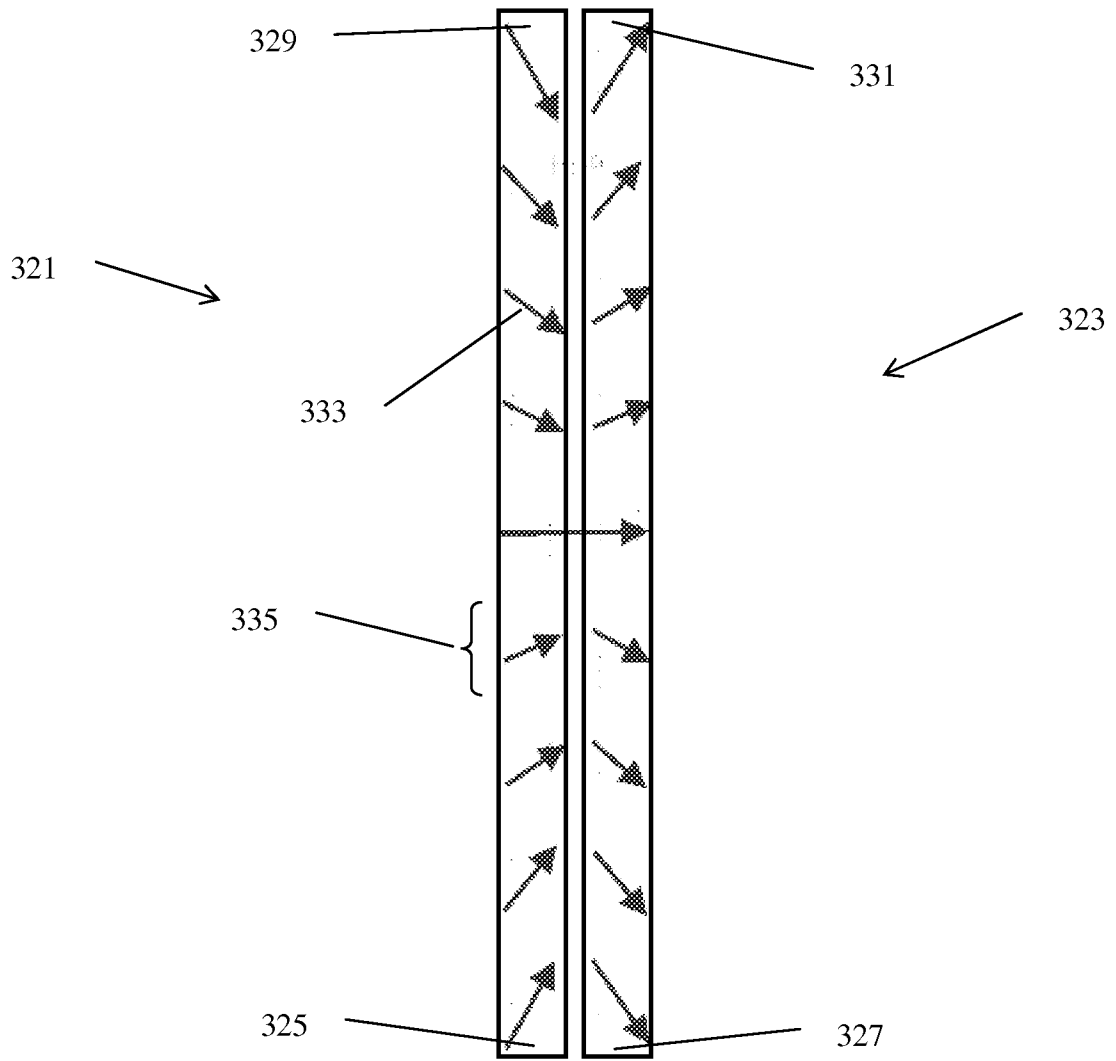

FIG. 3B

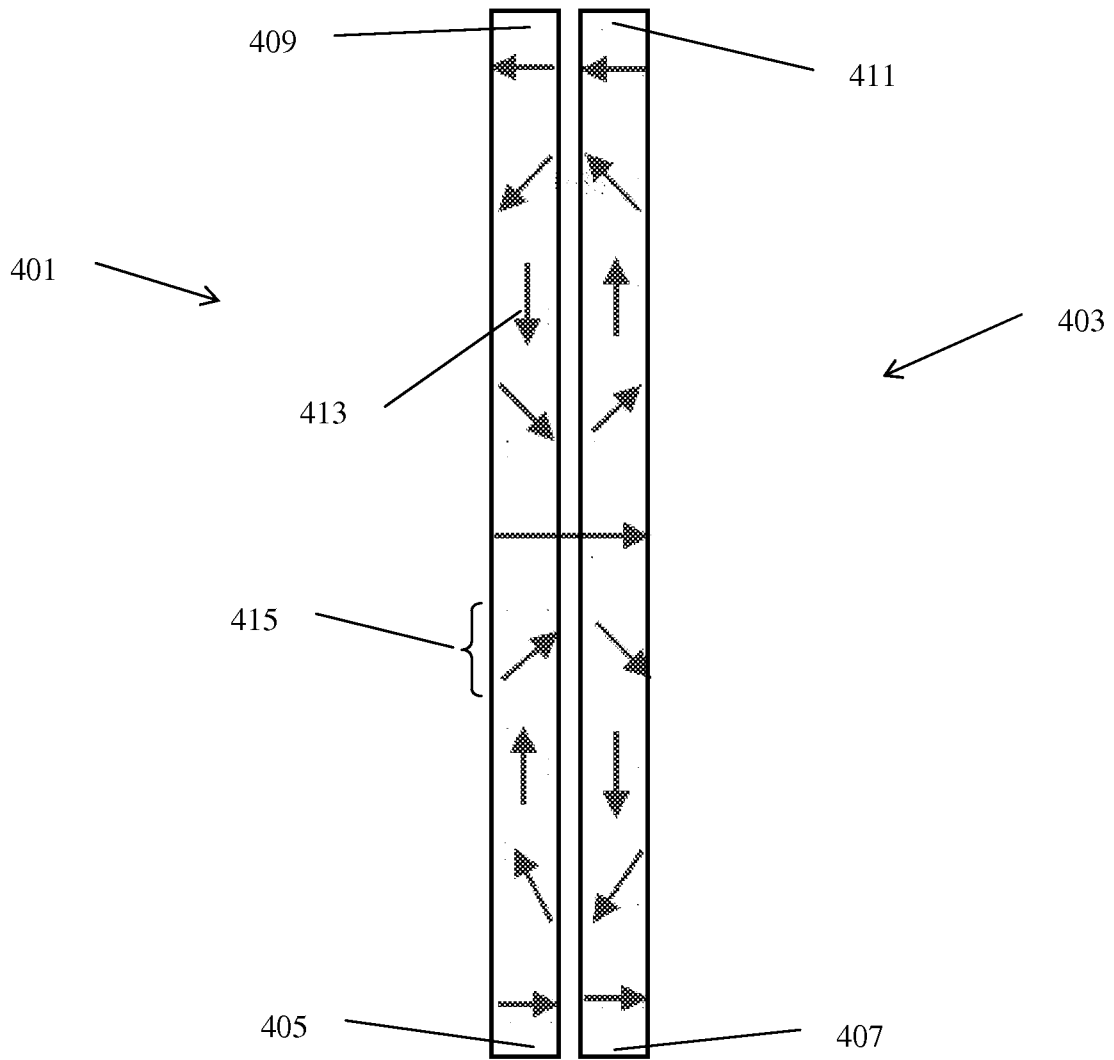

FIG. 4

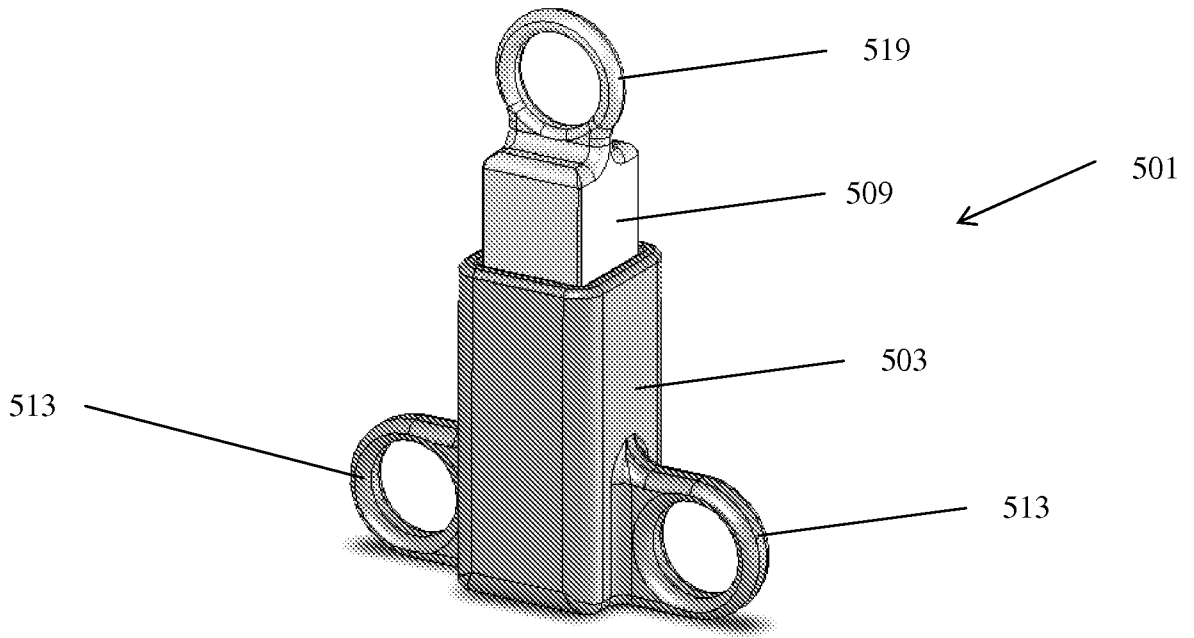

FIG. 5A

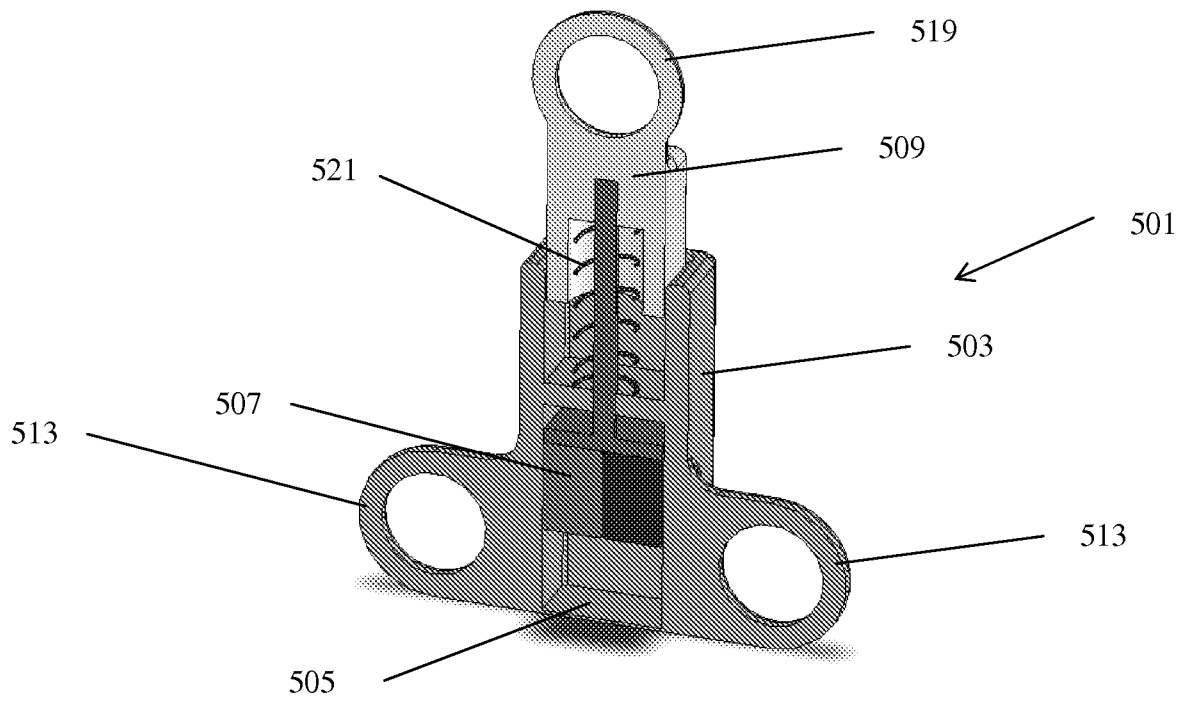
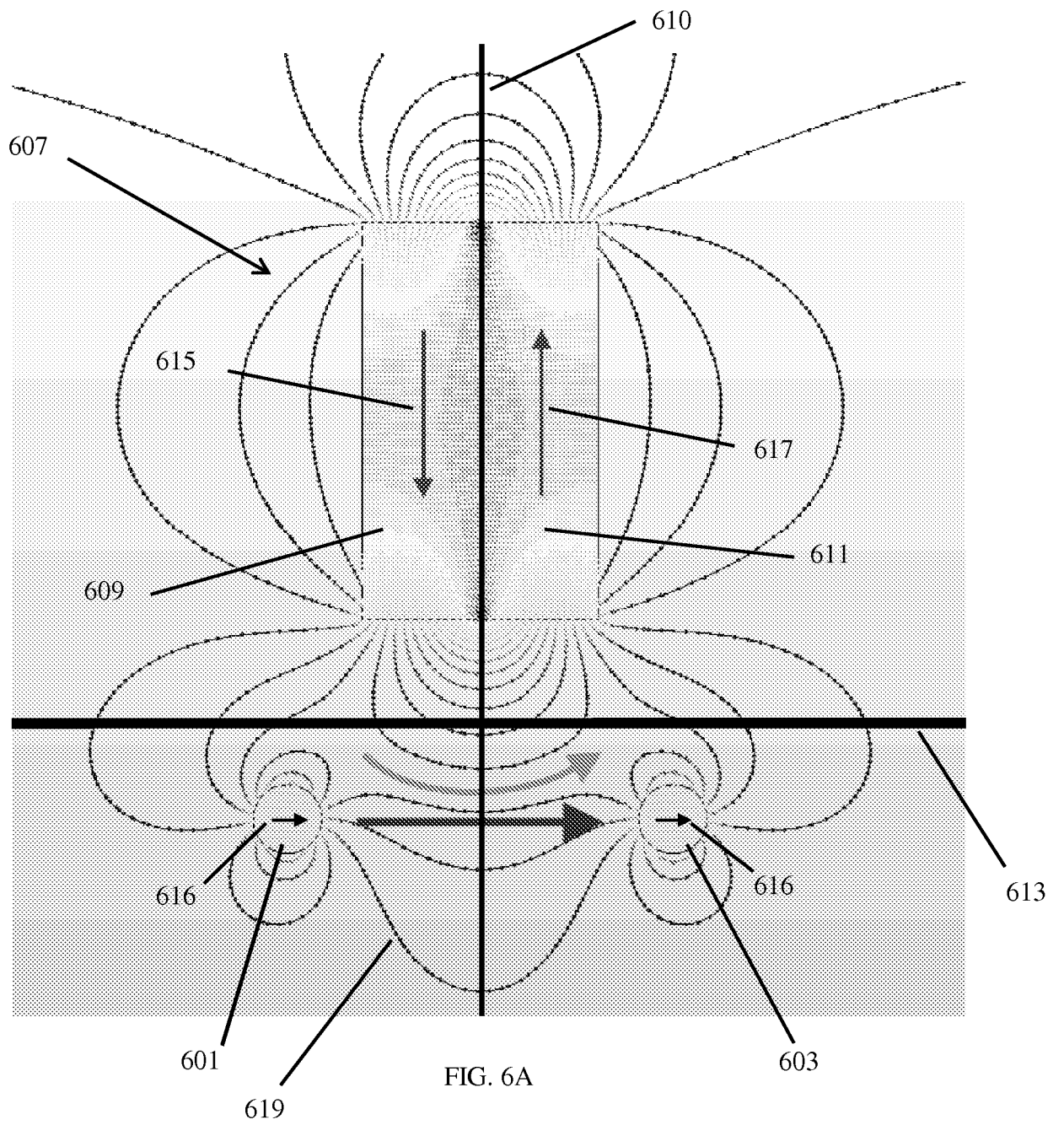

FIG. 5B



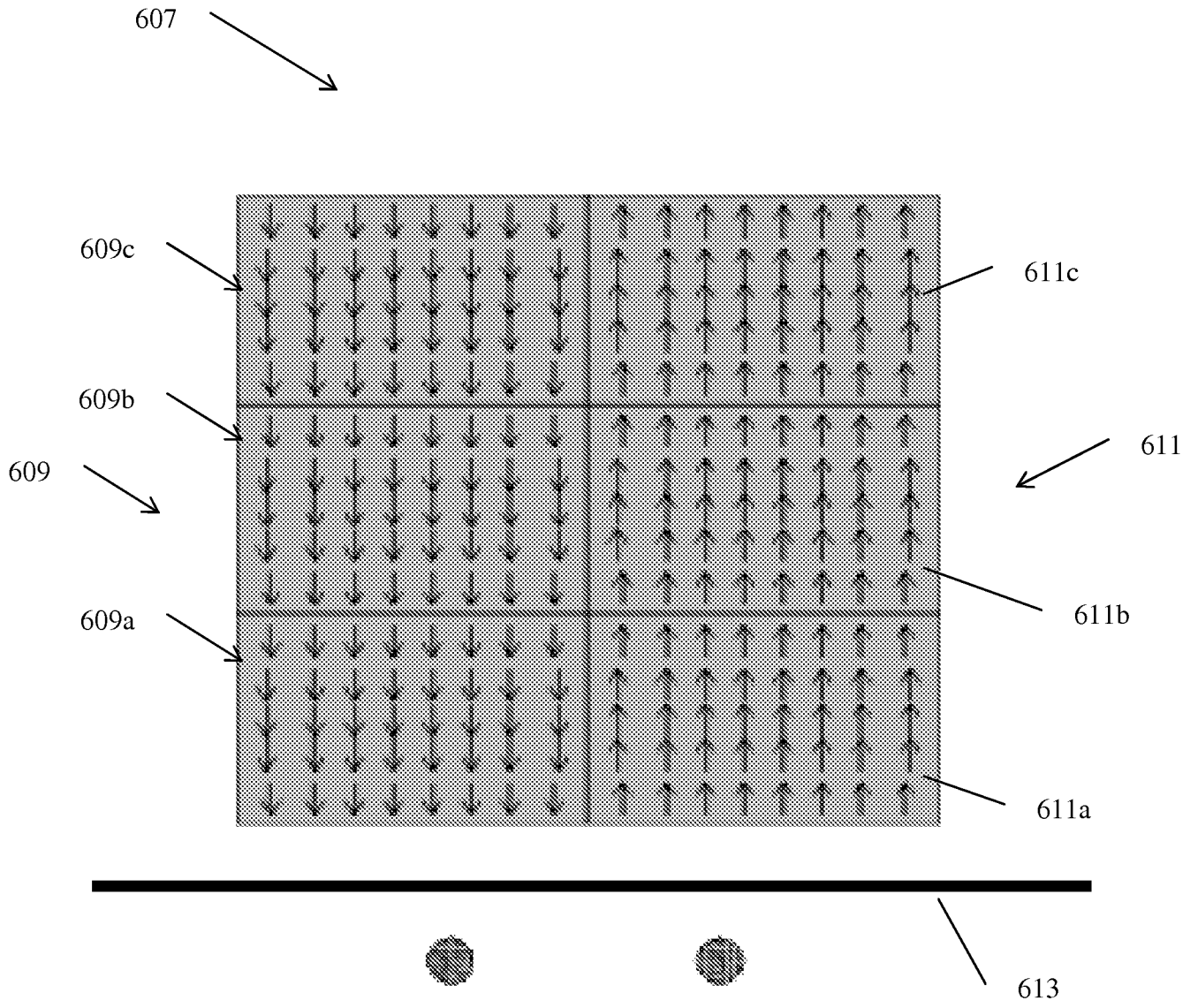

FIG. 6B

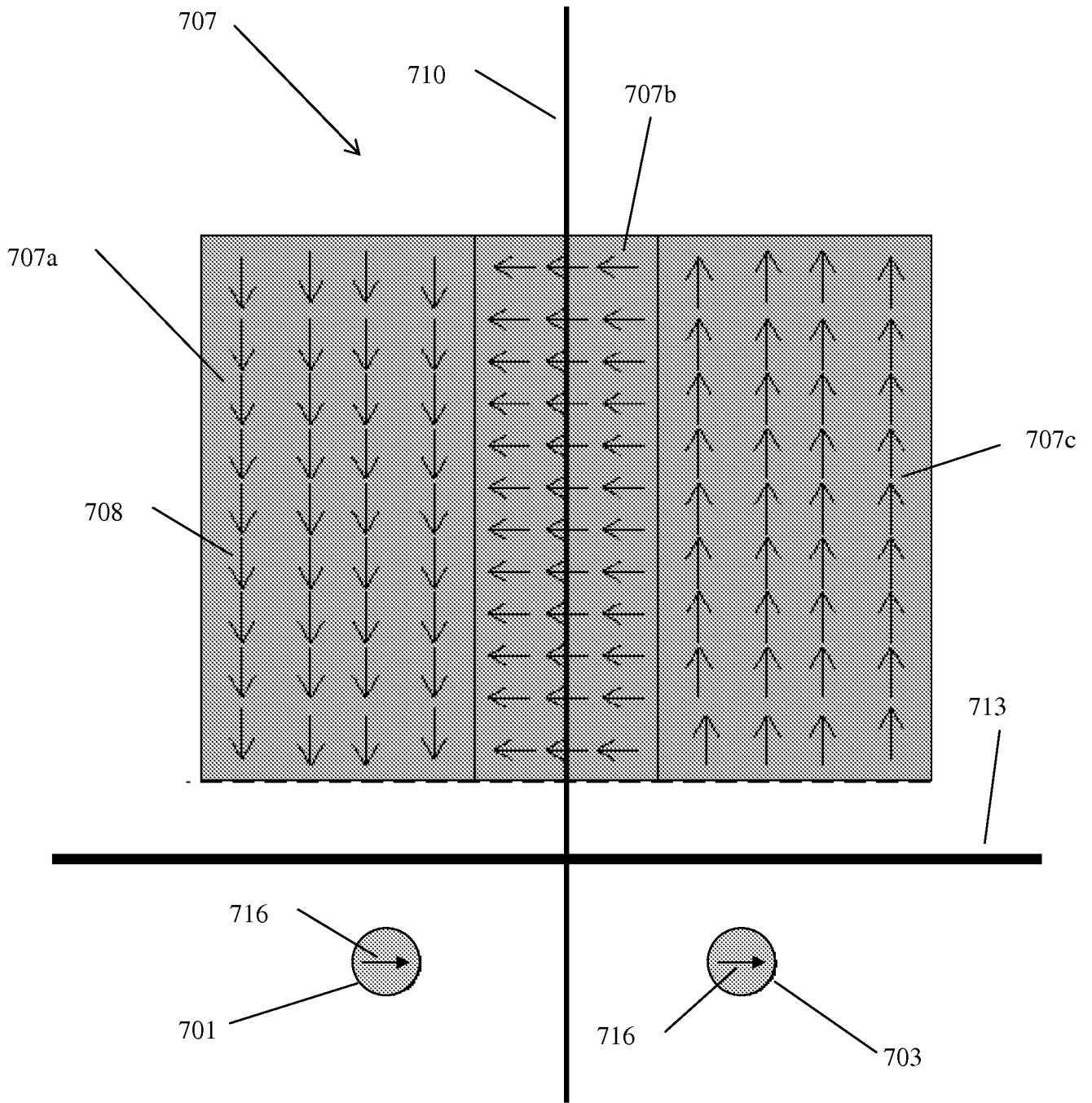

FIG. 7

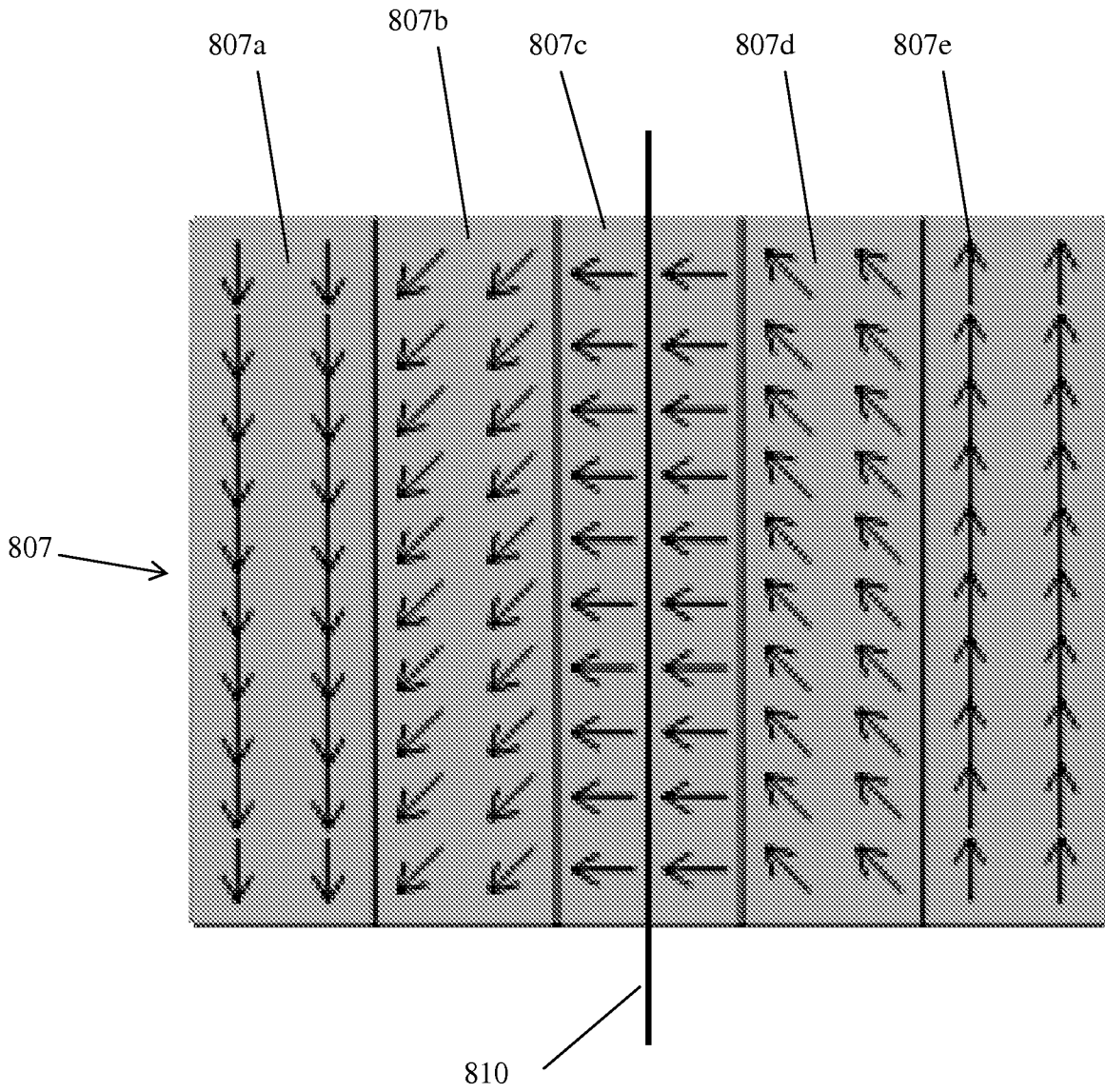

FIG. 8

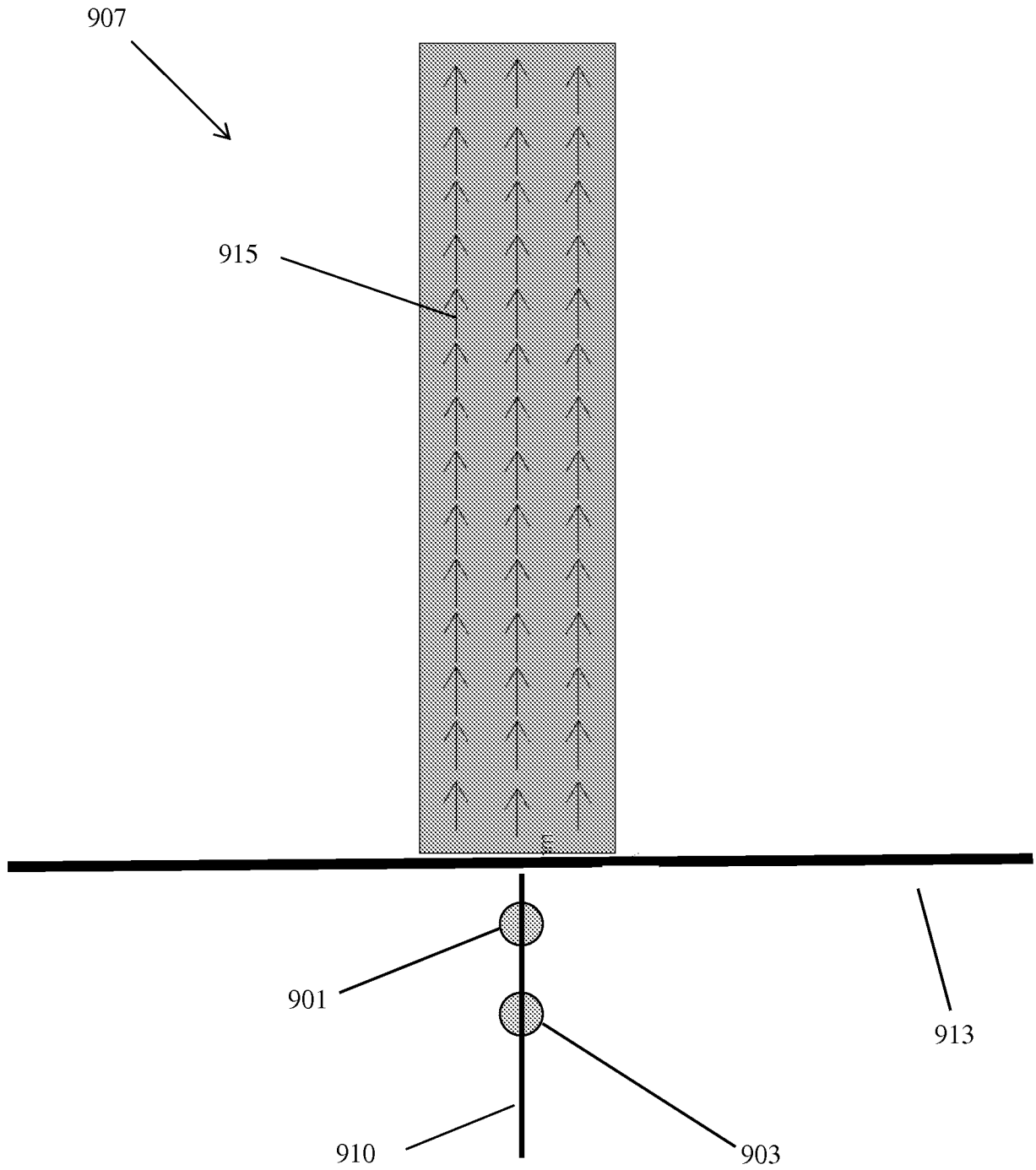

FIG. 9

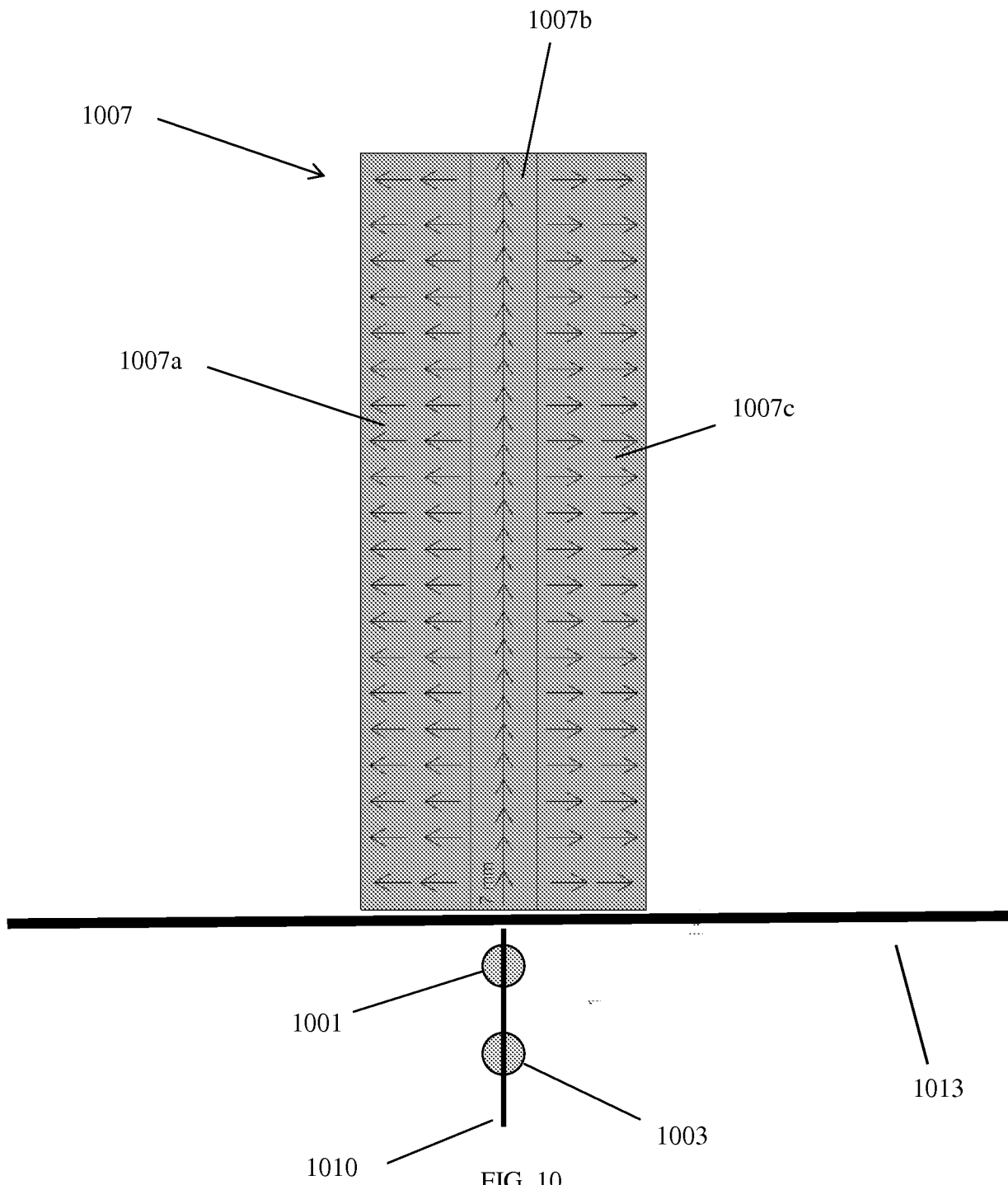

FIG. 10

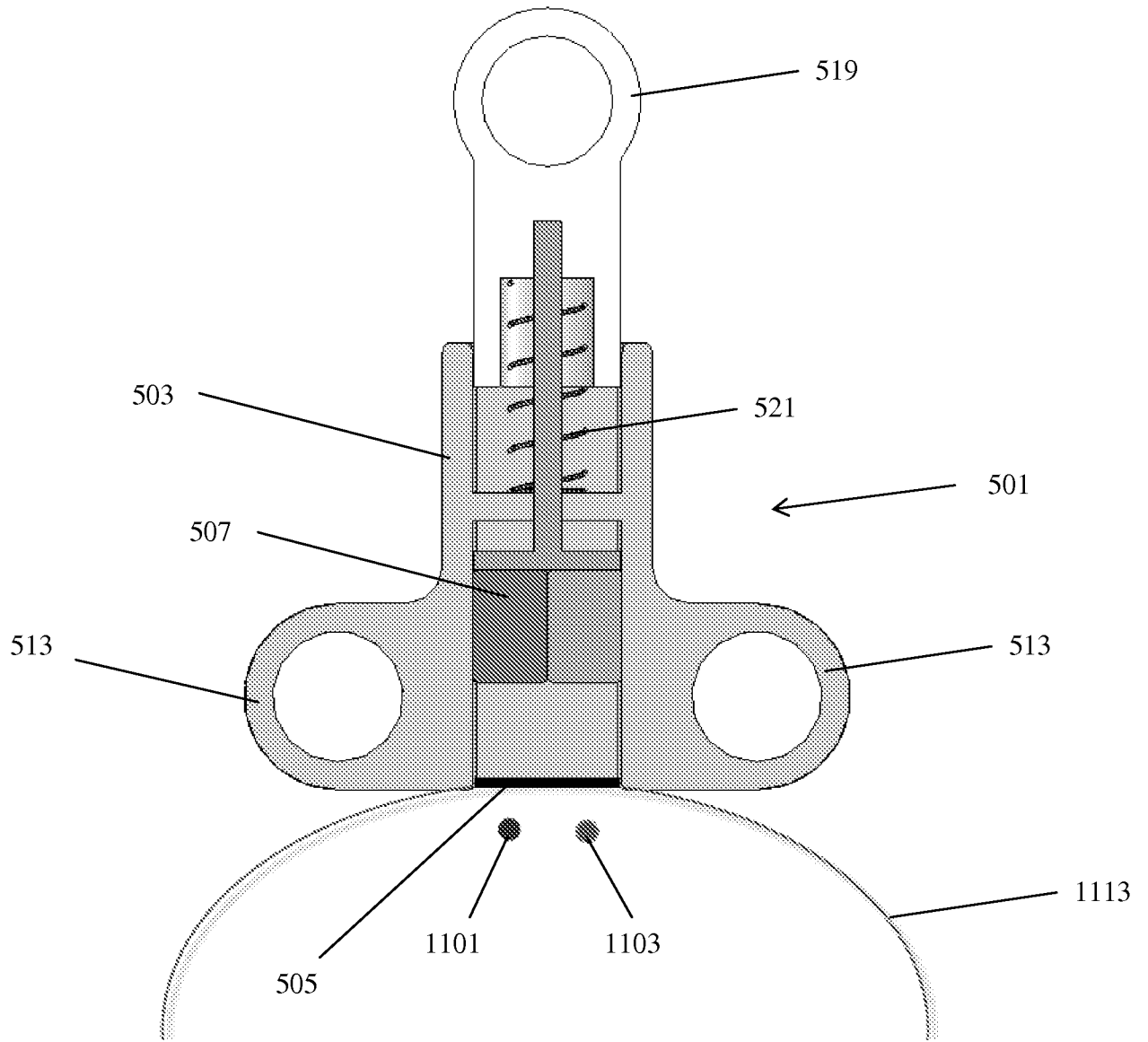

FIG. 11A

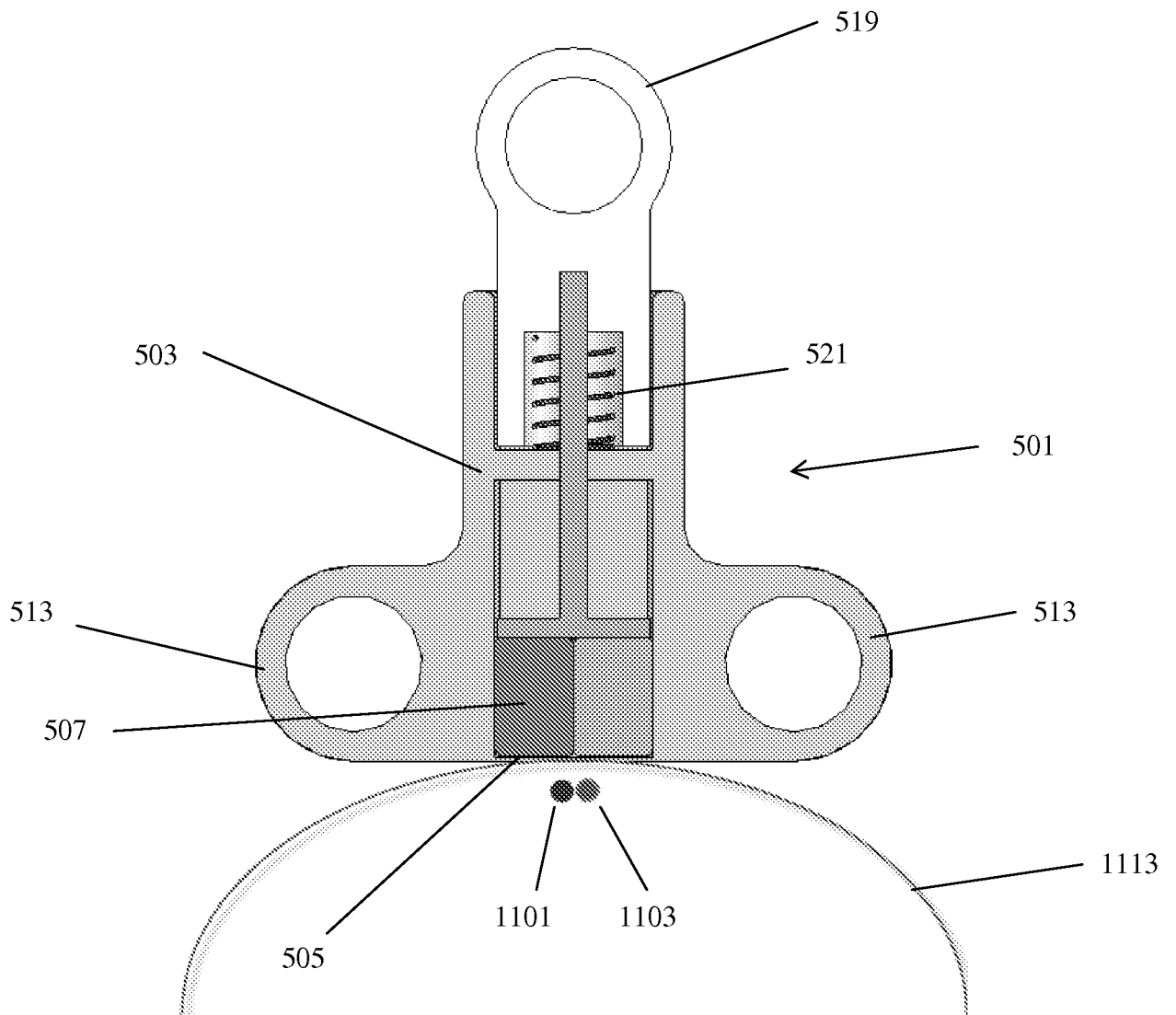

FIG. 11B

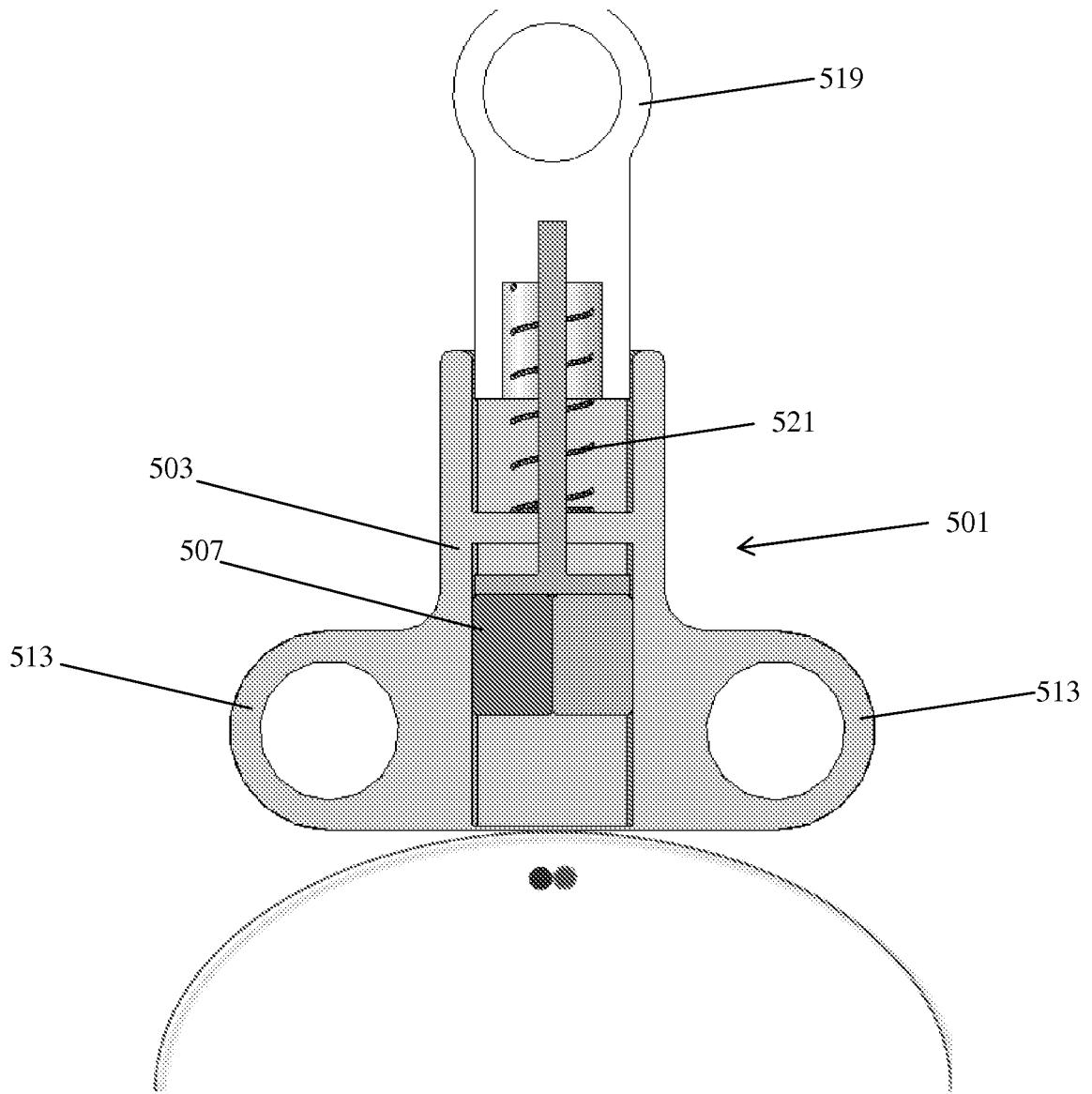

FIG. 11C

INTERNATIONAL SEARCH REPORT

International application No.

PCT/US14/29731

A. CLASSIFICATION OF SUBJECT MATTER
IPC(8) - A61M 25/088; A61N 2/06, 2/10 (2014.01)
USPC - 600/104; 604/22; 606/167, 185
 According to International Patent Classification (IPC) or to both national classification and IPC

B. FIELDS SEARCHED
 Minimum documentation searched (classification system followed by classification symbols)
IPC(8) - A61B 17/10, 17/11, 17/22, 17/32, 17/52, 18/14, 18/18, 18/24; A61M 25/00, 25/088; A61N 2/06, 2/10 (2014.01)
USPC - 600/104; 604/22; 606/167, 185

Documentation searched other than minimum documentation to the extent that such documents are included in the fields searched.

Electronic data base consulted during the international search (name of data base and, where practicable, search terms used)
 MicroPatent (US-G, US-A, EP-A, EP-B, WO, JP-bib, DE-C,B, DE-A, DE-T, DE-U, GB-A, FR-A); Google; Google Scholar; Google Patent; ProQuest; PubMed/Medline; Search Terms Used; catheter, housing, magnet, "magnetic array", external, adjustable, moveable, "magnetic field" patient

C. DOCUMENTS CONSIDERED TO BE RELEVANT

Category*	Citation of document, with indication, where appropriate, of the relevant passages	Relevant to claim No.
X	US 7341063 B2 (GARIBALDI, JM et al.) March 11, 2008; abstract; figures 9-11; column 6, lines 8-13, 20-21, 27-35, 30-33, 47-51	10
--		-----
Y		11-14
Y	US 2012/0302935 A1 (MILLER GH et al.) November 29, 2012; figures 6A-6B, 31A-31B, 33A-33B; paragraphs [0008], [0037], [0071], [0078]-[0079], [0105]-[0107], [0168]	1-9, 15-18
Y	US 2012/0059398 A1 (PATE, TD et al.) March 8, 2012; figure 13; paragraph [0044]	1-9
Y	US 6971983 B1 (CANCIO, H) December 6, 2005; column 3, lines 63-67; column 4, lines 1-3	11
Y	US 6004330 A (MIDDLEMAN, LM et al.) December 21, 1999; column 27, lines 8-13	12-13
Y	US 6032677 A (BLECHMAN, AM et al.) March 7, 2000; figure 4; column 6, lines 49-64	14
Y	US 2006/0079897 A1 (HARRISON, MR et al.) April 13, 2006; figures 30-31; paragraphs [0199]-[0201]	15-18
Y	US 7288075 B2 (PARIHAR, SK et al.) October 30, 2007; figure 3C; paragraph [0113]	6
Y	US 2009/0076324 A1 (TAKAYAMA, Y et al.) March 19, 2009; figure 2; paragraph [0075]	7
Y	US 2012/0281330 A1 (ABBOTT, JJ et al.) November 8, 2012; paragraph [0088]	8
Y	US 2011/0112427 A1 (PHILLIPS, JW et al.) May 12, 2011; figure 3; paragraph [0390]	9

Further documents are listed in the continuation of Box C.

* Special categories of cited documents:	"T" later document published after the international filing date or priority date and not in conflict with the application but cited to understand the principle or theory underlying the invention
"A" document defining the general state of the art which is not considered to be of particular relevance	"X" document of particular relevance; the claimed invention cannot be considered novel or cannot be considered to involve an inventive step when the document is taken alone
"E" earlier application or patent but published on or after the international filing date	"Y" document of particular relevance; the claimed invention cannot be considered to involve an inventive step when the document is combined with one or more other such documents, such combination being obvious to a person skilled in the art
"L" document which may throw doubts on priority claim(s) or which is cited to establish the publication date of another citation or other special reason (as specified)	"&" document member of the same patent family
"O" document referring to an oral disclosure, use, exhibition or other means	
"P" document published prior to the international filing date but later than the priority date claimed	

Date of the actual completion of the international search 29 July 2014 (29.07.2014)	Date of mailing of the international search report 22 AUG 2014
--	--

Name and mailing address of the ISA/US Mail Stop PCT, Attn: ISA/US, Commissioner for Patents P.O. Box 1450, Alexandria, Virginia 22313-1450 Facsimile No. 571-273-3201	Authorized officer: Shane Thomas PCT Helpdesk: 571-272-4300 PCT OSP: 571-272-7774
---	--

INTERNATIONAL SEARCH REPORT

International application No.

PCT/US14/29731

C (Continuation). DOCUMENTS CONSIDERED TO BE RELEVANT		
Category*	Citation of document, with indication, where appropriate, of the relevant passages	Relevant to claim No.
A	US 6099542 A (COHN WE et al.) August 8, 2000; figure 16; column 24, lines 29-32, 38-46	19-24
A	US 2008/0065019 A1 (HEUSER, RR et al.) March 13, 2008; figures 2-3, 9; paragraphs [0029], [0033], [0035]	19-24