

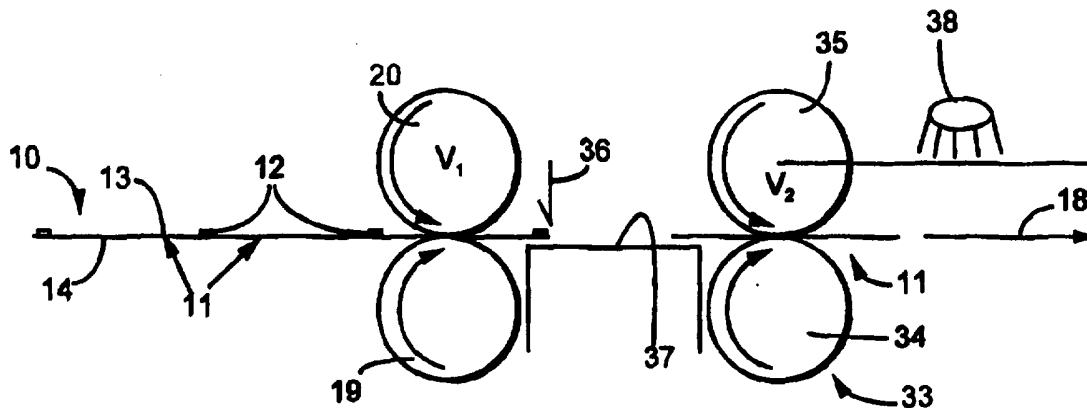

INTERNATIONAL APPLICATION PUBLISHED UNDER THE PATENT COOPERATION TREATY (PCT)

<p>(51) International Patent Classification⁶ : B65H 35/10, B26D 7/08, B26F 3/02, B65C 9/18</p>	<p>A1</p>	<p>(11) International Publication Number: WO 96/16889</p> <p>(43) International Publication Date: 6 June 1996 (06.06.96)</p>
<p>(21) International Application Number: PCT/US95/14228</p> <p>(22) International Filing Date: 3 November 1995 (03.11.95)</p> <p>(30) Priority Data: 351,221 30 November 1994 (30.11.94) US</p> <p>(71) Applicant: MOORE BUSINESS FORMS, INC. [US/US]; 300 Lang Boulevard, Grand Island, NY 14072-1697 (US).</p> <p>(72) Inventor: BOREALI, Jeff, J.; 94 Brundage Avenue, North Tonawanda, NY 14120 (US).</p> <p>(74) Agent: VANDERHYE, Robert, A.; Nixon & Vanderhye, 8th floor, 1100 North Glebe Road, Arlington, VA 22201-4714 (US).</p>		<p>(81) Designated States: AL, AM, AT, AU, BB, BG, BR, BY, CA, CH, CN, CZ, DE, DK, EE, ES, FI, GB, GE, HU, IS, JP, KE, KG, KP, KR, KZ, LK, LR, LS, LT, LU, LV, MD, MG, MK, MN, MW, MX, NO, NZ, PL, PT, RO, RU, SD, SE, SG, SI, SK, TJ, TM, TT, UA, UG, UZ, VN, European patent (AT, BE, CH, DE, DK, ES, FR, GB, GR, IE, IT, LU, MC, NL, PT, SE), OAPI patent (BF, BJ, CF, CG, CI, CM, GA, GN, ML, MR, NE, SN, TD, TG), ARIPO patent (KE, LS, MW, SD, SZ, UG).</p> <p>Published <i>With international search report. Before the expiration of the time limit for amending the claims and to be republished in the event of the receipt of amendments.</i></p>

(54) Title: NON-QUADRATE LINERLESS LABEL CONSTRUCTION, METHODS OF USE AND APPLICATION, AND APPARATUS



(57) Abstract

A label assembly (10) indicates a string of plurality of non-quadrate (e.g., circular) linerless labels (11) disposed in-line with at least one tie (12) about .018-.030 inches in width connecting consecutive labels (119) in the string together. Each label (11) has a first face (13) with adhesive release material and a second face (14) with pressure sensitive adhesive. The string may be in roll form and taken off the roll (15) and run through a burster (33) for bursting the ties (12) between the labels (11). The labels (11) may initially also be tied to a matrix (17) from which the string labels are continuously separated. The burster (33) may include high and low speed rolls (34, 35; 19, 20) with a non-stick surface (37) between them and a bursting blade (36) above the non-stick surface. Downstream of the high speed rolls is a sensor (38) and a mechanism for applying the separated linerless labels (11) to a surface, such as a reciprocating plunger (42), air blast nozzles (56, 57), a vacuum cylinder (55), or a conveyor belt (50, 53).

FOR THE PURPOSES OF INFORMATION ONLY

Codes used to identify States party to the PCT on the front pages of pamphlets publishing international applications under the PCT.

AT	Austria	GB	United Kingdom	MR	Mauritania
AU	Australia	GE	Georgia	MW	Malawi
BB	Barbados	GN	Guinea	NE	Niger
BE	Belgium	GR	Greece	NL	Netherlands
BF	Burkina Faso	HU	Hungary	NO	Norway
BG	Bulgaria	IE	Ireland	NZ	New Zealand
BJ	Benin	IT	Italy	PL	Poland
BR	Brazil	JP	Japan	PT	Portugal
BY	Belarus	KE	Kenya	RO	Romania
CA	Canada	KG	Kyrgyzstan	RU	Russian Federation
CF	Central African Republic	KP	Democratic People's Republic of Korea	SD	Sudan
CG	Congo	KR	Republic of Korea	SE	Sweden
CH	Switzerland	KZ	Kazakhstan	SI	Slovenia
CI	Côte d'Ivoire	LI	Liechtenstein	SK	Slovakia
CM	Cameroon	LK	Sri Lanka	SN	Senegal
CN	China	LU	Luxembourg	TD	Chad
CS	Czechoslovakia	LV	Latvia	TG	Togo
CZ	Czech Republic	MC	Monaco	TJ	Tajikistan
DE	Germany	MD	Republic of Moldova	TT	Trinidad and Tobago
DK	Denmark	MG	Madagascar	UA	Ukraine
ES	Spain	ML	Mali	US	United States of America
FI	Finland	MN	Mongolia	UZ	Uzbekistan
FR	France			VN	Viet Nam
GA	Gabon				

**NON-QUADRATE LINERLESS LABEL CONSTRUCTION,
METHODS OF USE AND APPLICATION, AND APPARATUS**

5 **BACKGROUND AND SUMMARY OF THE INVENTION**

 There are many circumstances in which non-quadrate (e.g.,
circular, oval, triangular, or polygonal shape) labels are utilized,
being applied to surfaces. In the last few years there has been an
10 increasing demand for linerless labels because of the
environmental and other advantages associated with them. The
use of non-quadrate linerless labels, per se, is shown in pending
application Serial No. 08/173,083, filed December 27, 1993 (the
disclosure of which is hereby incorporated by reference herein).
15 According to the present invention, a particular string of non-
quadrate linerless labels is provided, as well as a method of
detaching the individual labels from the string, a method of
separating the string from surrounding matrix material, a method
of applying burst labels directly to the surfaces of moving items,
20 and apparatus for practicing all of these methods.

 According to one aspect of the present invention, a method of
acting on individual non-quadrate linerless labels in a string of in-
line quadrate linerless labels connected to the other by ties is
25 provided. The method is practiced using a burster having a first

pair of low speed rolls, and a second pair of high speed rolls with a stationary blade between the roller pairs. The method comprises the following steps: (a) Moving the string of non-quadrate linerless labels, in a first direction, to the first pair of rolls. (b) Feeding the
5 labels, one at a time, in sequence from the low speed rolls to the high speed rolls so that a tie connecting two consecutive labels of the string is positioned between the pairs of rolls. (c) Acting on a leading string with the high-speed rolls to cause the string to be tensioned and the tie between the roll pairs to engage the
10 stationary blade and burst. And, (d) discharging the leading label, burst from the string in step (c), from the high speed rolls.

The labels have a first face with adhesive release material and a second face with pressure sensitive adhesive. Step (c) is
15 typically practiced by bringing the non-adhesive face into contact with the stationary blade. There is also preferably the further step of, except during tensioning as recited in step (c), guiding the labels from the first and second roll pairs by bringing the adhesive face into contact with a non-stick guiding surface.

20

Normally, the string of labels is originally connected to a surrounding matrix by ties, in which case there is the further step, prior to step (a), of (e) separating the leading labels from the matrix; and (f) continuously automatically pulling the matrix in a

second direction, distinct from the first direction, while physically engaging the label string so that the labels are not pulled with the matrix but instead are fed to the first rollers as recited in steps (a) and (b) separated from the matrix. Step (f) is typically practiced by
5 physically engaging the first face of the label string with a smooth, substantially stationary surface.

After the practice of step (d), there is a further step of bringing the detached leading linerless label second face into
10 contact with a surface to which the adhesive adheres. This additional step may be practiced by pushing the first face in a third direction, substantially transverse to the first direction, until the second face engages the surface, or by engaging the first face with a rotatable element and rotating the rotatable element to assist in
15 moving the label second face into contact with the surface, by substantially simultaneously moving the surface into engagement with the second face by using air blast nozzles, or the like.

There may also be the further step of sensing the presence of
20 the leading label being discharged during the practice of step (d), and moving the surface toward the label in response to that sensing. The label string is typically pulled by the low speed roll to move into proper position. Also, typically, there is a speed

differential of between 3:1 to 2:1 between the high speed and low speed rolls.

The invention also relates to a label assembly per se which
5 consists of: A string of a plurality of non-quadrate linerless labels disposed in line with at least one tie about .018-.030 inches in width connecting consecutive labels in the string together, each label having a first face with adhesive release material and a second face with pressure sensitive adhesive. The labels may be circular, with
10 a single tie connecting each label to another consecutive label in a string, and the string labels may be in roll form.

The invention also relates to apparatus for bursting individual labels from a string of in-line labels connected by ties.
15 The apparatus comprises the following elements: A pair of low speed rolls with a nip therebetween. A pair of high speed rolls, with a nip therebetween. The rolls mounted so that the nips are in an imaginary straight line, and the rolls are all rotatable about substantially parallel axes of rotation. A non-stick surface mounted
20 between the low and high speed rolls extending substantially along the imaginary straight line. And a stationary bursting blade mounted between the pairs of rolls above the non-stick surface. The non-stick surface is preferably a plasma coated surface.

Sensors are also typically associated with the apparatus, including a sensor located downstream of the high speed rolls.

The invention also relates to apparatus for separating a
5 string of in-line labels connected by ties from a surrounding matrix
to which the labels are also connected by ties. The apparatus
comprises the following elements: A conveyor mechanism for
pulling the labels in a first direction. A stationary hold-down
device for engaging the labels after separation from the matrix and
10 holding the labels so that they do not travel with the matrix. A
matrix take-up mechanism for moving the matrix in a second
direction distinct from and intersecting the first direction. And, an
abutment engaging the matrix and the string of labels where the
first and second directions intersect. The abutment preferably
15 comprises a first roller rotatable about an axis substantially
perpendicular to the first direction, which may be driven but
preferably is an idler roller. The matrix take-up preferably
includes a powered second roller rotatable about an axis parallel to
the first roller axis. The stationary hold-down device preferably
20 comprises an arm of rigid, smooth material.

According to another aspect of the present invention,
linerless label applying apparatus is provided. This apparatus
comprises the following elements: A pair of rolls having a nip

therebetween, the rolls rotatable about parallel axes, extending in a first dimension, and the rolls pulling a linerless label therebetween in a second direction substantially perpendicular to the first dimension. Label engaging means downstream of the rolls in the second direction for engaging a label as it moves through the nip. And, conveyor means for moving a surface into operative association with the label engaging means so that the label is applied to the surface. The label engaging means may comprise a reciprocating plunger, conveyor belt, vacuum cylinder, at least one gas blast nozzle, or a variety of other structures.

It is a primary object of the present invention to provide for the effective and simple detachment of non-quadrate linerless labels from a string, and the application of the detached labels to a moving surface, in an automatic manner. This and other objects of the invention will become clear from an inspection of the detailed description of the invention and from the appended claims.

BRIEF DESCRIPTION OF THE DRAWINGS

20

FIGURE 1 is a side view of a label assembly string according to the present invention moving from roll to linear form;

FIGURE 2 is a top plan view of the string in FIGURE 1;

FIGURE 3 is a top plan view of a string like that of FIGURE 2 before detachment from the surrounding matrix material;

FIGURE 4 is a side schematic view of apparatus for
5 separating the label string of FIGURE 3 from the matrix material of FIGURE 3;

FIGURE 5 is a top perspective schematic view of the apparatus of FIGURE 4;
10

FIGURE 6 is a side schematic view of an exemplary bursting apparatus for bursting the label string of FIGURE 2, according to the present invention;

15 FIGURES 7 and 8 are side schematic views showing the high speed rolls of the burster of FIGURE 6 in conjunction with a reciprocating plunger for applying a detached label to a moving surface;

20 FIGURES 9 and 10 are views like those of FIGURES 7 and 8 only showing a belt conveyor system downstream of the high speed roll for applying the label to a bottle or the like;

FIGURES 11 and 12 are views like that of FIGURES 7 and 8 only showing a vacuum cylinder and differently disposed conveyor downstream of the high speed roll; and

5 FIGURE 13 is a view like that of FIGURE 12 only showing gas blast nozzles for operatively engaging a detached label and moving it into contact with a surface being conveyed.

DETAILED DESCRIPTION OF THE DRAWINGS

10

A label assembly according to the present invention is shown generally by reference numeral 10 in FIGURES 1 and 2. It consists of a string of a plurality of non-quadrate linerless labels 11 disposed in-line with at least one tie about .018-.030 inches in
15 width connecting consecutive labels and the string together. Each label 11 has a first face 13 with adhesive release material, e.g., silicone, thereon and a second face 14 (see FIG. 1) with pressure-sensitive adhesive (which may be repositional, removable or permanent). The assembly 10 may be in roll form, as illustrated by
20 the roll 15 in FIGURE 1, and taken off from the roll intermittently, continuously, or in groups (such as the group illustrated in FIG. 2).

The non-quadrate configuration of the labels 11 may be of a wide variety of different types. For example, the labels 11 may be

circular as seen in FIGURES 1 and 2, oval, triangular, or of another non-quadrate polygon shape. Where circular labels 11 are utilized, as seen in FIGURES 1 and 2, typically only a single tie 12 is provided between adjacent labels. Where the labels have other
5 shapes, more than one tie may be provided, but the ties typically always have a width of between about .018-.030 inches.

Normally -- as described in said copending application Serial No. 08/173,083 -- the string of labels is initially within a matrix 17 -
10 - as seen in FIGURE 3. It is also connected to the matrix by ties -- such as the ties 18, which also preferably have a width of about .018-.030 inches. The string of labels 10 is separated from the matrix material 17 automatically, preferably utilizing the apparatus such as illustrated in FIGURES 4 and 5.

15

The apparatus of FIGURES 4 and 5 includes a conveying mechanism for conveying the string of labels in a first direction 18 (see FIG. 4), the conveyor mechanism typically comprising the low speed rolls 19, 20 of a detacher (as illustrated in FIG. 6). A
20 conveyor belt, conveyor bottom rollers, conveying slats, conveying chains, toothed wheels, or a wide variety of other mechanisms may also be provided as the conveying means for moving the label string in the direction 18.

The matrix/label string detachment mechanism also preferably comprises a stationary label hold-down mechanism 21, which may --as illustrated in FIGS. 4 and 5 -- be in the form of an arm having an angled body portion 22 stationarily mounted to a stationary support 23 at a first end thereof, a bottom portion 24 which is substantially parallel to the direction 18, and an up-
5 turned end portion 25 of the element 24. The arm 21 is preferably formed of a piece of Lexan or plastic, and is relatively rigid, although it has some flexibility. It is typically light in weight and preferably at least the portion thereof that engage the adhesive
10 release faces 13 or the label string 10 is smooth so that it does not mark, tear or otherwise adversely affect the labels 11.

The matrix/label detachment mechanism also includes a matrix take-up shown generally by reference numeral 26, and
15 preferably including a take-up roller 27 driven by a motor 28 or the like and about which the matrix material 17 is initially wrapped. The axis of rotation of the roller 27, about which it is driven by the motor 28, is in a second dimension 29 which is preferably
20 perpendicular to the first direction 18. The take-up roller 27 moves the matrix in a second direction 30, which is distinct from and intersects the first direction 18. In the preferred embodiment illustrated in FIGURES 4 and 5, the second direction 30 is perpendicular to the first direction 18.

Finally, the matrix/label string separation mechanism comprises an abutment, preferably a powered or idler roller 31, engaging the matrix 17 and the string of labels 10 where the first and second directions 18/30 intersect. The roller 31 is rotatable
5 about an axis parallel to the axis 29. When powered the roller 31 may comprise, or may comprise part of, the conveyor mechanism for pulling the labels in the direction 18.

An exemplary burster according to the present invention is
10 shown generally by reference numeral 33. In addition to the low speed rolls 19, 20 the burster 33 includes a pair of high speed rolls 34, 35, each of the sets of rolls 19, 20 and 34, 35 having a nip between them. The rolls 19, 20 and 34, 35 are mounted so that the nips are in an imaginary straight line from one to the other
15 (preferably at the same horizontal or vertical position) and all of the rolls 19, 20, 34, 35 are rotatable about substantially parallel axes of rotation. The burster 33 also includes a bursting blade 36 disposed between the rollers on one side of the imaginary straight line between the roller nips, and adapted to engage the release
20 material surface 13 of the leading label 11 in a string 10 at the tie 12 so that bursting along the tie 12 takes place.

The stationary bursting blade 36 is also over a non-stick guide surface 37 which is also mounted between the rolls 19, 20

and 34, 35 and extend substantially along the imaginary straight line between the nips. The non-stick surface 37 engages the pressure-sensitive adhesive 14 face of the label string 10. It is preferred that the non-stick characteristics of the surface 37 be
5 obtained by plasma coating, such as is shown per se in copending application Serial No. _____, filed _____ (atty. dkt. 263-_____), the disclosure of which is hereby incorporated by reference herein. The lower low speed roller 19 and the lower high speed roller 34, which engage the adhesive surface 14, also are both
10 preferably non-stick coated, so that they do not adhere to the adhesive 14. Also the distance between the roll pairs 19, 20 and 34, 35 are fixed to one label 11 length, with the tie 12 (or a series of ties) aligned with the bursting blade 36.

15 Conventional bursters (which are similar to the burster 33 only not utilizing the non-stick surface 37 and corresponding non-stick surfaces on the rollers 19, 34) typically operate at a differential speed ratio of 2:1 between the high speed and low speed rolls. The speed ratio according to the present invention is
20 preferably between 3:1 and 2:1, including all ratios inbetween. Also, a sensor 38 (of any suitable conventional type, e.g., optical) is preferably provided downstream of the high speed rolls 34, 35 in the direction 18 to sense a leading label 11 after it has been burst, and to in turn move a surface into contact with the label and/or

operate another label engaging element to engage the label and move it into contact with the surface. A second sensor (shown generally at 39 in FIG. 9) may also be provided to sense a moving surface to which the detached label 11 is to be applied. The sensors
5 38, 39 may also control the drive of the high speed rolls 34, 35 to stop the drive so that the leading label is essentially parked until acted upon by a label engaging element or a moving surface to which the label is applied.

10 A wide variety of label-engaging means may be provided downstream of the high speed rolls 34, 35 in the first direction 18 for engaging a label 11 as it moves through the nip of the high speed rolls 34, 35. Four different such label engaging means are illustrated in FIGURES 7 through 13. All of them may be
15 integrated with the operation of the rollers 34, 35 by the sensor 38 and/or the sensor 39.

In the FIGURES 7 and 8 embodiment, the label-engaging means comprises a horizontally movable plunger 42 mounted for
20 movement by a rod 43 in a direction 44 perpendicular to the direction 18. The plunger 42 engages the release material face 13 of the label 11 and moves the adhesive face 14 into contact with a surface 45 to which the labels can be applied. In FIGURE 8 the surface 45 is shown as being one of the sides or top of a cardboard

carton 66, which is mounted on a conveyor means 47 for movement in the direction 48. In the exemplary embodiment illustrated in FIGURES 7 and 8, the direction 48 is parallel to the direction 18, but that is not necessary. The conveying means 47 may be any
5 conventional conveyor such as a conveyor belt, conveyor rollers, conveyor chains, conveyor platforms, etc.

In the embodiment of FIGURES 9 and 10 the label engaging means comprises a conveyor belt 50 mounted just downstream of
10 the nip of the rolls 34, 35 in the direction 18 in position to cooperate with a bottle, can or like element 51 having a surface to which the label 11 is applied. The bottle 51 is moved by the conveyor 47 in the direction 52, the direction 52 in this case being perpendicular to the direction 18. A second conveyor belt assembly 53 is mounted on
15 the opposite side of the conveyor 47 from the conveyor belt assembly 50 to rotate the bottle 51 as it moves in direction 52 and as the label 11 is being applied, as illustrated in FIGURE 10. Conveyor belt assemblies 50, 53 can be driven or not driven, although it is preferred that the assembly 53 at least be driven.

20

FIGURE 11 illustrates yet another form of label engaging means in this case in the form of a vacuum cylinder 55 which is mounted just downstream of the nip between the roller 34, 35 and is rotatable about an axis parallel to the rollers 35, 34 axes. The

vacuum cylinder 55 engages the non-adhesive face 13 of the label 11 and moves the adhesive face 14 into contact with a surface 45 of a carton 46, or like object, being conveyed by the conveyor 47 in the direction 52, as seen in FIGURE 12.

5

FIGURE 13 illustrates another embodiment of the label engaging means in which just downstream of the nip between the rolls 34, 35 one more air/gas blast nozzles 56, 57 are located. The nozzles 56, 57 are connected up to a source of compressed gas (e.g., air, nitrogen, etc.) 58. Valves for automatically controlling the passage of compressed gas from the source 58 to the nozzles 56, 57 may be controlled by a sensor like sensor 38 in FIGURE 6 (e.g., an optical sensor). The blasts of gas from the nozzles 56, 57 conveys the label 11 to the surface 45 of a carton 45 or like device being moved in direction 59 by the conveyor 47 (in this case the conveyor 47 being schematically illustrated as powered rollers with gripping surfaces). In this case the direction 59 may make an angle of about 30-60° with respect to the direction 18.

20

The embodiments of FIGURES 7 through 13 illustrate various mechanisms for trapping, blowing or rolling a label detached by the detacher 33, onto a surface onto which the label is to be applied. However, other types of mechanisms also may be utilized for performing the same basic function.

It will thus be seen that according to the present invention, an advantageous label assembly consisting of a string of a plurality of non-quadrate linerless labels with ties between them, a method of acting upon individual non-quadrate linerless labels to separate
5 them from the string and apply them to product surfaces, and a variety of different apparatus may be utilized which are highly advantageous.

While the invention has been herein shown and described in
10 what is presently conceived to be the most practical and preferred embodiment, it will be apparent to those of ordinary skill in the art that many modifications may be made thereof within the scope of the invention, which scope is to be accorded the broadest interpretation of claims so as to encompass all equivalent methods,
15 products and apparatus.

WHAT IS CLAIMED IS:

1. A method of acting on an individual non-quadrate linerless label in a string of in-line non-quadrate linerless labels connected together by ties, using a burster having a first pair of low speed rolls, and a second pair of high speed rolls, with a stationary blade between the roller pairs, comprising the steps of:

(a) moving the string of non-quadrate linerless labels, in a first direction, to the first pair of rolls;

(b) feeding the labels, one at a time, in sequence from the low speed rolls to the high speed rolls so that a tie connecting two consecutive labels of the string is positioned between the pairs of rolls;

(c) acting on a leading string with the high speed rolls to cause the string to be tensioned and the tie between the roll pairs to engage the stationary blade and burst; and

(d) discharging the leading label, burst from the string in step (c), from the high speed rolls.

2. A method as recited in claim 1 wherein the labels having a first face with adhesive release material and a second face with pressure sensitive adhesive; and wherein step (c) is practiced by bringing the non-adhesive face into contact with the stationary blade.

3. A method as recited in claim 2 comprising the further step of, except during tensioning as recited in step (c), guiding the labels from the first to the second roll pairs by bringing the adhesive face into contact with a non-stick guiding surface.

4. A method as recited in claim 1 wherein the string of labels is

connected to a surrounding matrix by ties, and comprising the further steps, prior to step (a), of (e) separating the leading labels from the matrix; and (f) continuously automatically pulling the matrix in a second direction, distinct from the first direction, while physically engaging the label string so that the labels are not pulled with the matrix but instead are fed to the first rollers as recited in steps (a) and (b) separated from the matrix.

5. A method as recited in claim 4 wherein the labels have a first face with adhesive release material and a second face with pressure sensitive adhesive; and wherein step (f) is practiced by physically engaging the first face of the label string with a smooth, substantially stationary, surface.

6. A method as recited in claim 2 comprising the further step (e), substantially immediately after step (d), of bringing the detached, leading linerless label second face into contact with a surface to which the adhesive adheres.

7. A method as recited in claim 6 wherein step (e) is practiced by pushing the first face in a third direction, substantially transverse to the first direction, until the second face engages the surface.

8. A method as recited in claim 6 wherein step (e) is practiced by engaging the first face with a rotatable element, and rotating the rotatable element to assist in moving the label second face into contact with the surface.

9. A method as recited in claim 8 wherein step (e) is further practiced by substantially simultaneously moving the surface into engagement with the second face.

10. A method as recited in claim 6 comprising the further step (f) of sensing the presence of the leading label being discharged during the practice of step (d), and moving the surface toward the label in response to step (f).

11. A method as recited in claim 4 wherein steps (a) and (f) are practiced essentially solely by pulling the label string with the low speed rolls.

12. A method as recited in claim 1 wherein the labels are substantially circular, and the leading label is connected to the following label by a single tie having a width of about .018-.030 inches; and wherein step (c) is practiced by moving the single tie into contact with the stationary blade.

13. A method as recited in claim 1 wherein steps (a)-(c) are practiced by providing a speed differential of between 3:1 to 2:1 between the high speed and low speed rolls.

14. A method as recited in claim 2 wherein the labels are substantially circular, and the leading label is connected to the following label by a single tie having a width of about .018-.030 inches; and wherein step (c) is practiced by moving the single tie into contact with the stationary blade.

15. A method as recited in claim 4 wherein the labels are substantially circular, and the leading label is connected to the following label by a single tie having a width of about .018-.030 inches; and wherein step (c) is practiced by moving the single tie into contact with the stationary blade.

16. A method as recited in claim 11 wherein the labels are substantially circular, and the leading label is connected to the following label by a single tie having a width of about .018-.030 inches; and wherein step (c) is practiced by moving the single tie into contact with the stationary blade.

17. A method as recited in claim 7 wherein the labels are substantially circular, and the leading label is connected to the following label by a single tie having a width of about .018-.030 inches; and wherein step (c) is practiced by moving the single tie into contact with the stationary blade.

18. A method as recited in claim 12 wherein steps (a)-(c) are practiced by providing a speed differential of between 3:1 to 2:1 between the high speed and low speed rolls.

19. A method as recited in claim 2 wherein steps (a)-(c) are practiced by providing a speed differential of between 3:1 to 2:1 between the high speed and low speed rolls.

20. A method as recited in claim 4 wherein steps (a)-(c) are practiced by providing a speed differential of between 3:1 to 2:1 between the high speed and low speed rolls.

21. A method as recited in claim 11 wherein steps (a)-(c) are practiced by providing a speed differential of between 3:1 to 2:1 between the high speed and low speed rolls.

FIG. 1

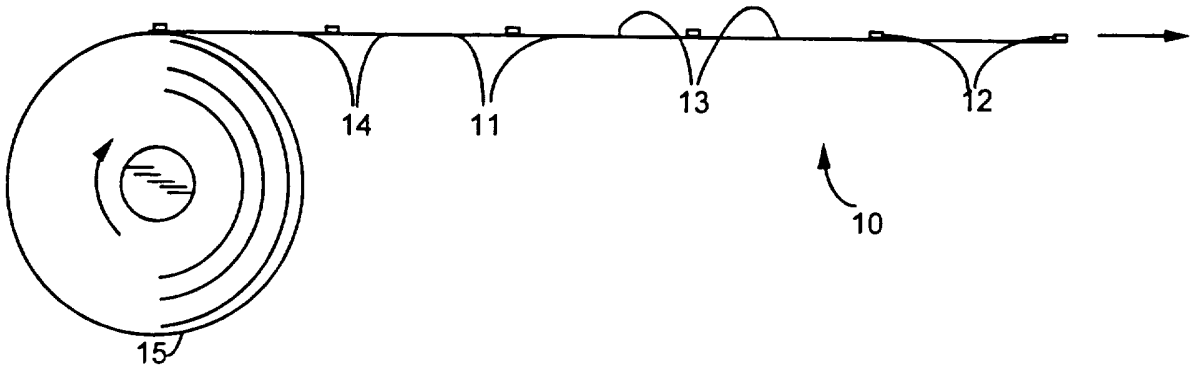

FIG. 2

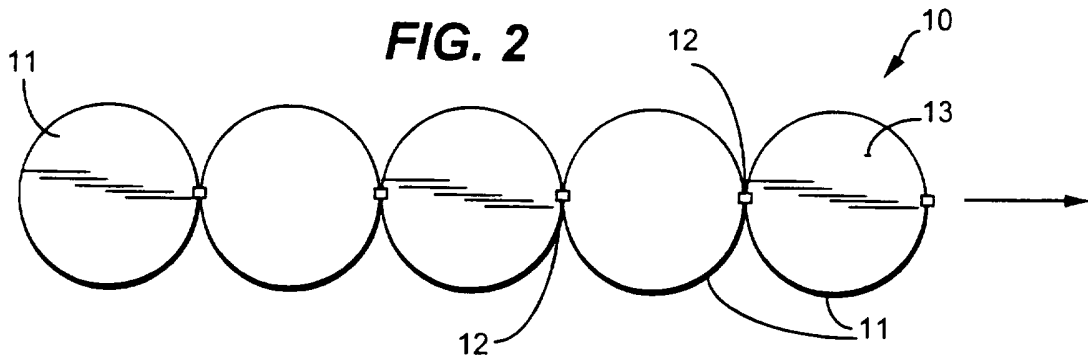

FIG. 3

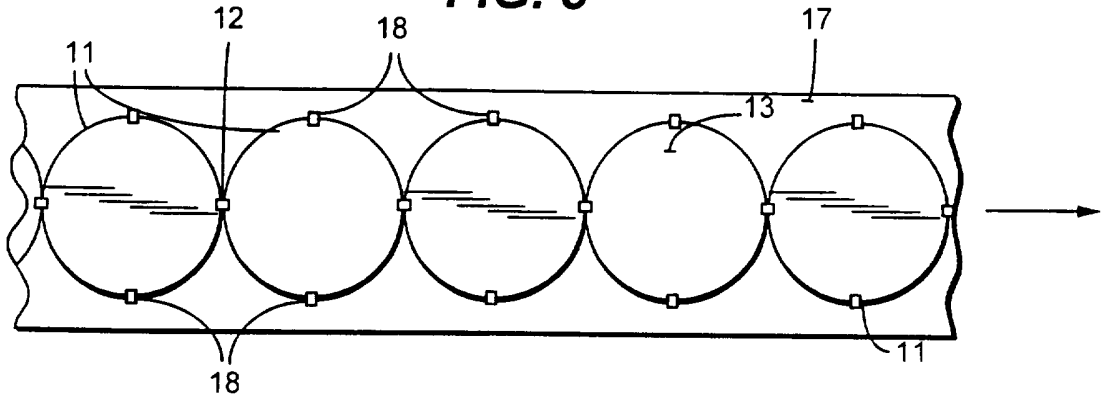
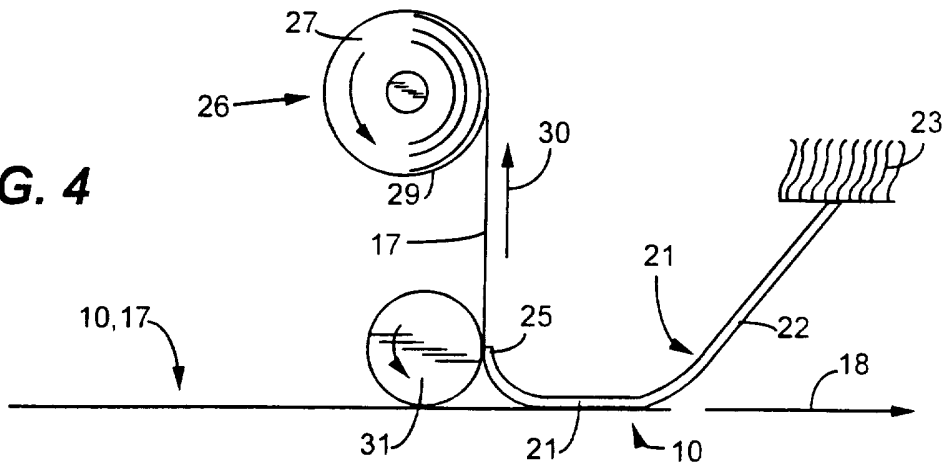
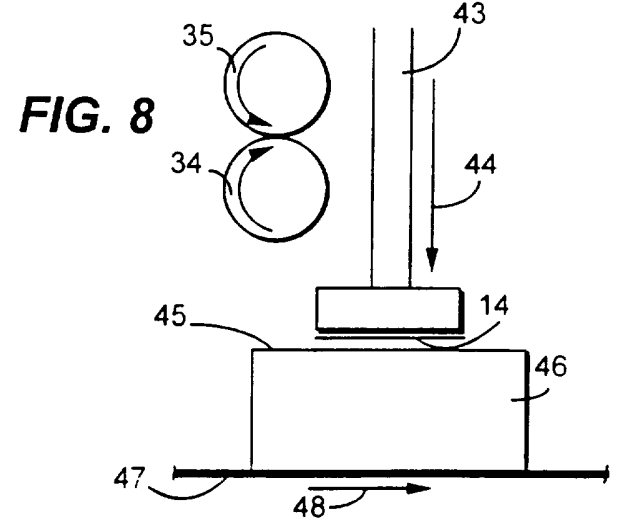
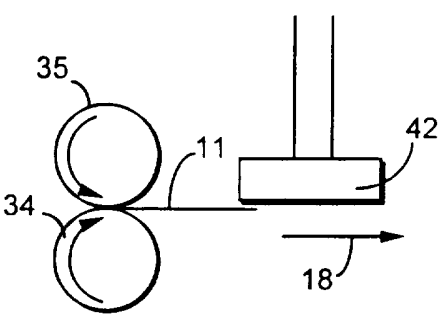
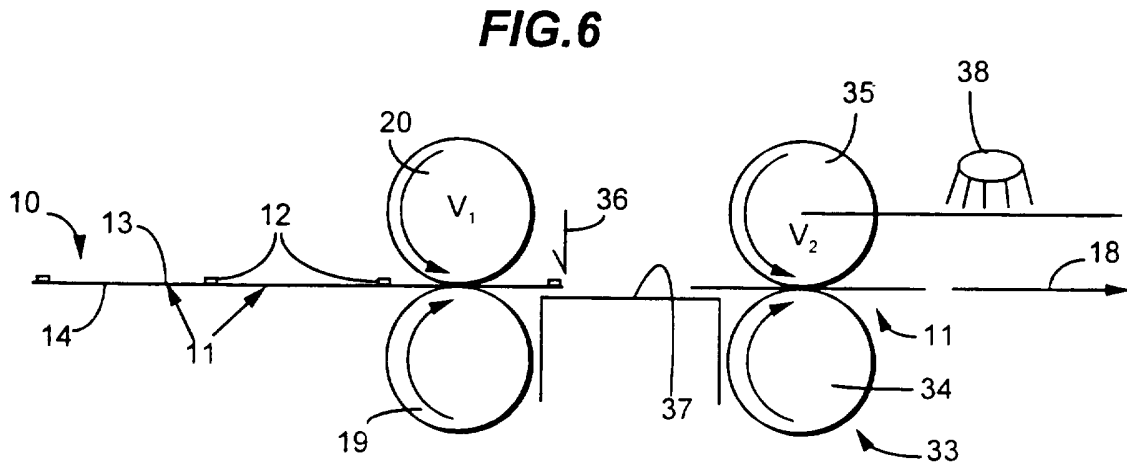
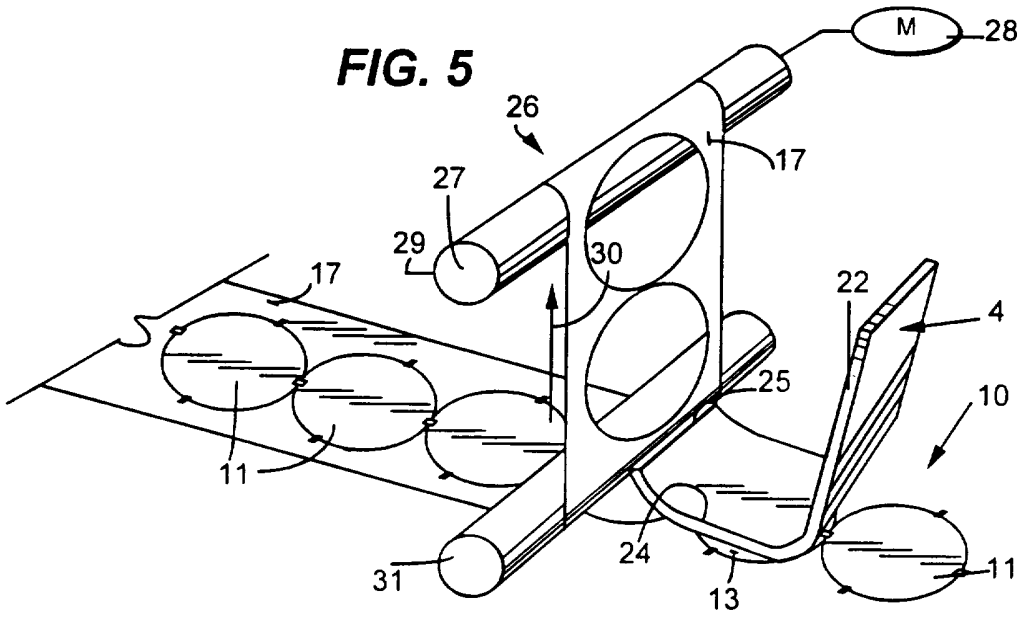

FIG. 4



SUBSTITUTE SHEET (RULE 26)



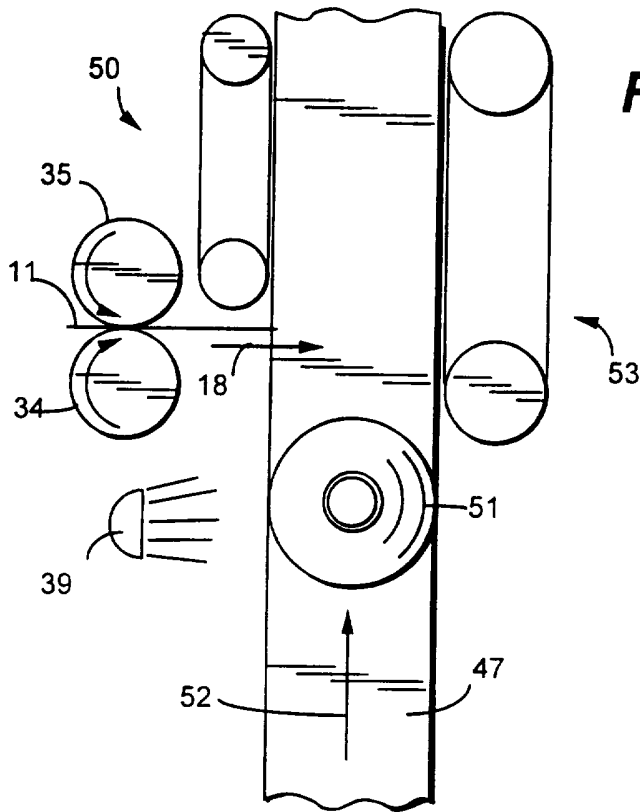

FIG. 9

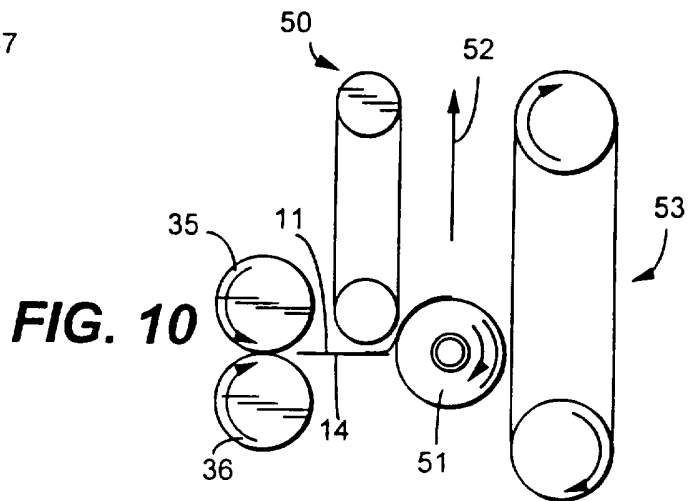

FIG. 10

FIG. 11

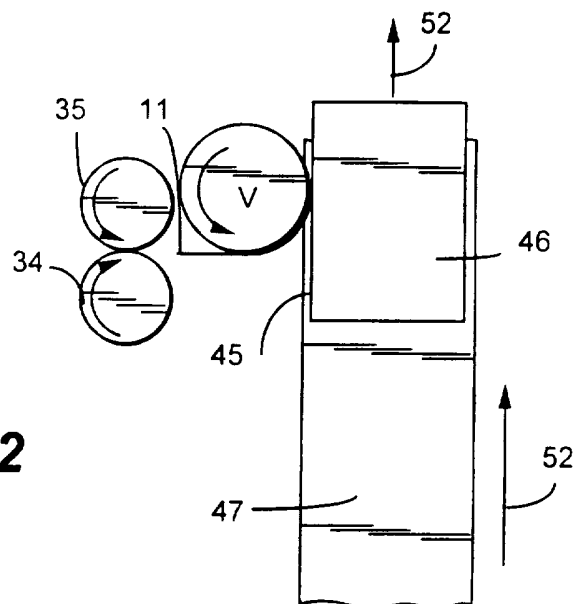
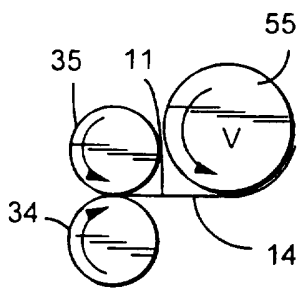
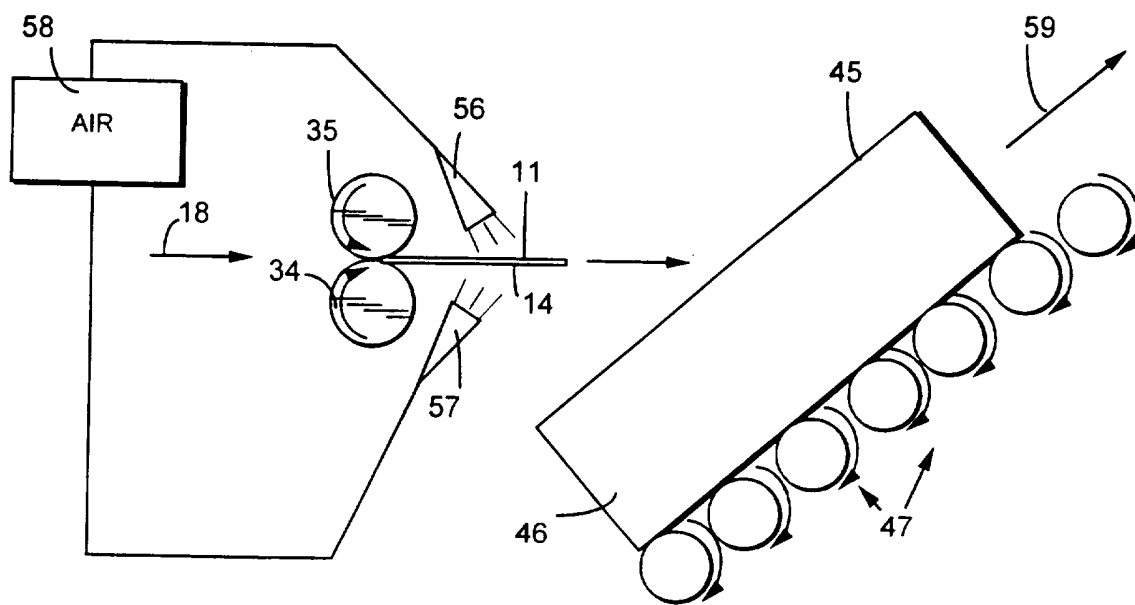

FIG. 12

FIG. 13



INTERNATIONAL SEARCH REPORT

International Application No

PCT/US 95/14228

A. CLASSIFICATION OF SUBJECT MATTER
 IPC 6 B65H35/10 B26D7/08 B26F3/02 B65C9/18

According to International Patent Classification (IPC) or to both national classification and IPC

B. FIELDS SEARCHED

Minimum documentation searched (classification system followed by classification symbols)

IPC 6 B65H B26D B26F B65C

Documentation searched other than minimum documentation to the extent that such documents are included in the fields searched

Electronic data base consulted during the international search (name of data base and, where practical, search terms used)

C. DOCUMENTS CONSIDERED TO BE RELEVANT

Category *	Citation of document, with indication, where appropriate, of the relevant passages	Relevant to claim No.
P,X	WO,A,95 15905 (MOORE BUSINESS FORMS INC.) 15 June 1995 see the whole document ---	1-3
A	EP,A,0 360 108 (R. ANCKER JORGENSEN A/S) 28 March 1990 see column 1, line 26 - column 7, line 37; figures ---	1,2,4, 6-10,12
A	EP,A,0 577 241 (MOORE BUSINESS FORMS INC.) 5 January 1994 see the whole document ---	1
A	EP,A,0 361 184 (R. ANCKER JORGENSEN A/S) 4 April 1990 see column 1, line 1 - column 3, line 26 see column 5, line 36 - column 6, line 17; figures 1,2,5-11 ---	1,12
	-/--	



Further documents are listed in the continuation of box C.



Patent family members are listed in annex.

* Special categories of cited documents:

- *A* document defining the general state of the art which is not considered to be of particular relevance
- *E* earlier document but published on or after the international filing date
- *L* document which may throw doubts on priority claim(s) or which is cited to establish the publication date of another citation or other special reason (as specified)
- *O* document referring to an oral disclosure, use, exhibition or other means
- *P* document published prior to the international filing date but later than the priority date claimed

T later document published after the international filing date or priority date and not in conflict with the application but cited to understand the principle or theory underlying the invention

X document of particular relevance; the claimed invention cannot be considered novel or cannot be considered to involve an inventive step when the document is taken alone

Y document of particular relevance; the claimed invention cannot be considered to involve an inventive step when the document is combined with one or more other such documents, such combination being obvious to a person skilled in the art.

& document member of the same patent family

Date of the actual completion of the international search

28 March 1996

Date of mailing of the international search report

15.04.96

Name and mailing address of the ISA

European Patent Office, P.B. 5818 Patentlaan 2
 NL - 2280 HV Rijswijk
 Tel. (+ 31-70) 340-2040, Tx. 31 651 epo nl,
 Fax (+ 31-70) 340-3016

Authorized officer

Raven, P

INTERNATIONAL SEARCH REPORT

Int. Patent Application No
PCT/US 95/14228

C.(Continuation) DOCUMENTS CONSIDERED TO BE RELEVANT		
Category	Citation of document, with indication, where appropriate, of the relevant passages	Relevant to claim No.
A	US,A,3 193 430 (E. E. MESSMER ET AL) 6 July 1965 see the whole document ---	1
A	EP,A,0 376 754 (TOPPAN MOORE COMPANY) 4 July 1990 see column 6, line 14 - line 30 see column 8, line 49 - column 9, line 10; figures 1,6 -----	1

INTERNATIONAL SEARCH REPORT

Information on patent family members

International Application No

PCT/US 95/14228

Patent document cited in search report	Publication date	Patent family member(s)	Publication date
WO-A-9515905	15-06-95	AU-B- 1263895	27-06-95
		BR-A- 9405824	05-12-95
		CA-A- 2153803	15-06-95
		EP-A- 0682636	22-11-95
EP-A-360108	28-03-90	DE-A- 3832239	29-03-90
		DE-A- 3927820	28-02-91
		AU-B- 615799	10-10-91
		AU-B- 4171889	29-03-90
		AU-B- 623432	14-05-92
		AU-B- 4172689	29-03-90
		EP-A- 0361184	04-04-90
		JP-A- 2115289	27-04-90
		JP-A- 2191137	27-07-90
		US-A- 4985096	15-01-91
		US-A- 5017412	21-05-91
		US-A- 5112427	12-05-92
		EP-A-577241	05-01-94
CA-A- 2096384	02-01-94		
DE-U- 9321009	24-08-95		
DE-D- 69301342	29-02-96		
EP-A- 0673839	27-09-95		
JP-A- 6080131	22-03-94		
EP-A-361184	04-04-90	DE-A- 3832239	29-03-90
		DE-A- 3927821	28-02-91
		AU-B- 615799	10-10-91
		AU-B- 4171889	29-03-90
		AU-B- 623432	14-05-92
		AU-B- 4172689	29-03-90
		EP-A,B 0360108	28-03-90
		JP-A- 2115289	27-04-90
		JP-A- 2191137	27-07-90
		US-A- 4985096	15-01-91
		US-A- 5017412	21-05-91
		US-A- 5112427	12-05-92
		EP-A- 0414056	27-02-91
US-A-3193430	06-07-65	NONE	

INTERNATIONAL SEARCH REPORT

Information on patent family members

International Application No PCT/US 95/14228

Patent document cited in search report	Publication date	Patent family member(s)	Publication date
EP-A-376754	04-07-90	JP-A- 2205496 JP-A- 2180598 JP-A- 2180599 JP-A- 2180600 AU-B- 637592 AU-B- 4738589 CA-A- 2006908 DE-D- 68925026 US-A- 5104022	15-08-90 13-07-90 13-07-90 13-07-90 03-06-93 05-07-90 29-06-90 18-01-96 14-04-92
