

(12) INTERNATIONAL APPLICATION PUBLISHED UNDER THE PATENT COOPERATION TREATY (PCT)

(19) World Intellectual Property Organization
International Bureau



(43) International Publication Date
17 October 2002 (17.10.2002)

PCT

(10) International Publication Number
WO 02/082384 A1

- (51) International Patent Classification⁷: G07D 3/02, EKLUND, Markus [SE/SE]; Simbylevägen 10 b, S-761 G07B 15/00 60 Norrtälje (SE).
- (21) International Application Number: PCT/SE02/00604 (74) Agent: ALBIHNS STOCKHOLM AB; P.O. Box 5581, S-114 85 Stockholm (SE).
- (22) International Filing Date: 26 March 2002 (26.03.2002)
- (25) Filing Language: Swedish (81) Designated States (national): AE, AG, AL, AM, AT, AU, AZ, BA, BB, BG, BR, BY, BZ, CA, CH, CN, CO, CR, CU, CZ, DE, DK, DM, DZ, EC, EE, ES, FI, GB, GD, GE, GH, GM, HR, HU, ID, IL, IN, IS, JP, KE, KG, KP, KR, KZ, LC, LK, LR, LS, LT, LU, LV, MA, MD, MG, MK, MN, MW, MX, MZ, NO, NZ, OM, PH, PL, PT, RO, RU, SD, SE, SG, SI, SK, SL, TJ, TM, TN, TR, TT, TZ, UA, UG, US, UZ, VN, YU, ZA, ZM, ZW.
- (26) Publication Language: English (84) Designated States (regional): ARIPO patent (GH, GM, KE, LS, MW, MZ, SD, SL, SZ, TZ, UG, ZM, ZW), Eurasian patent (AM, AZ, BY, KG, KZ, MD, RU, TJ, TM), European patent (AT, BE, CH, CY, DE, DK, ES, FI, FR, GB, GR, IE, IT, LU, MC, NL, PT, SE, TR), OAPI patent
- (30) Priority Data: 0101235-0 6 April 2001 (06.04.2001) SE
- (71) Applicant (for all designated States except US): CASH-GUARD AB [SE/SE]; Propellervägen 4 A, S-183 62 Täby (SE)
- (72) Inventors; and
- (75) Inventors/Applicants (for US only): HELLOQVIST, Patrik [SE/SE]; Sorterarvägen 4, S-184 70 Åkersberga (SE).

[Continued on next page]

(54) Title: A COIN SORTER APPARATUS AND USE OF A SUCH APPARATUS

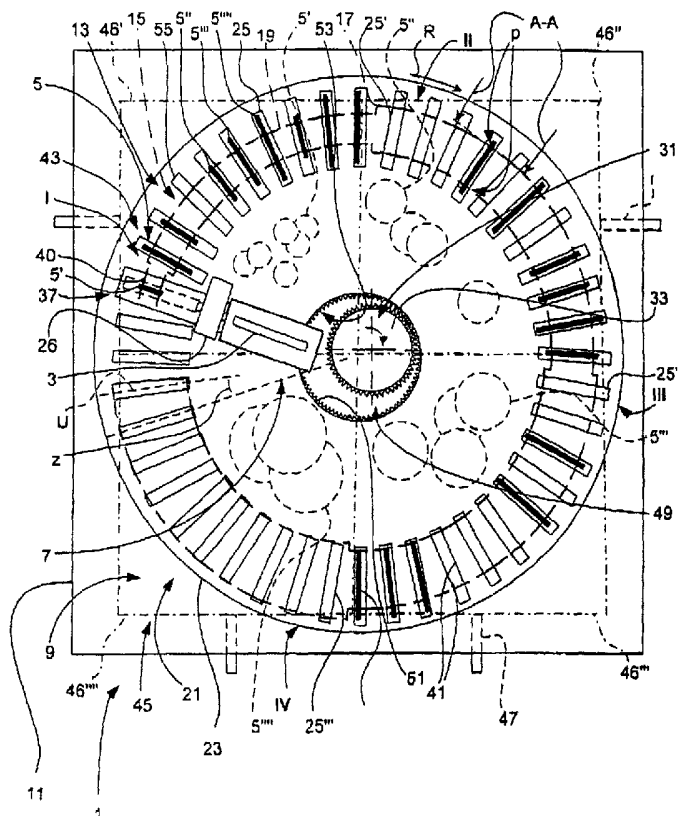

(57) Abstract: The invention relates to a coin sorter apparatus (1) comprising at least one opening (3) for coins (5) of different size, at least one distribution means (9) arranged in essentially horizontal extent and comprising an area (13) forming at least one aperture (15), which opening (3) communicates with a transport device (21) interacting with the distribution means (9). The distribution means (9) comprises a portion (37) designed for receiving coins (5) standing vertically on their edge by means of a guide means (43) arranged on the transport device (21), the aperture (15) of the distribution means (9), adapted for distribution of the coins (5) to at least one sorting unit (45), consisting of a slot (19) designed with steps (17). The invention also relates to the use of such a coin sorter apparatus.

WO 02/082384 A1



(BF, BJ, CF, CG, CI, CM, GA, GN, GQ, GW, ML, MR, NE, SN, TD, TG).

For two-letter codes and other abbreviations, refer to the "Guidance Notes on Codes and Abbreviations" appearing at the beginning of each regular issue of the PCT Gazette.

Published:

— *with international search report*

A coin sorter apparatus and use of such apparatus

BACKGROUND OF THE INVENTION

5 The invention relates to a coin sorter apparatus according to the precharacterizing clause of Patent Claim 1. The invention applies but is not limiting to the coin sorter apparatus manufacturing industry. The invention also relates to the use of such a coin sorter
10 apparatus.

Coin sorter apparatuses are used in, inter alia, systems for automatic coin handling. The coin sorter apparatuses are used in, for example, coin changers or
15 other cash systems. Examples of the area of application of such cash systems can be found within trade and in stores. These cash systems provide safer and more rapid coin handling for both personnel responsible for cash and customers; see, for example, US 5 562 536 which
20 discloses a coin sorter construction.

Known constructions suffer from the disadvantages that they are bulky and complicated to handle. There are constructions with distribution tracks for distributing
25 the coins according to size, which tracks result in a bulky design of the construction and unnecessarily long transport distances for the coins. Known constructions are often made up of a large number of components, which makes manufacture more expensive.

30

SUMMARY OF THE INVENTION

One object of the present invention is to eliminate said disadvantages of known constructions.

35

It is also an object of the present invention to produce a coin sorter apparatus which requires little space in the vertical direction in order to facilitate

the handling of coins at a cash desk in, for example, a shop.

Another object of the invention is to produce a coin
5 sorter apparatus which sorts coins according to denomination, at the same time as the transport distance for the coins is shorter.

A further object of the invention is to produce a coin
10 sorter apparatus which sorts coins according to size in order to facilitate transport to, for example, a bank.

To achieve these objects, the coin sorter apparatus according to the present invention is characterized by
15 the features indicated in the characterizing part of Patent Claim 1.

The distribution means comprises a portion designed for receiving coins standing vertically on their edge by
20 means of a guide means arranged on the transport device. The aperture of the distribution means, adapted for distribution of the coins to at least one sorting unit, consists of a slot designed with steps. In this way, a number of coins can be accommodated side by side
25 at the same time as every coin is transported directly to the respective sorting unit at the moment of distribution itself.

The transport device is suitably coupled to a drive
30 unit in order to bring about transport of the coins along a plane extending parallel to the main extent of the distribution means and along said slot. This means that the design of the coin sorter apparatus can be less bulky than known constructions. The drive unit,
35 such as an electric motor, can advantageously be positioned in the transport device, which arrangement requires little space.

The transport device is preferably designed with a number of compartments, arranged one after another and without a bottom, the main extent of the compartments extending transversely to the longitudinal direction of the slot and each compartment being designed so as to be capable of accommodating at least one coin. In this way, in each compartment, every coin can rest vertically on its edge against the distribution means before the coin is distributed. This means that the design of the transport device can be less bulky than known art at the same time as a number of coins for sorting and transport can be accommodated in the transport device. As coin sorter apparatuses are suitably designed with a coin insertion slot for receiving coins edge first, the guidance of the coin is carried out directly into a position in which it can rest upright with its edge directly against the distribution means. An additional guide for bringing about sorting of the coin is no longer necessary.

The guide means is advantageously driven in a direction along the slot designed with steps in such a manner that, in a first position, the coins come to lie at a first step with a width which is greater than the diameter of the coin with the smallest diameter but smaller than the diameter of the other coins. The coin with the smallest diameter thus falls into a first sorting unit, and other coins are transported onward for sorting.

A sensor is preferably positioned at the coin insertion slot in order to sense every coin dropped down. When the sensor, which is connected to a computer, senses that a coin has passed down to the distribution means, the computer gives a signal to a control unit to drive the transport device a distance corresponding to the spacing between two adjacent compartments.

Advantageously, a second step has a width which is greater than the diameter of the coin with the next smallest diameter but smaller than the diameter of other coins except the coins with the smallest and the next smallest diameter. In this way, coins with the next smallest diameter can be sorted into a second sorting unit.

Suitably, subsequent steps have a width which becomes greater for each step, the width of the step being adapted according to the respective diameter of the coin to be sorted. In this way, all sizes of coin in a currency can be sorted. This means that coins can also be sorted according to denomination and each sorting unit receives a specific denomination. As the sorting units are positioned adjacent to one another in interaction with the slot designed with steps, the handling of the sorting units for, for example, personnel responsible for cash is also simplified in comparison with known art. The present invention also means that coins can be sorted according to size, that is to say if there are a number of sizes of coin for a denomination, which facilitates transport to, for example, a bank.

The distribution means is preferably a plane panel, in which the slot designed with steps in the panel describes a circular line. This solution means that the transport device can be designed as a carousel, the compartments of the carousel being guided along the slot designed with steps during operation for sorting the coins.

The slot designed with steps suitably has its main extent along an essentially straight line. In this way, the coins can be transported over sorting units positioned in a row. In the case of currencies with a number of denominations and sizes of coin, this embodiment can facilitate handling of the sorted coins

by, for example, personnel responsible for cash. The apparatus can, for example, be designed in such a manner that the personnel responsible for cash can reach the sorting units from one side.

5

The transport device advantageously consists of a chain with lugs arranged at a spacing from one another, the main extent of the lugs extending transversely to the longitudinal direction of the slot so as to form said
10 compartments. The transport device can thus be designed so as to be capable of being driven along the desired curvature of a slot designed with steps.

The sorting unit preferably comprises at least one
15 collecting container arranged removably under each step. By virtue of the fact that the collecting container is removable, personnel responsible for cash, for example, can take the sorted coins out in a simple manner. Other arrangements for the transport of sorted
20 coins instead of collecting containers can of course be arranged together with the sorting unit.

The number of steps is preferably the same as the number of sizes of diameter of the coins to be sorted.

25

The number of collecting containers and the number of steps is suitably eight. In this way, the coin sorter apparatus is adapted to the euro.

30 Said compartments are preferably designed with such a width, seen in the main direction of the slot, that at least two coins can be accommodated side by side with the flat sides towards one another. In this way, coins of thinner thickness can be accommodated in one and the
35 same compartment. The computer is set so as not to advance a compartment when a second sensor senses the thickness of coins which are so thin that two coins are accommodated in the same compartment. In this way,

space can be saved, the apparatus being less bulky than known constructions for coin sorting.

The slot is suitably continuous for sorting all the
5 coins in a currency. In this way, each coin can be guided along the slot and at the same time stand vertically on its edge at the guide means of the transport device.

10 BRIEF DESCRIPTION OF FIGURES

The invention will be explained below with reference to the drawings, in which:

15 FIG. 1 shows a diagrammatic perspective view of a coin sorter apparatus according to the present invention in a first embodiment;

FIG. 2 shows a diagrammatic plan view of a distribution
20 means in the form of a panel comprising a slot designed with steps;

FIG. 3 shows a diagrammatic plan view of a coin sorter apparatus according to the first embodiment;

25 FIG. 3a shows a diagrammatic plan view of compartments designed for two coins;

FIG. 3b shows diagrammatically a coin standing in the
30 slot according to the section A-A in FIG. 3;

FIG. 4 shows a diagrammatic plan view of a channel for sorting coins of different size but the same denomination;

35 FIG. 5 shows a diagrammatic side view of the channel in FIG. 4, and

FIG. 6 shows a diagrammatic plan view of a coin sorter apparatus according to a second embodiment.

DETAILED DESCRIPTION OF THE INVENTION

5

The invention will now be described as an illustrative embodiment. For the sake of clarity, components not significant for the invention have been omitted in the drawing.

10

FIGS 1-3 show a coin sorter apparatus 1 according to a first embodiment of the present invention. The coin sorter apparatus 1 comprises an opening 3 for coins 5 of different size, such as a coin insertion slot 7 for
15 coins 5 of different diameter.

A distribution means 9 in the form of a plane panel 11 comprises an area 13 forming an aperture 15, such as a continuous slot 19 designed with steps 17 and
20 describing a circular line C (see FIG. 2). The coin insertion slot 7 communicates with a transport device 21 which interacts with the panel 11 and is designed as a carousel 23 comprising a number of compartments 25 (only a few compartments are illustrated). The
25 compartments 25 are arranged in line one after another and do not have bottoms, so that coins 5, by virtue of the law of gravity, can pass through the plane panel 11 when the slot 19 is sufficiently wide. Each compartment 25 has an extent U (see FIG. 3) oriented transversely
30 to the longitudinal direction of the slot 19 and is designed so as to be capable of accommodating one coin 5 at a time (see FIG. 3).

A coin 5 for sorting is transported by means of a chute
35 27 arranged between the coin insertion slot 7 and the carousel 23 to a compartment 25 adjusted to receive the coin 5. A currency identification unit 26 is suitably positioned together with the coin insertion slot 7 in order to separate incorrect coins or coins belonging to

- 8 -

an incorrect currency. The adjustment of the compartments 25 of the carousel 23 relative to the panel 11 is brought about by means of, inter alia, a sensor 29 sensing a passing coin 5 and a drive unit 31, such as an electric motor 33, which electric motor 33 is controlled by a computer 35 arranged in the coin sorter apparatus 1. When the coin 5 has passed the sensor 29 connected to the computer 35 and comes to lie on a portion 37 designed for receiving coins 5, that is to say on a portion 37 of the panel 11 and in one of the compartments 25 of the carousel 23, the electric motor 33 is made to drive the carousel 23 through an angle α , so that an adjacent compartment 25 comes to lie in the correct position for receiving the next coin 5 to be sorted. The coin 5 stands vertically on the portion 37, resting with its rounded edge 39 in a groove 40 in the panel 11. The walls 41 of the compartment which accommodate the coin 5 serve as a guide means 43. In this embodiment, the portion 37 is formed by a part of the panel 11 and comprises an extension of the slot 19 with a width which is smaller than the diameter of any of the coins 5 to be sorted.

FIG. 2 shows a plan view of the panel 11 comprising a slot 19 designed with steps 17. The steps I, II, III and IV are adapted for distribution of the coins 5 to at least one sorting unit 45 (see FIG. 1). The sorting unit 45 consists of four collecting containers 46', 46'', 46''' and 46'''' (see FIG. 3 below), such as boxes, which are arranged removably in the apparatus 1. By means of handles 47 (see FIG. 1), personnel responsible for cash (not shown), for example, can pull out the boxes for removal of the sorted coins 5.

Step I defines a width of the slot 19 in a first position which is greater than the diameter of the coin 5' with the smallest diameter but at the same time smaller than the diameter of the other coins 5'', 5''', 5'''' and 5''''' (see FIG. 3) to be sorted. Step II

- 9 -

defines a width of the slot 19 which is greater than the diameter of the coin 5'' with the next smallest diameter but at the same time smaller than the diameter of the other coins 5''' and 5'''' for sorting apart from the coins 5' and 5'' with the smallest and, respectively, the next smallest diameter. Step III defines a width which is sufficiently large that the coins 5''' with the next largest diameter fall through but narrower than the diameter of the coin 5'''' with the largest diameter. Step IV is the step in which the coins 5'''' with the largest diameter can pass through the panel 11 on account of gravity.

FIG. 3 illustrates a plan view of a coin sorter apparatus 1 according to a first embodiment. The apparatus 1 is adapted for sorting coins 5 of four different diameters. A coin 5' with the smallest diameter has just been positioned in the coin insertion slot 7 by a customer (not shown). The sensor 29 senses that the coin 5' has come to lie within the portion 37 for receiving coins 5 and in one of the compartments 25 of the carousel 23. The coin 5' rests upright in an extension of the slot 19, which has a width smaller than the diameter of the coin 5'.

The computer 35 (see FIG. 1) sends a signal to a control unit (not shown) to rotate the carousel 23 through an angle z which is of such a size that the adjacent compartment 25' is advanced to the portion 37 for receiving the coin 5. The drive is effected by means of the electric motor 33 comprising a gear rim 49 which engages in teeth 51 arranged on the inner lateral surface of the carousel 23.

Reference number 55 defines a compartment in which another coin 5' with the smallest diameter was previously accommodated, which coin 5' is now lying in the collecting container 46'. Coins 5'', 5''' and 5'''' with the other three diameters are now on their way for

sorting into the three other collecting containers 46'', 46''' and 46'''''. Only a moment before, the coins 5'', 5''' and 5'''' were transported into their respective collecting containers 46'-46'''' by means of
5 the compartments 25', 25'' and 25'''.

FIG. 3a shows a plan view of compartments 28 designed for receiving and transporting two coins 5. This embodiment means that coins 5 with a great variation in
10 terms of thickness can be sorted in the apparatus 1 according to the present invention.

A second sensor 59 arranged at the coin insertion slot 7 is adapted to sense the thickness of the coin 5. The
15 sensor 59 is connected to a computer (not shown) which, via a control unit (not shown), controls the carousel 23 so as not to rotate when two coins 5 can be accommodated side by side in a compartment with the flat sides towards one another. In other words, when
20 the electric motor 33 has advanced a compartment 25 and two successively received coins 5, which are thin enough to be accommodated in one compartment, have come to lie in the receiving portion 37, no rotation of the carousel 23 takes place.

25

FIG. 3b shows a coin 5 standing in the slot 19 according to the section A-A in FIG. 3. The coin 5 is resting in the slot 19 on its edge at letter p (see also FIG. 3) and is guided by the transport device 21,
30 that is to say the carousel 23, along the slot 19 of the panel 11 until the slot 19 becomes so wide that the coin 5 falls down into the intended collecting container 46. That wall 41' of the compartment 25 behind the coin 5, seen in the direction of rotation,
35 therefore pushes the coin ahead of it during advance. The edge portion of the slot 19 is chamfered in order to increase the contact area between the coin 5 and the panel 11, wear of the panel 11 being reduced.

-11-

FIG. 4 illustrates a plan view of a channel 61 for sorting coins 5 of different size but the same denomination. In some currencies and in cases where it is desirable to have coins 5 of the same denomination but of different size in one and the same collecting container 46, the coin sorter apparatus 1 according to the present invention is provided with a channel 61 for transporting the coin 5 to the intended collecting container 46.

10

The coins 5' have previously been sorted by means of a first step I of the slot 19, while the coin 5'''' is guided by means of the carousel 23 along the slot 19 until the slot 19 is so wide that the coin 5'''' falls down into the channel 61 and then rolls back into a position under the first step I and down into the intended collecting container 46. FIG. 5 shows a side view of the channel 61 in FIG. 4. FIG. 5 shows clearly that the channel 61 has an inclination so as to bring about transport of the coin 5'''' into the intended collecting container 46.

20

FIG. 6 illustrates a plan view of a coin sorter apparatus 1 according to a second embodiment. According to this embodiment, a panel 11', that is to say the distribution means 9, is provided with a slot 19', with a curvature C in part, and with a main extent along a straight line in part. The collecting containers 101-108 intended for sorted coins 5 are located under the straight section of the slot 19'. In this way, the coin sorter apparatus 1 can accommodate a large number of collecting containers, which is desirable as a currency may include a number of denominations and sizes of coin. The transport device 21 consists of a chain 63 with lugs 65 arranged at a spacing from one another. The main extent of the lugs 65 extends transversely to the longitudinal direction of the slot 19' designed with steps 17 so as to form compartments 25'. The lug 65, such as a rectangular plate, is attached to the

30

35

-12-

chain by riveting according to known art. Joining together can of course also be carried out by means of other types of connection, such as welding or screws. The attachment means that, in all positions, the lug
5 extends at right angles to the longitudinal direction of the chain 63.

Lugs 65 act as a guide means 43. In every compartment, a coin 5 for sorting is transported along the step-
10 shaped slot 19 of the distribution means 9. The distribution means 9 is a 3 mm thick plate secured by means of screws (not shown) in a frame (not shown) in the apparatus 1.

15 An electric motor 33 is fitted to a drive wheel 67, which drive wheel drives the chain 63 by means of teeth (not shown) for engagement in chain links (not shown) of the chain 63. The drive wheel 67 is mounted via a shaft 69.

20 The coin sorter apparatus 1 shown in FIG. 6 therefore comprises eight collecting containers 101-108. The number of steps is eight for eight different sizes of coin 5 in eight different denominations. The procedure
25 for advancing coins 5 takes place in a similar manner to that of the coin sorter apparatus 1 shown in FIG. 3. The coin insertion slot 7 and the sensor 29 are arranged at a support wheel 71. The support wheel 71 likewise comprises teeth (not shown) for receiving the
30 chain 63.

Other embodiments can also be produced within the scope of the invention. For example, pneumatic operation can be used instead of driving by electric motor. The
35 collecting containers can be arranged at one side of the apparatus, and the number of support wheels can of course be greater. The slot can follow an S-shaped curvature or be discontinuous in part.

PATENT CLAIMS

1. Coin sorter apparatus comprising at least one opening (3) for coins (5) of different size, at least
5 one distribution means (9) arranged in essentially horizontal extent and comprising an area (13) forming at least one aperture (15), which opening (3) communicates with a transport device (21) interacting with the distribution means (9), characterized in that
10 - the distribution means (9) comprises a portion (37) designed for receiving coins (5) standing vertically on their edge by means of a guide means (43) arranged on the transport device (21), and
- the aperture (15) of the distribution means (9),
15 adapted for distribution of the coins (5) to at least one sorting unit (45), consists of a slot (19) designed with steps (17).
2. Coin sorter apparatus according to Claim 1,
20 characterized in that the transport device (21) is coupled to a drive unit (31) in order to bring about transport of the coins (5) along a plane extending parallel along the main extent of the distribution means (9) and along said slot (19).
- 25
3. Coin sorter apparatus according to Claim 1 or 2, characterized in that the transport device (21) is designed with a number of compartments (25), arranged one after another and without a bottom, the main extent
30 (U) of the compartments (25) extending transversely to the longitudinal direction of the slot (19) and each compartment (25) being designed so as to be capable of accommodating at least one coin (5).
- 35
4. Coin sorter apparatus according to Claims 1-3, characterized in that the guide means (43) is driven in a direction along the slot (19) designed with steps (17) in such a manner that, in a first position, the coins (5') come to lie at a first step I with a width

which is greater than the diameter of the coin (5') with the smallest diameter but smaller than the diameter of the other coins.

5 5. Coin sorter apparatus according to Claim 4, characterized in that a second step II has a width which is greater than the diameter of the coin (5'') with the next smallest diameter but smaller than the diameter of other coins except the coins (5', 5'') with
10 the smallest and the next smallest diameter.

6. Coin sorter apparatus according to Claim 4, characterized in that subsequent steps have a width which becomes greater for each step, the width of the
15 step (17) being adapted according to the respective diameter of the coin (5) to be sorted.

7. Coin sorter apparatus according to any one of the preceding claims, characterized in that the
20 distribution means (9) is a plane panel, in which the slot (19) designed with steps (17) in the panel describes a circular line (C).

8. Coin sorter apparatus according to any one of the
25 preceding claims, characterized in that the slot (19) has its main extent along an essentially straight line.

9. Coin sorter apparatus according to any one of the preceding claims, characterized in that the transport
30 device (21) consists of at least one carousel (23).

10. Coin sorter apparatus according to any one of the preceding claims, characterized in that the transport device (21) consists of at least one chain (63) with
35 lugs (65) arranged at a spacing from one another, the main extent of the lugs (65) extending transversely to the longitudinal direction of the slot (19) so as to form said compartments (25).

11. Coin sorter apparatus according to any one of the preceding claims, characterized in that the sorting unit (45) comprises at least one collecting container (46) arranged removably under each step (17).

5

12. Coin sorter apparatus according to any one of the preceding claims, characterized in that the number of collecting containers (46) and the number of steps (17) is eight.

10

13. Coin sorter apparatus according to any one of the preceding claims, characterized in that said compartments (25) are designed with such a width, seen in the main direction of the slot (19), that at least two coins (5) can be accommodated side by side with the flat sides towards one another.

15

14. Use of a coin sorter apparatus (1) according to Claims 1-13, characterized in that a coin sorter apparatus (1) is used in systems for automatic coin handling.

20

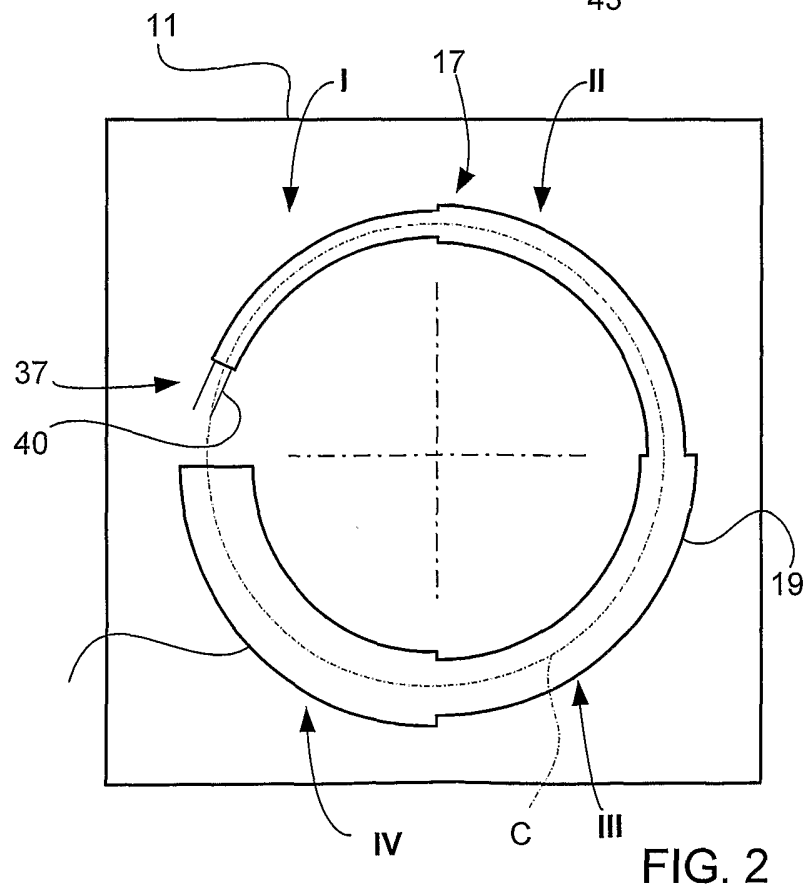
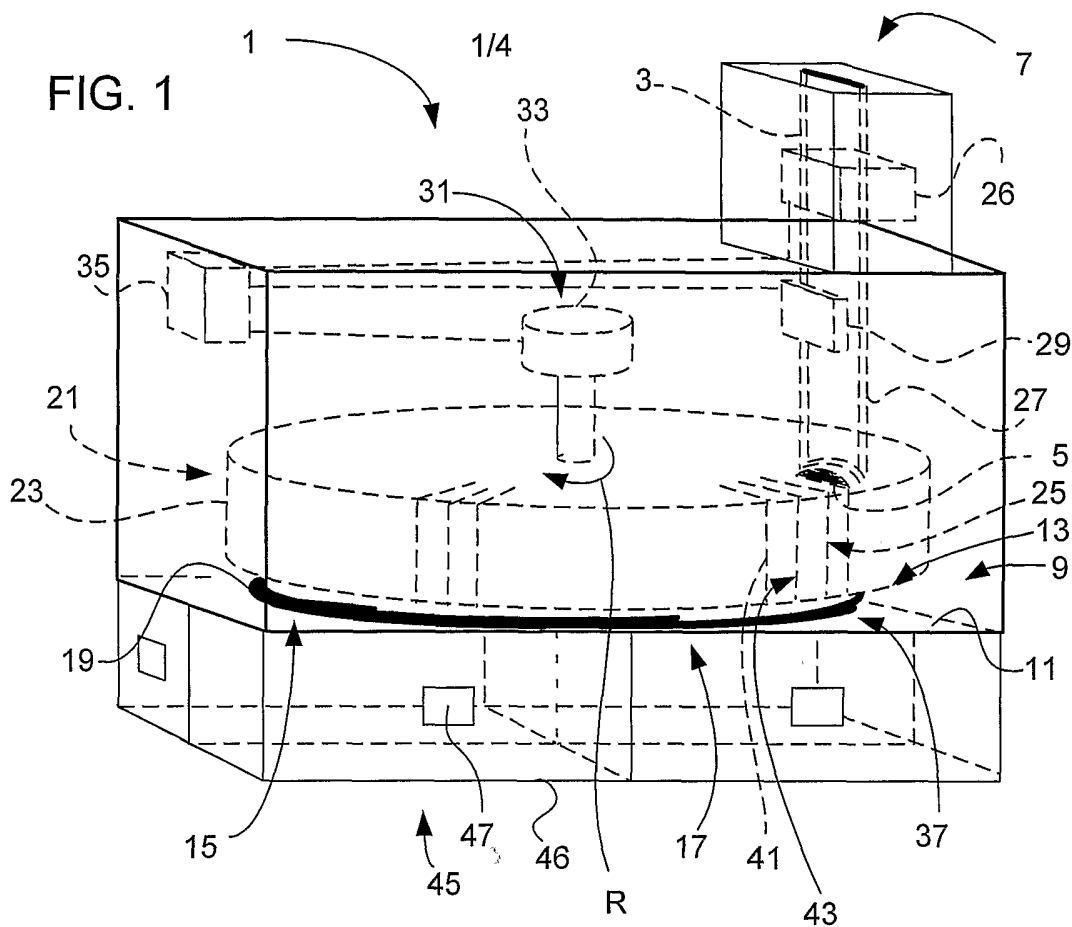

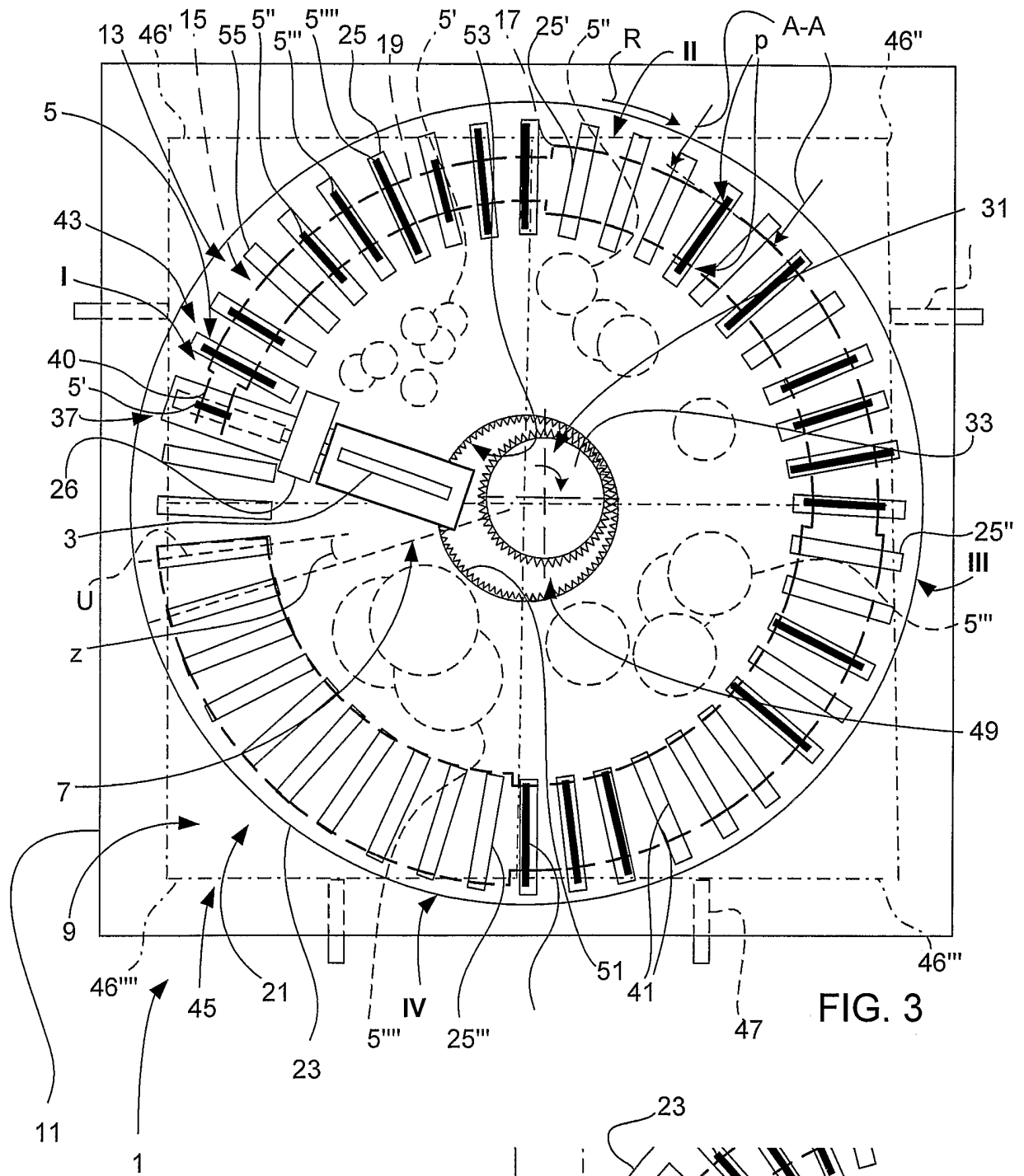

FIG. 3

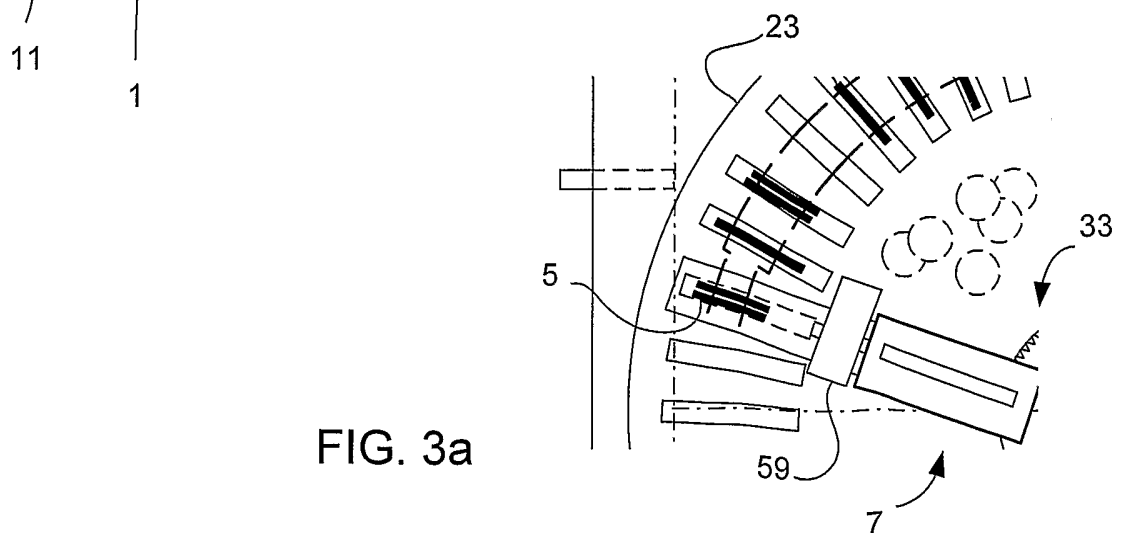
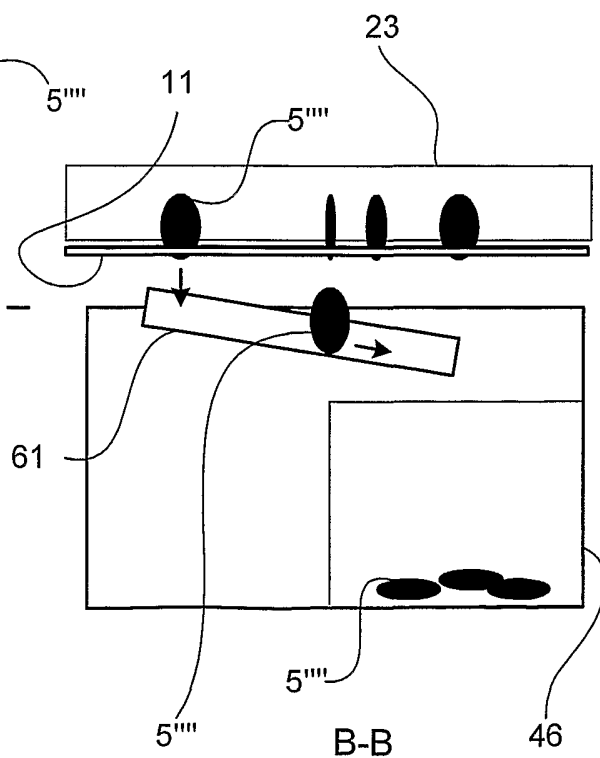
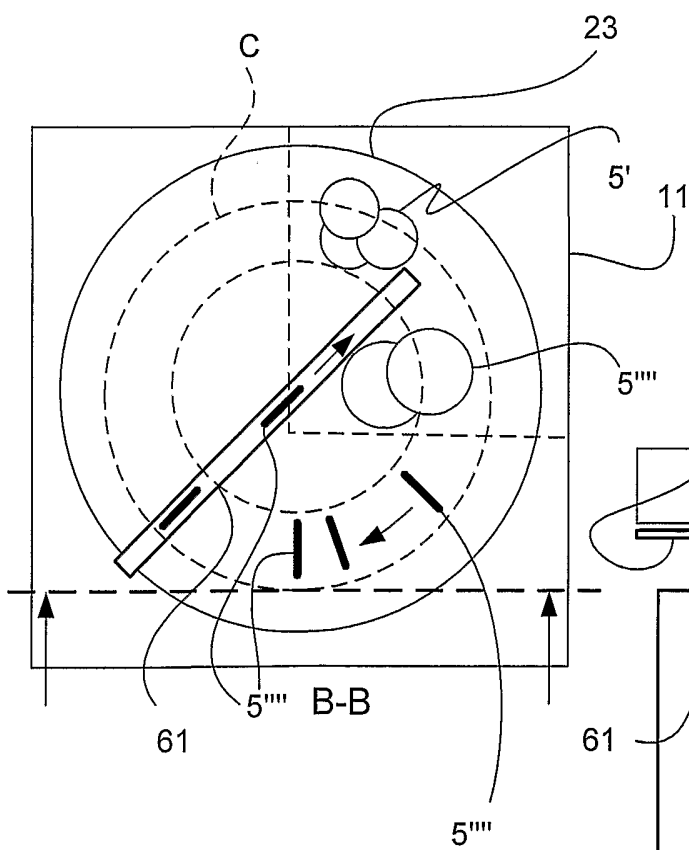
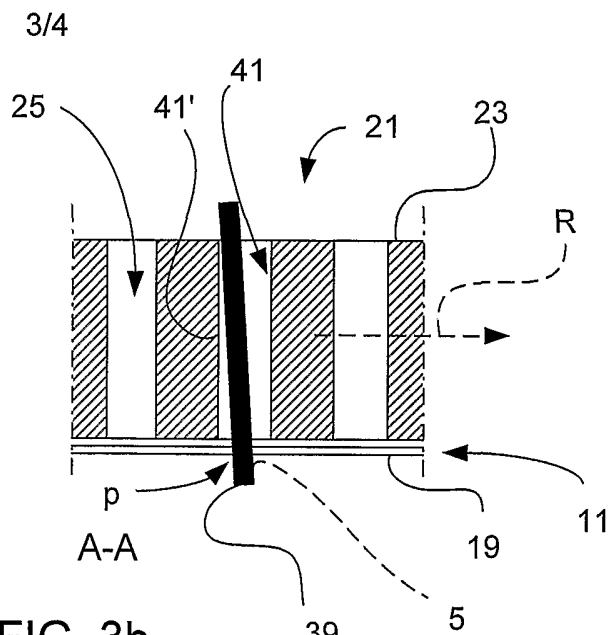

FIG. 3a



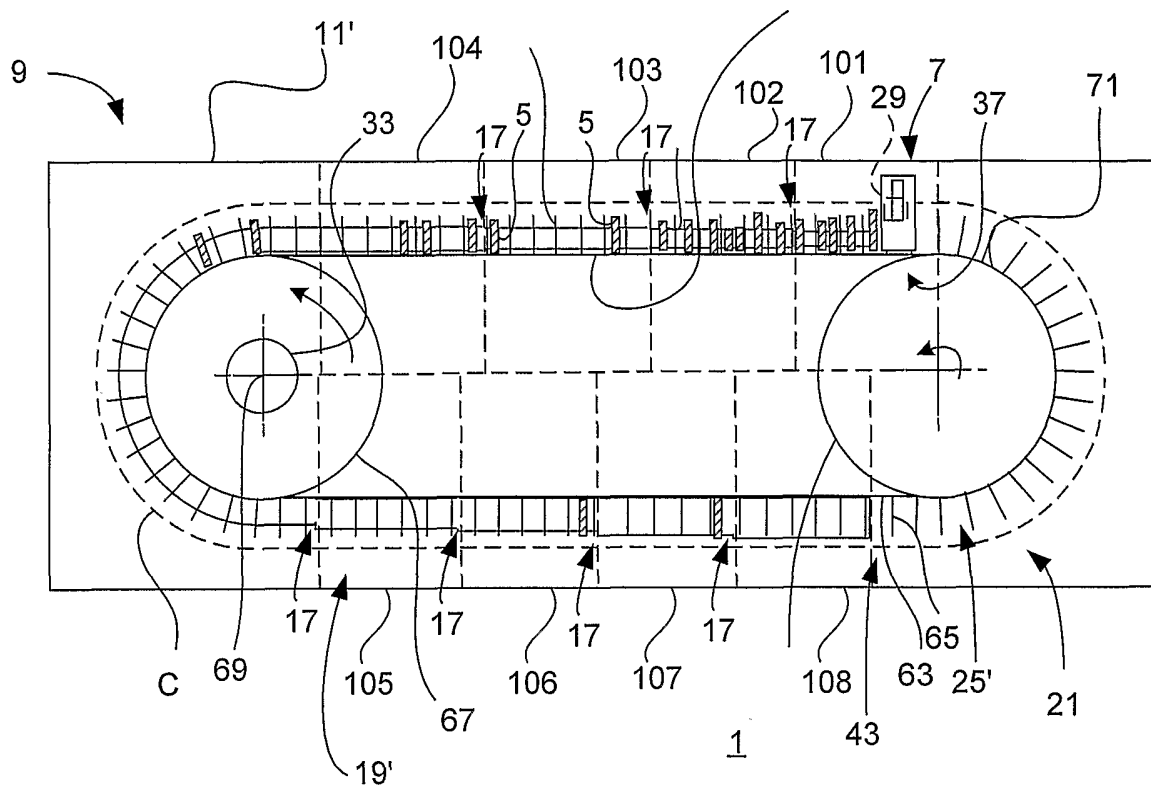

FIG. 6

INTERNATIONAL SEARCH REPORT

International application No.

PCT/SE 02/00604

A. CLASSIFICATION OF SUBJECT MATTER

IPC7: G07D 3/02, G07B 15/00

According to International Patent Classification (IPC) or to both national classification and IPC

B. FIELDS SEARCHED

Minimum documentation searched (classification system followed by classification symbols)

IPC7: G07D, G07B

Documentation searched other than minimum documentation to the extent that such documents are included in the fields searched

SE,DK,FI,NO classes as above

Electronic data base consulted during the international search (name of data base and, where practicable, search terms used)

EPO-INTERNAL, WPI DATA, PAJ

C. DOCUMENTS CONSIDERED TO BE RELEVANT

Category*	Citation of document, with indication, where appropriate, of the relevant passages	Relevant to claim No.
X	US 3930512 A (WOODLAND), 6 January 1976 (06.01.76)	1,8,11,14
A	--	2-7,9-10, 12-13
A	WO 9730423 A1 (THORN TRANSIT SYSTEMS INTERNATIONAL LIMITED), 21 August 1997 (21.08.97)	1-14
A	US 3434482 A (G. ZIMMERMANN), 25 March 1969 (25.03.69)	1-14

 Further documents are listed in the continuation of Box C.
 See patent family annex.

* Special categories of cited documents:

"A" document defining the general state of the art which is not considered to be of particular relevance

"E" earlier application or patent but published on or after the international filing date

"L" document which may throw doubts on priority claim(s) or which is cited to establish the publication date of another citation or other special reason (as specified)

"O" document referring to an oral disclosure, use, exhibition or other means

"P" document published prior to the international filing date but later than the priority date claimed

"T" later document published after the international filing date or priority date and not in conflict with the application but cited to understand the principle or theory underlying the invention

"X" document of particular relevance: the claimed invention cannot be considered novel or cannot be considered to involve an inventive step when the document is taken alone

"Y" document of particular relevance: the claimed invention cannot be considered to involve an inventive step when the document is combined with one or more other such documents, such combination being obvious to a person skilled in the art

"&" document member of the same patent family

Date of the actual completion of the international search

4 June 2002

Date of mailing of the international search report

10 -07- 2002

 Name and mailing address of the ISA/
 Swedish Patent Office
 Box 5055, S-102 42 STOCKHOLM
 Facsimile No. +46 8 666 02 86

Authorized officer

 Per-Olof Warnbo / MRo
 Telephone No. +46 8 782 25 00

INTERNATIONAL SEARCH REPORT
 Information on patent family members

01/05/02

International application No.
 PCT/SE 02/00604

Patent document cited in search report	Publication date	Patent family member(s)	Publication date
US 3930512 A	06/01/76	NONE	
WO 9730423 A1	21/08/97	EP 0880758 A GB 2310306 A GB 9602894 D GB 9622094 D EP 0962898 A	02/12/98 20/08/97 00/00/00 00/00/00 08/12/99
US 3434482 A	25/03/69	DE 368642 C DE 1524707 A,B FR 1513003 A GB 1111636 A	08/02/23 17/12/70 09/02/68 01/05/68