

(19)



(11)

**EP 4 283 066 B1**

(12)

**EUROPEAN PATENT SPECIFICATION**

(45) Date of publication and mention of the grant of the patent:  
**02.04.2025 Bulletin 2025/14**

(51) International Patent Classification (IPC):  
**E04B 1/76 (2006.01)**

(21) Application number: **23170901.5**

(52) Cooperative Patent Classification (CPC):  
**E04B 1/7633**

(22) Date of filing: **01.05.2023**

**(54) FIXING DEVICE FOR PREFABRICATED FAÇADE INSULATION SHEET AND PREFABRICATED FAÇADE INSULATION SHEET COMPRISING SAID FIXING DEVICE**

BEFESTIGUNGSVORRICHTUNG FÜR VORGEFERTIGTE FASSADENISOLIERPLATTE UND VORGEFERTIGTE FASSADENISOLIERPLATTE MIT DIESER BEFESTIGUNGSVORRICHTUNG

DISPOSITIF DE FIXATION POUR FEUILLE D'ISOLATION DE FAÇADE PRÉFABRIQUÉE ET FEUILLE D'ISOLATION DE FAÇADE PRÉFABRIQUÉE COMPRENANT LEDIT DISPOSITIF DE FIXATION

(84) Designated Contracting States:  
**AL AT BE BG CH CY CZ DE DK EE ES FI FR GB GR HR HU IE IS IT LI LT LU LV MC ME MK MT NL NO PL PT RO RS SE SI SK SM TR**

(72) Inventor: **González Alonso, Ignacio**  
**28223 Pozuelo de Alarcon (Madrid) (ES)**

(30) Priority: **21.05.2022 ES 202230851 U**

(74) Representative: **Codoñer Molina, Vicente**  
**Oficina Molina Patentes y Marcas, S.L.**  
**C/ Martí, 6 - Pta. 2.**  
**46005 Valencia (ES)**

(43) Date of publication of application:  
**29.11.2023 Bulletin 2023/48**

(56) References cited:  
**EP-A1- 3 279 485 CN-A- 113 789 871**

(73) Proprietor: **COVERWALL, S.L.**  
**28224 Pozuelo de Alarcon (Madrid) (ES)**

**EP 4 283 066 B1**

Note: Within nine months of the publication of the mention of the grant of the European patent in the European Patent Bulletin, any person may give notice to the European Patent Office of opposition to that patent, in accordance with the Implementing Regulations. Notice of opposition shall not be deemed to have been filed until the opposition fee has been paid. (Art. 99(1) European Patent Convention).

**Description****OBJECT OF THE INVENTION**

[0001] The present invention belongs to the field of construction, and more particularly to the installation of an outer insulation layer on the façade of a building.

[0002] The object of the present invention is a new fixing device specially designed to allow fast and safe fixing of a prefabricated insulation sheet on the façade of a building.

[0003] The invention also describes a prefabricated insulation sheet comprising at least one part of said fixing device.

**BACKGROUND TO THE INVENTION**

[0004] In the field of construction the arrangement on the outer surface of the façade of buildings or houses of a finish intended to insulate the interior of the house as much as possible from the inclement weather is known. The different ways of insulating the façades of buildings from the outside are known as ETIS (External Thermal Insulation System). Among the various types of existing ETIS, each with different characteristics and installation procedures, protection is known by fixing an insulating layer to the façade that subsequently receives an external finish of mortar and other materials to brighten up the final external appearance.

[0005] Fig. 1 shows the different layers of such an insulation system on a façade, and Fig. 2 shows the result obtained.

- The first layer (100) is an adhesive mortar (a cement adhesive ) which is applied using a trowel. This layer will serve to level the wall to be protected and as an adhesive of the insulating sheet, to prevent this from sliding downwards.
- The second layer (200) is formed by insulating sheets of a material such as glass wool, rock wool, expanded or extruded polystyrene, which are characterized by having a very low thermal conductivity and a low density so as not to excessively overload the scheme. In order that these sheets glued to the wall do not tend to detach with the passage of time, since they are affected, among other things, by the wind, they are fitted with additional fixing devices (DF) in the form of a nail with a very large head anchored to the wall. These fixing devices (DF) are mandatory according to the corresponding European regulations.
- The third (300), fourth (400) and fifth (500) layers are respectively a mortar of good adhesion on the insulating sheet, a glass fibre mesh that is arranged on top of the mortar, and a second mortar layer that covers the glass fibre mesh. This composite material will give surface continuity to the system, and insulate the insulation from inclement weather.

- The sixth layer (600) is a finishing mortar, of the required fineness and colour, which is usually applied by trowel, or an exterior paint. The end result is a generally smooth wall.

[0006] The installation process of this type of insulation systems is carried out completely manually, so it is very laborious and time-consuming. The main steps are the following:

1. Erect a scaffold for the entire façade.
2. Apply a first coat of levelling/adherence mortar by hand, with trowel.
3. Install the sheets of insulating material.
4. Drill the wall to put in the fixing devices (DF)
5. Apply a second coat of mortar by trowel
6. Install the fibre mesh
7. Apply a third coat of mortar by the trowel to cover the fibre
8. Apply a fourth coat of primer
9. Apply a fifth coat of finishing mortar by trowel.
10. Lift up all the materials used.
11. Disassemble the scaffold.

[0007] Therefore, there is a need in this field of the art for insulation systems that can be installed in a faster and more convenient manner. In an exhaustive search for commercial products, no prefabricated solution has been found that does not require a laborious finish, since the fixing devices (DF) have to be fixed before the finishing layers.

[0008] From EP 3 279 485 A1 there is known an insulation anchor.

[0009] From CN 113 789 871 A1 there is known a heat preservation and decoration integrated template.

**DESCRIPTION OF THE INVENTION**

[0010] The inventor of the present invention has developed a fixing device specially designed for fixing the insulation sheets on a façade. Advantageously, at least a part of this fixing device will be pre-installed on the insulation sheets by a previous industrial process. The installation of an insulation system formed by these sheets will be much faster and simpler compared to known conventional systems. To allow its pre-installation on the sheets, the fixing device has a design composed of two physically differentiated elements that fit together and that are particularly designed for this purpose.

[0011] In this document, the terms "*distal*" and "*proximal*" are to be interpreted according to the meaning they usually have in the field of medicine. In particular, the term "*proximal*" refers to the side or end of an element that is closest to the person handling it, while the term "*distal*" refers to the side or end of an element that is farthest from the person handling it.

[0012] Herein, the term "*longitudinal*" refers to the main direction along which the elements forming the fixing

device of the invention extend. Thus, in the natural position of the fixing device once the sheet has been installed on a wall, the longitudinal direction is perpendicular to the wall. In just the same way, the term "transverse" refers to any direction perpendicular to said longitudinal direction. That is, when the sheet is installed on a wall, any direction contained in a plane parallel to said wall is a transverse direction.

[0013] In this document, the "inner surface" of the sheet of the invention, or of any of its layers, refers to the surface of said sheet or layer that is oriented towards the façade on which it is to be installed. Similarly, the "outer surface" of one such sheet or layer refers to the surface that is oriented in the opposite direction to the façade on which it is to be installed. Therefore, taking into account the definition of the terms "proximal" and "distal", as well as the orientation adopted by the device of the invention pre-installed inside the sheet, generally the inner surface of the sheet may be referred to as "distal surface", and the outer surface of the sheet may be referred to as "proximal surface".

[0014] The invention is a fixing device for a prefabricated façade insulation sheet, i.e. for fixing an insulation sheet on the façade of a dwelling or building, according to claim 1. The fixing device basically comprises two elements: a stud and a stem. Each of these elements is defined in greater detail below.

#### a) Stud

[0015] It is a stud comprising a head in a proximal position and a body in a distal position that protrudes transversely relative to the body. That is, the stud has a structure that can be considered similar to that of a screw or nail, with an elongated body having at a proximal end a wider head protruding in a direction transverse to the main direction of the body. Thus, as will be described hereinafter, in order to use the device of the invention, firstly, the stud is introduced into the insulating sheet to be fixed. The body is embedded in the sheet perpendicular to the plane of the sheet itself, and the wider head prevents the body from completely crossing the sheet, thus anchoring the device to it. The head may in principle have different shapes, but preferably has an essentially circular planar shape which in this field is known as a "rosette" shape.

[0016] In principle, the shape of the outer surface of the body can be any elongated shape that allows carrying out the described function, that is, introducing or "nailing" the body in the insulating sheet. For example, the outer surface of the body could be prismatic with a hexagonal base or the like, or slightly conical to facilitate its anchoring to the sheet. However, in a particularly preferred embodiment of the invention, the outer surface of the stud body is cylindrical in shape. According to an even more preferred embodiment, a distal portion of the body, i.e. the tip region of the body, has a shape that tapers distally. This embodiment could be advantageous to facilitate the introduction

of the stud into the insulating sheet.

[0017] The stud further comprises a first longitudinal through-hole of decreasing cross-section in the distal direction. In this context, the term "tapering cross-section" encompasses any shape of the hole in which its cross-section tapers towards the tip, either progressively or in a punctual manner by means of a straight step (i.e. perpendicular to the longitudinal direction) or by means of a conical portion. The purpose of this narrowing is to anchor the stem inside the first longitudinal hole, in the sense of preventing the stem from passing completely through said first longitudinal hole until leaving the distal end of the stud. As will be described below, the shape of the outer surface of the stem is complementary to the shape of the inner surface of the first hole of the stud and the narrowing, in any of its possible forms, causes the stem to enter only up to a certain point where it is blocked and practically forms a single piece with the stud.

#### b) Stem

[0018] The stem comprises a proximal portion and a distal portion traversed by a second longitudinal bore.

[0019] The second longitudinal hole is configured to receive a screw in a manner similar to that of a conventional stud of the type used for anchoring screws or the like to a wall. It is, therefore, a hole usually cylindrical in shape and whose diameter will adjust to the diameter of the screw to be inserted.

[0020] The proximal portion has an outer surface of decreasing cross-section in a distal direction configured to fit into the first longitudinal hole of the stud so that, when said proximal portion of the stem fits in said longitudinal hole, at least the distal portion of the stem protrudes distally from the stud. That is, as mentioned above, the shape of the outer surface of the proximal portion of the shaft and the shape of the inner surface of the stud hole are complementary. Thus, since both include a taper, be it of any type, the stem can only be introduced into the stud a certain distance from that which it is locked inside. The shape of the first hole of the stud and the proximal portion of the stem are designed so that it is locked inside the stud in a position such that its distal portion protrudes from the distal end of the stud. The first longitudinal hole of the stud and the outer surface of the proximal portion of the stem are conical in shape.

[0021] For its part, the distal portion of the stem is configured to open when a screw is inserted along the second longitudinal hole to be anchored to a hole drilled in a wall. That is to say, the distal portion of the stem has a structure similar to that of a stud according to the conventional meaning of the term, in which the introduction of the screw causes the opening of wings, grooves, ribs or the like that prevent it, once introduced into a wall, from being able to be extracted again. Preferably, the shape of the distal portion of the stem is essentially cylindrical, although it is also possible to have a small taper.

[0022] This device thus allows the prefabricated insu-

lation sheets to be fixed to the wall in question in a very fast and simple way. Normally, the prefabricated sheet will have a series of stud embedded in that sheet, as described above, in certain positions that ensure its correct fixing to the façade. For its installation, the sheet is presented in the desired position on the wall of the façade, on which the adhesion mortar has been previously applied, and then holes are drilled in the wall in the positions where the studs are located. The positions of these holes can be marked, for example, through the first longitudinal hole of each stud, or the drill bit can be directly inserted through said first longitudinal hole of each stud. Once the holes have been made and with the sheet placed in position so that they coincide with the positions of the studs, the corresponding stems are inserted until their respective proximal portions are fitted in the first longitudinal hole of each stud. In this position, the distal portion of each stem is housed inside the corresponding hole made in the wall. A suitably sized screw is then inserted through each stem until, as it traverses the distal portion that is housed in the hole in the wall, this distal portion opens and the screw anchored to said distal portion. The sheet is thus fixed to the façade in a fast and safe way.

**[0023]** The invention also describes a prefabricated façade insulation sheet comprising embedded therein at least one stud of a fixing device according to the type described above, oriented perpendicular to inner and outer surfaces of said prefabricated sheet, according to claim 7. That is, the sheet has preinserted a plurality of studs already ready to carry out the fixing of the sheet using the corresponding stems. The characteristics of the studs pre-inserted in the sheet are those described in the previous section.

**[0024]** Preferably, the prefabricated sheet comprises an insulation layer coated by at least one finishing layer. The insulating layer is responsible for thermally insulating the façade, while the finishing layer is responsible for providing the outer face of the sheet with an attractive aesthetic appearance. Thus, the insulating layer may be made of any insulating material commonly used in this field, such as for example EPS, rock wool, or others. Above this insulation layer is the finishing layer which, as is known, can in turn be formed by several sub-layers. For example, it may comprise a sub-layer formed of acrylic mortar reinforced with a mesh upon which a decorative sub-layer is laid.

**[0025]** In either case, according to this preferred embodiment of the invention, the stud is embedded in the sheet in such a way that a distal end of the body of said stud is essentially flush with the inner surface of said prefabricated sheet, and a proximal surface of the head of the stud is at least partially covered by the finishing layer. In this context, partially covered implies that, at most, only the first longitudinal hole of each stud is visible from the outer side of the sheet, the rest of the head of the stud being completely covered by the finishing layer. That is, the stud can have a length similar to the thickness of the

insulating layer of the sheet and be embedded in this insulating layer, its head being essentially flush with the outer surface of the insulating layer and, therefore, covered by the finishing layer. From the outside, only the first longitudinal holes of each stud would be visible so that the installer can subsequently insert the stems and screws during the installation process.

**[0026]** In another preferred embodiment of the invention, the sheet further comprises a stem housed inside the first longitudinal hole of each stud and, more preferably, also comprises a screw partially housed inside the second longitudinal hole of each stem. That is, it is possible to arrange in the prefabricated sheet a plurality of complete devices, including stud, stem and optionally also the corresponding screws partially inserted, which avoids the stems being lost if only the studs are pre-inserted. Naturally, the screws would only be inserted at a small distance that would not cause the distal portion of the stem to open.

**[0027]** Thanks to this configuration, the installation procedure of the prefabricated sheet described would be as follows. As mentioned, the sheet comprises pre-installed therein a plurality of studs configured to receive the corresponding stems and screws that allow the fixing of the sheet to the façade in question. These blocks can be embedded in the insulating layer of the sheet and its head covered with the finishing layer with the exception of the first longitudinal hole of each stud. This procedure basically comprises the following steps:

1. Place the prefabricated sheet on the façade to which it is to be attached.
2. Drill fixing holes in the façade through the first longitudinal hole of each stud.
3. Firmly insert respective stems through the first longitudinal hole of each stud.
4. Screw respective screws through the second longitudinal hole of each stem.

**[0028]** Naturally, the installation process may further involve additional steps known in this field. For example, before placing the prefabricated sheet on the façade, a guide rail can be fixed at the bottom of the façade and then spread a levelling adhesion mortar on the part of the façade where the sheet is to be fixed. A perimeter cord can also be extended over the inner surface of the sheet plus three adhesion mortar skins inside the cord. Additionally, after placement of the screws, the holes can be plugged with insulation material and an exterior finishing product, as well as sealing the joints between adjacent sheets also with the exterior finishing product.

## BRIEF DESCRIPTION OF THE DRAWINGS

**[0029]**

Fig. 1 shows a schematic view of the different layers that make up an outdoor thermal insulation system.

Fig. 2 shows in greater detail a fixing device used for fixing the insulating sheets of the external thermal insulation system.

Fig. 3 shows a perspective view of the elements comprising an example of a fixing device according to the present invention.

Fig. 4 shows the appearance of the fixing device when a screw has already been inserted into it.

Fig. 5 shows the exterior appearance of a prefabricated façade insulation sheet provided with a plurality of fixing devices embedded therein.

Fig. 6 shows a cross-section of a prefabricated sheet with a stud embedded therein

Fig. 7 shows a section of the fixing sheet where the position of the stud embedded therein can also be seen.

#### PREFERRED EMBODIMENT OF THE INVENTION

**[0030]** A particular example of device (1) according to the present invention is described below with reference to the attached figures.

**[0031]** Fig. 3 shows an exploded view of the fixing device (1) of the present invention where the different parts that comprise it can be seen. The device (1) is formed by a stud (2) and a stem (3).

**[0032]** The stud (2) is formed by a head (21) and a body (22) that are crossed by a first longitudinal hole (23). The body (22) has an outer surface of cylindrical shape, while the head (21) located at its proximal end has a shape commonly known as a "rosette". This shape essentially corresponds to a flat circular shape with rounded walls in the transition area with the cylindrical surface of the body (22) and with a flat proximal side perpendicular to the longitudinal direction.

**[0033]** The first longitudinal bore hole (23) has an essentially tapered shape that tapers from the proximal mouth to the distal mouth.

**[0034]** The stem (3) is formed by a proximal portion (31) and a distal portion (32) which are traversed by a second longitudinal hole (33). The proximal portion (31) has an outer surface having a tapered shape corresponding to the tapered shape of the first longitudinal hole (23) of the stud (2). Further, the proximal portion (31) has a length which is coincident with the length of the stud (2). Thus, when the stem (3) is inserted into the stud (2), the proximal portion (31) of the stem (3) is locked inside the first longitudinal hole (23). Furthermore, as both have the same length, the proximal end of the proximal portion (31) of the stem (3) is essentially flush with the proximal end of

the stud (2), and the distal end of the proximal portion (31) of the stem (3) is essentially flush with the distal end of the stud (2). The proximal portion (31) of the stem (3) is thus completely housed inside the first longitudinal hole (23) of the stud (2), thus both forming a single piece for practical purposes. In this situation, the entire distal portion (32) of the stem (3) protrudes through the distal end of the stud (2). This distal portion (32) has a structure similar to that of a conventional stud, that is, a structure configured to be anchored to a hole made in a wall when a screw (T) is introduced through the second longitudinal hole (33) of the stem (3). Finally, this shows that the second longitudinal hole (33) of the stem (3) is configured to receive the screw (T), and is therefore normally cylindrical.

**[0035]** Figures 5-7 show various views of a sheet (10) comprising a plurality of studs (2) pre-installed therein according to the present invention. As can be seen, the sheet (10) basically comprises two layers: an insulating layer (10a) and a finishing layer (10b). The insulating layer (10a) may be made of any suitable known material, such as rock wool. The finishing layer (10b) in this example is formed by two sub-layers, namely a first sub-layer (10b1) of acrylic mortar reinforced with a mesh and a second sub-layer (10b2) imitating a visible brick finish. As can be seen, the stud (2) is pre-installed in the insulating layer (10a) of the sheet (10). In particular, the body (22) of the stud (2) is completely embedded in said insulating layer (10a), the distal end of the body (22) being essentially flush with the inner surface of the sheet (10) and the head (21) being essentially flush with the outer surface of the insulating layer (10a). The finishing layer (10b) completely covers the head (21) of the stud (2) with the exception of the first longitudinal hole (23). As can be seen in Fig. 7, in this example where the aesthetic finish mimics visible brick, the position of the studs (2) is chosen so that the position of the first longitudinal hole (2) thereof lies in the space between two bricks, more particularly in a T-joint.

**[0036]** The pre-installation of the studs (2) inside the sheet (10) can be carried out in different ways.

**[0037]** For example, the studs (2) may be pre-installed in the insulation layer (10a) during the manufacture of the sheet (10) in the factory, and then the finishing layer (10b) applied with the desired characteristics (i.e., including one or the other sub-layers). The finishing layer (10b) can then be drilled in the positions where the studs (2) are, thus leaving the first longitudinal hole (23) of each stud (2) visible for the subsequent introduction of the stem (3) and the screw (T).

**[0038]** The prefabricated sheets (10) can thus be marketed, only with the studs (2) embedded, so that the stems (3) are provided separately. Alternatively, the stems (3) and optionally the screws (T) could also be partially inserted into the studs (2). In any case, once on site, a guide rail is first fixed at the bottom of the façade and then a levelling adhesion mortar is spread over the part of the façade where the sheet (10) is to be fixed. A perimeter cord can also be extended on the inner surface

of the sheet (10) plus three skins of adhesion mortar inside the cord. Once that is done, the sheet (10) is placed on the façade and fixing holes are drilled in the façade through the first longitudinal hole (23) of each stud (2). Respective stems (3) are then introduced thoroughly through the first longitudinal hole (23) of each stud (2), thus accommodating in the corresponding hole of the façade the distal portion (32) of each stem (3). Respective screws (T) are then screwed through the second longitudinal hole (33) of each stem (3) so that, when the screw (T) reaches the distal portion (32) of the stem (3), it causes the opening of the corresponding anchoring wings or structures. The fixing device (1), and therefore also the sheet (10), is thus firmly fixed to the façade. Finally, the process is completed by covering the holes through which the stem (3) and screw (T) have been inserted, or only the screw (T), with an insulating element plug and a filling of the same finishing material as the proximal part of the sheet (10), so that these holes are completely hidden.

### Claims

1. Fixing device (1) for a prefabricated façade insulation sheet, comprising:

a stud (2) comprising a head (21) in proximal position and a body (22) in distal position, the head (21) protruding transversely relative to the body (22) and the stud (2) comprising a first longitudinal through hole (23) of decreasing cross-section in distal direction; and

a stem (3) comprising a proximal portion (31) and a distal portion (32) crossed by a second longitudinal hole (33), wherein the proximal portion (31) has an outer surface of decreasing cross-section in a distal direction configured to fit in the first longitudinal hole (23) of the stud (2) such that, when said proximal portion (31) of the stem (3) is fitted into said longitudinal hole (23), at least the distal portion (32) of the stem (3) protrudes distally from the stud (2), the distal portion (32) of the stem (3) being configured to open when a screw (T) is inserted along the second longitudinal hole (33) to be anchored to a hole made in a wall,

**characterized in that** the first longitudinal hole (23) of the stud (2) has a conical shape tapering from a proximal mouth to a distal mouth and the proximal portion (31) of the stem (3) has a conical shape corresponding to said conical shape of the first longitudinal hole (23) of the stud (2), where a length of the proximal portion (31) of the stem (3) is coincident with a length of the stud (2),

such that, when the proximal portion (31) of the stem (3) fits into said longitudinal hole (23) of the

stud (2), the proximal end of the proximal portion (31) of the stem (3) is flush with the proximal end of the stud (2), and the distal end of the proximal portion (31) of the stem (3) is flush with the distal end of the stud (2).

2. Fixing device (1) according to claim 1, wherein an outer surface of the body (22) of the stud (2) is cylindrical in shape.
3. Fixing device (1) according to claim 2, wherein a distal portion of the outer surface of the body (22) of the stud (2) tapers distally.
4. Fixing device (1) according to any of the preceding claims, wherein the head (21) of the stud (2) has an essentially tapered shape.
5. Fixing device (1) according to any of claims 1-3, wherein the head (21) of the stud (2) has an essentially circular flat shape.
6. Fixing device (1) according to any of the preceding claims, wherein the distal portion (32) of the stem (3) has an essentially cylindrical shape.
7. A prefabricated façade insulation sheet (10) comprising embedded therein at least one stud (2) of a fixing device (1) according to any of the preceding claims oriented perpendicular to the inner and outer surfaces of said prefabricated sheet (10).
8. Prefabricated façade insulation sheet (10) according to claim 7, wherein the prefabricated sheet (10) comprises an insulation layer (10a) covered by at least one finishing layer (10b), a distal end of the body (22) of the stud (2) being essentially flush with the inner surface of said prefabricated sheet (10) and a proximal surface of the head (21) of the stud (2) being at least partially covered by the finishing layer (10b).
9. Prefabricated façade insulation sheet (10) according to any of claims 7-8, further comprising a stem (3) housed inside the first longitudinal hole (23) of each stud (2).
10. Prefabricated façade insulation sheet (10) according to claim 9, further comprising a screw (T) partially housed inside the second longitudinal hole (33) of the stem (3).
11. Prefabricated façade insulation sheet (10) according to any of claims 8-10, wherein the insulation layer (10b) is made of expanded polystyrene or rock wool.
12. Prefabricated façade insulation sheet (10) according to any of claims 8-11, where the finishing layer (10b)

is formed by several sub-layers (10b1, 10b2).

13. Prefabricated façade insulation sheet (10) according to claim 12, where the finishing layer (10b) comprises a first sub-layer (10b1) formed of acrylic mortar reinforced with a mesh upon which a second decorative sub-layer (10b2) is laid.
14. Prefabricated façade insulation sheet (10) according to claim 13, where the second decorative sub-layer (10b2) imitates a visible brick finish.

#### Patentansprüche

1. Befestigungsvorrichtung (1) für eine vorgefertigte Fassadenisolerplatte, umfassend:

einen Stift (2), der einen proximal gelegenen Kopf (21) und einen distal gelegenen Körper (22) umfasst, wobei der Kopf (21) schräg vom Körper (22) absteht und der Stift (2) ein erstes durchgehendes Längsloch (23) mit einem in distaler Richtung abnehmenden Querschnitt umfasst; und

einen Stamm (3), der einen proximalen Abschnitt (31) und einen distalen Abschnitt (32) umfasst, welche von einem zweiten Längsloch durchzogen sind, wobei der proximalen Abschnitt (31) eine Außenfläche mit einem in distaler Richtung abnehmenden Querschnitt aufweist, welche so ausgelegt ist, dass sie in das erste Längsloch (23) des Stiftes (2) passt, wodurch, wenn dieser proximale Abschnitt (31) des Stammes (3) in das Längsloch (23) eingesetzt wird, mindestens der distale Abschnitt (32) des Stammes (3) distal aus dem Stift (2) hervorragt, wobei der distale Abschnitt (32) des Stammes (3) so ausgebildet ist, dass er sich aufspreizt, wenn eine Schraube (T) entlang dem zweiten Längsloch (33) eingeführt wird, um in einem in der Wand gebohrten Loch verankert zu werden, **dadurch gekennzeichnet, dass** das erste Längsloch (23) des Stiftes (2) eine Kegelform aufweist, die sich von einem proximalen zu einem distalen Mund verjüngt, und der proximale Abschnitt (31) des Stammes (3) eine Kegelform aufweist, die der Kegelform des ersten Längsloches (23) des Stiftes (2) entspricht, wobei eine Länge des proximalen Abschnittes (31) des Stammes (3) einer Länge des Stiftes (2) entspricht,

sodass bei Einsetzen des proximalen Abschnittes (31) des Stammes (3) in das Längsloch (23) des Stiftes (2) das proximale Ende des proximalen Abschnittes (31) des Stammes (3) mit dem proximalen Ende des Stiftes (2) bündig abschließt und das distale Ende des proximalen

Abschnittes (31) des Stammes (3) mit dem distalen Ende des Stiftes (2) bündig abschließt.

2. Befestigungsvorrichtung (1) nach Anspruch 1, wobei eine Außenfläche des Körpers (22) des Stiftes (2) eine zylindrische Form aufweist.
3. Befestigungsvorrichtung (1) nach Anspruch 2, wobei sich ein distaler Abschnitt der Außenfläche des Körpers (22) des Stiftes (2) distal verjüngt.
4. Befestigungsvorrichtung (1) nach einem der vorhergehenden Ansprüche, wobei der Kopf (21) des Stiftes (2) eine im Wesentlichen angeschrägte Form aufweist.
5. Befestigungsvorrichtung (1) nach einem der Ansprüche 1-3, wobei der Kopf (21) des Stiftes (2) eine im Wesentlichen kreisförmige, flache Form aufweist.
6. Befestigungsvorrichtung (1) nach einem der vorhergehenden Ansprüche, wobei der distale Abschnitt (32) des Stammes (3) eine im Wesentlichen zylindrische Form aufweist.
7. Vorgefertigte Fassadenisolerplatte (10) umfassend mindestens einen darin eingebetteten Stift (2) einer Befestigungsvorrichtung (1) nach einem der vorhergehenden Ansprüche, welcher senkrecht zu den Innen- und Außenflächen der genannten vorgefertigten Platte (10) ausgerichtet ist.
8. Vorgefertigte Fassadenisolerplatte (10) nach Anspruch 7, wobei die vorgefertigte Platte (10) eine Isolierschicht (10a) umfasst, die von mindestens einer Deckschicht (10b) abgedeckt ist, wobei ein distales Ende des Körpers (22) des Stiftes (2) im Wesentlichen bündig mit der Innenfläche der vorgefertigten Platte (10) abschließt und eine proximale Fläche des Kopfes (21) des Stiftes (2) zumindest teilweise von der Deckschicht (10b) abgedeckt ist.
9. Vorgefertigte Fassadenisolerplatte (10) nach einem der Ansprüche 7-8, weiterhin umfassend einen Stamm (3), der innerhalb des ersten Längsloches (23) jedes Stiftes (2) aufgenommen ist.
10. Vorgefertigte Fassadenisolerplatte (10) nach Anspruch 9, weiterhin umfassend eine Schraube (T), die teilweise innerhalb des zweiten Längsloches (33) des Stammes (3) aufgenommen ist.
11. Vorgefertigte Fassadenisolerplatte (10) nach einem der Ansprüche 8-10, wobei die Isolierschicht (10b) aus geschäumtem Polystyrol oder Steinwolle besteht.
12. Vorgefertigte Fassadenisolerplatte (10) nach einem

der Ansprüche 8-11, wobei die Deckschicht (10b) aus mehreren Unterschichten (10b1, 10b2) besteht.

13. Vorgefertigte Fassadenisolerplatte (10) nach Anspruch 12, wobei die Deckschicht (10b) eine erste Unterschicht (10b1) aus mit Masche verstärktem Acrylmörtel umfasst, auf die eine zweite dekorative Unterschicht (10b2) aufgetragen ist.
14. Vorgefertigte Fassadenisolerplatte (10) nach Anspruch 13, wobei die zweite dekorative Unterschicht (10b2) eine sichtbare Ziegelbeschichtung nachahmt.

### Revendications

1. Dispositif de fixation (1) pour une feuille d'isolation de façade préfabriquée, comprenant :

un goujon (2) comprenant une tête (21) en position proximale et un corps (22) en position distale, la tête (21) dépassant transversalement par rapport au corps (22) et le goujon (2) comprenant un premier trou traversant longitudinal (23) de section décroissante dans le sens distal ; et

une tige (3) comprenant une partie proximale (31) et une partie distale (32) traversée par un second trou longitudinal (33), où la partie proximale (31) présente une surface extérieure de section transversale décroissante dans un sens distal configurée pour se loger dans le premier trou longitudinal (23) du goujon (2) de telle sorte que, lorsque ladite partie proximale (31) de la tige (3) est logée dans ledit trou longitudinal (23), au moins la partie distale (32) de la tige (3) dépasse de la partie distale du goujon (2), la partie distale (32) de la tige (3) étant configurée pour s'ouvrir lorsqu'une vis (T) est insérée dans le second trou longitudinal (33) afin d'être ancrée dans un trou percé dans un mur,

**caractérisé en ce que** le premier trou longitudinal (23) du goujon (2) présente une forme conique décroissante à partir d'une embouchure proximale jusqu'à une embouchure distale et que la partie proximale (31) de la tige (3) présente une forme conique correspondant à ladite forme conique du premier trou longitudinal (23) du goujon (2), où une longueur de la partie proximale (31) de la tige (3) coïncide avec une longueur du goujon (2),

de telle sorte que, lorsque la partie proximale (31) de la tige (3) se loge dans ledit trou longitudinal (23) du goujon (2), l'extrémité proximale de la partie proximale (31) de la tige (3) est alignée avec l'extrémité proximale du goujon (2), et l'extrémité distale de la partie proximale

(31) de la tige (3) est alignée avec l'extrémité distale du goujon (2).

2. Dispositif de fixation (1) selon la revendication 1, dans lequel une surface extérieure du corps (22) du goujon (2) présente une forme cylindrique.
3. Dispositif de fixation (1) selon la revendication 2, dans lequel une partie distale de la surface extérieure du corps (22) du goujon (2) présente un rétrécissement dans le sens distal.
4. Dispositif de fixation (1) selon l'une quelconque des revendications précédentes, dans lequel la tête (21) du goujon (2) présente une forme essentiellement conique.
5. Dispositif de fixation (1) selon l'une quelconque des revendications 1-3, dans lequel la tête (21) du goujon (2) présente une forme plate essentiellement circulaire.
6. Dispositif de fixation (1) selon l'une quelconque des revendications précédentes, dans lequel la partie distale (32) de la tige (3) présente une forme essentiellement cylindrique.
7. Une feuille d'isolation de façade préfabriquée (10) intégrant au moins un goujon (2) d'un dispositif de fixation (1) selon l'une quelconque des revendications précédentes orienté perpendiculairement aux surfaces intérieure et extérieure de ladite feuille préfabriquée (10).
8. Feuille d'isolation de façade préfabriquée (10) selon la revendication 7, dans laquelle la feuille préfabriquée (10) comprend une couche isolante (10a) recouverte d'au moins une couche de finition (10b), une extrémité distale du corps (22) du goujon (2) étant essentiellement alignée avec la surface intérieure de ladite feuille préfabriquée (10) et une surface proximale de la tête (21) du goujon (2) étant au moins partiellement recouverte par la couche de finition (10b).
9. Feuille d'isolation de façade préfabriquée (10) selon l'une quelconque des revendications 7-8, comprenant en outre une tige (3) logée à l'intérieur du premier trou longitudinal (23) de chaque goujon (2).
10. Feuille d'isolation de façade préfabriquée (10) selon la revendication 9, comprenant en outre une vis (T) partiellement logée à l'intérieur du second trou longitudinal (33) de la tige (3).
11. Feuille d'isolation de façade préfabriquée (10) selon l'une quelconque des revendications 8-10, dans laquelle la couche isolante (10a) est constituée de

polystyrène expansé ou de laine de roche.

- 12.** Feuille d'isolation de façade préfabriquée (10) selon l'une quelconque des revendications 8-11, où la couche de finition (10b) est constituée de plusieurs sous-couches (10b1, 10b2). 5
- 13.** Feuille d'isolation de façade préfabriquée (10) selon la revendication 12, où la couche de finition (10b) comprend une première sous-couche (10b1) formée de mortier acrylique renforcé par une maille sur laquelle une deuxième sous-couche décorative (10b2) est appliquée. 10
- 14.** Feuille d'isolation de façade préfabriquée (10) selon la revendication 13, où la deuxième sous-couche décorative (10b2) imite une finition en briques apparentes. 15

20

25

30

35

40

45

50

55

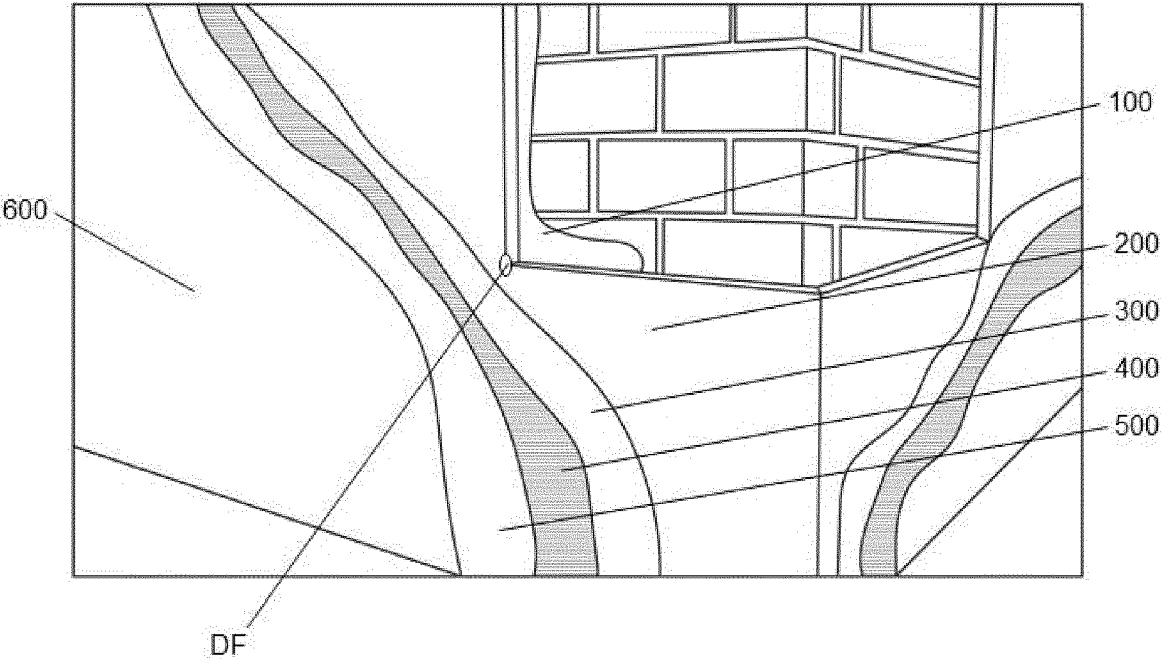

**FIG. 1**  
**PRIOR ART**

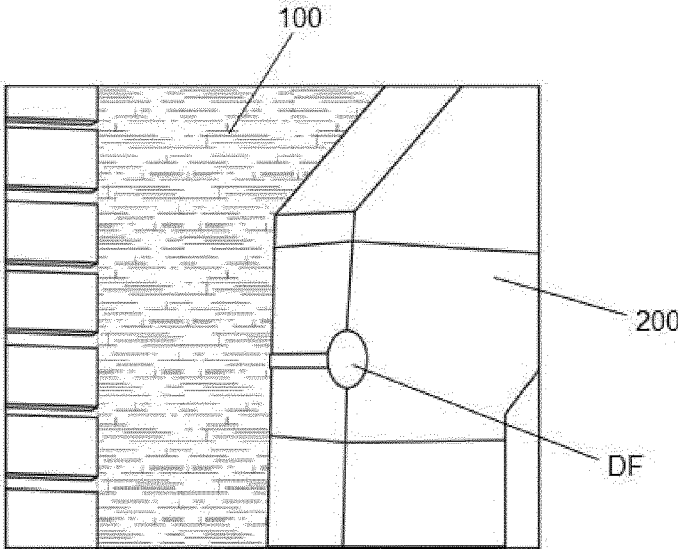

**FIG. 2**  
**PRIOR ART**

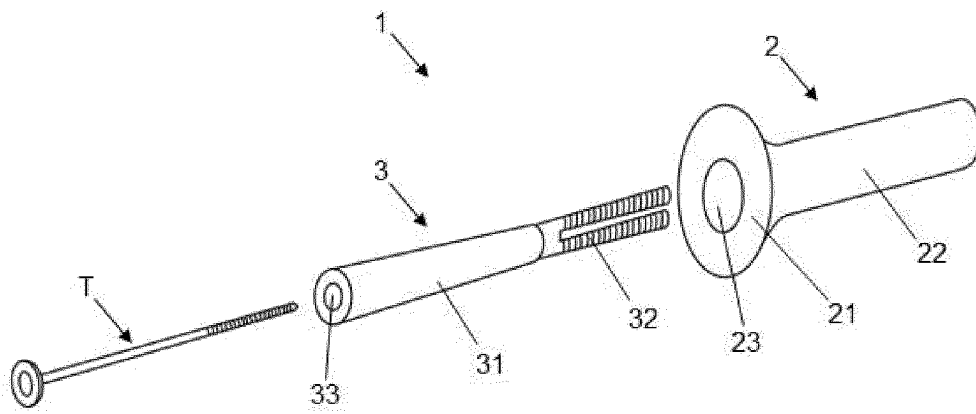

FIG. 3

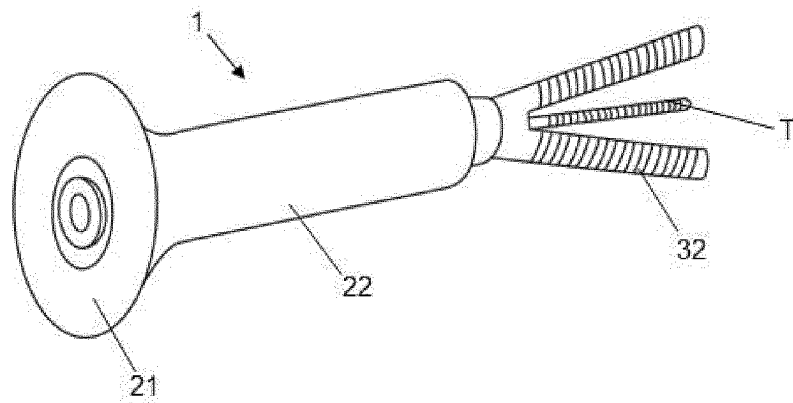

FIG. 4

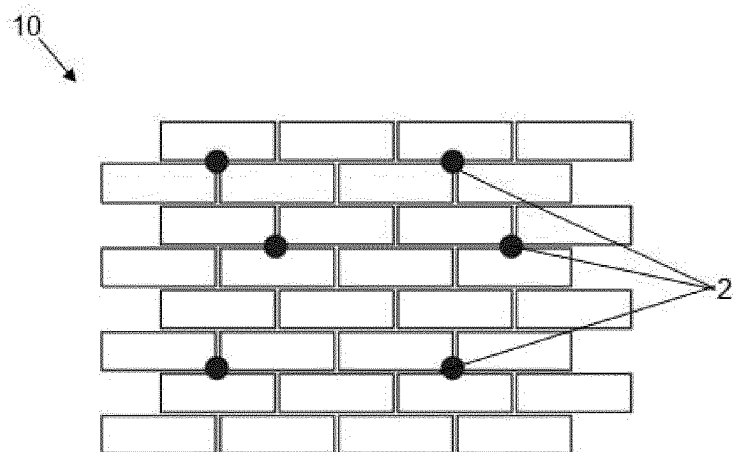

FIG. 5

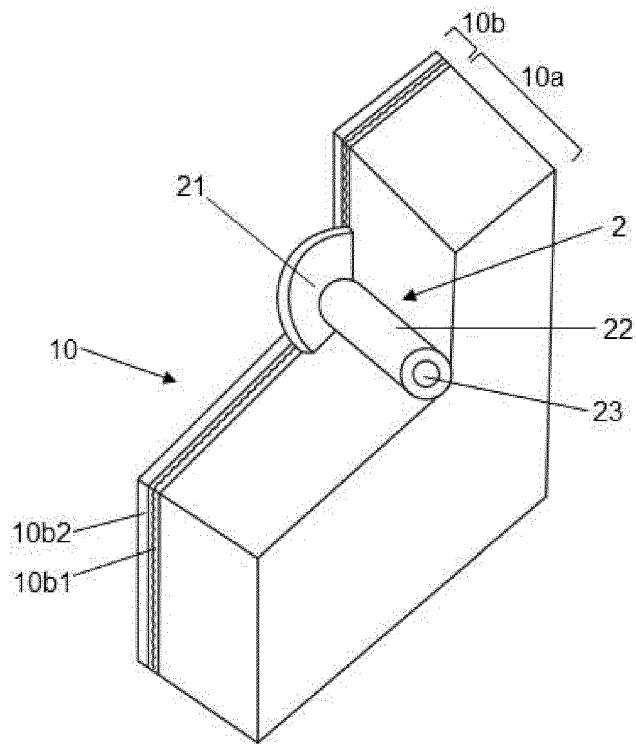

FIG. 6

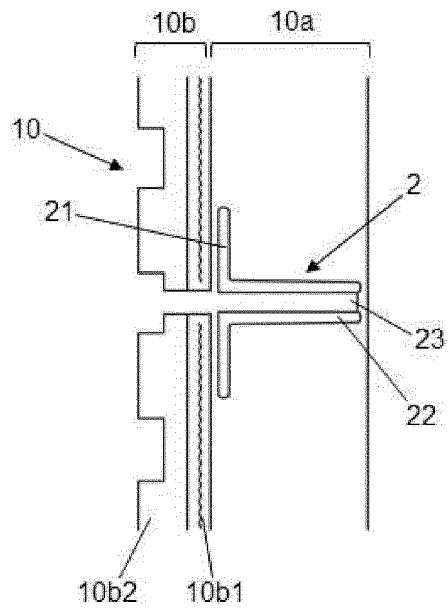

FIG. 7

**REFERENCES CITED IN THE DESCRIPTION**

*This list of references cited by the applicant is for the reader's convenience only. It does not form part of the European patent document. Even though great care has been taken in compiling the references, errors or omissions cannot be excluded and the EPO disclaims all liability in this regard.*

**Patent documents cited in the description**

- EP 3279485 A1 [0008]
- CN 113789871 A1 [0009]