

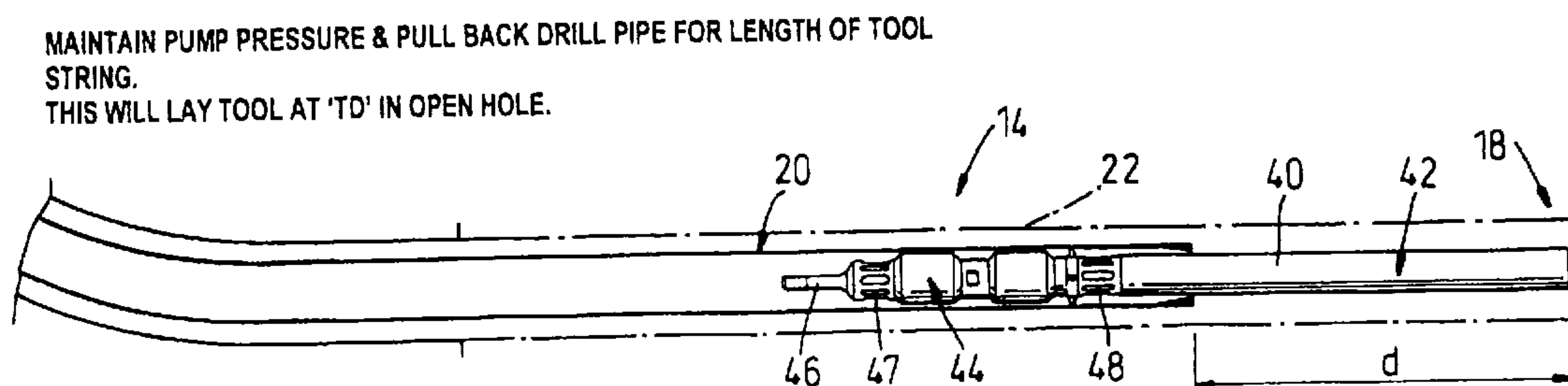

(72) MILNE, ALEX WATSON, GB
(72) SPENCER, MICHAEL CHARLES, GB
(71) REEVES WIRELINE TECHNOLOGIES LTD., GB
(51) Int.Cl.⁷ E21B 47/12
(30) 1998/11/28 (9826017.7) GB
(54) **METHODE ET APPAREIL DE DIAGRAPHIE DES SONDAGES**
(54) **WELL LOGGING METHOD & APPARATUS**



(57) A method of well logging in which the logging tool is delivered to the bottom of the well within a drill pipe and then the well is logged by withdrawing the drill pipe with the sensor portion of the logging tool protruding from the drill pipe. Following the logging operation the logging tool is returned to the surface by reverse circulation.

ABSTRACT**WELL LOGGING METHOD AND APPARATUS**

A method of well logging in which the logging tool is delivered to the
5 bottom of the well within a drill pipe and then the well is logged by
withdrawing the drill pipe with the sensor portion of the logging tool
protruding from the drill pipe. Following the logging operation the
logging tool is returned to the surface by reverse circulation.

10

Figure 5

WELL LOGGING METHOD & APPARATUS

The present invention relates to a well logging method and apparatus and more particularly to a method and apparatus which enables efficient and rapid logging of a well.

In oil and gas exploration it is extremely important to produce logs of each well in order that the oil/gas producer can assess the potential output of the well and know where to perforate.

Whilst such well logging is beneficial, it can be extremely expensive due to several factors, one of which is the time taken to produce the log.

When logging a well the drilling rig is required to stand idle from its drilling operation. The hire cost of such offshore rigs is very expensive and time taken to acquire data from conventional well logging of horizontal holes can be several days.

It is an object of the present invention to provide a well logging method and apparatus which enables a well to be logged in a much shorter time period than is possible with conventional methods.

It is a further object of the present invention to provide a well logging method and apparatus which is applicable to small diameter short length logging tools.

The present invention provides a method of well logging comprising the steps of:

a) inserting a battery powered memory logging device into a well borehole at a head end of said well, said well borehole containing a drill

pipe,

b) forcing said logging device to a position adjacent to the far end of said drill pipe, opposite to said head end, by means of pump pressure applied to said logging device, said pump pressure being applied
5 along said drill pipe from said head end,

c) maintaining pump pressure on said logging device,

d) pulling back on said drill pipe over a defined length whilst maintaining said pump pressure to force at least a portion of the logging tool containing logging sensors into the open borehole at the end of the
10 drill pipe,

e) pulling said drill pipe through said borehole towards said head end,

f) maintaining the pump pressure to maintain the position of the logging portion of the logging device protruding from the end of the drill
15 pipe,

g) logging the characteristics of the well with said logging device as said drill pipe is pulled through said well borehole.

Preferably the method further comprises the step of h) once logging of the borehole over a required distance has been completed, reversing the
20 pump pressure in said drill pipe such that pump pressure is applied to the end of said logging device furthest from said well head,

i) forcing said logging tool along said borehole towards said well head and,

j) catching said logging tool at a position adjacent said well head.

25 Preferably said method further comprises k) removing said logging device from said well head and down-loading said recorded logging data.

The invention also provides a well logging tool for use with the above method, said well logging tool comprising a first portion comprising well
30 logging sensors and a second portion comprising a retention portion, said

retention portion being provided with collar means for retaining said logging device within said drill pipe.

Preferably said retention portion of said well logging tool includes means
5 for passage of fluid through said tool.

Embodiments of the present invention will now be described, by way of example with reference to the accompanying drawings, in which:-

10 Figure 1 shows diagrammatically a typical gas or oil well,

Figure 2 shows diagrammatically a drill pipe end,

Figure 3 diagrammatically shows the head end of the well of figure
(in greater detail),

Figure 4 shows the logging tool at a first initial position at the
15 bottom of the drill pipe of the well of figure 1,

Figure 5 shows the logging tool at a second position at the bottom
of the drill pipe of the well of figure 1,

Figure 6 shows the logging tool at a third position at the bottom of
the drill pipe with the drill pipe moved away from the well end,

20 Figure 7 shows the logging tool in a fourth position with the drill
pipe moved further away from the well end,

Figure 8 shows the logging tool in a fifth position with the logging
tool in a sixth position being returned to the well head end by reverse fluid
pressure.

25

With reference now to the drawings, Figure 1 shows diagrammatically a well 10. The well will be typically an oil or gas well and may comprise a vertical portion 12 and possibly a horizontal portion 14. The well may extend for several thousand feet.

30

The well comprises a head end 16 and a "bottom" end 18. The term bottom end is used, but as can be seen from Figure 1, the well can extend horizontally or even turn slightly upwards. Thus, the term bottom is used to mean the opposite end of the well to the head end.

5

Figure 2 shows diagrammatically the bottom end of the well in greater detail. A drill pipe 20 is shown which reaches to the bottom end 18 of the well. The sides of the well are indicated at 22. The drill pipe will normally have a shoulder portion 24. As indicated by arrows 26, fluid, usually a carefully controlled mud mixture, is circulated down the central bore of the drill pipe 20 and back up the outside volume between the drill pipe and the side 22 of the borehole. The fluid may be supplied by fluid pump and reservoir means 17 (figure 1). The supply of fluid is well known in the control/drilling of boreholes and thus the supply system will not be described further.

10
15

Figure 3 shows diagrammatically the well head in greater detail. This comprises a catch portion 30 which is shown to be of undetermined length.

20

With reference now to Figure 4, a typical logging tool 40 is shown positioned at the bottom end 18 of the well.

The logging tool 40 has been previously positioned at the head end of the well and then by using the pump fluid pressure in the direction of arrow 26 the logging tool is forced down the drill pipe 20 until the end of the logging tool reaches the bottom end 18 of the well where its progress is halted as shown in figure 4.

25

In a preferred example, the logging tool comprises a first portion 42

30

comprising well logging sensors and calliper/drive systems, and a second portion 44 including a catch portion 46 which acts as a fishing neck.

5 The second portion 44 preferably includes means for allowing controlled fluid flow 26 through said portion fluid passing into openings 47 and out of openings 48 or vice versa. A full description of the fluid control section of tool 40 is provided in a co pending application filed on the same day as the present application and thus this description is hereby incorporated by way of reference.

10

The method of operation is as follows and is illustrated by figures 4 to 8. In Figure 4 the logging tool has been forced by fluid flow 26 to the bottom end 18.

15 Once the logging tool 40 has reached the bottom of the well the tool will be retained at the end of the drill pipe. The fluid pressure will then begin to build up on the end of the logging tool. The system is designed to allow pumping pressure to build to a predetermined limit which in a preferred embodiment is 100 p.s.i. At this pressure a differential valve
20 (not shown) will open in section 44 of logging tool 40 allowing the continuation of the flow 26 but now via the tool (see Figure 6).

The fluid flow pressure 26 is maintained and the drill pipe 20 is then moved back (Figure 5) towards the well head by a distance 'd' (or greater)
25 which causes the logging section 42 of logging tool 40 to protrude from the bottom end of the drill pipe 20.

The movement of the drill pipe is by conventional means and will not be described in detail.

30

As shown in Figure 6 calliper 45 will open when the logging section 42 of tool 40 enters the borehole 22 and then logging will commence with drill pipe 20 being pulled at a known rate towards the well head 16. Caliper control will be by using the Induction measurement and Casing
5 Collar Locator.

Logging of the open borehole 22 will then continue as the drill pipe is withdrawn until the casing shoe 23 is reached, at which stage the calliper arm 45 will close (Figure 7). Again by use of Induction measurement and
10 Casing Collar Locator.

The logging operation is then completed with the data being recorded inside the logging tool 40.

15 A repeat section can be made once the caliper has closed.

The mud flow '26' is then reversed as indicated by arrows 260 and this reverse mud flow will lift the tool string incorporating the logging device 40 and the device will be received and captured in holding device 30,23.

20 With appropriate reverse flow pressures, the tool string 40 may be received at the well head from a depth of 10,000 ft in approximately 50 minutes data can be downloaded in approximately 10 to 20 minutes.

25 The method according to the present invention has several advantages over known systems.

Firstly, by forcing the logging tool to the bottom of the well inside the drill pipe the tool is protected from any wash-out regions as it passes down
30 the pipe.

When the logging tool reaches the end of the drill pipe it is still fully within the drill pipe. The drill pipe is withdrawn from the logging tool, the logging tool thereby remaining stationary relative to the well. The
5 calliper and the sensing end of the logging tool will therefore not have to be forced into an open bore and therefore will be protected at all times.

By use of the differential valve means the fluid flow can be maintained during logging.

10

THE EMBODIMENTS OF THE INVENTION IN WHICH AN EXCLUSIVE PROPERTY OR PRIVILEGE IS CLAIMED ARE DEFINED AS FOLLOWS:

1. A method of well logging comprising the steps of:
 - a) inserting a battery powered memory logging device into a well borehole at a head end of said well, said well borehole containing a drill pipe,
 - b) forcing said logging device to a position adjacent to the far end of said drill pipe, opposite to said head end, by means of pump pressure applied to said logging device, said pump pressure being applied along said drill pipe from said head end,
 - c) maintaining pump pressure on said logging device,
 - d) pulling back on said drill pipe over a defined length whilst maintaining said pump pressure to force at least a portion of the logging tool containing logging sensors into the open borehole at the end of the drill pipe,
 - e) pulling said drill pipe through said borehole towards said head end,
 - f) maintaining the pump pressure to maintain the position of the logging portion of the logging device protruding from the end of the drill pipe,
 - g) logging the characteristics of the well with said logging device as said drill pipe is pulled through said well borehole.

2. A method of well logging as claimed in claim 1 in which the method further comprises the step of h) once logging of the borehole over a required distance has been completed, reversing the pump pressure in said drill pipe such that pump pressure is applied to the end of said logging device furthest from said well head,
 - i) forcing said logging tool along said borehole towards said well head and,

j) catching said logging tool at a position adjacent said well head.

3. A method of well logging as claimed in claim 2 in which said method further comprises k) removing said logging device from said well
5 head and down-loading said recorded logging data.

4. A well logging tool for use with the above method, said well logging tool comprising a first portion comprising well logging sensors and a second portion comprising a retention portion, said retention portion
10 being provided with collar means for retaining said logging device within said drill pipe.

5. A well logging tool as claimed in claim 4 in which said retention portion of said well logging tool includes means for passage of fluid
15 through said tool.

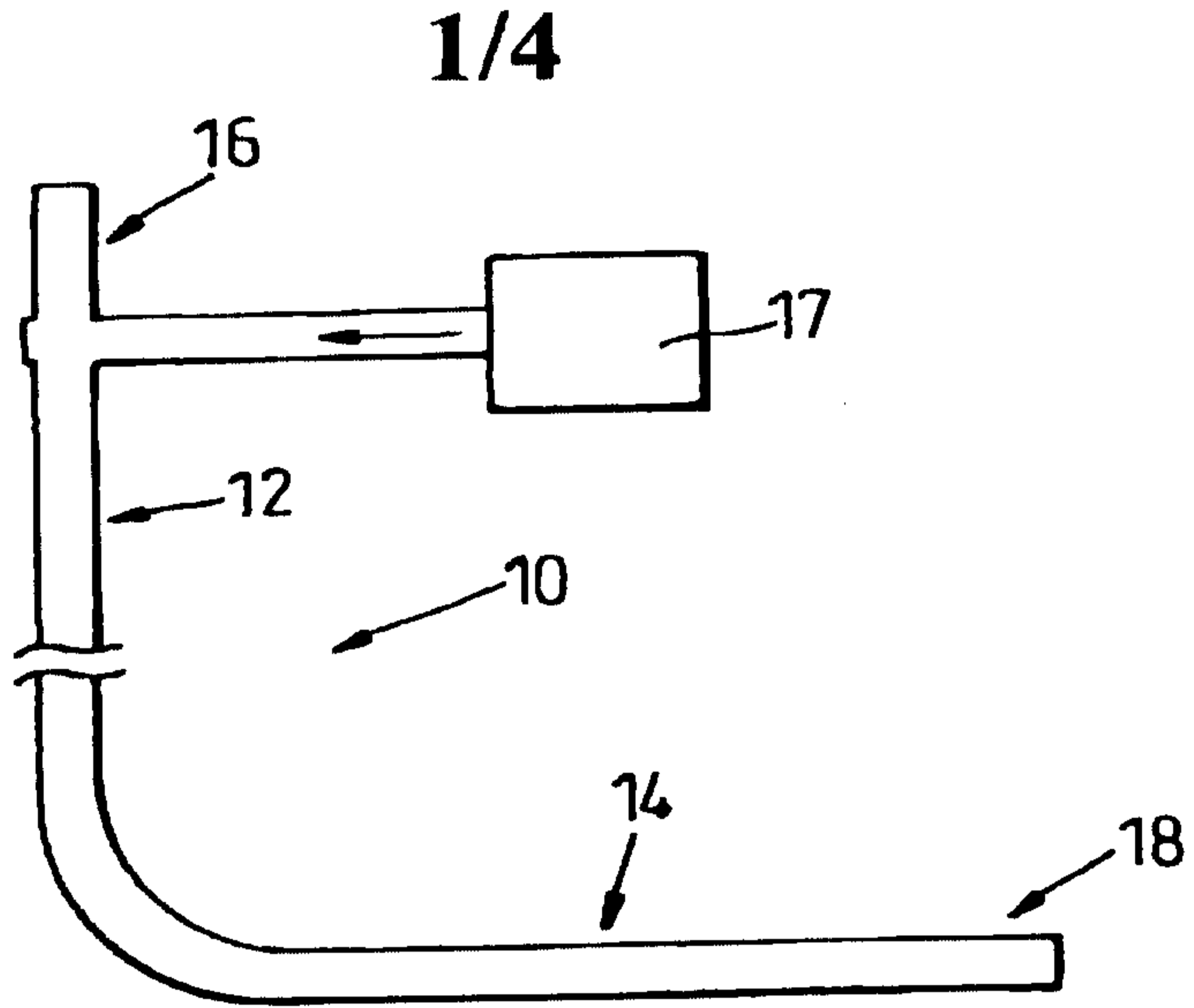

Fig. 1

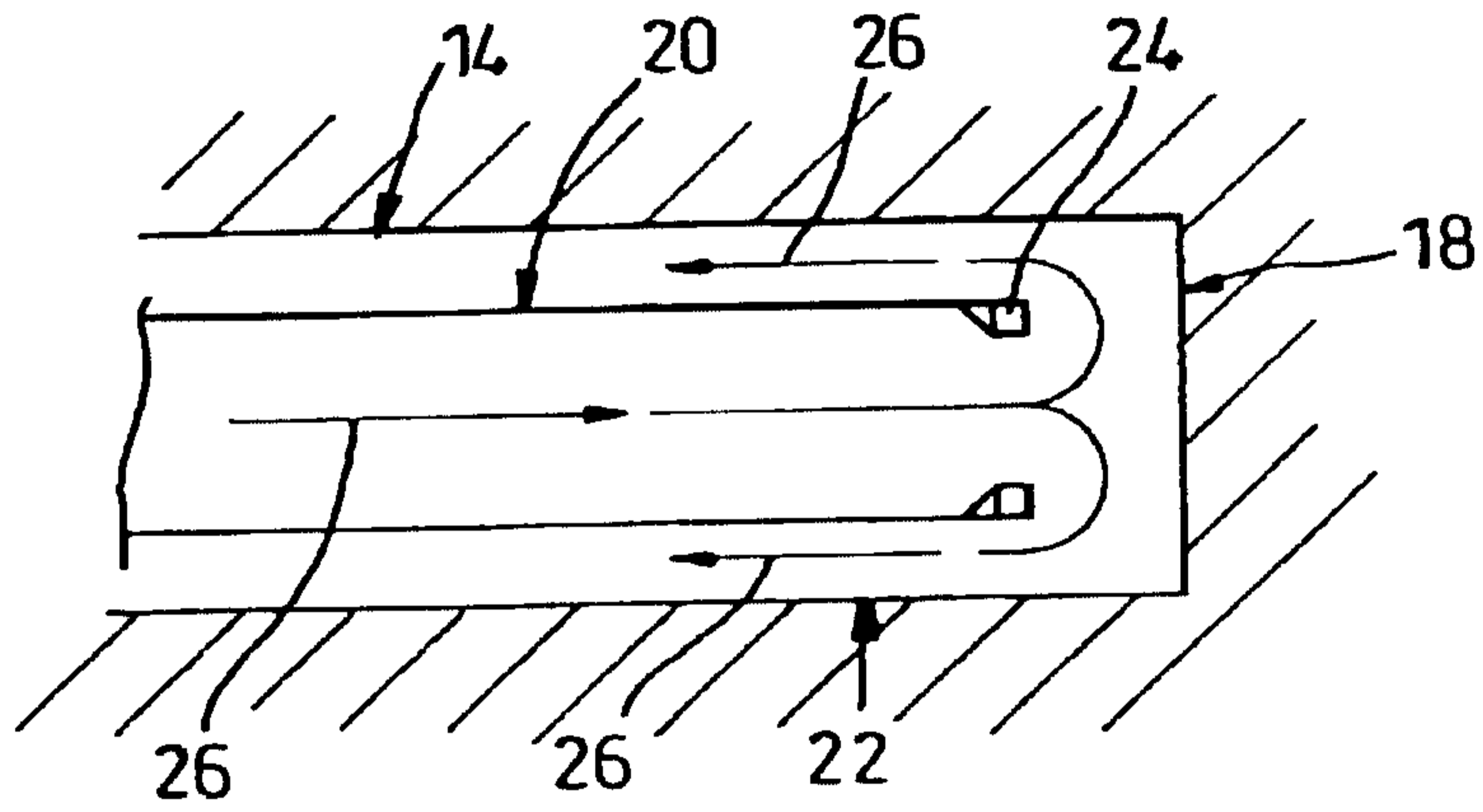

Fig. 2

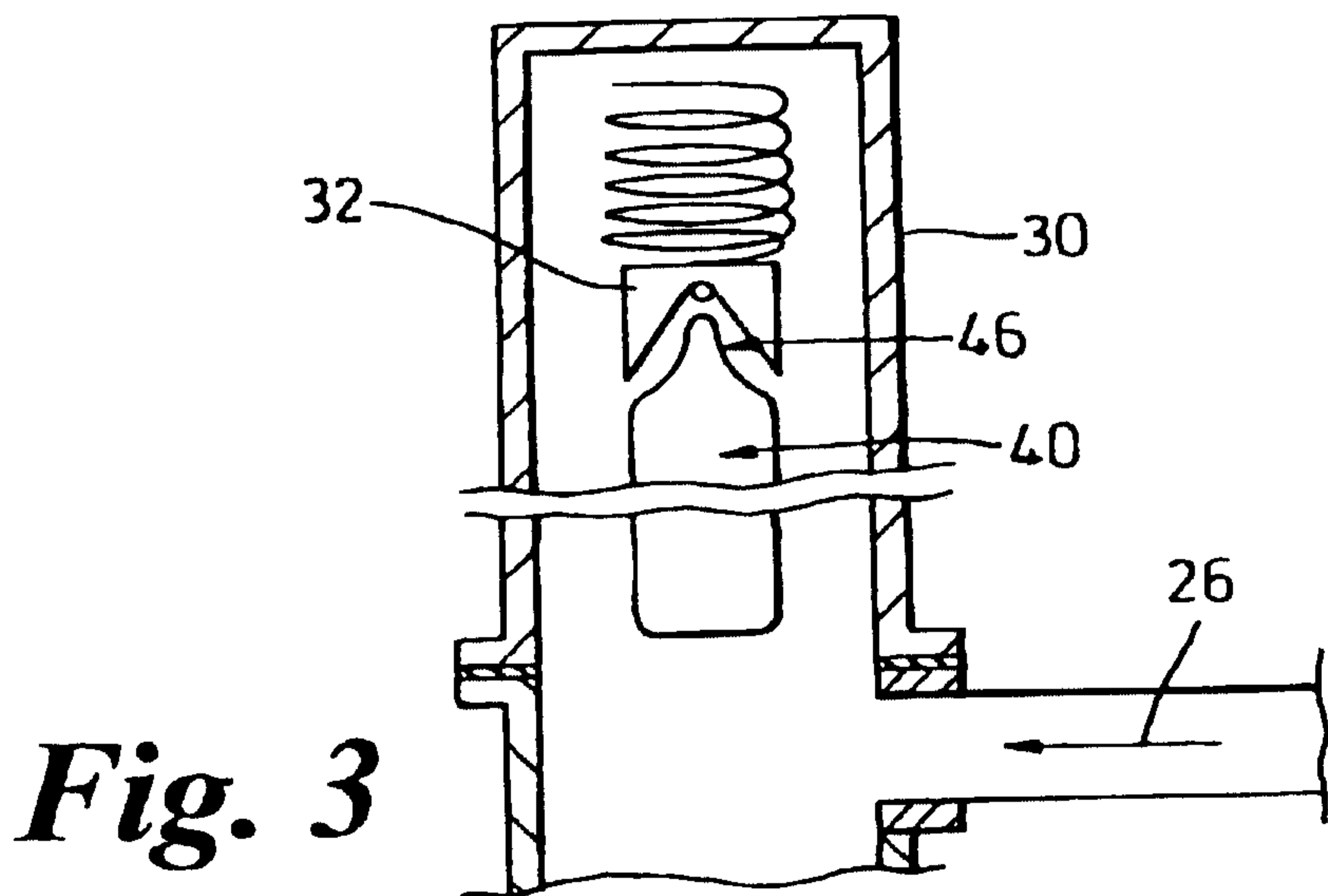

Fig. 3

START:-

WASH PIPE AT 'TD'

INTRODUCE TOOL & PUMP SUB INTO DRILL PIPE & PUMP TOOL TO 'TD'

INCREASE PUMP PRESSURE TO 100lbs. & DIFFERENTIAL VALVE WILL OPEN
FLOW WILL ESTABLISH APPROX. 600lbs. COMPRESSION ON TOOL STRING.

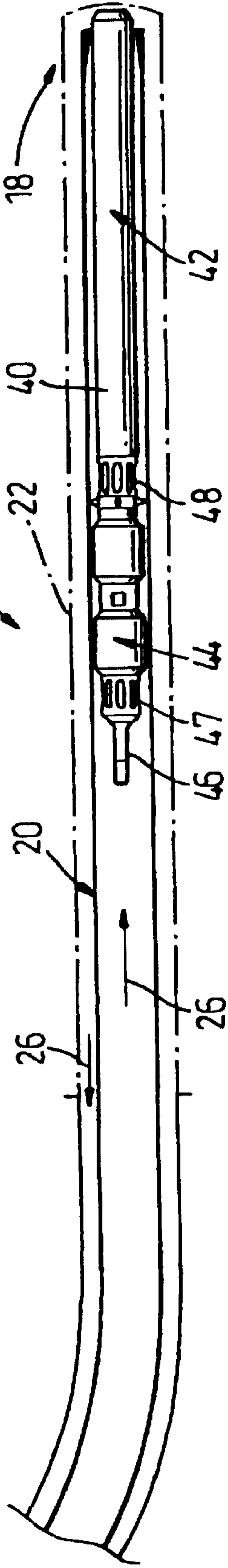

Fig. 4

MAINTAIN PUMP PRESSURE & PULL BACK DRILL PIPE FOR LENGTH OF TOOL
STRING.
THIS WILL LAY TOOL AT 'TD' IN OPEN HOLE.

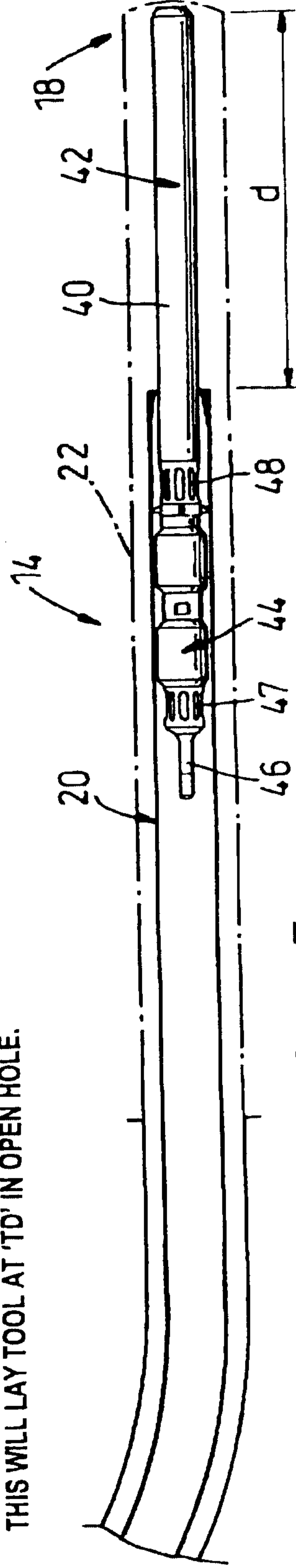
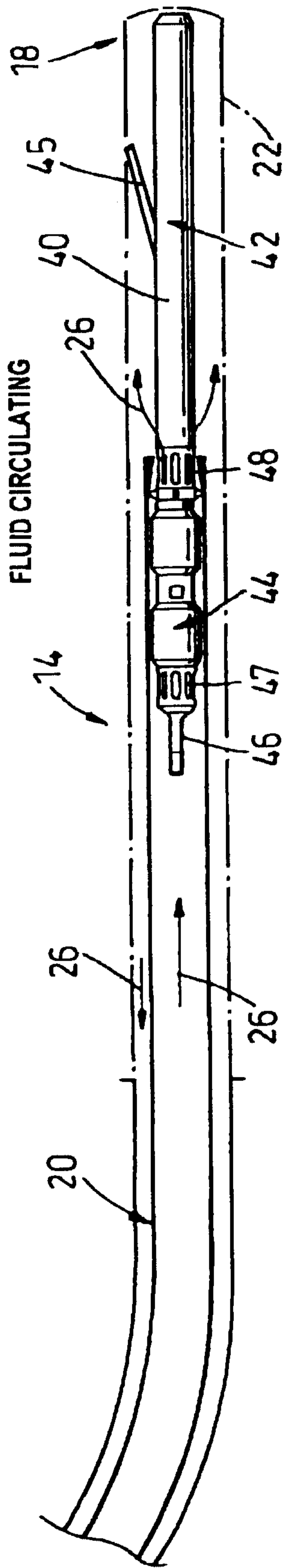

Fig. 5

CALIPER WILL OPEN WHEN WASH PIPE PASSES OVER CCL.

CONTINUE TO PULL DRILL, LOGGING IN PROGRESS.



3/4

Fig. 6

CALIPER ARM CLOSSES AS CCL PASSES CASING SHOE

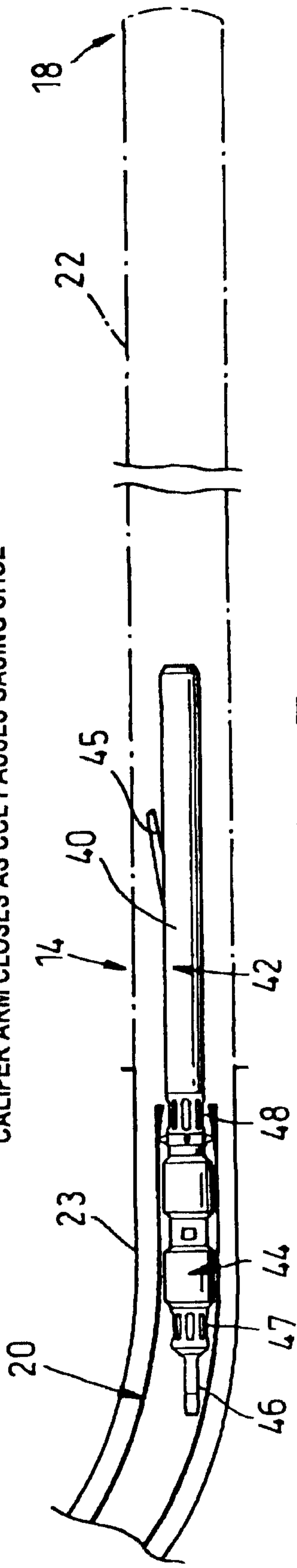

Fig. 7

REVERSE THE MUD FLOW. (70 PSI WILL LIFT TOOL STRING)
 PREPARE TO RECEIVE TOOL AT SURFACE - APPROX 30 MINUTES FROM 10,000 FEET
 DOWN LOAD DATA - 2-3 MINUTES.
 CHECK DATA QUALITY.

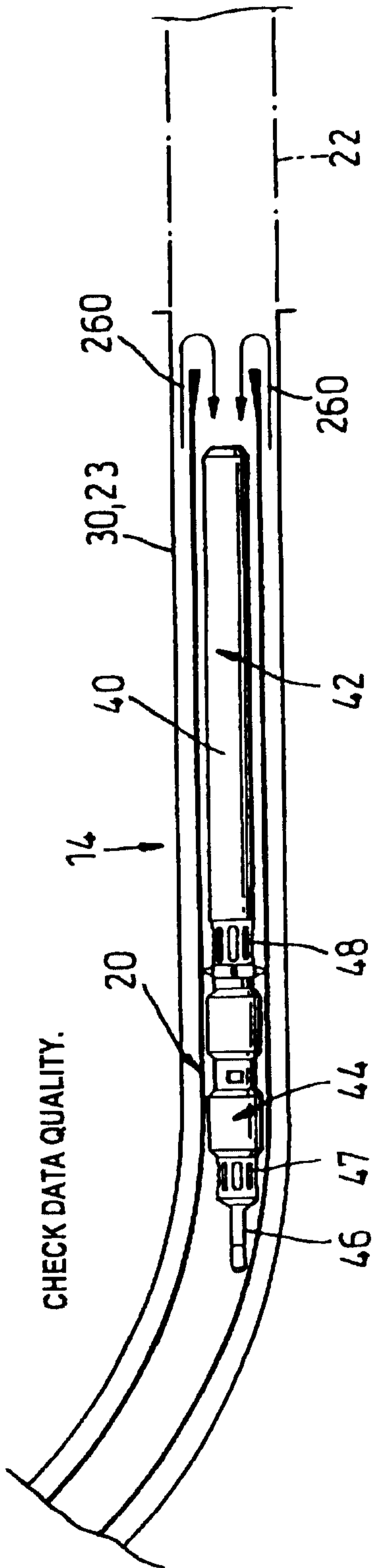

Fig. 8

CONTROL PARAMETERS: IN 2.75" ID DRILL PIPE.
 MUD PRESSURE * 5.9 - TOOL WEIGHT/5.9 = FORCE APPLIED TO SONDE
 FLOW RATE / INTERNAL VOLUME PER FOOT = TOOL SPEED
 VOLUME PUMPED / INTERNAL VOLUME PER FOOT = DISTANCE TRAVELLED (4' / GALLON)