



US00D836510S

(12) **United States Design Patent**
Nakai

(10) **Patent No.:** **US D836,510 S**

(45) **Date of Patent:** **** Dec. 25, 2018**

- (54) **INSTRUMENT PANEL FOR AN AUTOMOBILE**
- (71) Applicant: **HONDA MOTOR CO., LTD.**, Tokyo (JP)
- (72) Inventor: **Yuta Nakai**, Wako (JP)
- (73) Assignee: **HONDA MOTOR CO., LTD.**, Tokyo (JP)
- (**) Term: **15 Years**
- (21) Appl. No.: **29/631,206**
- (22) Filed: **Dec. 28, 2017**
- (30) **Foreign Application Priority Data**

Jun. 30, 2017 (JP) 2017-014198

- (51) **LOC (11) Cl.** **12-16**
- (52) **U.S. Cl.**
USPC **D12/192**
- (58) **Field of Classification Search**
USPC D12/192, 415, 114, 345; D15/17, 28;
D10/46, 98, 102-103, 122-127; D23/324
CPC B60H 1/34
See application file for complete search history.

(56) **References Cited**

U.S. PATENT DOCUMENTS

- D809,443 S * 2/2018 Walker D12/192
- D810,642 S * 2/2018 Nakaya D12/192

- D810,643 S * 2/2018 Takamura D12/192
- D812,536 S * 3/2018 Matsuda D12/192
- D813,127 S * 3/2018 Yamamoto D12/192
- D813,769 S * 3/2018 Yaguchi D12/192
- D817,832 S * 5/2018 Maezono D12/192
- D819,533 S * 6/2018 Choi D12/192
- D824,306 S * 7/2018 Joyce D12/192

* cited by examiner

Primary Examiner — Katrina A Betton

(74) *Attorney, Agent, or Firm* — Westerman, Hattori, Daniels & Adrian, LLP

(57) **CLAIM**

The ornamental design for, an instrument panel for an automobile, as shown and described.

DESCRIPTION

FIG. 1 is a front and right side perspective view of an instrument panel for an automobile, showing our new design;

FIG. 2 is a front and left side perspective view thereof;

FIG. 3 is a front elevation view thereof;

FIG. 4 is a top plan view thereof;

FIG. 5 is a bottom plan view thereof;

FIG. 6 is a right side elevation view thereof; and,

FIG. 7 is a left side elevation view thereof.

The broken lines shown in the drawings illustrate portions of the instrument panel for an automobile that are environmental structures and form no part of the claimed design.

1 Claim, 7 Drawing Sheets

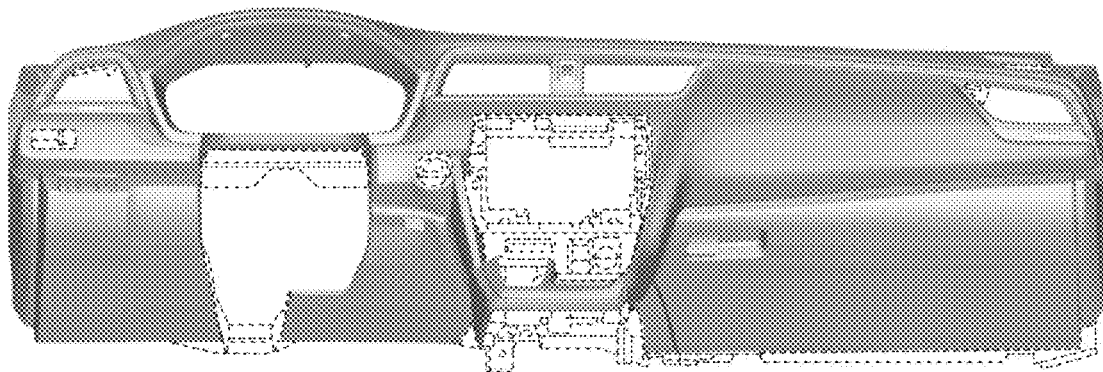

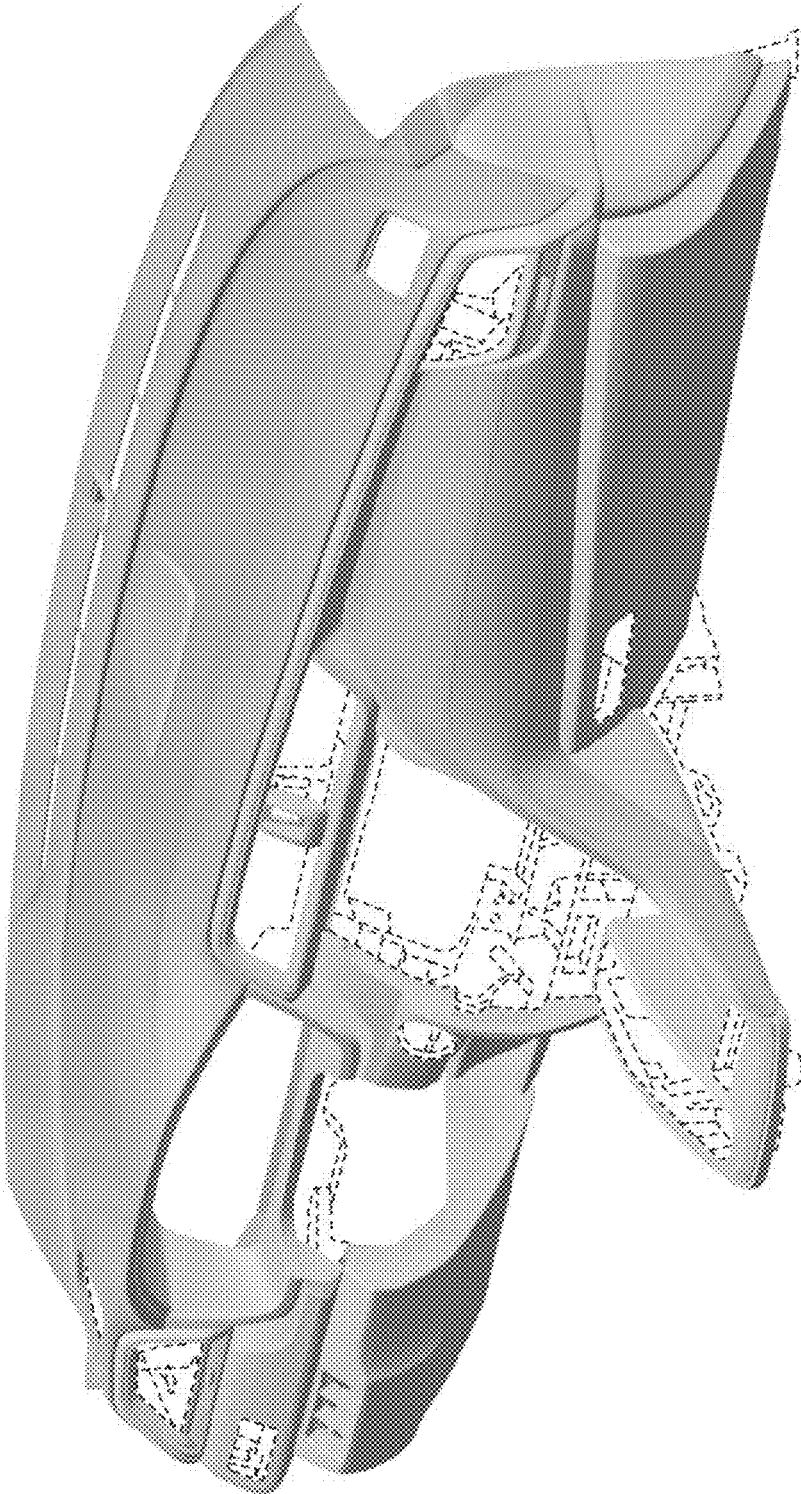

Fig.1

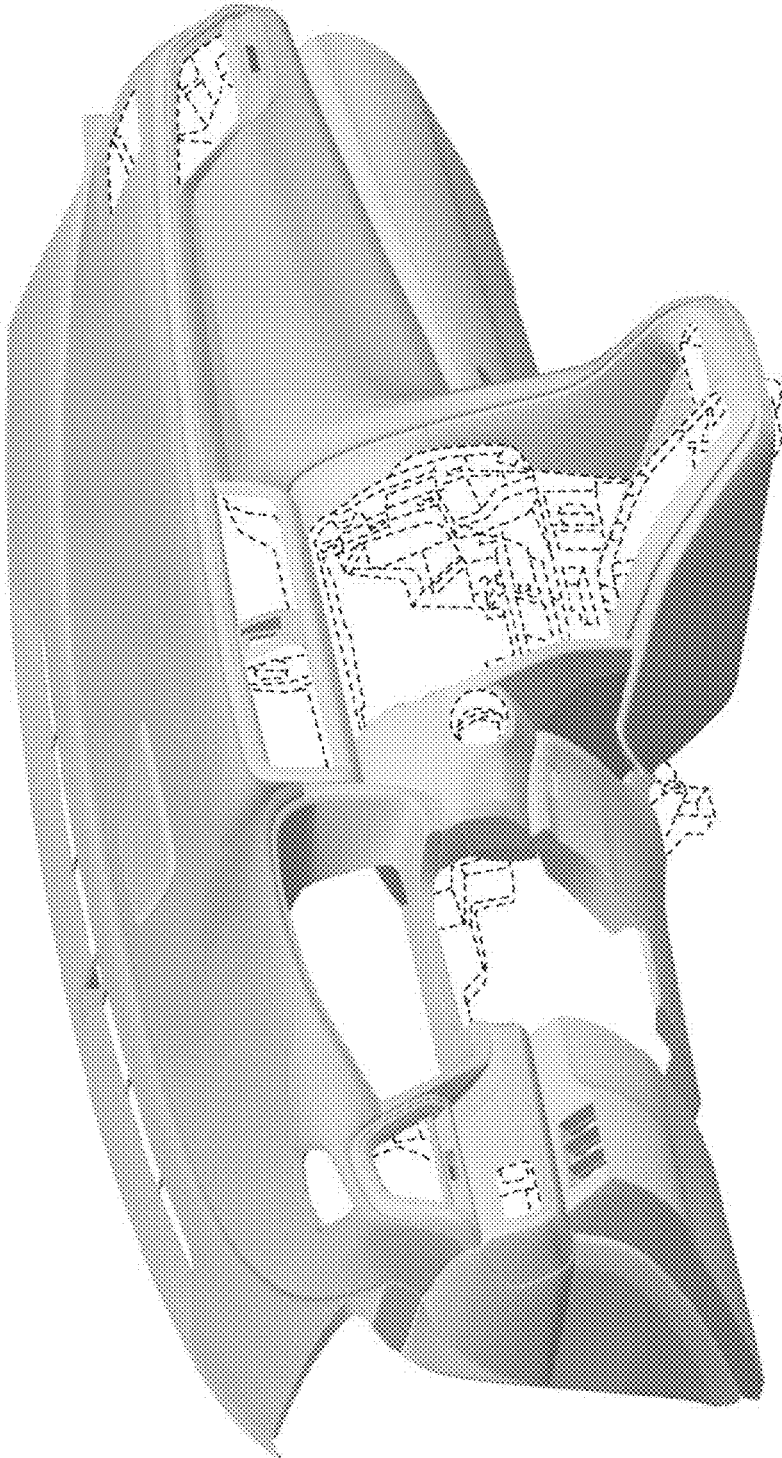

Fig.2

Fig.3

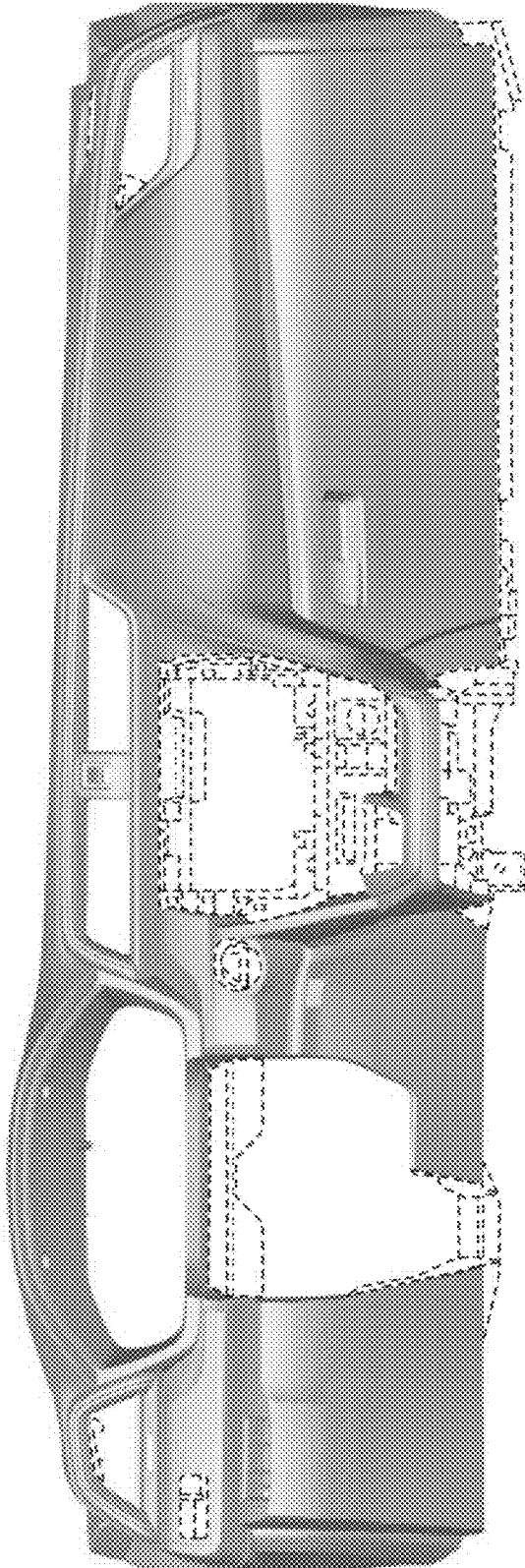
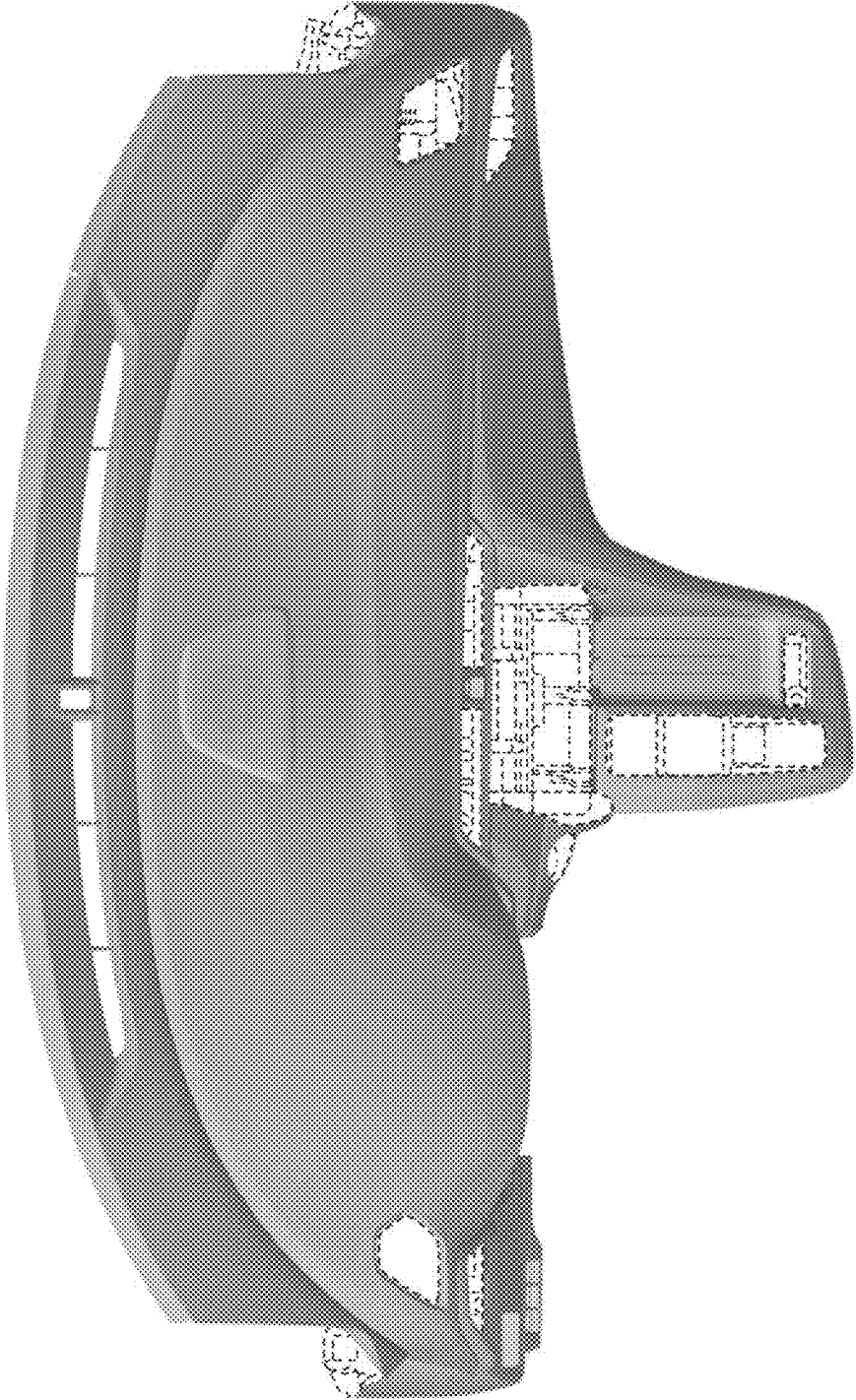

Fig.4



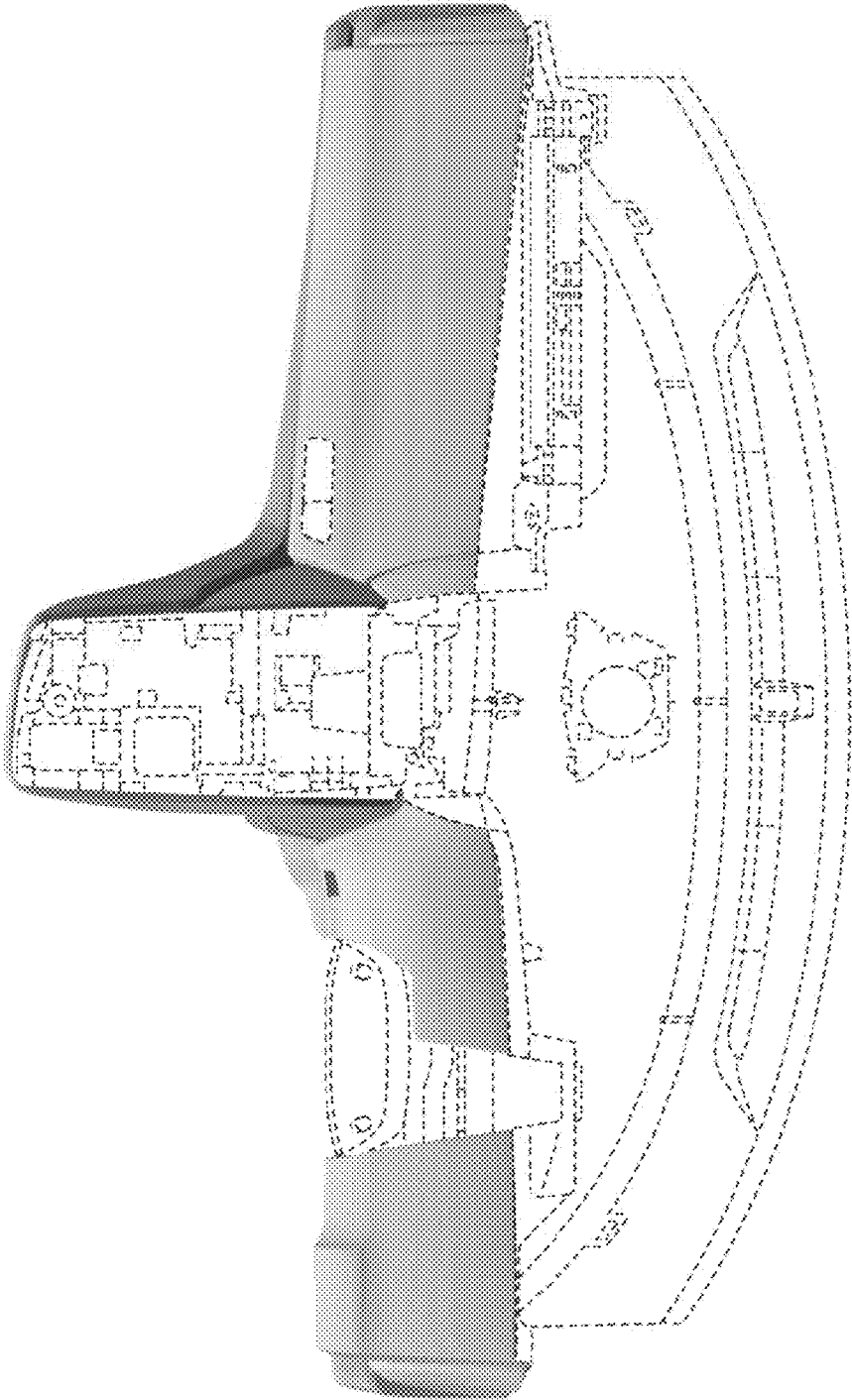

Fig.5

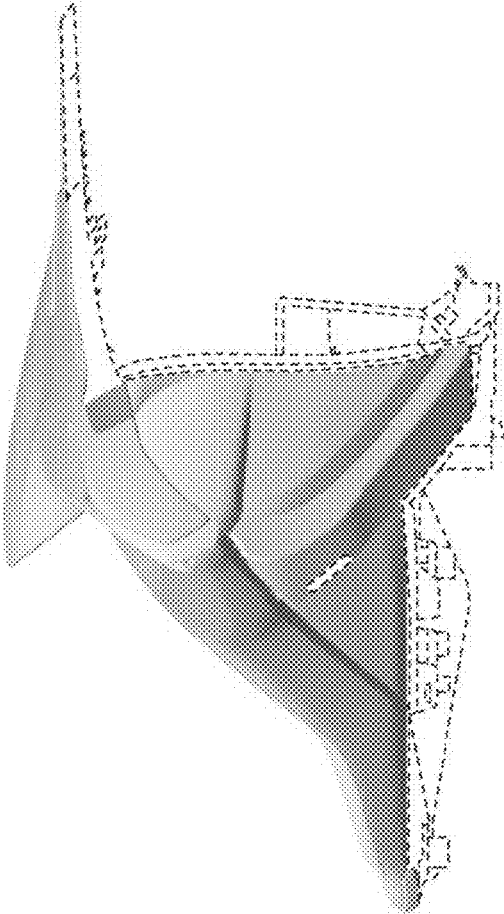

Fig.6

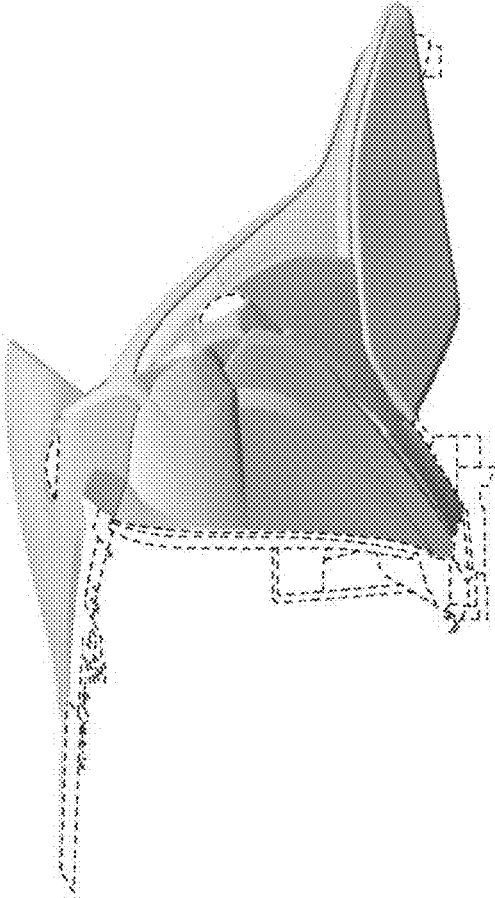

Fig. 7