

(No Model.)

2 Sheets—Sheet 1.

A. M. BOWERS.

LEATHER FINISHING MACHINE.

No. 366,298.

Patented July 12, 1887.

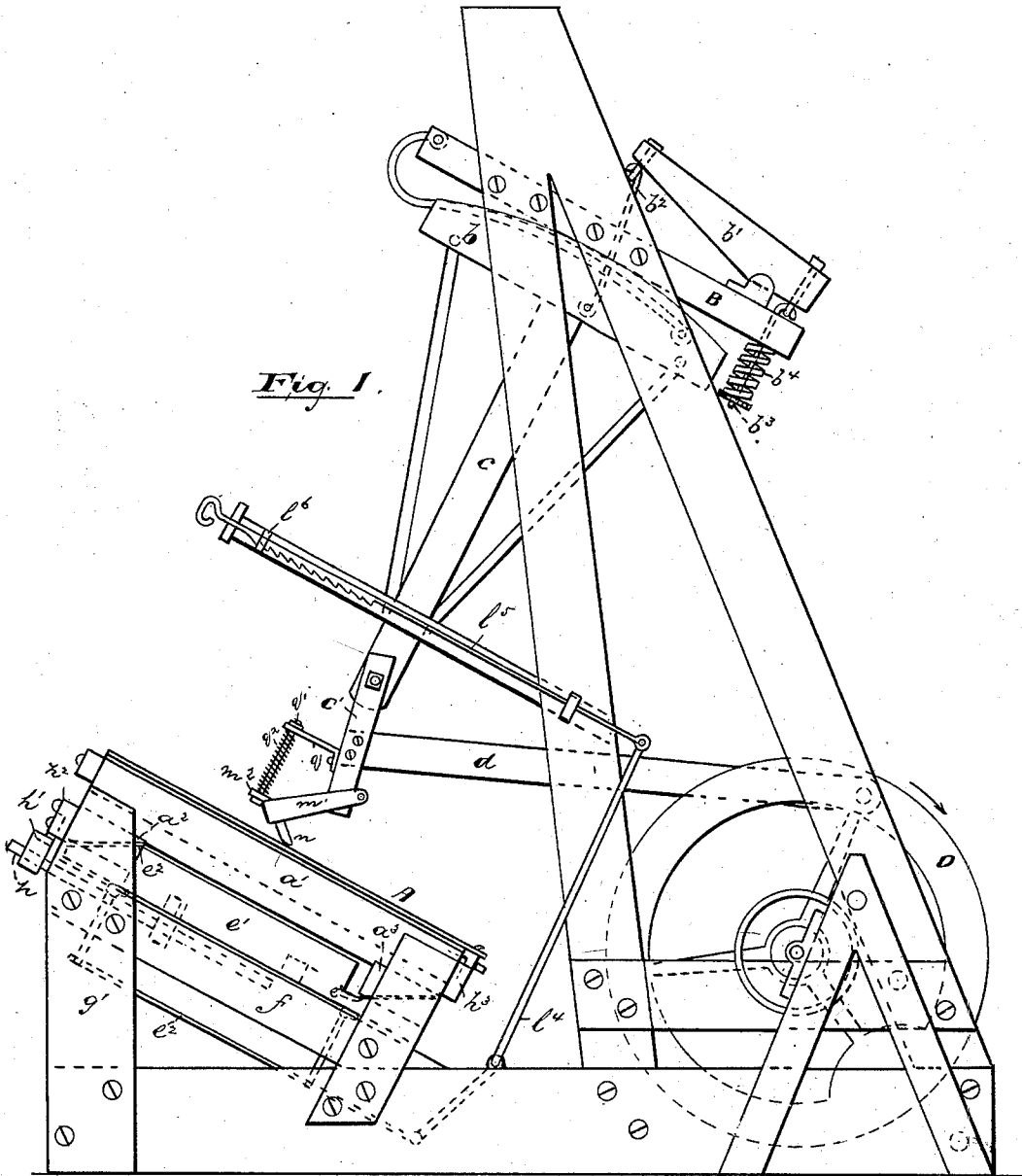

WITNESSES:

INVENTOR

Frank F. Campbell,
C. R. Bennett

Albert M. Bowers,
BY *Drake & Co.,* ATTYS.

(No Model.)

2 Sheets—Sheet 2.

A. M. BOWERS.

LEATHER FINISHING MACHINE.

No. 366,298.

Patented July 12, 1887.

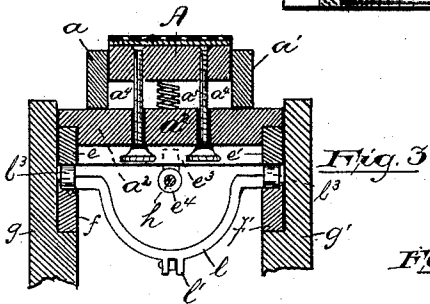
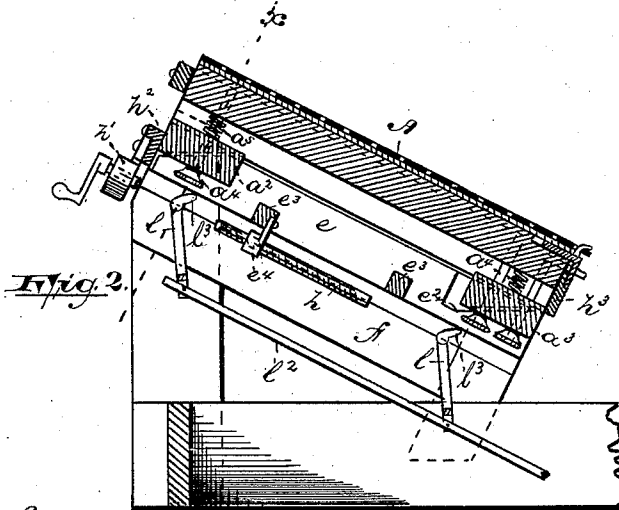

Fig. 4.



Fig. 5.

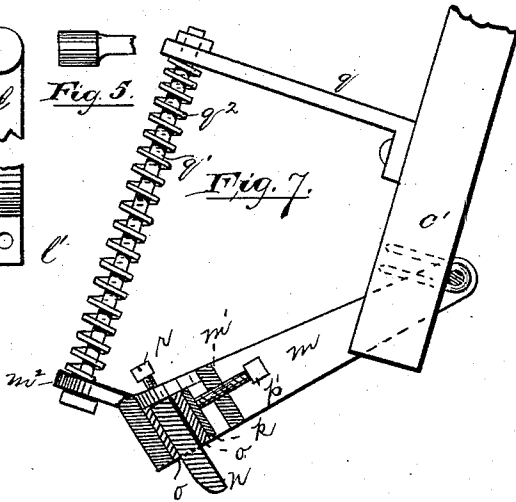

Fig. 7.

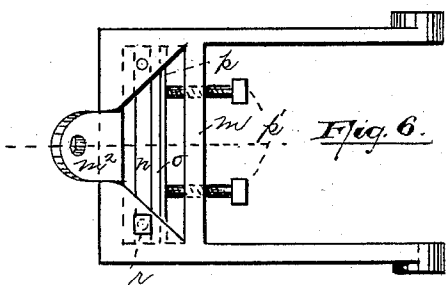

Fig. 6.

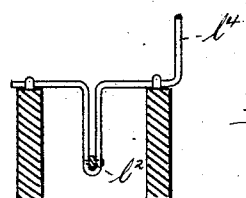

Fig. 8.



Fig. 9.

WITNESSES:

INVENTOR:

Drake F. Campbell.
C. R. Bennett

Albert M. Bowers,

BY *Drake & Co.,* ATTYS.

UNITED STATES PATENT OFFICE.

ALBERT M. BOWERS, OF NEWARK, NEW JERSEY.

LEATHER-FINISHING MACHINE.

SPECIFICATION forming part of Letters Patent No. 366,298, dated July 12, 1887.

Application filed April 5, 1886. Serial No. 197,789. (No model.)

To all whom it may concern:

Be it known that I, ALBERT M. BOWERS, a citizen of the United States, residing at Newark, in the county of Essex and State of New Jersey, have invented certain new and useful Improvements in Leather-Finishing Machines; and I do hereby declare the following to be a full, clear, and exact description of the invention, such as will enable others skilled in the art to which it appertains to make and use the same, reference being had to the accompanying drawings, and to letters of reference marked thereon, which form a part of this specification.

This invention has reference to leather glassing or pebbling machines in general, but more particularly to an improvement in a machine described in Patent No. 339,134, issued to me April 6, 1886, and adapted to be used for a similar purpose.

The objects of the invention are to enable certain portions of the bed of the machine to be removed and other portions substituted therefor, to provide a device whereby the bed may be quickly and easily raised and lowered, and to secure an improved tool or stone holder by means of which a better surface is produced on the leather.

The invention consists in the construction and combination of parts of the machine, substantially as illustrated in the drawings, and described and claimed hereinafter.

In the accompanying two sheets of drawings, in which like letters of reference indicate corresponding parts in each of the views, Figure 1 is a side elevation of a machine illustrating my invention. Fig. 2 is a vertical longitudinal section of the leather-holding bed and supporting-frame, illustrating the construction and operation of the raising and lowering mechanism. Fig. 3 is a transverse section of the said bed, &c., taken on the line x , Fig. 2. Fig. 4 is a side elevation of one of the raising or lifting cams, part of which is broken away; and Fig. 5 is an elevation of the back of the lifting-cam. Fig. 6 is a plan of the improved tool-holder. Fig. 7 is a section of the same attached to the pivoted arm. Fig. 8 is a section of the base-frame pieces and an elevation of a pivoted operating-lever secured thereto; and Fig. 9 is an elevation of the back of the slotted collar.

The machine to which these improvements are applicable and are specially designed consists of a parallelly-arranged leather-holding bed, A, and rocker-tread B, between which oscillates a tool-carrying frame consisting of a rocker, b , held in contact with the tread B by any suitable mechanism, that shown in Fig. 1 of the drawings being a pivoted lever, b^1 , connected at one end to the rocker by a rod, b^2 , the other end of said lever being held in engagement with the tread by a rod, b^3 , and spring b^4 , the remaining portions of the oscillating frame consisting of a beam, c , projecting from the rocker toward the bed A, and a pivoted arm, c^1 , attached to the lower end of said beam.

D is a crank-wheel which is connected with and actuates the arm c^1 by a pitman, d , rigidly attached to the same, the revolution of the said wheel causing an oscillating or reciprocating motion of the beam c and the parts attached thereto, and simultaneously therewith produces a lifting and lowering movement of the pivoted arm c^1 , causing it to approach near to the leather-holding bed during the downward movement thereof, and to lift away from said bed in its upward or return movement. These several portions of the machine and their operations are, however, more fully set forth in the patent hereinbefore referred to, and are thus briefly described to more clearly explain and illustrate the operation and relations of the parts to which this application particularly refers and is designed to cover.

The leather holding or working bed is shown in Figs. 1, 2, and 3, and is constructed and adapted to permit certain portions thereof to be removed and other portions substituted therefor. The said removable portions are the bed A, side guiding-pieces, a^1 , between which the bed moves, and the cross-beams a^2 , which project on each side of the guiding-pieces, as indicated in Fig. 3, and are provided with inclined or beveled recesses in the ends thereof, as dotted on Fig. 2, said parts being held together by bolts a^3 , and the necessary elasticity in the bed A supplied by the springs a^4 , arranged between the said bed and the cross-beams a^2 . The object of thus connecting the above-described parts together is to enable the said parts to be readily removed to permit the substitution of beds of greater or

less width, according to the nature of the work to be done on the machine. Beneath said removable portions are arranged strips $e e'$, provided with inclines e'' , which engage with the inclines on the cross-beams, as indicated in Fig. 1, and connecting said strips are pieces e^3 , to one of which is secured a threaded collar, e^4 . The strips $e e'$ move longitudinally on subtending pieces $f f'$, which are secured to the uprights $g g'$ of the frame of the machine. The longitudinal movement of the strips $e e'$ is caused by a screw, h , turning in a slotted collar, h' , secured to a cross-piece, h^2 , which is in turn bolted to the uprights $g g'$, said screw passing through the threaded collar e^4 , as shown in Fig. 2. By turning said screw the strips are moved longitudinally, and the engagement of the inclined surfaces on said strips and the cross-beams produces a lifting movement of said beams and the working-bed A. Any longitudinal movement of said beams and bed is prevented by the end cross-pieces, $h^2 h^3$, which are secured to the uprights. To supplement this raising and lowering of the bed A, which by means of the above-described mechanism may be exactly and nicely adjusted, and to enable the same to be quickly and readily elevated and depressed, is the purpose of one portion of this invention.

In Figs. 2, 3, 4, and 5 is indicated in detail one form of mechanism which is adapted to accomplish this result. In said figures l indicates a curved rod, provided at its center with bolt-flanges l' , between which a connecting-rod, l^2 , is pivoted, and on each end thereof with cam projections l^3 , which rest in or on the subtending pieces $f f'$, and engage with the under side of the strips $e e'$, as shown in Fig. 2.

On Fig. 1 is shown in dotted lines the position of the lifting devices when in their normal or lowest position, while Fig. 2 indicates the relation of the parts when said lifting devices or cams are operated to lift the superincumbent parts. To operate said cams, a lever, l^4 , pivoted to the frame of the machine at any suitable point, may be used, one end of which is pivotally attached to the connecting-rod and the other to a rod, l^5 , having teeth engaging with a stop, l^6 . By pulling said rod l^5 one or more teeth, as may be desirable, the cams are caused to engage the strips $e e'$ and lift the same, as shown in Fig. 2. From the construction of this lifting mechanism it is evident it may be operated very quickly and easily. A simple pull upon the rod l^5 will cause the elevation of the bed and the connected parts, the height to which the bed, &c., is raised depending upon the number of teeth or the distance of the movement of the rod l^5 . It will be noticed that both of the devices for raising the bed—viz, the lifting-cams and the inclined sections—and the actuating-screw are arranged independently one of the other, the lifting-cams being beneath the bed and both of the inclined sections, and elevating them simultaneously.

In Figs. 1, 6, and 7 is illustrated an improved tool or stone holder consisting of a frame having arms m , pivotally attached to the arm e' and provided with a partition, m' , and a projecting arm, m^2 , having a bolt-perforation therein. In the space between the partition and the end of the frame is arranged the stone n , held between leather pieces o , and against the leather next to the partition is placed a steel plate, p , which receives the end of the set-screws p' , that hold the several parts together. Above the pivoted tool-holding frame is arranged an arm, q , projecting from the pivoted arm e' , to which it is secured; and extending through said arm q and the projecting piece m^2 on the tool-frame is a bolt, q' , around which is arranged a spiral spring, q^2 , as indicated in Figs. 1 and 7. By reference to said figures it will be seen that said tool-holding frame is arranged on the back of the pivoted arm e' , or on that side thereof away from the crank-wheel, so that as the oscillating beam moves toward the crank and the pivoted arm e' approaches near to the bed A the tool is caused to engage with said bed during the forward movement of the beam, being drawn after the arm e' , as shown in Fig. 1.

By virtue of the elasticity of the spring q^2 , which presses the tool down upon the bed, or the leather placed thereon, the tool readily accommodates itself to any inequalities in the leather, and also to thick or thin hides. Moreover, the pressure upon the leather is identical with that applied by the workman when the hides are treated by hand, the tool being inclined at the same angle as when held in the hands.

By means of the set-screws r the tool as it becomes worn may be adjusted.

Having thus described my invention, I wish to claim the following:

1. In a leather-finishing machine, the combination, with the fixed portions of the frame thereof provided with strips having inclined surfaces thereon, of a spring-supported leather-holding bed, A, side guiding-pieces, $a a'$, arranged on opposite sides of said bed, cross-pieces arranged transversely beneath guiding-pieces and provided with inclined surfaces thereon, which engage with the inclined surfaces on the strips forming part of the fixed or permanent portions of the frame, said bed, guiding-pieces, and cross-pieces being bolted together, and suitable cams adapted to lift said parts clear of the permanent portions of the frame, substantially as set forth.

2. In a leather-finishing machine, the combination of an oscillating beam, an arm rigidly secured to and projecting from said beam, a tool-carrying frame pivotally secured to said beam and projecting backward therefrom, substantially as described, said frame being provided with an arm, m^2 , and a partition, m' , having set-screws therein, and a spiral spring and supporting rod or bolt, q' , interposed between the rigid arm on the oscillating beam

and the projecting arm m^2 on the pivoted frame, substantially as and for the purpose set forth.

3. In a leather-finishing machine, the combination, with the leather-holding bed and the frame of the machine, of a rod, l , having at its extremities cam projections l^2 , a connecting-rod, and an operating-lever, all said parts being arranged and combined substantially as and for the purposes set forth.

4. In a leather-finishing machine, the combination, with a leather-holding bed provided with frame-pieces having co-operating inclined or beveled surfaces and means for causing the operative engagement of said inclines, of lifting-cams pivotally arranged beneath the lower of said frame-pieces having the inclined surfaces thereon, and engaging with the under side thereof, and means, substantially as described, for operating said cams, substantially as and for the purposes set forth.

5. In a leather-finishing machine, the combination, with the leather-holding bed A, side guiding-pieces, $a a'$, cross-pieces $a^2 a^3$, provided with inclined surfaces thereon, strips $e e'$, also provided with inclines which engage with the inclines on the pieces $a^2 a^3$, and a screw, h , arranged and operating substantially for the purpose set forth, of lifting-cams l^2 , pivotally arranged beneath said strips $e e'$ and connected by a rod, l , a connecting-rod, l^2 , and operating-levers pivoted to said connecting-rod, all said parts being arranged and operating for the purposes set forth.

In testimony that I claim the foregoing I have hereunto set my hand this 3d day of April, 1886.

ALBERT M. BOWERS.

Witnesses:

FREDK. F. CAMPBELL,
CHARLES H. PELL.