

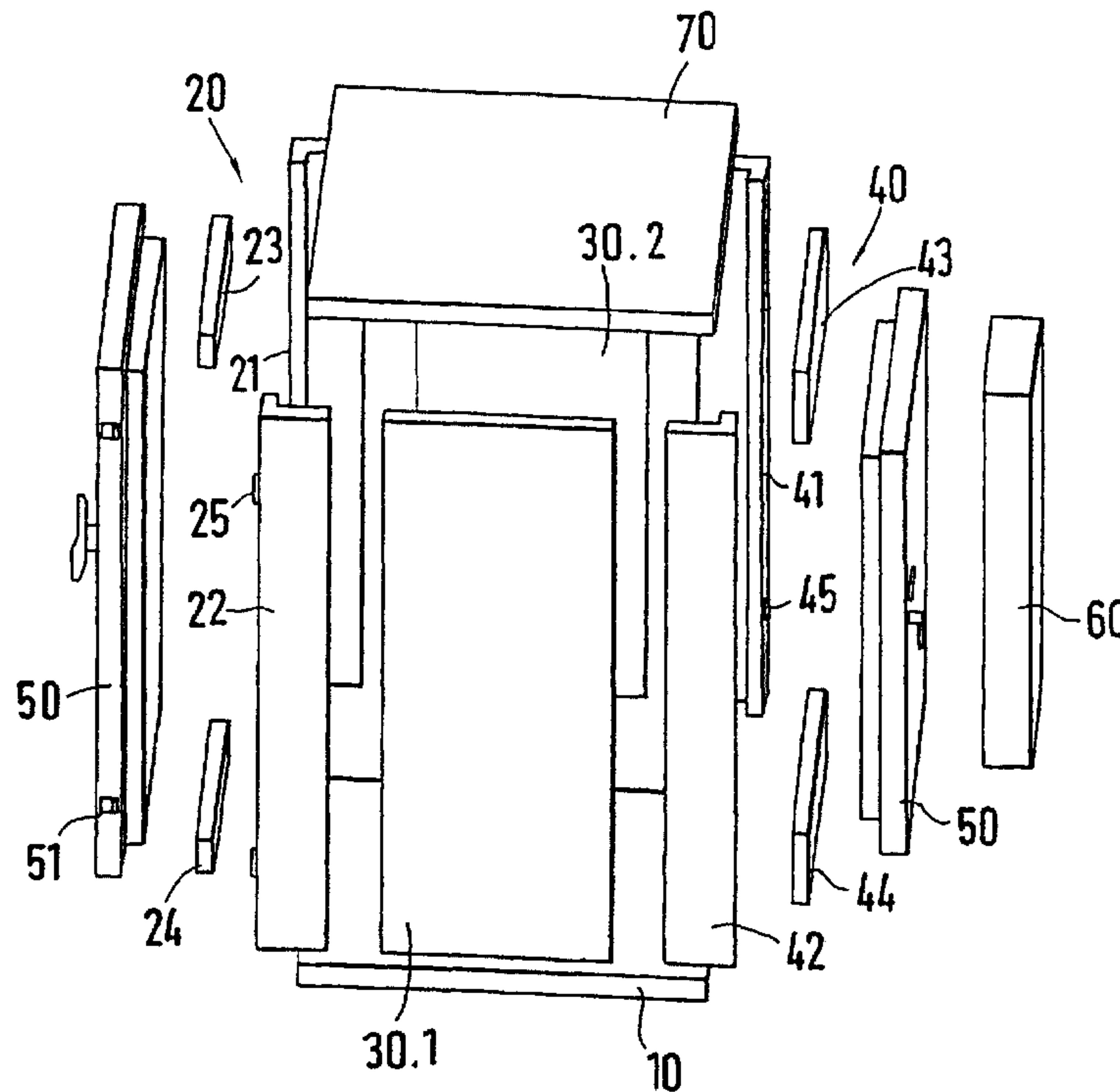

(86) Date de dépôt PCT/PCT Filing Date: 1999/05/21  
 (87) Date publication PCT/PCT Publication Date: 2000/06/15  
 (85) Entrée phase nationale/National Entry: 2001/06/01  
 (86) N° demande PCT/PCT Application No.: EP 99/03510  
 (87) N° publication PCT/PCT Publication No.: WO 00/34613  
 (30) Priorité/Priority: 1998/12/04 (198 55 931.3) DE

(51) Cl.Int.<sup>7</sup>/Int.Cl.<sup>7</sup> E05G 1/024, E04H 1/12, G06F 1/18  
 (71) Demandeur/Applicant:  
 OTTO LAMPERTZ GMBH & CO. KG., DE  
 (72) Inventeurs/Inventors:  
 WELLER, TORSTEN, DE;  
 FRASE, HANS-JURGEN, DE  
 (74) Agent: SWABEY OGILVY RENAULT

(54) Titre : PROCEDE DE MONTAGE D'UN COFFRET DE SECURITE ET DE REVETEMENT D'UN MONTAGE EN BAIE  
 EQUIPE ET RACCORDE; KIT DESTINE A LA MISE EN OEUVRE DE CE PROCEDE  
 (54) Title: METHOD FOR ASSEMBLING A STRONGBOX AND FOR COATING AN EQUIPPED AND CONNECTED  
 FRAMEWORK AND KIT FOR CARRYING OUT SAID METHOD



(57) Abrégé/Abstract:

The invention relates to a method for assembling a strongbox and for subsequently coating an equipped and connected framework with coating elements and at least one door. The coating is provided in the form of a bottom element (10) and frame elements (20, 40) at the front and/or rear end of the framework and lateral elements (30.1, 30.2) and an upper element (70). Said coating accommodates the framework depending on the kind of protection required. According to the inventive method, the elements are interlinked by means of simple joining elements (80, 90). It is also possible to juxtapose several partial boxes to give an aggregate box.

## ABSTRACT

The invention relates to a method for assembling a strongbox and for subsequently coating an equipped and connected framework with coating elements and at least one door. The coating is provided in the form of a bottom element (10) and frame elements (20, 40) at the front and/or rear end of the framework and lateral elements (30.1, 30.2) and an upper element (70). Said coating accommodates the framework depending on the kind of protection required. According to the inventive method, the elements are interlinked by means of simple joining elements (80, 90). It is also possible to juxtapose several partial boxes to give an aggregate box.

Method for Assembling a Strongbox and for Coating an  
Equipped and Connected Framework and Kit for Carrying Out said Method

5 The invention relates to a method for constructing a secure cabinet, and for subsequently paneling an equipped and connected rack structure with paneling elements and at least one door, as well as to a kit for executing the method.

10 It quite often occurs that, because of changing operating conditions or uses, already assembled and ready-to-operate rack structures need to be later protected to a greater or lesser extent. Some examples of this are protection against dust, splashing water, noise and fire, for example, which require the subsequent paneling of the rack structure.

15 It is the object of the invention to provide a method for constructing a secure cabinet, and in particular a subsequent paneling of a ready-to-operate rack structure, which can be performed with simple means without interfering with the rack structure.

20 This object is attained in accordance with the invention in that the rack structure is raised by at least the thickness of a bottom element, that the rack structure is placed and positioned on the bottom element placed underneath it, that a front grooved element with connecting elements for a door element is placed on the bottom element in the area of the front of the rack element and is connected therewith, that the front grooved element is connected with side elements placed on the bottom element, that a rear grooved element or a rear wall element is placed on the bottom element in the area of the back of  
25 the rack structure and is connected with the two side elements, and that a top element is placed on the grooved elements, the side elements and possibly the rear wall element and is connected with the grooved elements and/or with the side elements.

By means of a lifting element, the rack structure can be raised to the height required for sliding the bottom element underneath it without releasing the connector cables. Once the bottom element has been slid underneath it, the rack element is put down and positioned in such a way that it projects on all sides from the rack element sufficiently far so that the elements provided for paneling can be placed on the bottom element and connected with it, if desired.

If no rack element is provided, the secure cabinet can also be constructed without resorting to the first two steps in order to arrange the built-ins in the cabinet later.

A front and a rear grooved element are used if it is intended for the front and the rear of the paneled rack structure to be accessible. If access is required only from the front, the back is paneled with a rear wall element and/or is provided with an air conditioner. The connection of the elements with each other is performed at predetermined places, which are aligned with each other, of the horizontally and/or vertically abutting front faces of the elements, wherein the number of the connection points between two elements can be two or more in order to achieve sufficient support.

It is also conceivable to line up several grooved elements on the front and rear wall elements in order to construct a lined-up cabinet arrangement, wherein the intervening side walls are omitted, and several bottom elements or one common bottom element can be employed.

In accordance with a preferred embodiment it is provided that the front and the rear grooved elements are put together from vertical and horizontal frame legs in the form of a frame. In this case it is moreover possible for reducing the required elements that the front and rear grooved elements are identically embodied.

An embodiment is also used for the same purpose which is distinguished in that the bottom element and the top element are identically embodied.

5 A simple assembly of the paneling, which can be quickly performed, is achieved in that turning bar closures, known per se, are used for connecting the elements, whose closure elements, which are matched to each other, are installed in the elements at the abutting faces of connecting points aligned with each other. Such hook closures are commercially available, wherein the two closure elements can be installed in the abutting front faces of  
10 the elements. The hook can be rotatably seated in the one closure element and can be inserted into the other sleeve-like closure element. After having been inserted, the hook is turned on top of a clamping bolt and is appropriately clamped in the course of an additional eccentric displacement, so that the elements connected with each other are pulled toward each other under tension.  
15 To this end, the elements need only have one access opening to the rotary bearing of the hook, so that the latter can be turned in the associated closure part.

So that uniform connecting elements can be used at all connecting points, a further embodiment provides that the vertical frame legs of the  
20 grooved elements are designed to be L-shaped in cross section and are provided with connecting faces for the vertical side elements.

In accordance with a preferred embodiment the structure of the elements is designed in such a way that the elements are embodied to be double-walled and are filled with insulating material.

25 In this connection it is possible to advantageously provide an insulating material having sound protection and/or fire protection properties, which is enclosed in sheet metal walls.

In order to seal the joints between the elements in a fire-proof manner, an embodiment provides that the joints between the elements are

sealed by means of highly temperature-resistant sealing elements, which expand in case of fire.

The attachment of the doors can easily be solved in that the front and the rear grooved elements are closed off by means of door elements, wherein the vertical frame legs of the grooved elements and the door elements are provided with hinge and closure elements at points matching each other.

A kit for executing the method in accordance with the invention consists of:

- a) panel-shaped structural elements, side elements and top elements,
- b) frame-like front grooved elements, and
- c) frame-like rear grooved elements or panel-shaped rear wall elements,

all of which are connected by means of complementary connecting elements at the abutting horizontal and/or vertical front faces at connecting points, which are aligned with each other, and can be connected in this way.

To reduce the number of different required elements, the procedure is advantageously such, that the bottom elements and the top elements, as well as the front and rear grooved elements, are each identically embodied.

For compartmentizing the secure cabinet, while simply constructed, it is provided that horizontal frame legs are provided at least partially with fire-proof and gas-tight cable bulkhead elements.

The interior can be easily enlarged in that several grooved elements, or rear wall elements, are sealingly connected with each other, while omitting the side elements.

The invention will be explained in greater detail by means of an exemplary embodiment represented in the drawings. Shown are in:

Fig. 1, a perspective exploded representation of the elements required for paneling a ready-to-operate connected rack structure,

Fig. 2, a connecting point between two elements in an enlarged partial sectional view,

5 Fig. 3, a commercially available turning bar closure in a perspective plan view, and

Fig. 4, a partially paneled rack structure for explaining the method.

Fig. 1 shows the elements for the structure of a secure cabinet, and in particular for paneling closed or closeable on all sides, of a ready-to-operate rack structure. The kit comprises bottom elements 10 and top elements 70, which are preferably embodied in a panel shape and identical. The front is closed by means of front grooved elements 20, which are put together from vertical frame legs 21 and 22 and horizontal frame legs 23 and 24. The vertical frame legs 23 and 24 are L-shaped in cross section, so that narrow front faces are provided on both sides for a connection with adjoining elements. This has the advantage that it is possible to install uniform closure elements in these front faces at all connecting points. A simple lining-up of several secure cabinets is possible when omitting intermediate walls.

20 If the back is also closed by means of a door element 50, a rear grooved element 40 is used, which is composed of vertical frame legs 41 and 42 and horizontal frame legs 43 and 44 and can receive a door element 50 or a rear wall element 60, which advantageously can be an air conditioner. The rear wall element 60 can also be directly connected with the side elements 30.1 and 30.2 without a rear grooved element 40. The same as the vertical front faces of the door elements 50, the vertical front faces of the vertical frame legs 21 and 22, or 41 and 42, of the front or rear grooved elements 20 and 40 can be provided with matched hinge and closure elements, as indicated by reference numerals 25, 45 and 51. Since these elements are known per se for door

fastening, they will not be discussed in greater detail within the scope of the present invention, since sufficient structural embodiments are available for this.

5 A so-called turning bar closure is preferably used for connecting the elements with each other, as shown in Fig. 2. The sectional view shows a connecting point between the vertical frame leg 21 and the horizontal frame leg  
10 23 of the front grooved element 20. Here, the closure part 80 with a rotatably seated hook 81 has been installed in the vertical front face of the frame leg 21, while the matching closure part 90 with the clamping bolt 91 has been installed in the vertical front face of the frame leg 23. As Fig. 3 shows, the hook 81  
15 protruding from the frame leg 21 can be inserted into the sleeve-like closure part 90 and, by rotating it, can be brought into engagement with the clamping bolt 91. If, in the final phase of the rotation the hook 81 is drawn into the closure part 80, which can be effected by means of an eccentric, the frame legs 21 and 23 are pulled against each other and clamped.

15 Fig. 2 also makes the double-walled construction of the elements visible. As an example, the frame legs 21 and 23 are enclosed by sheet metal walls 26 and 27, the same as all elements, and are filled with insulating material 28 and 29. The selection of the insulating material is determined by the sound protection, heat protection, fire protection, etc. demanded. The joint between  
20 the elements connected with each other in this way is sealed by means of a sealing element 100, which must be highly temperature-resistant when used as fire protection.

It is clear that the elements can be connected with each other above each other along their vertical and/or horizontal front faces, wherein two  
25 or more connecting points are selected per element. The connecting elements are each formed by the two closure elements 80 and 90 and are aligned with each other.

The method in accordance with the invention will now be explained in greater detail with the aid of Fig. 4 wherein, for the sake of

simplicity, only the frame structure of the rack structure is represented. Equipping with sub-assemblies can be arbitrarily performed, and the connector cables are preferably inserted through the side walls of the rack structure and connected. Tested, fire-proof, water- and gas-tight cable bulkhead systems are employed here.

At the start of the method, the rack structure 200 is raised by means of a lifting device until a floor element 10 can be slid underneath it. The rack structure 200 is then placed on the floor element 10 slid underneath it and in the process is positioned in such a way that the bottom element 10 protrudes for the same amount on all sides past the exterior of the rack structure 200.

Thereafter the front grooved element 20, put together from the frame legs 21, 22, 23 and 24, is placed on the projecting portion of the bottom element 10 in the area of the front of the rack structure 200 and is connected with the bottom element 10. Preferably two turning bar closures in accordance with Fig. 3 have been installed here in the area of the exterior of the lower horizontal frame leg 24 and the facing side of the bottom element 10 wherein, for example, the closure element 90 has been inserted in the bottom element 10, and closure elements 80 have been installed in the frame leg 24. The bar shafts 82 are preferably embodied as tool receivers, which are accessible via access openings 83 in the frame leg 24.

Once the front grooved element 20 has been connected with the bottom element 10, the panel-shaped side elements 30.1 and 30.2 are placed on the bottom element 10 and connected with the front faces of the free legs of the L-shaped vertical frame legs 21 and 22 of the front grooved element 20 and/or the bottom unit 10. It is possible here to employ respectively two or more turning bar closures per joint. As indicated in Fig. 2, the joints are sealed by means of sealing elements 100, which are composed in accordance with the desired properties.

The elements themselves are embodied such that, together with the sealing elements 100, they provide a desired protection - heat protection, sound protection, fire protection, protection against splashing water, etc. - for the rack structure 200.

5           The back of the rack element 200 can be covered with a rear grooved element 40, which is put together from the frame legs 41, 42, 43 and 44, wherein the connections between the frame legs can also be provided by means of turning bar closures which are installed in the area of the joints and are sealed by means of a seal element 100.

10           As Fig. 4 shows, the free vertical front faces of the side elements 30.1 and 30.2 are provided with closure elements 80, whose bars 81 can be inserted into closure elements 90 which, with their clamping bolts 91, have been installed in the vertical frame legs 41 and 42 of the rear grooved element 40. As already mentioned, a door element 50 can also be hinged on the rear  
15           grooved element. However, a rear wall element 60 can also be inserted into the rear grooved element 40 and connected with the rear grooved element 40. A rear wall element 60 of an appropriate size can also be directly connected with the lateral elements 30.1 and 30.2. It is possible here to provide all horizontal and vertical joints with two or more turning bar closures.

20           At the end, a top element 70 is placed on the grooved elements 20 and 40 and the side elements 30.1 and 30.2 and they are connected with each other and with it in the area of its joint by means of turning bar closures. In this case the access openings 83 to the rotating shafts 82 of the bars 81 can be accessible from the outside or the inside of the completed paneling.

25           It is advantageous if the bottom element 10 and the top element 70 are embodied to be identical. The same also applies to the front grooved element 20 and the rear grooved element 40, and the side elements 30.1 and 30.2 are of course also identically embodied. In this way the number of different elements required is reduced. Uniform connecting elements, for

example turning bar closures known per se, are employed at all connecting points. Other closures are also conceivable.

5 A cutout, through which the connector cables are conducted to the rack structure 200, can be provided in the rear grooved element 40 or the rear wall element 60 in the area of the rear of the rack structure 200. The connector cables in the cutout can be sealed by means of a cable guide, which can be subsequently inserted.

## Claims

1. A secure cabinet, having a bottom element (10), two side elements (30.1, 30.2), a rear wall element (60), a top element (70) and at least one door element (50), which are provided with seals and complementary connecting elements (80, 90) at connecting points which are aligned with each other, for assembly and disassembly by the user,

characterized in that

all elements (10, 20, 30.1, 30.2, 40, 60, 70) are embodied to be double-walled and are filled with an insulating material (28, 29) as a noise protection and/or fire protection, which is enclosed in sheet metal walls (26, 27), and

the joints between the elements (10, 30.1, 30.2, 60, 70) are sealed by means of high temperature-resistant sealing elements (100).

15

2. The secure cabinet in accordance with claim 1, characterized in that

the connecting elements (80, 90) are embodied as turning bar closures (80, 90) and are installed in the abutting faces of the side elements (30.1, 30.2), of the rear wall element (60), the bottom element (10) and/or the top element (70).

20

3. The secure cabinet in accordance with claim 1 or 2, characterized in that

the bottom element (10) and the top element (70) are identically embodied.

25

4. The secure cabinet in accordance with one of claims 1 to 3, characterized in that

a second door element (50) is used in place of the rear wall element (70).

5           5.       The secure cabinet in accordance with one of claims 1 to 4, characterized in that

frame-like front and rear grooved elements (20, 40) are placed on the bottom element (10), as well as connected with the side elements (30.1, 30.2) and/or the bottom element (10).

10           6.       The secure cabinet in accordance claim 5, characterized in that

the front and rear grooved elements (20, 40) are assembled in a frame-like manner from vertical and horizontal frame legs (21, 22; 41, 42 and 23, 24; 43, 44) and are identically designed.

15           7.       The secure cabinet in accordance with claim 5 or 6, characterized in that

the vertical frame legs (21, 22) of the front grooved elements (20) are embodied L-shaped in cross section and with one leg form connecting faces for the side elements (30.1, 30.2).

20           8.       The secure cabinet in accordance with one of claims 1 to 7, characterized in that

the door elements (50) can be connected with the front and/or rear grooved elements (20 and/or 40), wherein the vertical frame legs (21, 22; 41, 42) of the grooved elements (20, 40) are provided with hinge and closure elements (25, 41; 51) at connecting points which are aligned with each other.

9. The secure cabinet in accordance with one of the preceding claims,

characterized in that

the front and the rear grooved elements (20, 40) are  
5 identically embodied.

10. A kit in accordance with one of the preceding claims,

characterized in that

fire-proof, gas-tight cable bulkhead elements are employed  
at least in part in place of the frame legs (23, 24, 43, 44).

10

11. The kit in accordance with one of the preceding claims,

characterized in that

several secure cabinets are lined up with each other and  
intervening side elements (30.1, 30.1) are omitted.

15

12. The secure cabinet in accordance with one of the preceding claims,

characterized in that

a rack structure (200) in the form of an equipped and wired  
20 unit is introduced into the secure cabinet and is connected therewith.

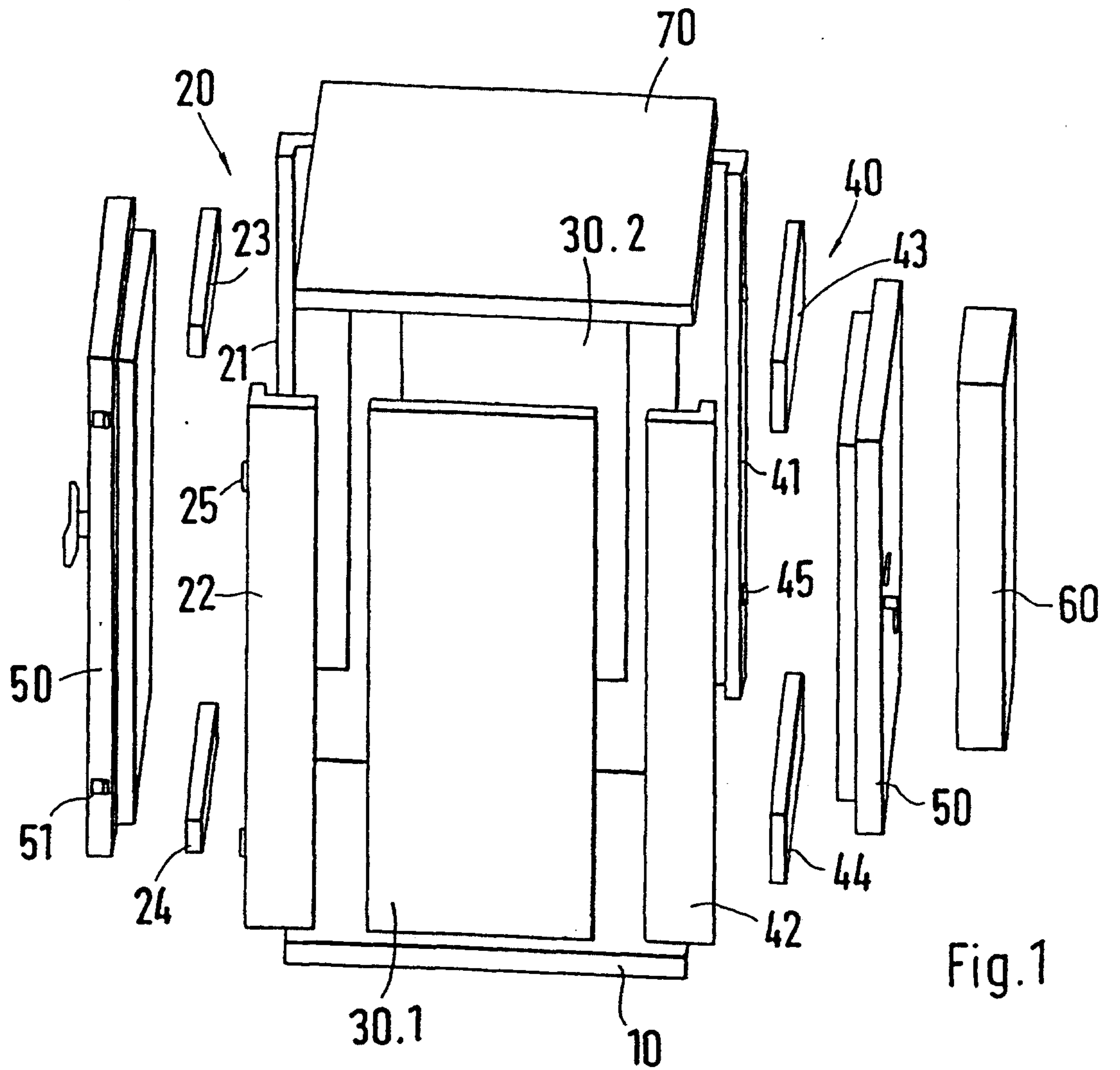

Fig. 1

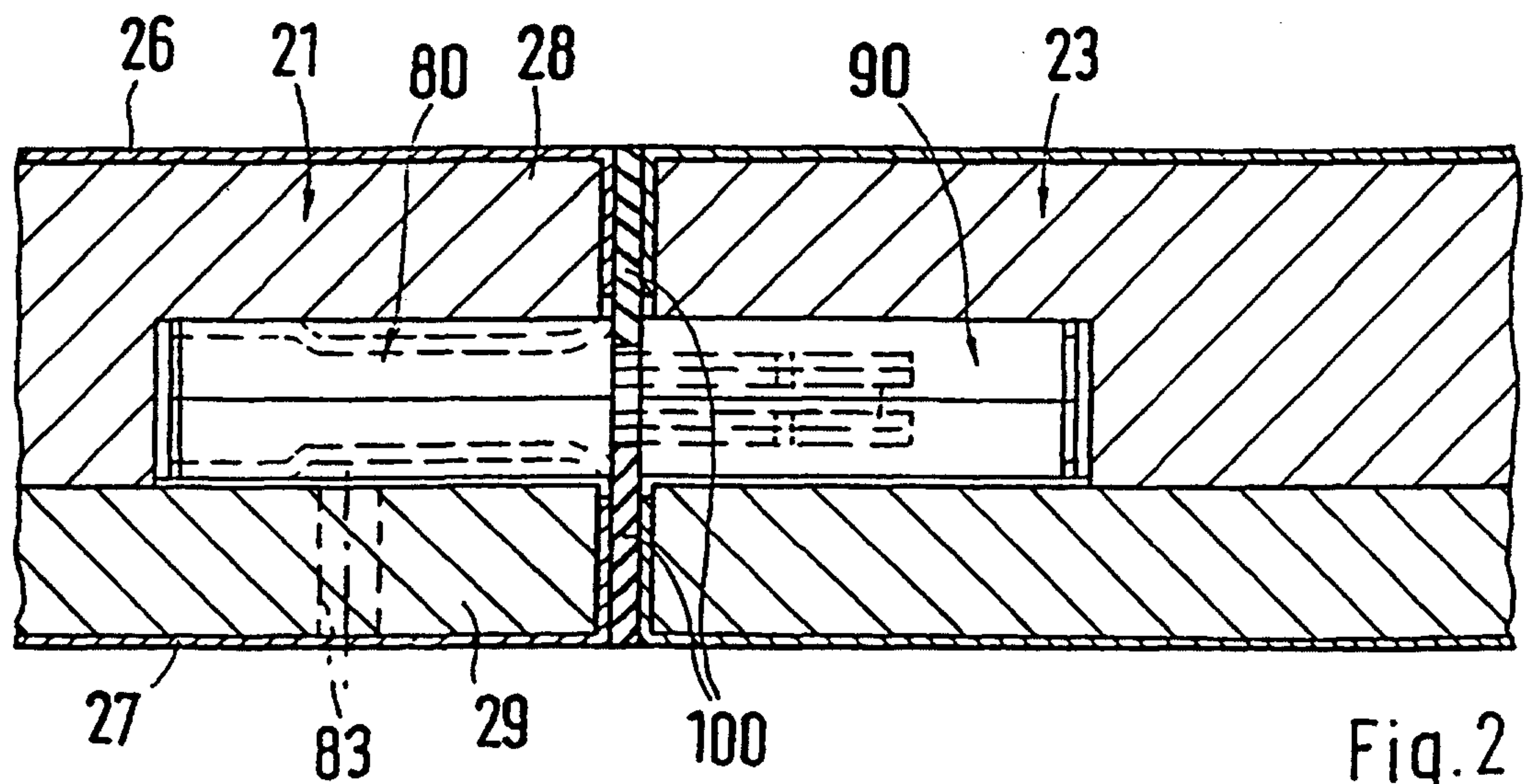

Fig. 2

2/2

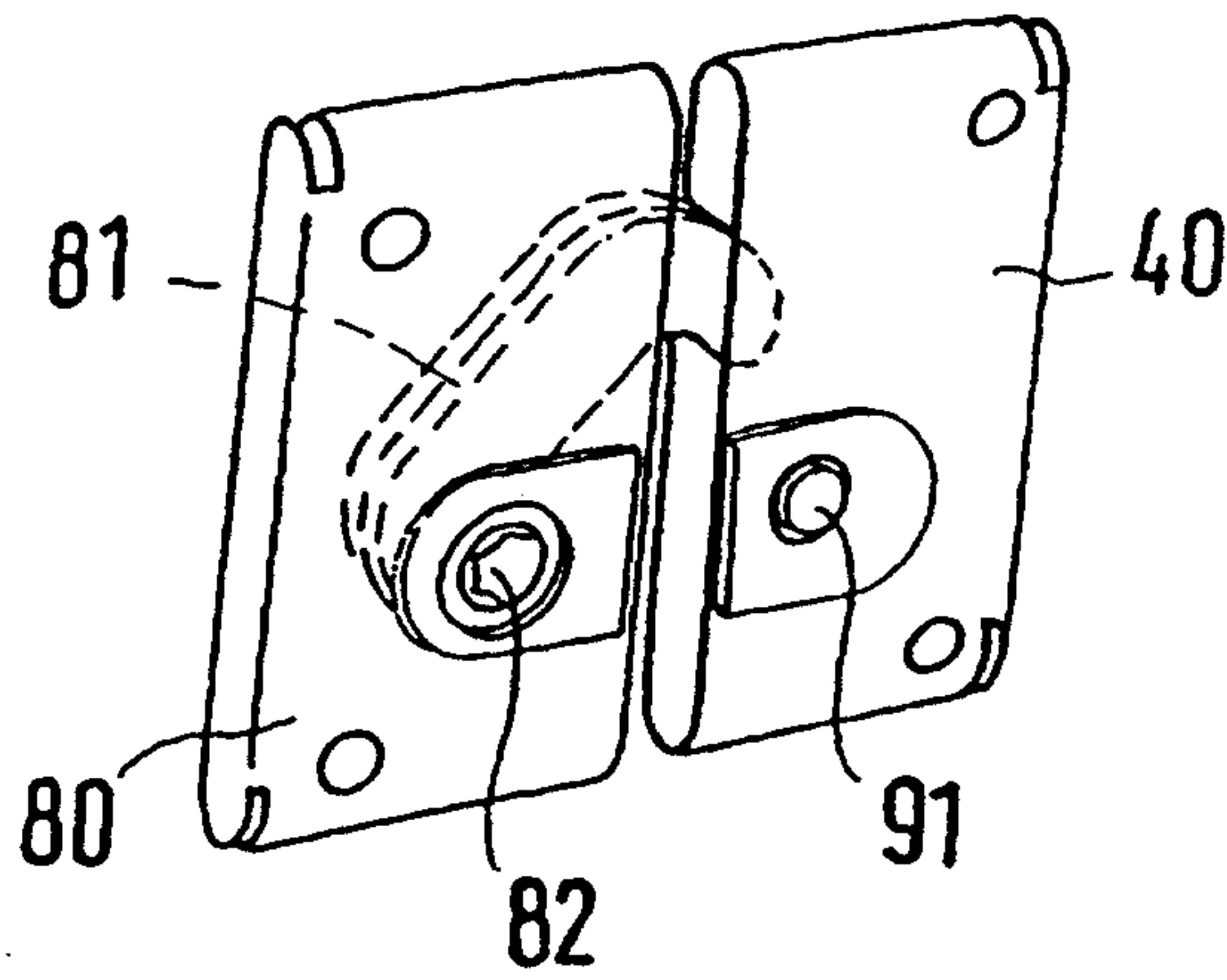

Fig. 3

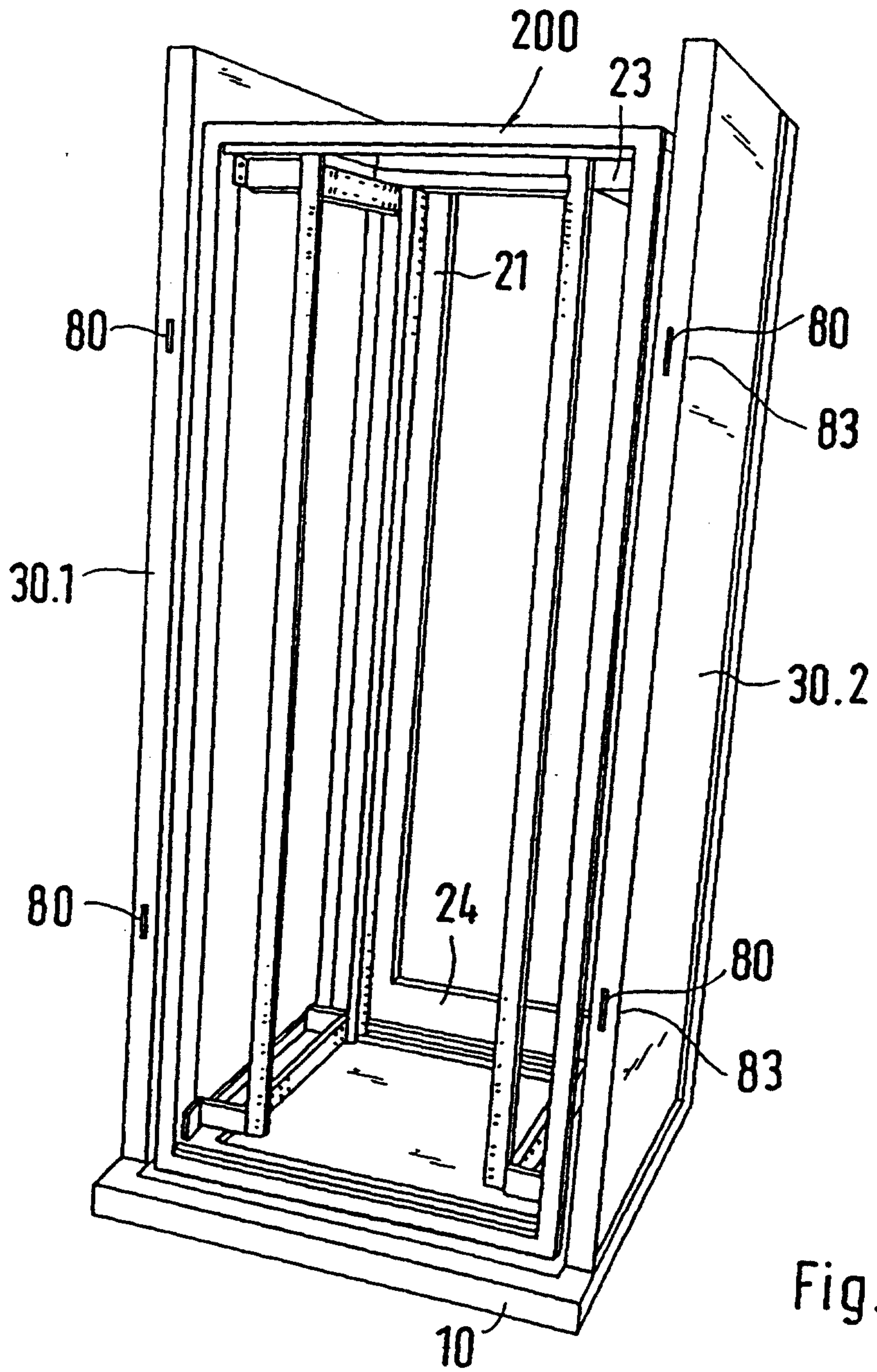

Fig. 4

