

Sept. 28, 1943.

A. T. HARVEY
MERCURY SWITCH

2,330,352

Filed Aug. 31, 1942

FIG. 1

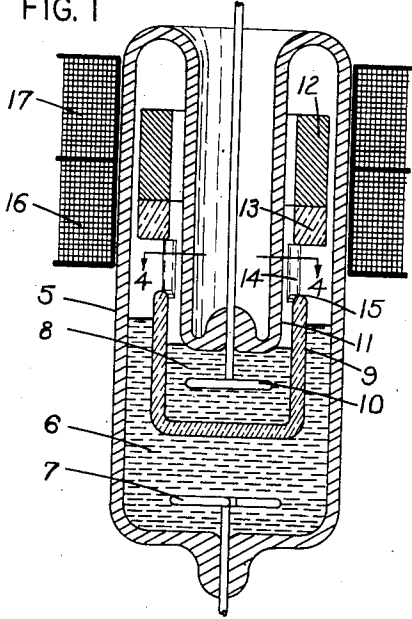

FIG. 2

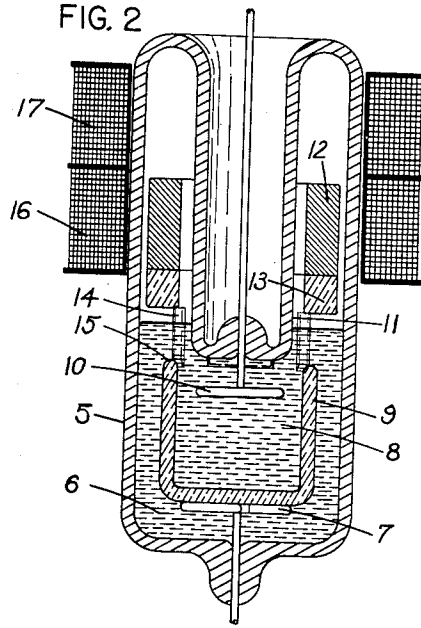

FIG. 3

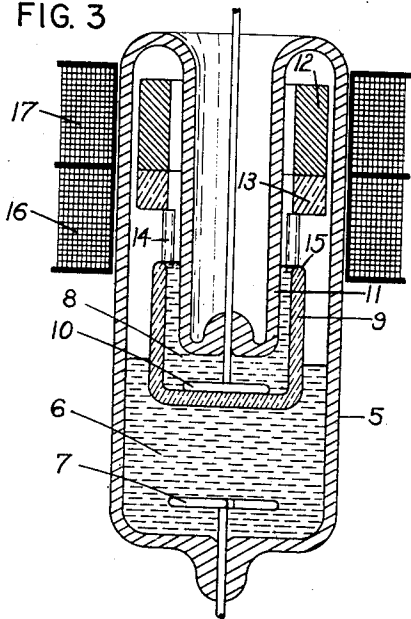
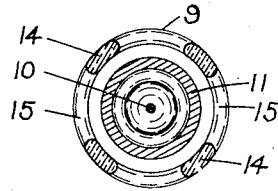

FIG. 4



WITNESSES:

R. C. Howard
Harold B. Keller

INVENTOR

Alexander T. Harvey

UNITED STATES PATENT OFFICE

2,330,352

MERCURY SWITCH

Alexander T. Harvey, Galveston, Tex.

Application August 31, 1942, Serial No. 456,759

10 Claims. (Cl. 200—112)

This invention relates to mercury switches, and more particularly to magnetically operated switches in which the electric circuit is "made" or "broken" by the joining or separating of mercury bodies within a sealed envelope.

There have been a considerable number of mercury switches devised, in which generally, a magnetically operated plunger displaces a quantity of mercury to effect electrical continuity between electrodes. For the most part, these switches require a continuous supply of electrical energy to their holding coils, for retaining the switch in at least one of its operating positions. This feature presents two main drawbacks.

First: The energy consumed by the holding coil of this type of switch is high, in as much as a considerable force is required to actuate the plunger into, and retain it in an increased displacement position due to the high density of the surrounding mercury.

Second: The continuous supply of energy to the holding coil must be dissipated in the form of heat. For the proper dissipation of this heat, the holding coil must be larger in physical proportions than is required solely for the production of its prescribed magnetic characteristics, resulting in proportionately larger manufacturing costs.

Certain mercury switches have been created in which springs or other mechanical latching devices have been resorted to for retaining the switch in either of its "on" or "off" positions. These devices always present the possibility of sticking, and are erratic in their operation with doubtful dependability.

It is therefore the object of this invention to provide a simple remotely controllable mercury switch, which requires energy for only a brief period during switching operations, and is free from the defects enumerated above.

Still further objects will be apparent to those skilled in the art, from the following description and its appended claims.

For attaining these objects, I employ a mercury switch with a displacement plunger normally floating upon a body of mercury, and which upon being shifted magnetically into an increased displacement position, effects the joining of normally separated mercury bodies, through which the electric circuit is completed, and itself becomes additionally weighted with mercury, whereupon it may be retained in its ("on") increased displacement position by gravity alone.

In breaking the electric circuit, the displacement plunger is magnetically raised above its

normal floating position, which results in the separation of the mercury bodies, and the removal of the weighting mercury from the plunger by displacement means, whereupon with the subsequent removal of the magnetic attraction means, the plunger descends slightly into the remains in its normal floating position in which the forces of buoyancy and gravity are in equilibrium.

10 An embodiment of my invention is shown in the accompanying drawing, in which

Fig. 1 is a sectional elevation showing the switch with its displacement plunger in an "off" position.

15 Fig. 2 is a sectional elevation showing the switch with its displacement plunger in an "on" position.

Fig. 3 is a sectional elevation showing the switch with its displacement plunger in its uppermost position, which is assumed at the start of each "off" period.

20 Fig. 4 is a sectional plan just above, and looking down upon the brim of the vessel portion of the displacement plunger, as indicated by the section line 4—4 in Fig. 1.

25 Referring to the drawing, and first to Fig. 1, an elongated cylindrical envelope 5 contains a body of mercury 6, making electrical contact with an electrode 7 which is sealed into the lower portion of the envelope 5. A second body of mercury 8 is contained in a vessel type displacement plunger 9 of insulating material, and which normally floats upon the mercury body 6. A second electrode 10 makes electrical contact with the mercury body 8 and is sealed in the lower end of an inward projecting member 11 of circular cross section, formed from the upper end of the envelope 5, and constituting a portion thereof.

30 The envelope 5 and its inward projecting member 11 are arranged concentrically with one another, and thus form a space of annular cross section therebetween. A cylindrical core 12, of magnetic material is attached to a rim member 13 at the upper end of the displacement plunger 9, and constitutes the armature thereof. The rim member 13 is attached to columnar members 14 extending upward from the brim 15 of the displacement plunger 9, as best shown in Fig. 4. The displacement plunger 9 with its armature 12 constitutes, in general, a hollow cylindrical combination, and is adapted to axial movement within the annular space between the envelope 5 and its inward projecting member 11.

35 Placed concentrically about the envelope 5 are two solenoid coils 16 and 17, which in combina-

tion with the armature 12 constitute an electromagnet. The solenoid coil 16 is positioned to attract the armature 12 upon being energized, and force the displacement plunger 9 downward from its free floating position as shown in Fig. 1, into its submerged position as shown in Fig. 2. As the displacement plunger 9 moves downward, the surface of the mercury body 6 rises due to the increased displacement, overflows the brim 15 and fills the interior of the displacement plunger 9, whereupon the mercury bodies 6 and 8 join and complete the electric circuit between the electrodes 7 and 10 as the displacement plunger 9 subsequently assumes its submerged position.

Upon being filled with mercury, the displacement plunger 9 becomes additionally weighted, and in effect, less buoyant. With this in mind, the armature 12 is proportioned in weight sufficiently to retain the displacement plunger 9 in its submerged position as shown in Fig. 2, irrespective of any magnetic attraction between the armature 12 and the solenoid coil 16. Thus as soon as the "make" is established, the excitation of the solenoid coil 16 may be removed, the switch remaining in its "on" position due to the force of gravity alone.

The solenoid coil 17 is positioned to attract and raise the armature 12 into the position as shown in Fig. 3 upon being excited. As the armature 12 with its attached displacement plunger 9 rises, the mercury bodies 6 and 8 separate at the brim 15, whereupon the electrical circuit between electrodes 7 and 10 is broken. Also, as the displacement plunger 9 rises, the inward projecting member 11 occupies an increasing portion of the interior of the displacement plunger 9, with the result that the portion of the mercury body 8 so displaced, overflows the brim 15 and joins with the mercury body 6.

Thus the displacement plunger 9 is lightened of a portion of its mercury contents, and with the removal of the excitation of the solenoid coil 17, settles slightly into its normal floating position as shown in Fig. 1, wherein it remains due to its re-established buoyancy.

The electrodes 7 and 10 are formed into circular rings at their inward projecting ends, and thus form resilient stops for limiting the axial movement of the displacement plunger 9.

While in accordance with the provisions of the statutes, I have illustrated and described the best form of embodiment of my invention now known to me, it will be apparent to those skilled in the art that changes may be made in the form of the apparatus disclosed without departing from the spirit of my invention as set forth in the appended claims.

Having now described my invention, what I claim is new and desire to secure by Letters Patent is:

1. A mercury switch comprising an envelope with spaced electrodes sealed therein, normally spaced mercury bodies contacting each of said electrodes, a plunger contained in said envelope, said plunger being adapted to join and separate said mercury bodies, and means for variably weighting said plunger whereby it may be retained in a state of equilibrium in either of its positions resulting in said joined or said separated states.

2. A mercury switch comprising an envelope with spaced electrodes sealed therein, normally spaced mercury bodies contacting each of said electrodes, a displacement plunger extending into one of said mercury bodies, means for varying

the displacement of said plunger whereby said mercury bodies may be joined and separated, and means for variably weighting said displacement plunger whereby it may be retained in a state of equilibrium in either of its positions resulting in said joined or said separated states independently of said varying displacement means.

3. A mercury switch comprising an envelope with spaced electrodes sealed therein, normally spaced mercury bodies contacting each of said electrodes, a variably weightable displacement plunger normally floating upon one of said mercury bodies, means for varying the displacement of said plunger whereby said mercury bodies may be joined and separated, and means for variably weighting said displacement plunger whereby it may be retained in either of its positions resulting in said joined or said separated states independently of said varying displacement means.

4. A mercury switch comprising an envelope with electrodes sealed therein, normally spaced mercury bodies contained in said envelope, an electrode extending into each of said mercury bodies, a variably weightable displacement plunger normally floating upon one of said mercury bodies, means for varying the displacement of said plunger whereby said mercury bodies may be joined and separated, and means for variably weighting said displacement plunger with mercury whereby it may be retained in either of its positions resulting in said joined or said separated states independently of said varying displacement means.

5. A mercury switch comprising an envelope with electrodes sealed therein, a body of mercury contained in said envelope, a variably weightable displacement plunger normally floating upon said mercury body, a second mercury body supported by said displacement plunger and constituting a portion thereof, said mercury bodies being normally space separated one from another, an electrode extending into each of said mercury bodies, means for varying the displacement of said plunger whereby said mercury bodies may be joined and separated, and means for variably weighting said displacement plunger with mercury whereby it may be retained in either of its positions resulting in said joined or said separated states independently of said varying displacement means.

6. A mercury switch comprising an envelope with electrodes sealed therein, normally spaced mercury bodies contained in said envelope, a brimmed vessel type displacement plunger normally floating upon one of said mercury bodies, a second mercury body contained in and partly filling the brimmed vessel portion of said displacement plunger, an electrode extending into each of said mercury bodies, means for submerging the brimmed vessel portion of said plunger whereupon said mercury bodies fill said vessel and join, said brimmed vessel remaining submerged independently of said submerging means upon being additionally weighted by said mercury fill, means for raising said plunger whereupon said mercury bodies separate at the brim of said vessel, and means for restoring the normal vessel fill whereby normal flotation of said brimmed vessel type displacement plunger is re-established.

7. A mercury switch comprising an envelope with electrodes sealed therein, normally spaced mercury bodies contained in said envelope, a brimmed vessel type displacement plunger normally floating upon one of said mercury bodies,

an armature of magnetic material attached to said displacement plunger, a second mercury body contained in and partly filling the brimmed vessel portion of said displacement plunger, an electrode extending into each of said mercury bodies, magnetic means for attracting said armature downward whereupon the brimmed vessel portion of said displacement plunger is submerged and filled, and said mercury bodies are joined, said brimmed vessel remaining submerged independently of said magnetic attraction means upon being additionally weighted by said mercury fill, magnetic means for attracting said armature upward whereupon said plunger is raised, and said mercury bodies are separated at the brim of said vessel, and means for restoring the normal vessel fill whereby normal flotation of said brimmed vessel type displacement plunger is re-established.

8. A mercury switch comprising an envelope with electrodes sealed therein, normally spaced mercury bodies contained in said envelope, a brimmed vessel type displacement plunger normally floating upon one of said mercury bodies, an armature of magnetic material attached to said displacement plunger, a second mercury body contained in and partly filling the brimmed vessel portion of said displacement plunger, an electrode extending into each of said mercury bodies, a solenoid coil positioned to attract said armature downward upon being energized, whereupon the brimmed vessel portion of said displacement plunger is submerged and filled, and said mercury bodies are joined, said brimmed vessel remaining submerged independently of said solenoid attraction upon being additionally weighted by said mercury fill, a second solenoid coil positioned to attract said armature upward upon being energized, whereupon said plunger is raised, and said mercury bodies are separated at the brim of said vessel, and displacement means for removing the excess mercury from said vessel whereby its normal fill and normal flotation are re-established.

9. A mercury switch comprising an envelope with electrodes sealed therein, normally spaced mercury bodies contained in said envelope, a brimmed vessel type displacement plunger normally floating upon one of said mercury bodies, an armature of magnetic material attached to said displacement plunger, a second mercury body contained in and partly filling the brimmed vessel portion of said displacement plunger, a stationary displacement member positioned above said brimmed vessel and extending therein, an electrode extending into each of said mercury bodies, a solenoid coil positioned to attract said

armature downward upon being energized, whereupon the brimmed vessel portion of said displacement plunger is submerged and filled, and said mercury bodies are joined, said brimmed vessel remaining submerged independently of said solenoid attraction upon being additionally weighted by said mercury fill, a second solenoid coil positioned to attract said armature upward upon being energized and raise said displacement plunger whereupon said mercury bodies separate at the brim of said vessel, said stationary displacement member being positioned to displace and cause that portion of the mercury in excess of the normal vessel fill to overflow said brim from within with the raising of said plunger above its normal floating position, whereupon said plunger resumes its normal floating position as said second solenoid coil becomes de-energized.

10. A mercury switch comprising an envelope with electrodes sealed therein, normally spaced mercury bodies contained in said envelope, a brimmed vessel type displacement plunger normally floating upon one of said mercury bodies, a cylindrical armature of magnetic material situated above the brimmed portion of said plunger and attached thereto, a second mercury body contained in and partly filling the brimmed vessel portion of said displacement plunger, an electrode extending into each of said mercury bodies, a stationary displacement member extending downward from the top of said envelope through said armature and into said brimmed vessel portion of said plunger, said stationary displacement member and the interior walls of said envelope forming an annular space within which said displacement plunger is arranged for axial movement, a solenoid coil positioned to attract said armature downward upon being energized, whereupon the brimmed vessel portion of said plunger is submerged and filled, and said mercury bodies are joined, said brimmed vessel remaining submerged independently of said solenoid attraction upon being additionally weighted by said mercury fill, a second solenoid coil positioned to attract said armature upward upon being energized and raise said displacement plunger whereupon said mercury bodies separate at the brim of said vessel, said stationary displacement member being positioned to displace and cause that portion of the mercury in excess of the normal vessel fill to overflow said brim from within with the raising of said plunger above its normal floating position, whereupon said plunger resumes its normal floating position as said second solenoid coil becomes de-energized.

ALEXANDER T. HARVEY.