

(19) World Intellectual Property Organization
International Bureau



(43) International Publication Date
27 June 2002 (27.06.2002)

PCT

(10) International Publication Number
WO 02/51188 A1

(51) International Patent Classification⁷: **H04Q 7/38**,
H04L 29/12

(81) Designated States (*national*): AE, AG, AL, AM, AT, AU, AZ, BA, BB, BG, BR, BY, BZ, CA, CH, CN, CR, CU, CZ, DE, DK, DM, DZ, EE, ES, FI, GB, GD, GE, GH, GM, HR, HU, ID, IL, IN, IS, JP, KE, KG, KP, KR, KZ, LC, LK, LR, LS, LT, LU, LV, MA, MD, MG, MK, MN, MW, MX, MZ, NO, NZ, PL, PT, RO, RU, SD, SE, SG, SI, SK, SL, TJ, TM, TR, TT, TZ, UA, UG, US, UZ, VN, YU, ZA, ZW.

(21) International Application Number: PCT/EP00/13119

(22) International Filing Date:
21 December 2000 (21.12.2000)

(25) Filing Language: English

(84) Designated States (*regional*): ARIPO patent (GH, GM, KE, LS, MW, MZ, SD, SL, SZ, TZ, UG, ZW), Eurasian patent (AM, AZ, BY, KG, KZ, MD, RU, TJ, TM), European patent (AT, BE, CH, CY, DE, DK, ES, FI, FR, GB, GR, IE, IT, LU, MC, NL, PT, SE, TR), OAPI patent (BF, BJ, CF, CG, CI, CM, GA, GN, GW, ML, MR, NE, SN, TD, TG).

(26) Publication Language: English

(71) Applicant (*for all designated States except US*): **NOKIA CORPORATION** [FI/FI]; Keilalahdentie 4, FIN-02150 Espoo (FI).

Published:
— with international search report

(72) Inventors; and

(75) Inventors/Applicants (*for US only*): **STAACK, Jens** [FI/FI]; Nokia Networks Oy, Keilalahdentie 4, FIN-02150 Espoo (FI). **LOUGHNEY, John** [FI/FI]; Nokia Networks Oy, Keilalahdentie 4, FIN-02150 Espoo (FI).

For two-letter codes and other abbreviations, refer to the "Guidance Notes on Codes and Abbreviations" appearing at the beginning of each regular issue of the PCT Gazette.

(74) Agents: **LESON, Thomas, Johannes, Alois** et al.; Bavariaring 4, 80336 München (DE).

(54) Title: OVER-THE-AIR (OTA) SERVICE PROVISIONING IN A MOBILE COMMUNICATIONS SYSTEM

```

*) Response:
$ORIGIN 7.6.5.4.3.2.1.0.5.8.5.3.e164.arpa
IN NAPTR 102 10 "u"mailgw
IN NAPTR 102 10 "u"wapgw
IN NAPTR 102 10 "u"provisioning_server
IN NAPTR 102 10 "u"default_proxy_settings"
!^.*$!mailgw_1.sonera.net!
!^.*$!192.56.78.3!
!^.*$!prov_server.sonera.net!
!^.*$!dev_proxy.pac!

```

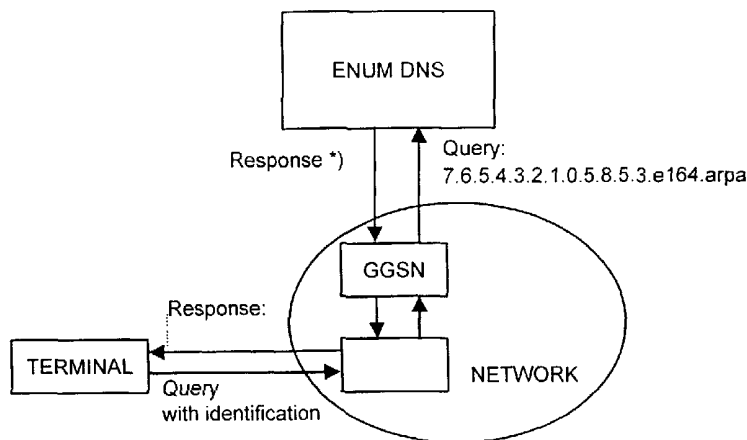

(57) Abstract: A method and a system for using IETF ENUM for provisioning services to terminals in a communication network system are provided. According to the method, entries are provided in an ENUM serving means in correspondence with codes of terminal identifications. Then, the ENUM serving means may be queried by a terminal on the basis of an identification of the terminal, and returns records corresponding to a code of the terminal identification to the querying terminal.



WO 02/51188 A1

- 1 -

TITLE OF THE INVENTION

OVER-THE-AIR (OTA) SERVICE PROVISIONING IN A MOBILE COMMUNICATIONS SYSTEM

5 FIELD OF THE INVENTION

The present invention relates to providing a terminal with information, parameters and/or settings required to obtain services subscribed to the terminal.

10

BACKGROUND OF THE INVENTION

Service provisioning means to provide a terminal which may be a new "blank" terminal, with the needed information, parameters and/or settings required to obtain services
15 subscribed to the terminal. The needed information, parameters and/or settings may include for instance communication network parameters, such as GPRS (General Packet Radio Service) parameters or UMTS (Universal Mobile
20 Telecommunication System) parameters, WAP (Wireless Application Protocol) parameters comprising a WAP Gateway address, a URL (Uniform Resource Locator) for Setup, a Home page and Favorites, WWW (World Wide Web) parameters comprising an HTTP (Hyper Text Transfer Protocol) Proxy
25 address, SMTP/POP3 addresses, a URL for Setup, a Home page and Favorites, Public keys, IPv4, IPv6 and a Default Classmark for multi-classmark devices.

Service provisioning of terminals can be done either manually
30 by the user who enters the parameters into the terminal, or somehow automated. There are several possibilities to provide the terminal with the needed information, parameters or settings, e.g. the terminal contacts a dedicated service provisioning server. For example, for WAP service
35 provisioning, a user sends an SMS (Short Message Service) to

- 2 -

a predefined number "400" with the content "WAP", for example, and gets the WAP parameters pushed via SMS.

Having the user input data into the terminal risks human
5 error. Human errors are less probable by using an automatic
system. However, conventionally, a plurality of automatic
systems has to be used to provide the terminal with all the
information, parameters and settings required for the
terminal to contact dedicated services on the respective
10 service provisioning servers.

SUMMARY OF THE INVENTION

It is therefore an object of the present invention to provide
15 a single method and system for provisioning services in an
improved manner.

According to an aspect of the present invention, this object
is achieved by a method of using IETF ENUM for provisioning
20 services to terminals in a communication network system, said
method comprising the steps of:

providing entries in an ENUM serving means in
correspondence with codes of terminal identifications;

25 querying the ENUM serving means by a terminal on the
basis of an identification of the terminal; and

returning records corresponding to a code of the
terminal identification from the ENUM serving means to the
querying terminal.

30 According to another aspect of the present invention, the
above-mentioned object is achieved by a communication network
system for using IETF ENUM for provisioning services to
terminals in the system, said system comprising:

ENUM serving means having entries in correspondence with
35 codes of terminal identifications;

- 3 -

wherein, when a terminal queries the ENUM serving means on the basis of an identification of the terminal, the ENUM serving means returns records corresponding to a code of the terminal identification to the querying terminal.

5

The terminal examines the records returned from the ENUM serving means and determines service data on the basis of the examined records. The service data may comprise information, parameters and/or settings for obtaining services on a
10 service provisioning server by the terminal.

The system may further comprise formatting means for receiving the terminal identification of the querying terminal, for formatting the terminal identification to a
15 corresponding terminal identification code, and for querying the ENUM serving means on the code.

The ENUM serving means may have entries for the full code of a terminal identification and/or for a part of the code of a
20 terminal identification.

In addition, the ENUM serving means may have entries which are the same for a group of terminals.

25 The ENUM serving means may also have entries for a lookup on a further serving means.

A new blank terminal may perform the query of the ENUM serving means, and/or the query of the ENUM serving means may
30 be performed every time a new session is activated. Moreover, the query may be performed for updating services, and/or for provisioning new services.

The terminal identification may be the MSISDN of the terminal
35 or a user's name.

- 4 -

The information, parameters and/or settings may comprise communication network parameters such as GPRS parameters and UMTS parameters, WAP parameters, a WAP gateway address, a URL for Setup, a Home page, Favorites , Public keys, IPv4, IPv6, 5 a Default Classmark for multi-classmark devices, software updates, applets, a network storage location, user preference list and firmware updates.

Moreover, the ENUM serving means may be implemented in a DNS 10 server in a data network.

According to a further aspect of the present invention, the above-mentioned object may be achieved by an apparatus using IETF ENUM for provisioning services to terminals in a 15 communication network system, said apparatus having entries in correspondence with codes of terminal identifications;

wherein, when a terminal queries said apparatus on the basis of an identification of the terminal, said apparatus returns records corresponding to a code of the terminal 20 identification to the querying terminal.

According to a still further aspect of the present invention, the above-mentioned object may be achieved by a user terminal for communicating with a network system using IETF ENUM for 25 provisioning services to terminals in the system,

wherein the user terminal is adapted to query an ENUM serving means having entries in correspondence with codes of terminal identifications, on the basis of an identification of the user terminal. 30

Moreover, the user terminal may examine records returned from the ENUM serving means upon the query, the records corresponding to a code of the terminal identification, and determine service data on the basis of the examined records. 35

- 5 -

According to the present invention, the information, parameters and settings enabling the terminal to obtain services on respective service provisioning servers are provisioned to the terminal by an ENUM serving means such as an ENUM DNS (ENUM Domain Name Server) with only the terminal identification such as the MSISDN (ISDN number for Mobile Subscriber) defined, and all the services are in use immediately as they are defined in the DNS. New functionalities and properties for "blank" terminals can be defined fast in a scaleable manner. In addition, services for users with different capabilities can be provided. The terminal only needs to know how to use the records returned from the DNS. Human errors are less probable by using the automatic system according to the present invention. Further advantages of the present invention are that ENUM is scalable, flexible and cheap to implement as it can use standard DNS servers.

BRIEF DESCRIPTION OF THE DRAWINGS

20

Fig. 1 shows a schematic diagram of a service provisioning system according to the present invention.

Fig. 2 shows a flowchart of steps performed in the service provisioning system according to the present invention.

Fig. 3 shows a schematic diagram of a service provisioning system according to an embodiment of the present invention.

DESCRIPTION OF THE PREFERRED EMBODIMENT

The idea of the present invention is to use IETF (Internet Engineering Task Force) ENUM for provisioning services to terminals in a communication network system. ENUM is an IETF standardized system for providing address translations between telephone numbers and URLs. It provides a system for

- 6 -

starting different ways of communication with a device associated to the input phone number.

In the following, the concept of the present invention will
5 be described with respect to Figs. 1 and 2.

As shown in Fig. 1, a terminal which may be a new "blank" terminal queries an ENUM serving means on the basis of its terminal identification. The terminal identification may be
10 the MSISDN of the terminal, a terminal user's name or anything that identifies the terminal or user. The terminal performs the query by sending its identification, e.g. by calling its own MSISDN, sending a message such as SMS or USSD including the identification. The terminal identification is
15 directed through the network to which the terminal attaches and routed to the ENUM serving means. The terminal identification is formatted into an ENUM request format transparently on the way. The formatting can take place e.g. in the requesting terminal itself, or in any appropriate
20 network element provided with translation capability. In this embodiment the formatting means is located in connection with the GGSN. The purpose of formatting is to format the terminal identification into a code understandable by the ENUM serving means. The code is sent to the ENUM serving
25 means for a lookup on the code. The ENUM serving means returns a set of records for the queried code to the terminal via the formatting means and the network.

According to Fig. 2, in a first step, the ENUM serving means
30 is provided with entries for terminal identification codes. These entries can be on different levels which will be described later. When an ENUM serving means lookup on the basis of a terminal identification is performed as indicated in the second step of Fig. 2, the ENUM serving means returns
35 a set of records for the terminal identification according to the third step of Fig. 2. The terminal then examines the

- 7 -

returned records and determines service data therefrom. The service data comprise the needed information, parameters and/or settings to obtain services subscribed to the terminal. The needed information, parameters and/or settings
5 may include communication network related parameters such as GPRS parameters or UMTS parameters, WAP parameters comprising a WAP Gateway address, a URL for Setup, a Home page and Favorites, WWW parameters comprising an HTTP Proxy address, SMTP/POP3 addresses, a URL for Setup, a Home page and
10 Favorites, Public keys, IPv4, IPv6, a Default Classmark for multi-classmark devices, software updates, applets, network storage location, a user preference list, firmware updates, etc.

15 According to the present invention, an ENUM serving means query is performed by the terminal and data are returned to the terminal. The query can be performed only once by a new "blank" terminal or every time a new session or context is activated or as often as needed also during a session or
20 context, e.g. in order to update services or to provision new services.

In the following, a preferred embodiment of the present invention will be described with respect to Fig. 3.

25

According to the preferred embodiment, the terminal identification is the MSISDN number of the terminal. The ENUM serving means is implemented in a DNS. When a user gets a blank terminal, i.e. a terminal without any information,
30 parameters or settings, and a SIM (GSM Subscriber Identity Module) card with the MSISDN +358 50 123 45 67, for example, the blank terminal gets the needed parameters by making an ENUM query, as it is shown in Fig. 3. The E.164 number is formatted into the code 7.6.5.4.3.2.1.0.5.8.5.3.e164.arpa,
35 and the ENUM DNS is queried on this code. The formatting of the query can take place in the terminal, or in any network

- 8 -

element on the way which is provided with the capability of formatting. As an example of this, in the present embodiment the GGSN network element is provided with means for formatting. The query from the terminal can take place e.g. by making a call to the MS's own MSISDN, or by sending a message to the network. As a response on the query, the ENUM DNS returns the following record for the code 7.6.5.4.3.2.1.0.5.8.5.3.e164.arpa:

```

10 $ORIGIN 7.6.5.4.3.2.1.0.5.8.5.3.e164.arpa
   IN NAPTR 102 10 "u""mailgw"           "!^.*$!mailgw_1.sonera.net!".
   IN NAPTR 102 10 "u""wapgw"           "!^.*$!192.56.78.3!".
   IN NAPTR 102 10 "u""provisioning_server" "!^.*$!prov_server.sonera.net!".
   IN NAPTR 102 10 "u""default_proxy_settings" "!^.*$!dev_proxy.pac!".

```

15

The DNS entries can also be on different levels. This means that there can be DNS entries which are the same for all users of one operator's network, e.g. the WAP Gateway, represented by the following entry in the DNS:

20

```

$ORIGIN 5.8.5.3.e164.arpa
IN NAPTR 102 10 "u" "wapgw"           "!^.*$!192.56.78.3!".

```

Also, the DNS can be used for loadsharing. According to the example of the WAP Gateway, the DNS entry becomes:

25

```

$ORIGIN 5.8.5.3.e164.arpa
IN NAPTR 102 10 "u" "wapgw"           "!^.*$!wapgw.sonera.com".

```

30 A further lookup on wapgw.sonera.com returns:

```

;;
   Pref Weight Port Target
   wapgw.sonera.com IN SRV 0 0 1000 glc1.nokia.com
   IN SRV 0 0 1000 192.56.78.0
35   IN SRV 0 0 1000 192.56.78.1
   IN SRV 0 0 1000 192.56.78.2

```

Moreover, there can be entries in the DNS for a group of users with the same number range (like +358 50 77X XXXX, e.g.

- 9 -

for all Nokia employees) of a network operator. Then, the entry of the mail gateway, for example, is:

```
$ORIGIN 7.7.0.5.8.5.3.e164.arpa
5 IN NAPTR 102 10 "u" "mailgw_nokia" "!^.*$!mailgw_nokia.nokia.com!" .
```

Furthermore, in case of load sharing in e.g. services or resources based on a number range, e.g. there may be entries of different MMS relays for number range +358 50 5XX XXXX -> MMS relay 1, and number range +358 50 6XX XXXX -> MMS relay 2:

```
$ORIGIN 5.0.5.8.5.3.e164.arpa
15 IN NAPTR 102 10 "u" "mmservice+E2U"
    "!^.*$!smtp:0407499122@mmmsrelay_1.sonera.net"
and
```

```
$ORIGIN 6.0.5.8.5.3.e164.arpa
20 IN NAPTR 102 10 "u" "mmservice+E2U"
    "!^.*$!smtp:0407499122@mmmsrelay_2.sonera.net"
```

In addition, there can be DNS entries for a single MSISDN of a network operator, e.g. the SIP URL, tel, email address, and the MMS relay entry becomes:

```
25 $ORIGIN 2.2.1.9.9.4.7.0.4.8.5.3.e164.arpa
    IN NAPTR 102 10 "u" "sip+E2U" "!^.*$!sip:john.loughney@sonera.net!".
    IN NAPTR 102 10 "u" "mailto+E2U" "!^.*$!mailto:0501234567@sonera_messi.net!".
    IN NAPTR 102 10 "u" "tel+E2U" "!^.*$!tel:+358407499122!".
```

30 As can be seen from the foregoing, using ENUM for service provisioning yields a scaleable and flexible system and method which is cheap to implement and reduces the change of human errors.

35 While the invention has been described with reference to a preferred embodiment, the description is illustrative of the invention and is not to be construed as limiting the invention. Various modifications and applications may occur

- 10 -

to those skilled in the art without departing from the true spirit and scope of the invention as defined by the appended claims.

- 11 -

CLAIMS:

1. A method of using IETF ENUM for provisioning services to terminals in a communication network system, said method
5 comprising the steps of:
 providing entries in an ENUM serving means in
correspondence with codes of terminal identifications;
 querying the ENUM serving means by a terminal on the
basis of an identification of the terminal; and
10 returning records corresponding to a code of the
terminal identification from the ENUM serving means to the
querying terminal.
2. A method according to claim 1, comprising the further step
15 of:
 examining the records returned from the ENUM serving
means by the terminal and determining service data on the
basis of the examined records.
- 20 3. A method according to claim 2, wherein the service data
comprise information, parameters and/or settings for
obtaining services on a service provisioning server by the
terminal.
- 25 4. A method according to claim 1, wherein the querying step
comprises the step of:
 formatting the terminal identification to a
corresponding terminal identification code and querying the
ENUM serving means on the code.
30
5. A method according to claim 1, wherein the ENUM serving
means is provided with entries for the full code of a
terminal identification.

- 12 -

6. A method according to claim 1, wherein the ENUM serving means is provided with entries for a part of the code of a terminal identification.
- 5 7. A method according to claim 1, wherein the ENUM serving means is provided with entries which are the same for a group of terminals.
8. A method according to claim 1, wherein the ENUM serving
10 means is provided with entries for a lookup on a further serving means.
9. A method according to claim 1, wherein the querying step is performed by a new blank terminal.
- 15 10. A method according to claim 1, wherein the querying step is performed every time a new session is activated.
11. A method according to claim 1, wherein the querying step
20 is performed for updating services.
12. A method according to claim 1, wherein the querying step is performed for provisioning new services.
- 25 13. A method according to claim 1, wherein the terminal identification is the MSISDN of the terminal.
14. A method according to claim 1, wherein the terminal identification is a user's name.
- 30 15. A method according to claim 3, wherein the information, parameters and/or settings comprise communication network parameters, WAP parameters, a WAP gateway address, a URL for Setup, a Home page, Favorites , Public keys, IPv4, IPv6, a
35 Default Classmark for multi-classmark devices, software

- 13 -

updates, applets, a network storage location, user preference list and firmware updates.

16. A method according to claim 1, wherein the ENUM serving
5 means is implemented in a DNS server in a data network.

17. A communication network system for using IETF ENUM for provisioning services to terminals in the system, said system comprising:

10 ENUM serving means having entries in correspondence with codes of terminal identifications;

wherein, when a terminal queries the ENUM serving means on the basis of an identification of the terminal, the ENUM serving means returns records corresponding to a code of the
15 terminal identification to the querying terminal.

18. A system according to claim 17, wherein the terminal examines the records returned from the ENUM serving means and determines service data on the basis of the examined records.

20

19. A system according to claim 18, wherein the service data comprise information, parameters and/or settings for obtaining services on a service provisioning server by the terminal.

25

20. A system according to claim 17, further comprising:

formatting means for receiving the terminal identification of the querying terminal, for formatting the terminal identification to a corresponding terminal
30 identification code, and for querying the ENUM serving means on the code.

21. A system according to claim 17, wherein the ENUM serving means has entries for the full code of a terminal
35 identification.

- 14 -

22. A system according to claim 17, wherein the ENUM serving means has entries for a part of the code of a terminal identification.
- 5 23. A system according to claim 17, wherein the ENUM serving means has entries which are the same for a group of terminals.
24. A system according to claim 17, wherein the ENUM serving
10 means has entries for a lookup on a further serving means.
25. A system according to claim 17, wherein a new blank terminal performs the query of the ENUM serving means.
- 15 26. A system according to claim 17, wherein a terminal performs the query of the ENUM serving means every time a new session is activated.
27. A system according to claim 17, wherein a terminal
20 performs the query of the ENUM serving means for updating services.
28. A system according to claim 17, wherein a terminal performs the query of the ENUM serving means for provisioning
25 new services.
29. A system according to claim 17, wherein the terminal identification is the MSISDN of the terminal.
- 30 30. A system according to claim 17, wherein the terminal identification is a user's name.
31. A system according to claim 19, wherein the information, parameters and/or settings comprise communication network
35 parameters, WAP parameters, a WAP gateway address, a URL for Setup, a Home page, Favorites, Public keys, IPv4, IPv6, a

- 15 -

Default Classmark for multi-classmark devices, software updates, applets, a network storage location, user preference list and firmware updates.

5 32. A system according to claim 17, wherein the ENUM serving means is implemented in a DNS server in a data network.

33. An apparatus using IETF ENUM for provisioning services to terminals in a communication network system, said apparatus
10 having entries in correspondence with codes of terminal identifications;

wherein, when a terminal queries said apparatus on the basis of an identification of the terminal, said apparatus returns records corresponding to a code of the terminal
15 identification to the querying terminal.

34. An apparatus according to claim 33, wherein said apparatus has entries for the full code of a terminal
20 identification.

35. An apparatus according to claim 33, wherein said apparatus has entries for a part of the code of a terminal
identification.

25 36. An apparatus according to claim 33, wherein said apparatus has entries which are the same for a group of terminals.

37. An apparatus according to claim 33, wherein said
30 apparatus has entries for a lookup on a further serving means.

38. An apparatus according to claim 33, wherein the terminal
identification is the MSISDN of the terminal.

35

- 16 -

39. An apparatus according to claim 33, wherein the terminal identification is a user's name.

40. An apparatus according to claim 33, wherein said
5 apparatus is implemented in a DNS server in a data network.

41. A user terminal for communicating with a network system using IETF ENUM for provisioning services to terminals in the system,

10 wherein said user terminal is adapted to query an ENUM serving means having entries in correspondence with codes of terminal identifications, on the basis of an identification of said user terminal.

15 42. A user terminal according to claim 41, wherein said user terminal is adapted to examine records returned from the ENUM serving means upon the query, the records corresponding to a code of the terminal identification, and to determine service data on the basis of the examined records.

20

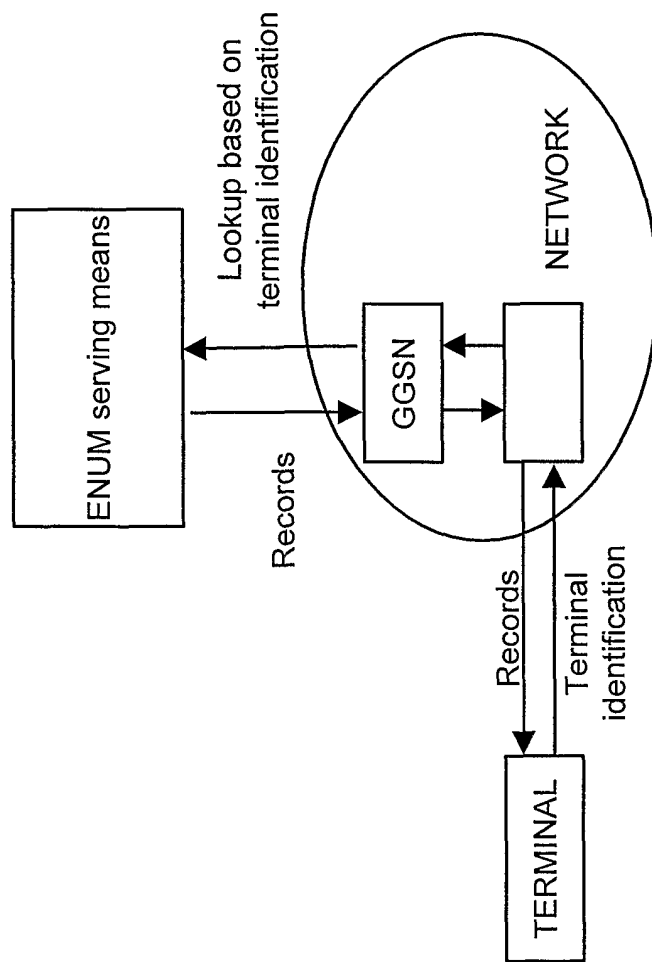
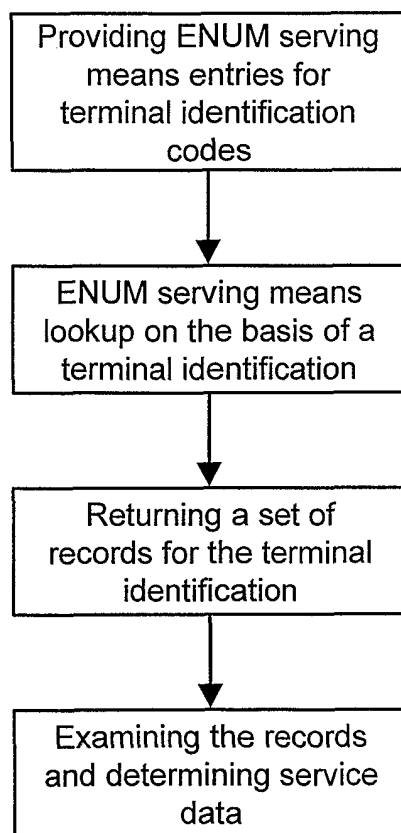

Fig. 1

2/3

**Fig. 2**

*) Response:
 \$ORIGIN 7.6.5.4.3.2.1.0.5.8.5.3.e164.arpa
 IN NAPTR 102 10 "u" mailgw"
 IN NAPTR 102 10 "u" wapgw"
 IN NAPTR 102 10 "u" provisioning_server"
 IN NAPTR 102 10 "u" default_proxy_settings"

"!^.*\$!mailgw_1.sonera.net!"
 "!^.*\$!192.56.78.3!"
 "!^.*\$!prov_server.sonera.net!"
 "!^.*\$!dev_proxy.paci!"

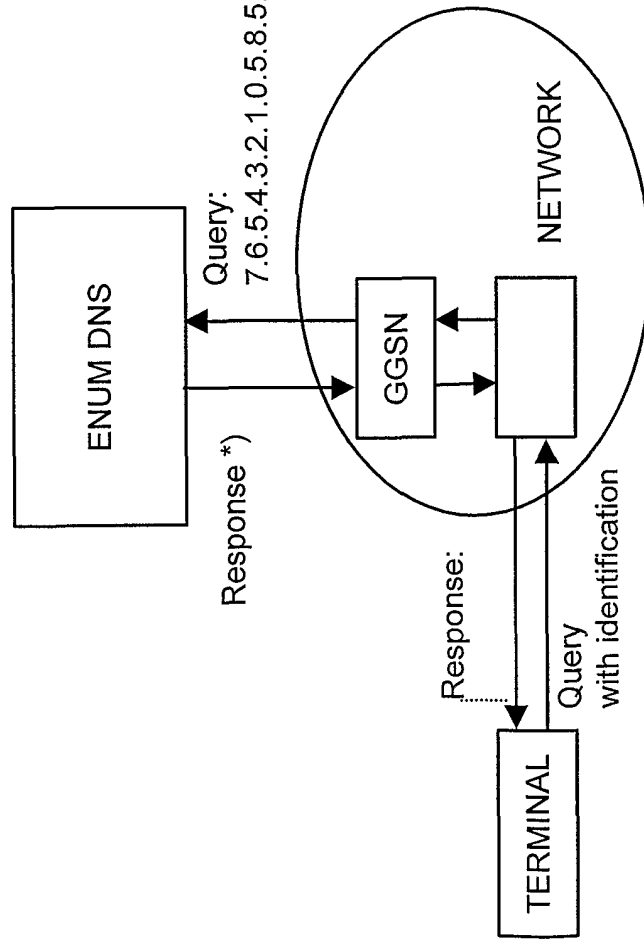

Fig. 3

INTERNATIONAL SEARCH REPORT

Application No
PCT/EP 00/13119A. CLASSIFICATION OF SUBJECT MATTER
IPC 7 H04Q7/38 H04L29/12

According to International Patent Classification (IPC) or to both national classification and IPC

B. FIELDS SEARCHED

Minimum documentation searched (classification system followed by classification symbols)
IPC 7 H04Q H04L

Documentation searched other than minimum documentation to the extent that such documents are included in the fields searched

Electronic data base consulted during the international search (name of data base and, where practical, search terms used)
EPO-Internal, WPI Data

C. DOCUMENTS CONSIDERED TO BE RELEVANT

Category *	Citation of document, with indication, where appropriate, of the relevant passages	Relevant to claim No.
A	WO 99 18515 A (INTEL CORP ;ANDERSEN DAVID B (US); BRANDEWIE DIRK J (US)) 15 April 1999 (1999-04-15) the whole document ---	1-42
A	EP 1 043 906 A (PHONE COM INC) 11 October 2000 (2000-10-11) column 4, line 54 -column 10, line 49 ---	1-42
A	TAYLOR A: "OVER-THE-AIR SERVICE PROVISIONING" ANNUAL REVIEW OF COMMUNICATIONS, NATIONAL ENGINEERING CONSORTIUM, CHICAGO, IL, US, vol. 51, 1998, pages 953-959, XP000793196 ISSN: 0886-229X the whole document ---	1-42
	-/--	

 Further documents are listed in the continuation of box C. Patent family members are listed in annex.

* Special categories of cited documents:

- *A* document defining the general state of the art which is not considered to be of particular relevance
- *E* earlier document but published on or after the international filing date
- *L* document which may throw doubts on priority claim(s) or which is cited to establish the publication date of another citation or other special reason (as specified)
- *O* document referring to an oral disclosure, use, exhibition or other means
- *P* document published prior to the international filing date but later than the priority date claimed

- *T* later document published after the international filing date or priority date and not in conflict with the application but cited to understand the principle or theory underlying the invention
- *X* document of particular relevance; the claimed invention cannot be considered novel or cannot be considered to involve an inventive step when the document is taken alone
- *Y* document of particular relevance; the claimed invention cannot be considered to involve an inventive step when the document is combined with one or more other such documents, such combination being obvious to a person skilled in the art.
- *&* document member of the same patent family

Date of the actual completion of the international search

31 August 2001

Date of mailing of the international search report

06/09/2001

Name and mailing address of the ISA

European Patent Office, P.B. 5818 Patentlaan 2
NL - 2280 HV Rijswijk
Tel. (+31-70) 340-2040, Tx. 31 651 epo nl,
Fax: (+31-70) 340-3016

Authorized officer

Roberti, V

INTERNATIONAL SEARCH REPORT

Application No
PCT/EP 00/13119

C.(Continuation) DOCUMENTS CONSIDERED TO BE RELEVANT		
Category °	Citation of document, with indication, where appropriate, of the relevant passages	Relevant to claim No.
A	WO 98 51100 A (NOKIA MOBILE PHONES LTD ;SHAH BHARAT (US)) 12 November 1998 (1998-11-12) page 11, line 24 -page 18, line 16 -----	1-42

INTERNATIONAL SEARCH REPORT

Application No
PCT/EP 00/13119

Patent document cited in search report		Publication date	Patent family member(s)	Publication date
WO 9918515	A	15-04-1999	US 5974453 A	26-10-1999
			AU 9031398 A	27-04-1999
			EP 1029292 A	23-08-2000

EP 1043906	A	11-10-2000	CN 1270452 A	18-10-2000
			JP 2000358282 A	26-12-2000

WO 9851100	A	12-11-1998	US 6029065 A	22-02-2000
			AU 7134498 A	27-11-1998
			EP 0877531 A	11-11-1998
