

(19) World Intellectual Property Organization  
International Bureau



(43) International Publication Date  
17 January 2008 (17.01.2008)

PCT

(10) International Publication Number  
**WO 2008/007053 A2**

(51) International Patent Classification:  
*B60N 3/10* (2006.01)

[GB/GB]; 51 Barony Road, Nantwich, Cheshire CW5 5QL (GB).

(21) International Application Number:  
PCT/GB2007/002503

(74) Agents: **DOWNEY, William, Gerrard** et al.; Wilson Gunn, 5th Floor, Blackfriars House, The Parsonage, Manchester M3 2JA (GB).

(22) International Filing Date: 5 July 2007 (05.07.2007)

(81) Designated States (unless otherwise indicated, for every kind of national protection available): AE, AG, AL, AM, AT, AU, AZ, BA, BB, BG, BH, BR, BW, BY, BZ, CA, CH, CN, CO, CR, CU, CZ, DE, DK, DM, DO, DZ, EC, EE, EG, ES, FI, GB, GD, GE, GH, GM, GT, HN, HR, HU, ID, IL, IN, IS, JP, KE, KG, KM, KN, KP, KR, KZ, LA, LC, LK, LR, LS, LT, LU, LY, MA, MD, MG, MK, MN, MW, MX, MY, MZ, NA, NG, NI, NO, NZ, OM, PG, PH, PL, PT, RO, RS, RU, SC, SD, SE, SG, SK, SL, SM, SV, SY, TJ, TM, TN, TR, TT, TZ, UA, UG, US, UZ, VC, VN, ZA, ZM, ZW.

(25) Filing Language: English

(26) Publication Language: English

(30) Priority Data:  
0613593.3 8 July 2006 (08.07.2006) GB

(71) Applicant (for all designated States except US): **BENTLEY MOTORS LIMITED** [GB/GB]; Pym's Lane, Crewe, Cheshire CW1 3PL (GB).

(84) Designated States (unless otherwise indicated, for every kind of regional protection available): ARIPO (BW, GH, GM, KE, LS, MW, MZ, NA, SD, SL, SZ, TZ, UG, ZM, ZW), Eurasian (AM, AZ, BY, KG, KZ, MD, RU, TJ, TM), European (AT, BE, BG, CH, CY, CZ, DE, DK, EE, ES, FI,

(72) Inventor; and

(75) Inventor/Applicant (for US only): **WREN, Philip**

[Continued on next page]

(54) Title: A HOLDER FOR A VESSEL HAVING A BASE AND A STEM

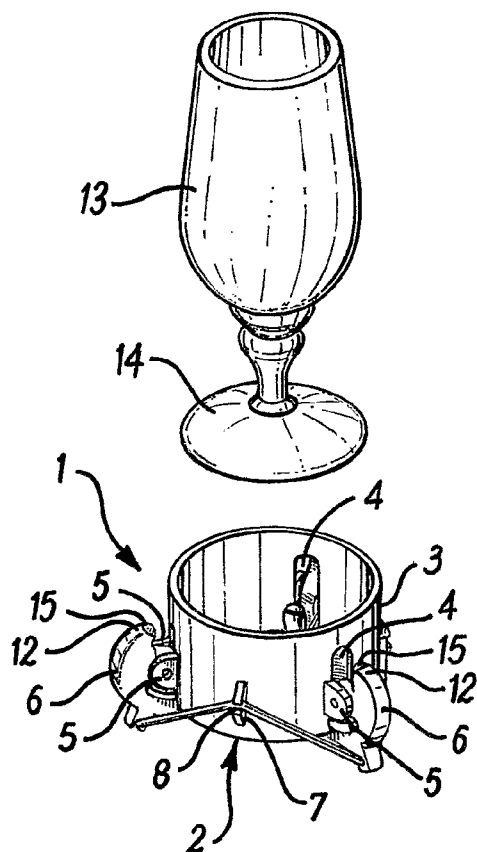

(57) Abstract: A holder for a vessel such as a glass particularly for use in a vehicle such as a motor car comprises a housing (1) having a base (2) and cylindrical wall (3). The wall (3) defines three slots (4) spaced at 120° angles with respect to the axis of the cylinder. Three cams (6) are respectively pivotally connected to projections (5) extending from the wall (3) adjacent respective slots (4). Three further spaced projections (7) extend from the wall (3) and slots (4) are formed on the cams (6) and projections (7) between which elastic bands or springs (10) extend. On introducing a glass into the holder, the cam first resists further progress of the glass into the holder. On pushing the glass down the cams (6) pivot moving from a position in which they resist movement to a position in which they assist movement until the base of the glass is held firmly by the cams (6) against the base (2) of the holder to hold the glass firmly in position. Removal of the glass is the reversal of the insertion operation.

WO 2008/007053 A2



FR, GB, GR, HU, IE, IS, IT, LT, LU, LV, MC, MT, NL, PL,  
PT, RO, SE, SI, SK, TR), OAPI (BF, BJ, CF, CG, CI, CM,  
GA, GN, GQ, GW, ML, MR, NE, SN, TD, TG).

*For two-letter codes and other abbreviations, refer to the "Guidance Notes on Codes and Abbreviations" appearing at the beginning of each regular issue of the PCT Gazette.*

**Published:**

- *without international search report and to be republished upon receipt of that report*

A HOLDER FOR A VESSEL HAVING A BASE AND A STEM

The present invention relates to a holder for a vessel having a base and a stem such as a champagne flute. The holder is particularly, but not  
5 exclusively, intended for use in a vehicle such as a motor car.

Holders of this general type are already known. One such is described and claimed in US 6 969 035 B2. In the holder described in this patent specification a vertically movable stand element is provided upon which a glass to be held sits. Movable holding-down devices engage over the base  
10 of a glass sitting on the movable stand element. A locking device locks the holding devices against movement from the holding position into the removal position when the stand element has been moved downwardly into a holding position. This is an unnecessarily complicated arrangement and it is an object of the present invention to provide a simpler arrangement.

15 According to the present invention there is provided a holder for a vessel having a base and a stem comprising a housing including a base to support a vessel, retaining means comprising one or more movable members operative in one position to urge a vessel in the holder against the base of the housing to hold the vessel and in another position to enable a vessel to  
20 be withdrawn and resilient means coacting with the retaining means to urge the or each movable member into said one position and the or each movable

member away from the said one position in dependence upon the position of a vessel in the holder.

In a preferred embodiment of the invention the or each movable member is pivotally connected to the housing. The housing advantageously defines one or more apertures to enable the or each respective member to move into and out of the housing. Preferably the or each aperture comprises a slot. Advantageously, the or each member comprises a stop to restrict movement of the member in relation to the housing. The or each member is substantially semi-circular in shape and has at least one resilient insert at the point at which it will in use bear on a vessel being held. Preferably, there are three members advantageously spaced at 120° angles with respect to the axis of the housing. Preferably, the housing is circular in cross-section. The resilient means preferably comprises an elastic band or a spring. Advantageously, the band or spring is mounted on projections formed on the external surface of the housing and on the or each member.

In order that the invention may be more clearly understood one embodiment of the invention will now be described, by way of example, with reference to the accompanying drawings, in which:-

Figure 1 is a perspective view of one form of holder showing a champagne/wine glass to be held therein displaced upwardly therefrom;

Figure 2 is a perspective view of the holder and glass of Figure 1 but

with the glass held in position in the holder, and

Figures 3a – 3c respectively show cross-sectional views of the glass and holder in three different operational positions as the glass is pushed into the holder.

5 Referring to Figure 1, the holder comprises a housing 1 having a base 2 and a cylindrical wall 3. The wall 3 defines three slots 4 extending therethrough and spaced at 120° angles with respect to the axis of the cylinder. Adjacent each slot 4 and extending externally from wall 3 is a pair of spaced projections 5. Three cams 6 are respectively pivotally connected  
10 to the three pairs of projections 5. Three further projections 7 also spaced at 120° angles with respect to the axis of the cylinder extend externally from the wall 3. Each further projection 7 is formed with a slot 8 on its lower side and each cam 6 is also formed with a slot 9 on its lower side. Disposed in those slots 8 and 9 is an elongate endless elastic band or spring 10. Each  
15 cam 6 is substantially semicircular in shape. In the position shown in Figure 1, the band or spring 10 pulls down on that part 11 of each cam 6 below the corresponding pivot 5 urging parts 12 of the cams on the other side of the pivots away from the wall 3 and the parts 11 below the pivots into slots 4.

20 Referring additionally to Figure 2, as a glass 13 is inserted into the housing 1 of the holder, the base 14 of the glass contacts parts 11 of cams

6 pushing those parts out of the corresponding slots 4, pivoting the cams about the pivots provided by pairs of projections 5 against the action of the band or spring 10. As each cam is pivoted over its corresponding dead point the force of the band or spring 10 changes from resisting movement of the  
5 cams to assisting movement. Thus parts 12 of the cams 6 are pivoted through the corresponding slots 4 pressing down on the base 14 of the glass 13 and urging the glass against the base 2 of the holder to hold the glass firmly in position in the holder. Removal of the glass is the reversal of this insertion operation. Pulling the glass 13 upwardly pivots the cams 6 so that  
10 the parts 12 are withdrawn from the slots 4 initially against the force applied by the band or spring 10 until the dead point is passed when the force on the cams reverses direction. To protect the glass, each part 12 of the corresponding cam includes a soft material, such as rubber, insert 15.

This clamping/unclamping may be seen more clearly by reference to  
15 the cross-sectional drawings of Figures 3a to 3c which show the different operational positions adopted by one of the three cams 6. Figure 3a shows the position as the glass is inserted into the holder. Prior to insertion the cam is urged by band or spring 10 in an anticlockwise direction, anticlockwise movement being limited by the abutment of a stop 16 on the  
20 cam on the base 2 of the holder. As the glass is inserted further into the holder as shown in Figure 3b, the base 14 of the glass pushes down on part

12 of the cam against the action of the band or spring 10 and until the cam passes the dead point beyond which the force of the band or spring reverses and pulls the cam down onto the base of the glass. This continues until the position shown in Figure 3c is reached when the part 12 of the cam urges  
5 the glass down onto the base 2 of the holder holding the glass firmly in position.

The housing and parts of the holder are advantageously made of synthetic plastics material. The band or spring may be made of rubber (synthetic or material) or metal.

10 It will be appreciated that the above embodiment has been described by way of example only and that many variations are possible without departing from the scope of the invention. For example, a microswitch may be provided in the holder and operated by insertion of a glass to illuminate a white LED/light disposed at the base of the holder.

CLAIMS

1. A holder for a vessel having a base and a stem comprising a housing including a base to support a vessel, retaining means comprising one  
5 or more movable members operative in one position to urge a vessel in the holder against the base of the housing to hold the vessel and in another position to enable a vessel to be withdrawn and resilient means coacting with the retaining means to urge the or each movable member into said one position and the or each movable member away  
10 from the said one position in dependence upon the position of a vessel in the holder.
2. A holder for a vessel as claimed in claim 1, in which the or each movable member is pivotally connected to the housing.
3. A holder for a vessel as claimed in claim 1 or 2, in which the housing  
15 defines one or more apertures to enable the or each respective member to move into and out of the housing.
4. A holder for a vessel as claimed in claim 3, in which the or each aperture comprises a slot.
5. A holder for a vessel as claimed in any preceding claim, in which the  
20 or each member comprises a stop to restrict movement of the member in relation to the housing.

6. A holder for a vessel as claimed in any preceding claim, in which the or each member is substantially semi-circular in shape.
7. A holder for a vessel as claimed in any preceding claim, in which the or each member comprises at least one resilient insert at the point at  
5 which it will, in use, bear against a vessel being held.
8. A holder for a vessel as claimed in any preceding claim, in which there are three members.
9. A holder for a vessel as claimed in claim 8, in which the three members are spaced at  $120^\circ$  intervals with respect to the axis of the  
10 housing.
10. A holder for a vessel as claimed in any preceding claim, in which the housing is circular in cross-section.
11. A holder for a vessel as claimed in any preceding claim, in which the resilient means comprises an elastic band.
- 15 12. A holder for a vessel as claimed in any of claims 1 to 10, in which the resilient means comprises a spring.
13. A holder for a vessel as claimed in claims 11 or 12, in which the band or spring is mounted on projections formed on the external surface of the housing and on the or each member.

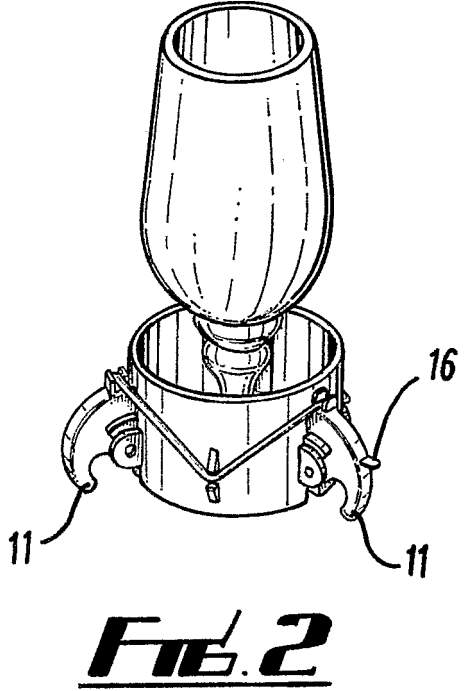
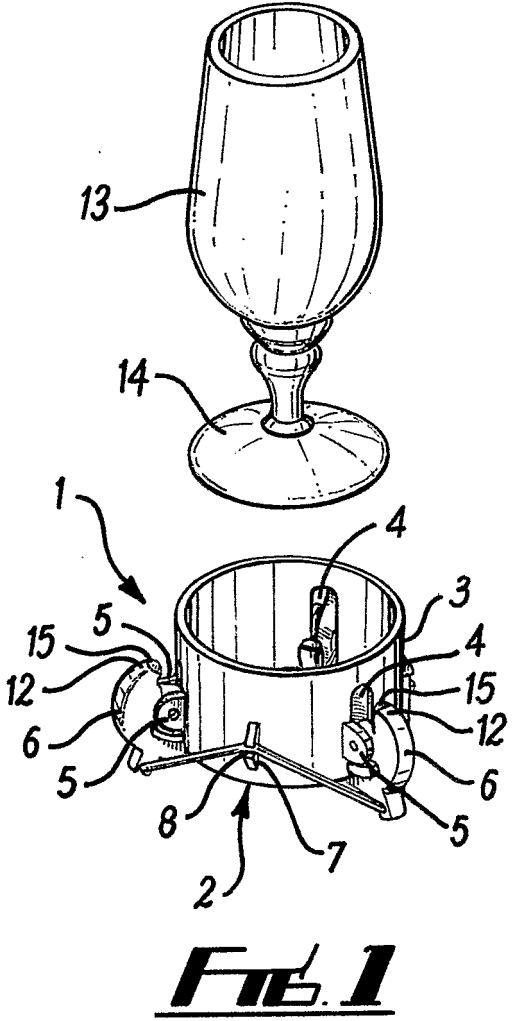

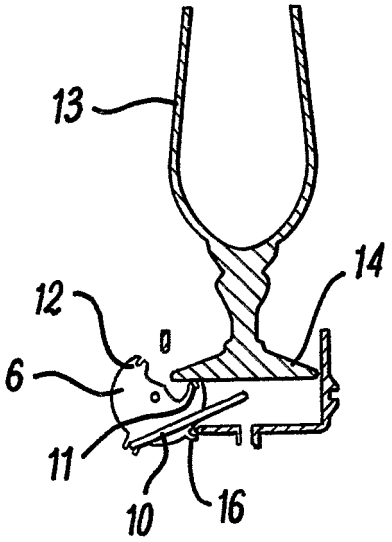

FIG. 3a

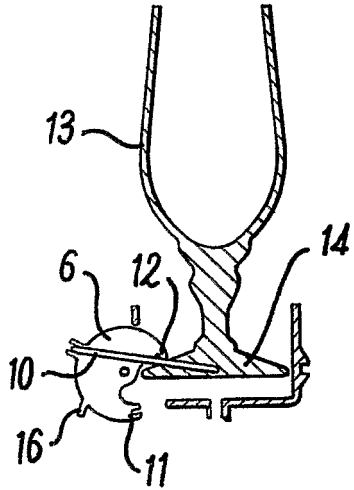

FIG. 3b

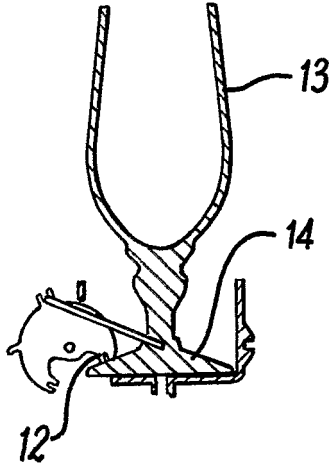

FIG. 3c