



- (51) **International Patent Classification:**  
H01J 37/32 (2006.01)
- (21) **International Application Number:**  
PCT/US2017/031275
- (22) **International Filing Date:**  
05 May 2017 (05.05.2017)
- (25) **Filing Language:** English
- (26) **Publication Language:** English
- (30) **Priority Data:**  
15/166,777 27 May 2016 (27.05.2016) US
- (71) **Applicant:** MKS INSTRUMENTS, INC. [US/US]; 2 Tech Drive, Suite 201, Andover, Massachusetts 01810 (US).
- (72) **Inventors:** KAMAREHI, Mohammad; 504 Katahdin Drive, Lexington, Massachusetts 02421 (US). HU, Chaolin; 6 Dove Lane, North Billerica, Massachusetts 01862 (US). KELLER, Olivia; 14 Boxford Road, Topsfield, Massachusetts 01983 (US).
- (74) **Agent:** MILLS, Steven M. et al.; Burns & Levinson LLP, 125 Summer Street, Boston, Massachusetts 02110 (US).

(81) **Designated States** (unless otherwise indicated, for every kind of national protection available): AE, AG, AL, AM, AO, AT, AU, AZ, BA, BB, BG, BH, BN, BR, BW, BY, BZ, CA, CH, CL, CN, CO, CR, CU, CZ, DE, DJ, DK, DM, DO, DZ, EC, EE, EG, ES, FI, GB, GD, GE, GH, GM, GT, HN, HR, HU, ID, IL, IN, IR, IS, JP, KE, KG, KH, KN, KP, KR, KW, KZ, LA, LC, LK, LR, LS, LU, LY, MA, MD, ME, MG, MK, MN, MW, MX, MY, MZ, NA, NG, NI, NO, NZ, OM, PA, PE, PG, PH, PL, PT, QA, RO, RS, RU, RW, SA, SC, SD, SE, SG, SK, SL, SM, ST, SV, SY, TH, TJ, TM, TN, TR, TT, TZ, UA, UG, US, UZ, VC, VN, ZA, ZM, ZW.

(84) **Designated States** (unless otherwise indicated, for every kind of regional protection available): ARIPO (BW, GH, GM, KE, LR, LS, MW, MZ, NA, RW, SD, SL, ST, SZ, TZ, UG, ZM, ZW), Eurasian (AM, AZ, BY, KG, KZ, RU, TJ, TM), European (AL, AT, BE, BG, CH, CY, CZ, DE, DK, EE, ES, FI, FR, GB, GR, HR, HU, IE, IS, IT, LT, LU, LV, MC, MK, MT, NL, NO, PL, PT, RO, RS, SE, SI, SK, SM, TR), OAPI (BF, BJ, CF, CG, CI, CM, GA, GN, GQ, GW, KM, ML, MR, NE, SN, TD, TG).

**Declarations under Rule 4.17:**

— as to applicant's entitlement to apply for and be granted a patent (Rule 4.17(ii))

(54) **Title:** COMPACT MICROWAVE PLASMA APPLICATOR UTILIZING CONJOINING ELECTRIC FIELDS

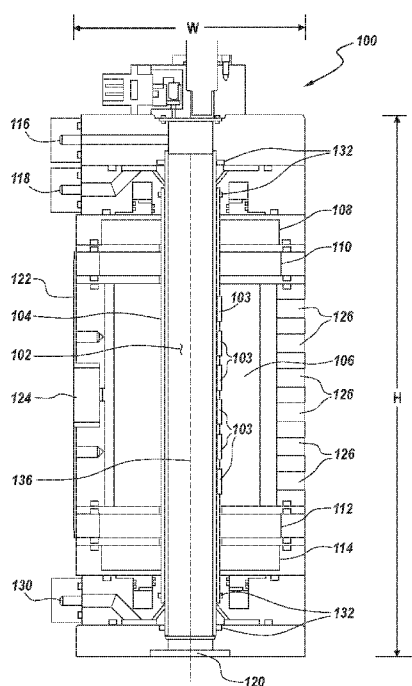

Fig. 1

(57) **Abstract:** A plasma applicator includes a plasma discharge tube and a microwave cavity at least partially surrounding a portion of the plasma discharge tube. Microwave energy is coupled to the microwave cavity via a coupling iris. At least two orthogonal dimensions of the microwave cavity are selected such that the microwave energy in the microwave cavity propagates in a transverse electric (TE) mode. Primary electric fields generated from the microwave energy combine with an evanescent electric field generated from the coupling iris, such that a combined electric field in the microwave cavity is substantially uniform along the longitudinal axis of the plasma discharge tube. A plurality of radial microwave chokes is disposed over an exterior of the plasma discharge tube. Positions of the microwave chokes are such that microwave energy propagating in the TE mode and a transverse electric magnetic (TEM) mode is attenuated.



**Published:**

— *with international search report (Art. 21(3))*

**(88) Date of publication of the international search report:**

26 July 2018 (26.07.2018)

## INTERNATIONAL SEARCH REPORT

International application No.  
PCT/US2017/031275**A. CLASSIFICATION OF SUBJECT MATTER****H01J 37/32(2006.01)i**

According to International Patent Classification (IPC) or to both national classification and IPC

**B. FIELDS SEARCHED**Minimum documentation searched (classification system followed by classification symbols)  
H01J 37/32; H05H 1/24; C23F 1/00; C23F 1/02; H05H 1/00; C23C 16/511; B23K 10/00Documentation searched other than minimum documentation to the extent that such documents are included in the fields searched  
Korean utility models and applications for utility models  
Japanese utility models and applications for utility modelsElectronic data base consulted during the international search (name of data base and, where practicable, search terms used)  
eKOMPASS(KIPO internal) & keywords: Plasma, transverse, cavity, choke, microwave**C. DOCUMENTS CONSIDERED TO BE RELEVANT**

Category*	Citation of document, with indication, where appropriate, of the relevant passages	Relevant to claim No.
Y	US 7497922 B2 (SATYENDRA KUMAR et al.) 03 March 2009 See column 3, line 26 - column 6, line 5; claim 33; and figure 1A.	1-33
Y	EP 1102521 A2 (ARCHIMEDES TECHNOLOGY GROUP, INC.) 23 May 2001 See paragraphs [0018]-[0029]; and figures 1-2.	1-33
Y	US 2002-0112819 A1 (MOHAMMAD KAMAREHI et al.) 22 August 2002 See paragraphs [0070]-[0081]; and figures 1, 12.	8-11, 14-17, 23-33
A	US 2014-0290860 A1 (TOKYO ELECTRON LIMITED) 02 October 2014 See paragraphs [0050]-[0077]; and figures 1-4.	1-33
A	US 2004-0182834 A1 (MOHAMMAD KAMAREHI) 23 September 2004 See paragraphs [0024]-[0035]; and figures 1-3.	1-33

 Further documents are listed in the continuation of Box C. See patent family annex.

\* Special categories of cited documents:

"A" document defining the general state of the art which is not considered to be of particular relevance

"E" earlier application or patent but published on or after the international filing date

"L" document which may throw doubts on priority claim(s) or which is cited to establish the publication date of another citation or other special reason (as specified)

"O" document referring to an oral disclosure, use, exhibition or other means

"P" document published prior to the international filing date but later than the priority date claimed

"T" later document published after the international filing date or priority date and not in conflict with the application but cited to understand the principle or theory underlying the invention

"X" document of particular relevance; the claimed invention cannot be considered novel or cannot be considered to involve an inventive step when the document is taken alone

"Y" document of particular relevance; the claimed invention cannot be considered to involve an inventive step when the document is combined with one or more other such documents, such combination being obvious to a person skilled in the art

"&amp;" document member of the same patent family

Date of the actual completion of the international search

09 August 2017 (09.08.2017)

Date of mailing of the international search report

**09 August 2017 (09.08.2017)**

Name and mailing address of the ISA/KR

International Application Division  
Korean Intellectual Property Office  
189 Cheongsa-ro, Seo-gu, Daejeon, 35208, Republic of Korea

Facsimile No. +82-42-481-8578

Authorized officer

AHN, Jeong Hwan

Telephone No. +82-42-481-8633



**INTERNATIONAL SEARCH REPORT**

Information on patent family members

International application No.

**PCT/US2017/031275**

Patent document cited in search report	Publication date	Patent family member(s)	Publication date
US 7497922 B2	03/03/2009	AU 2003-228880 A1	11/11/2003
		AU 2003-228881 A1	11/11/2003
		AU 2003-228882 A1	11/11/2003
		AU 2003-230264 A1	11/11/2003
		AU 2003-230265 A1	11/11/2003
		AU 2003-230266 A1	11/11/2003
		AU 2003-230267 A1	11/11/2003
		AU 2003-232065 A1	11/11/2003
		AU 2003-234474 A1	11/11/2003
		AU 2003-234475 A1	11/11/2003
		AU 2003-234476 A1	11/11/2003
		AU 2003-234477 A1	11/11/2003
		AU 2003-234478 A1	11/11/2003
		AU 2003-234479 A1	11/11/2003
		AU 2003-234499 A1	11/11/2003
		AU 2003-234500 A1	11/11/2003
		AU 2003-234501 A1	11/11/2003
		AU 2003-245263 A1	11/11/2003
		AU 2003-245264 A1	11/11/2003
		AU 2003-251665 A1	23/02/2004
		AU 2003-267104 A1	11/11/2003
		AU 2003-267860 A1	11/11/2003
		AU 2003-267863 A1	11/11/2003
		AU 2003-297636 A1	23/06/2004
		CA 2485195 A1	20/11/2003
		CN 100336156 C	05/09/2007
		CN 100338976 C	19/09/2007
		CN 100425106 C	08/10/2008
		CN 100436763 C	26/11/2008
		CN 100441732 C	10/12/2008
		CN 100447289 C	31/12/2008
		CN 100455144 C	21/01/2009
		CN 100460128 C	11/02/2009
		CN 101076221 A	21/11/2007
		CN 101076221 B	31/08/2011
		CN 1302843 C	07/03/2007
		CN 1304103 C	14/03/2007
		CN 1324114 C	04/07/2007
		CN 1324931 C	04/07/2007
		CN 1652889 C	10/08/2005
		CN 1653204 A	10/08/2005
		CN 1653205 A	10/08/2005
		CN 1653205 C	10/12/2008
		CN 1653248 A	10/08/2005
		CN 1653867 C	10/08/2005
		CN 1653868 C	10/08/2005
		CN 1653869 A	10/08/2005
CN 1653869 C	08/10/2008		
CN 1653870 C	10/08/2005		

**INTERNATIONAL SEARCH REPORT**

Information on patent family members

International application No.

**PCT/US2017/031275**

Patent document cited in search report	Publication date	Patent family member(s)	Publication date
		CN 1750900 A	22/03/2006
		EP 1501631 A1	02/02/2005
		EP 1501632 A1	02/02/2005
		EP 1501649 A1	02/02/2005
		EP 1501911 A1	02/02/2005
		EP 1501959 A1	02/02/2005
		EP 1502012 A1	02/02/2005
		EP 1502274 A1	02/02/2005
		EP 1502287 A2	02/02/2005
		EP 1502480 A1	02/02/2005
		EP 1502486 A1	02/02/2005
		EP 1502486 B1	30/11/2011
		EP 1502487 A1	02/02/2005
		EP 1502488 A1	02/02/2005
		EP 1502489 A1	02/02/2005
		EP 1502489 B1	23/10/2013
		EP 1502490 A1	02/02/2005
		EP 1504464 A2	09/02/2005
		EP 1579023 A2	28/09/2005
		EP 1579023 A3	09/11/2005
		JP 2005-524799 A	18/08/2005
		JP 2005-524962 A	18/08/2005
		JP 2005-524963 A	18/08/2005
		JP 2005-525234 A	25/08/2005
		JP 2005-526359 A	02/09/2005
		KR 10-1015744 B1	22/02/2011
		KR 10-2005-0025173 A	11/03/2005
		KR 10-2005-0026387 A	15/03/2005
		TW 200417292 A	01/09/2004
		TW I334319 A	01/12/2010
		TW I334319 B	01/12/2010
		US 2004-0001295 A1	01/01/2004
		US 2004-0004062 A1	08/01/2004
		US 2004-0107796 A1	10/06/2004
		US 2004-0118816 A1	24/06/2004
		US 2005-0061446 A1	24/03/2005
		US 2005-0233091 A1	20/10/2005
		US 2005-0253529 A1	17/11/2005
		US 2005-0271829 A1	08/12/2005
		US 2006-0057016 A1	16/03/2006
		US 2006-0062930 A1	23/03/2006
		US 2006-0063361 A1	23/03/2006
		US 2006-0078675 A1	13/04/2006
		US 2006-0081567 A1	20/04/2006
		US 2006-0124613 A1	15/06/2006
		US 2006-0162818 A1	27/07/2006
		US 2006-0233682 A1	19/10/2006
		US 2006-0237400 A1	26/10/2006
		US 2006-0249367 A1	09/11/2006
		US 2007-0164680 A1	19/07/2007

## INTERNATIONAL SEARCH REPORT

Information on patent family members

International application No.

PCT/US2017/031275

Patent document cited in search report	Publication date	Patent family member(s)	Publication date
		US 6870124 B2	22/03/2005
		US 7132621 B2	07/11/2006
		US 7189940 B2	13/03/2007
		US 7227097 B2	05/06/2007
		US 7309843 B2	18/12/2007
		US 7432470 B2	07/10/2008
		US 7445817 B2	04/11/2008
		US 7465362 B2	16/12/2008
		US 7494904 B2	24/02/2009
		US 7498066 B2	03/03/2009
		US 7560657 B2	14/07/2009
		US 7592564 B2	22/09/2009
		US 7608798 B2	27/10/2009
		US 7638727 B2	29/12/2009
		WO 03-095058 A2	20/11/2003
		WO 03-095089 A1	20/11/2003
		WO 03-095090 A1	20/11/2003
		WO 03-095130 A1	20/11/2003
		WO 03-095591 A1	20/11/2003
		WO 03-095699 A1	20/11/2003
		WO 03-095807 A1	20/11/2003
		WO 03-096369 A1	20/11/2003
		WO 03-096370 A1	20/11/2003
		WO 03-096380 A2	20/11/2003
		WO 03-096381 A2	20/11/2003
		WO 03-096382 A2	20/11/2003
		WO 03-096383 A2	20/11/2003
		WO 03-096747 A2	20/11/2003
		WO 03-096749 A1	20/11/2003
		WO 03-096766 A1	20/11/2003
		WO 03-096768 A1	20/11/2003
		WO 03-096770 A1	20/11/2003
		WO 03-096771 A1	20/11/2003
		WO 03-096772 A1	20/11/2003
		WO 03-096773 A1	20/11/2003
		WO 03-096774 A1	20/11/2003
		WO 2003-095058 A3	29/04/2004
		WO 2003-096380 A3	08/07/2004
		WO 2003-096381 A3	08/07/2004
		WO 2003-096382 A3	15/07/2004
		WO 2003-096383 A3	22/07/2004
		WO 2003-096747 A3	19/02/2004
		WO 2004-013319 A2	12/02/2004
		WO 2004-013319 A3	25/03/2004
		WO 2004-050939 A2	17/06/2004
		WO 2004-050939 A3	22/09/2005
EP 1102521 A2	23/05/2001	EP 1102521 A3	16/04/2003
		JP 2001-176695 A	29/06/2001
		US 6303007 B1	16/10/2001

**INTERNATIONAL SEARCH REPORT**

Information on patent family members

International application No.

**PCT/US2017/031275**

Patent document cited in search report	Publication date	Patent family member(s)	Publication date		
US 2002-0112819 A1	22/08/2002	AU 4081500 A	14/11/2000		
		EP 1177112 A1	06/02/2002		
		EP 1177112 A4	05/03/2008		
		EP 1177112 B1	01/06/2011		
		JP 2002-541672 A	03/12/2002		
		JP 4714347 B2	29/06/2011		
		US 2002-0007912 A1	24/01/2002		
		US 2002-0011214 A1	31/01/2002		
		US 2002-0011310 A1	31/01/2002		
		US 6263830 B1	24/07/2001		
		US 6352050 B2	05/03/2002		
		US 6412438 B2	02/07/2002		
		US 6439155 B1	27/08/2002		
		WO 00-61384 A1	19/10/2000		
		US 2014-0290860 A1	02/10/2014	CN 101647101 A	10/02/2010
				CN 101647101 B	20/06/2012
JP 2008-251660 A	16/10/2008				
JP 2008-251674 A	16/10/2008				
JP 5438260 B2	12/03/2014				
JP 5522887 B2	18/06/2014				
KR 10-1119627 B1	07/03/2012				
KR 10-1173268 B1	10/08/2012				
KR 10-1333112 B1	26/11/2013				
KR 10-2010-0003293 A	07/01/2010				
KR 10-2011-0089208 A	04/08/2011				
KR 10-2012-0034117 A	09/04/2012				
TW 200845199 A	16/11/2008				
TW I386997 B	21/02/2013				
US 2010-0101728 A1	29/04/2010				
WO 2008-123605 A1	16/10/2008				
US 2004-0182834 A1	23/09/2004	JP 2006-516806 A	06/07/2006		
		TW 200415961 A	16/08/2004		
		US 7183514 B2	27/02/2007		
		WO 2004-068559 A2	12/08/2004		
		WO 2004-068559 A3	11/11/2004		