

(19) World Intellectual Property Organization  
International Bureau



(43) International Publication Date  
24 December 2008 (24.12.2008)

PCT

(10) International Publication Number  
**WO 2008/155608 A2**

(51) International Patent Classification:  
*G09F 9/37* (2006.01)

(21) International Application Number:  
PCT/IB2007/052315

(22) International Filing Date: 18 June 2007 (18.06.2007)

(25) Filing Language: English

(26) Publication Language: English

(71) Applicant (for all designated States except US): **MPOT PTE LTD** [SG/SG]; 30 Kallang Place, #07-07, Singapore 339159 (SG).

(71) Applicant and

(72) Inventor: **LEE, Song** [SG/SG]; 2 Surin Lane, Singapore 535543 (SG).

(74) Common Representative: **LEE, Song**; 2 Surin Lane, Singapore 535543 (SG).

(81) Designated States (unless otherwise indicated, for every kind of national protection available): AE, AG, AL, AM, AT, AU, AZ, BA, BB, BG, BH, BR, BW, BY, BZ, CA, CH,

CN, CO, CR, CU, CZ, DE, DK, DM, DO, DZ, EC, EE, EG, ES, FI, GB, GD, GE, GH, GM, GT, HN, HR, HU, ID, IL, IN, IS, JP, KE, KG, KM, KN, KP, KR, KZ, LA, LC, LK, LR, LS, LT, LU, LY, MA, MD, ME, MG, MK, MN, MW, MX, MY, MZ, NA, NG, NI, NO, NZ, OM, PG, PH, PL, PT, RO, RS, RU, SC, SD, SE, SG, SK, SL, SM, SV, SY, TJ, TM, TN, TR, TT, TZ, UA, UG, US, UZ, VC, VN, ZA, ZM, ZW.

(84) Designated States (unless otherwise indicated, for every kind of regional protection available): ARIPO (BW, GH, GM, KE, LS, MW, MZ, NA, SD, SL, SZ, TZ, UG, ZM, ZW), Eurasian (AM, AZ, BY, KG, KZ, MD, RU, TJ, TM), European (AT, BE, BG, CH, CY, CZ, DE, DK, EE, ES, FI, FR, GB, GR, HU, IE, IS, IT, LT, LU, LV, MC, MT, NL, PL, PT, RO, SE, SI, SK, TR), OAPI (BF, BJ, CF, CG, CI, CM, GA, GN, GQ, GW, ML, MR, NE, SN, TD, TG).

**Declarations under Rule 4.17:**

- as to applicant's entitlement to apply for and be granted a patent (Rule 4.17(ii))
- of inventorship (Rule 4.17(iv))

**Published:**

- without international search report and to be republished upon receipt of that report



WO 2008/155608 A2

(54) Title: DISPLAY NUCLEUS OF MAGNETIC DISPLAY ELEMENT

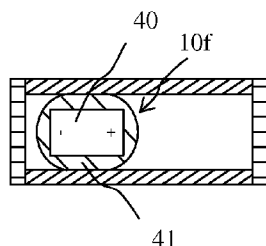

Fig. 6

(57) Abstract: A display nucleus of a magnetic display element is disclosed. The display nucleus has a surface that is generally not perpendicular to the direction of the display element. This allows the display element to be shorter. The display nucleus is stable at various depth positions within the tube of the display element even though the transverse cross-sections of the display nucleus and display element are not necessarily the same. This is because the depth position stability of the display nucleus is provided either by a thin coating that can stick and re-stick to the tube of the display element or a compressible body that can fit into the display element. This reduces the rejection rate of display elements and display panels.

## Description

### DISPLAY NUCLEUS OF MAGNETIC DISPLAY ELEMENT

#### Technical Field

- [1] The present invention relates to the display nucleus of a display element. More specifically, although of course not solely limited thereto, this invention relates to the display nucleus of a magnetic display element.

#### Background Art

- [2] Magnetic display panels are often made up of many magnetic display elements or cells arranged in a matrix of rows and columns. Each display element represents a 'dot' and together, the 'dots' make up an image. Each dot can represent either of two colors, such as black and white, or shades of colors, such as from white to gray to black.
- [3] One such example of a display element comprises a long black display element tube with a white display nucleus which fits within it. The display nucleus is shaped like a rod with the ends flat and the sides in good contact with the display element tube. The display nucleus can be made of soft magnetic material like iron. A magnetic pen can be used to attract the display nucleus forward towards the front opening of the display element tube. A magnetic eraser can be used at the back of the display element and attract the display nucleus backward towards the back of the opening of the display element tube. The display nucleus can remain stable in various depth positions within the display element tube because the contact forces between the display nucleus and the display element tube can overcome destabilizing forces like the self weight of the display nucleus.
- [4] When the white display nucleus is at the front end of the display element tube, the display nucleus can be seen clearly. The 'dot' is bright (white color). When the white display nucleus is at the back end of the display element tube, the white display nucleus cannot be seen clearly. Most of the light entering the display element tube is absorbed by the black display element tube before it can be reflected back out of the display element tube. As such, the display element tube appears dark (black). The display element can display various degree of brightness (grayscale) according to the depth position of the display nucleus within the display element tube.

#### Disclosure of Invention

#### Technical Problem

- [5] The first problem with the current display element is that the display element requires a relatively long display element tube to be able to produce a good contrast between bright (color) and dark (black) displays. The length of the display element tube may be up to eight times the diameter of the opening of the display element. For such a long

display element tube, an extremely strong and big magnet needs to be used to be able to attract the display nucleus forward when the display nucleus is at the other end of the display element tube. Also, such a long display element length would render such a display element not suitable in areas where there is space constraint.

[6] One way which is being used to reduce the length of the display element tube is to introduce a light reducing film at the opening of the display element tube. When less light enters and leaves the display element tube through the light reducing film, the length of the black display element tube can be shorter for it to display black when the white display nucleus is at the other end of the display element tube. The drawback of such a solution is that it makes the display element reflect less light, even for the case when the white display nucleus is at the front end of the display element tube. When the display element becomes darker and less bright, the image collectively produced by the many display elements is dull or dark.

[7] The second problem relates to the contact between the display element tube and the display nucleus. In order to achieve the desired contact forces between the display element tube and the display nucleus for good stability of the depth position of the display nucleus within the display element tube, both of them need to have a good fit. When the fit is not good, the display nucleus might not be able to maintain its depth position within the display element tube and as a result, the display element cannot function properly. This increases the rejection rate of the display element and display panel. Furthermore, even when there is a good fit at a certain temperature, the good fit might be affected by temperature changes as the volume of materials depend on their temperatures.

[8] The third problem is that the display nucleus is made of soft magnetic material and is attracted by both south-pole and north-pole of a magnet. Hence if drawing is by using a magnet to attract the display nucleus forward, then erasing is by using a magnet to attract the display nucleus backward from behind the display element tube. This makes erasing of an image consisting of a matrix of display elements non-elegant and non-intuitive whereby drawing is from the front and erasing is from the back.

### **Technical Solution**

[9] The first problem arises because the surface of the white display nucleus is flat and perpendicular to the direction of the tube. As such, light rays that come in parallel to the tube is also reflected back out without hitting or being absorbed by the black wall of the display element tube. Consequently, the length of the display element tube needs to be long. By having a curved surface or a surface for the display nucleus that is not perpendicular to the direction of the display element tube, more light rays are reflected to the wall of the display element tube when the display nucleus is further down the display element tube. Consequently, the length of the display element tube can be

shorter.

- [10] The second problem can be resolved by avoiding the need for a good fit between the display nucleus and the display element tube. By using a smaller nucleus, the display nucleus can easily go into the display element tube. By coating the display nucleus with a sticky adhesive or a liquid, the display nucleus will have the ability to maintain its depth position within the tube through adhesion or surface tension forces.
- [11] Another way is to design the display nucleus in such a way that its cross-section size can be easily varied to fit the size of the tube. One such way is to have the whole nucleus made of compressible material with magnetic particles added. Another way is to have a layer of non-magnetic compressible material around the incompressible soft magnetic material. Yet another design is one which is similar to the design of a pipe cleaner. It can be made up of two or more wires twisted together with fibers.
- [12] The third problem can be resolved by using magnetized permanent magnetic material for the display nucleus. A magnetized permanent magnetic material has both a north-pole and a south-pole. It can be attracted or repelled by a magnetic pen or magnetic eraser from the front of the display element tube according to the theory of magnetism whereby unlike poles attract and like poles repel.
- [13] It should be noted that by just having a magnetized permanent magnetic material for the display nucleus is not sufficient to make an effective display element. The magnetic field generated by neighboring display elements will have strong destabilizing effects on the depth position of the display nucleus within the display element tube. This solution has to be coupled with solution two, which provides effective ways to stabilize the depth position of the display nucleus against the destabilizing forces created by gravity and neighboring display elements' magnetic field.

### **Advantageous Effects**

- [14] The present invention allows for the display elements to be shorter and hence be used in areas where space constraint is an issue. The display panel will also be lighter and use less material as a result being shorter. Without a light reducing film at the opening of the display element tube, the display element can have brighter displays.
- [15] Secondly, the difficulty in providing a good fit between the display nucleus and the display element tube in order to make the display nucleus stable is eliminated. As such, the rejection rate during manufacturing of the display elements will be reduced.
- [16] Thirdly, with the stability of the depth position of the display nucleus within the display element tube achieved, the use of magnetized permanent magnetic material for the display nucleus will allow for the drawing or erasing of images on a magnetic display panel from the front.

### Description of Drawings

[17] The accompanying drawings are solely for purposes of illustrating the concepts of the invention and are not drawn to scale. The embodiments shown in the accompanying drawings, and described in the accompanying detailed description, are used as illustrative embodiments and should not be construed as the only manner of practicing the invention. Also, the same reference numerals, possibly supplemented with reference characters where appropriate, have been used to identify similar parts. The '+' and '-' signs used in the drawings refer to the magnetic north and south poles respectively. These and other objects and features of this invention will be clear and apparent to those skilled in the art upon reading the detailed description together with the drawings, wherein:

[18] FIG. 1 is a longitudinal cross-sectional view of a current magnetic display element with a display nucleus that has a flat display surface perpendicular to the direction of the display element;

[19] FIG. 2 is a longitudinal cross-sectional view of a shorter display element with a display nucleus that has a curved display surface;

[20] FIG. 3 shows other possible display surfaces of the display nucleus;

[21] FIG. 4 shows the longitudinal cross-sectional view of the display element with a display nucleus with additional coating;

[22] FIG. 5 shows the longitudinal cross-sectional view of display elements with various display nuclei that can change size;

[23] FIG. 6 shows the longitudinal cross-sectional view of a display element with a magnetized permanent magnetic nucleus;

[24] FIG. 7 shows the various transverse cross-sectional shapes of display nuclei.

### Best Mode

[25] Referring to FIG. 1, it shows a prior art of a longitudinal cross-sectional view of a magnetic display element 1. The magnetic display element 1 comprises a display element tube 2, front screen 3, back screen 4, and a display nucleus 10a. Light rays 6 enter the display element 1 through the front screen 3 and are reflected by the front display surface 11a of the display nucleus 10a. The reflected rays 7a are reflected back out the front screen 3 to the viewer. Typically, the display element tube 2 is black in color so as to absorb light, while the display nucleus 10a is of another color, such as white or any other colors to give the display element 1 the color required. A long display element tube 2 of up to eight times the diameter of the tube's opening is required for it to be able to achieve a good contrast of bright (color) and dark (black) colors effectively. This is because light rays 6 that are parallel to the direction of the display element tube 2 are reflected back in parallel by the flat display surface 11a of

the display nucleus **10a**.

[26] Referring to FIG. 2, this invention shows a display nucleus **10b** having a curved front display surface **11b**. Light rays **6** parallel to the direction of the display element tube **2** enters the display element and are reflected by the curved display surface **11b** according to the theory of light reflection. The reflected light rays **7b** are non-parallel and less light returns to the viewer through the front screen **3**. Hence, a shorter display element tube **2** is required for the display element **1** to have the ability to display two colors effectively. The distance **12** between the display surface **11b** and the front screen **3** can be reduced to about two times the diameter of the opening of the display element tube **2**.

[27] If the display element **1** is required to be able to be viewed from either ends, then the surfaces facing the front screen **3** and back screen **4** can be of the same shape. If the display element **1** is required to be able to be viewed from only one end, then the back surface of the display nucleus is not critical, and can be flat or other shapes.

[28] Referring to FIG. 3, many other front surface shapes of the display nucleus are possible. It could be a single slope as in **11c**, double sided slopes as in **11d**, multiple slopes as in **11e**, slight curve as in **11f**, or other shapes. As the surfaces **11** are not flat and perpendicular to the direction of the display element tube **2**, the display element tube **2** can be shorter.

[29] Referring to FIG. 4, the display nucleus **10b** has an additional coating **13** which allows it to stick to the display element tube **2**. This coating **12** can be oil or grease, which allows the display nucleus **10b** to stick onto the display element tube **2** or the front screen **3** or the back screen **4** in a stable position. When the display nucleus **10b** is subjected to additional force, such as an attractive magnetic force due to an external magnet, the display nucleus can move forward. It can remain stable in its new position after the removal of the external magnetic field as the oil or grease provides that required adhesion or stabilizing force. Another type of coating is an adhesive which can stick and re-stick many times. Such coatings are often tacky in nature. The coating described here are only examples and other coatings are possible as long as they provide the required functions. The display nucleus **10b** can be smaller than the internal size of the display element tube as the coating **13** provides the stabilizing forces required to maintain its depth position, instead of that provide by a good fit. It can be seen in FIG. 4 that there is a gap **14** between the display nucleus **10b** and the display element tube **2**. The FIG. 4 is not to scale and has the gap **14** and the coating **13** enlarged to provide a better understanding. Normally, the coating **13** is very thin and the gap **14** can be smaller. No gap is also possible. However, the ability for the display nucleus **10b** to function with or without gap **14** means that an exact fit is not required and this makes manufacturing easier and reduces the defect or rejection rate of display

elements 1.

[30] Referring to FIG. 5, the display nucleuses **10c**, **10d**, and **10e** are larger than the transverse internal cross-section of the display element tube **2**. However they can be inserted into the display element tube **2** because their sizes can become smaller. For the display nucleus **10c**, it has an incompressible core **20** such as iron and a compressible outer layer **21**. The compressible layer **21** reduces in size and allows the display nucleus to fit into the display element tube **2**. The compressed layer **20** pushes against the walls of the display element tube **2** and thereby stabilizes the depth position of the display nucleus within the display element tube **2**. The display nucleus **10c** can still move forward or backward when additional forces act on it. For nucleus **10d**, the whole nucleus is compressible, such as expanded polystyrene or polyurethane with non-permanent or permanent magnetic particles added. Again, it is compressed in order for it to fit into the display element tube **2**. For nucleus **10e**, it has a central body made up of a twisted pair of wires **30** holding fibers **31** in place. It is similar to the pipe cleaners in design. The fibers **31** can bend and cause the transverse cross-section to reduce in size, allowing the display nucleus **10e** to fit into the display element tube **2**. The fibers provide the required contact forces to stabilize the depth position of the display nucleus **10e** inside the display element tube **2**. Although described here are a few ways to stabilize the depth position of the display nucleus **10** within the display element tube **2**, they are not exhaustive and for those skilled in the art will find many other obvious ways of keeping the display nucleus stable.

[31] Current magnetic display elements commonly do not have magnetized magnetic nucleuses. For those that have, their magnetized magnetic nucleuses do not have depth position stability because they are influenced by the magnetic field from their neighboring magnetized magnetic nucleuses. In this invention, it is possible to achieve depth position stability for the display nucleus, and as such it is possible to have a magnetized magnetic display nucleus. Referring to FIG. 6, the display nucleus **10f** has a magnetized magnetic core **40** and a compressible layer **41**. The magnetic core **40** allows it to be attracted to or repelled by an external magnetic force, depending on the polarity of the external magnetic field. The external force can make the display nucleus **10f** move forward if it generates an attractive magnetic force, and make the display nucleus **10f** move backward if it generates a repulsive magnetic force. The compressible layer **41** provides the stabilizing force to keep the display nucleus in a stable depth position when the external magnetic field is removed.

[32] Referring to FIG. 7, it shows various transverse cross-sectional shapes of the display nucleuses **10**. The features of the invented display nucleus in reducing the length of the display element tube and achieving depth position stability of it within the display element tube can work with such transverse cross-sectional shapes or other shapes.

**Industrial Applicability**

- [33] The display nucleus is useful to display elements. It allows shorter display elements to be made and allow display elements to react accordingly to the polarities of magnetic pens or magnetic erasers, allowing images to be drawn and erased from the front. The display nucleus also reduces the failure or rejection rate of display elements and display panels.
- [34] While the present invention has been explained by reference to the preferred embodiments described above, it will be appreciated that the embodiments are only illustrated as examples to assist understanding of the present invention and are not meant to be restrictive on its scope. In particular, the scope, ambit and spirit of this invention are meant to include the general principles of the invention as inferred or exemplified by the embodiments described above. More particularly, variations or modifications which are obvious or trivial to persons skilled in the art, as well as improvements made on the basis of the present invention, should be considered as falling within the scope and boundary of the present invention.
- [35] Furthermore, while the present invention has been explained by reference to a display nucleus for a magnetic display element, it should be appreciated that the invention can apply, whether with or without modifications, to other types of display elements without loss of generality.

## Claims

- [1] What is claimed is:
1. A display nucleus of a display nucleus depth dependant display element comprising:  
a body with a light-reflecting surface facing the opening of said display element, wherein said surface is generally not perpendicular to the direction of the display element.
  - [2] 2. The display nucleus of claim 1, wherein said surface is curved.
  - [3] 3. The display nucleus of claim 1, wherein said surface is slanted or sloped.
  - [4] 4. A display nucleus of a display nucleus depth dependant display element comprising:  
a body with a light-reflecting surface facing the opening of said display element; said body further comprising a thinly coated substance which allows said body to stick, and if detached to stick again, to the internal walls of the display element.
  - [5] 5. The display nucleus of claim 4, wherein said thinly coated substance is oil or grease.
  - [6] 6. The display nucleus of claim 4, wherein said thinly coated substance is an able to re-stick adhesive.
  - [7] 7. A display nucleus of a display nucleus depth dependant display element comprising:  
a body with a light-reflecting surface facing the opening of said display element; wherein said body whose transverse cross-sectional size can be increased or decreased so as to fit into said display element.
  - [8] 8. The display nucleus of claim 7, wherein said body is made of a compressible material.
  - [9] 9. The display nucleus of claim 8, wherein said body has magnetic material.
  - [10] 10. The display nucleus of claim 7, wherein said body is made of a central incompressible core and an out layer of compressible material.
  - [11] 11. The display nucleus of claim 10, wherein said central incompressible core is permanently magnetized material.
  - [12] 12. The display nucleus of claim 7, wherein said body is made of twisted metal wires holding fibers together.

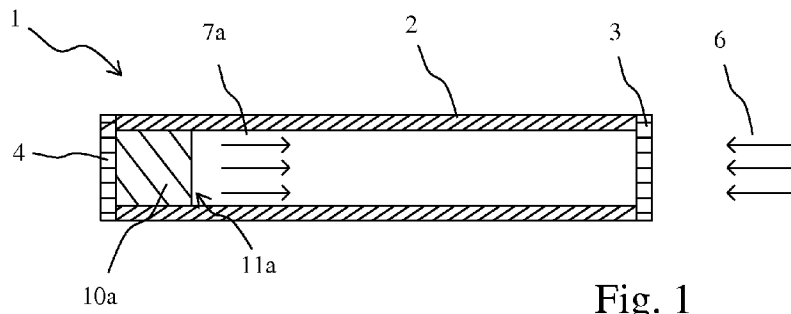

Fig. 1  
Prior Art

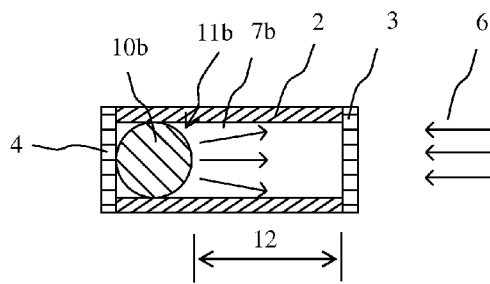

Fig. 2

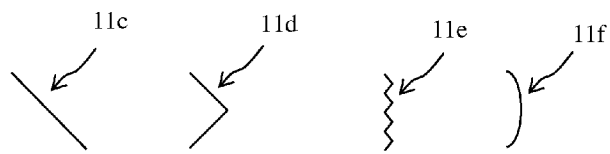

Fig. 3

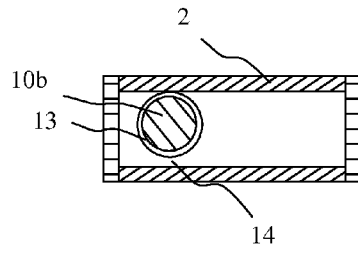

Fig. 4

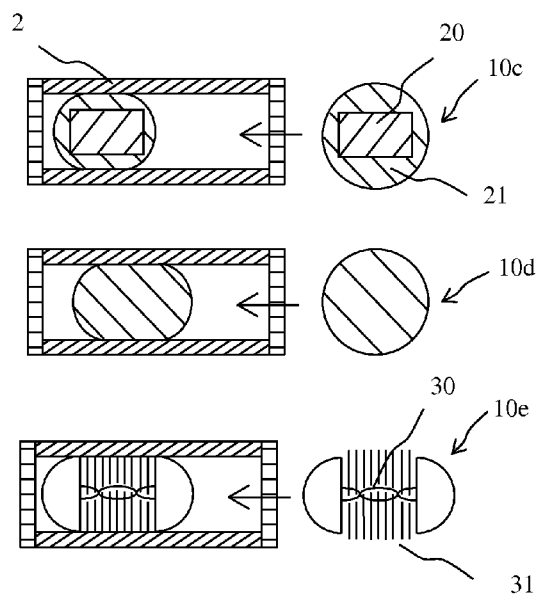

Fig. 5

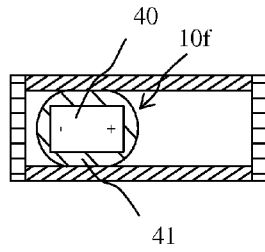

Fig. 6

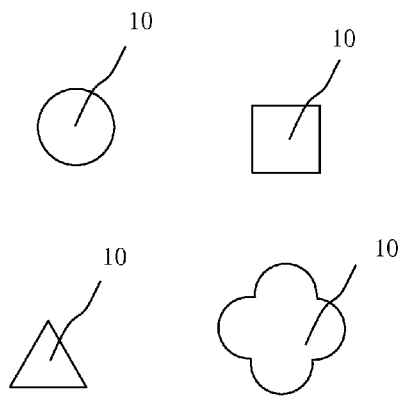

Fig. 7