

Nov. 22, 1966

J. E. NOLAN

3,286,970

BATHLIFT

Filed March 23, 1964

3 Sheets-Sheet 1

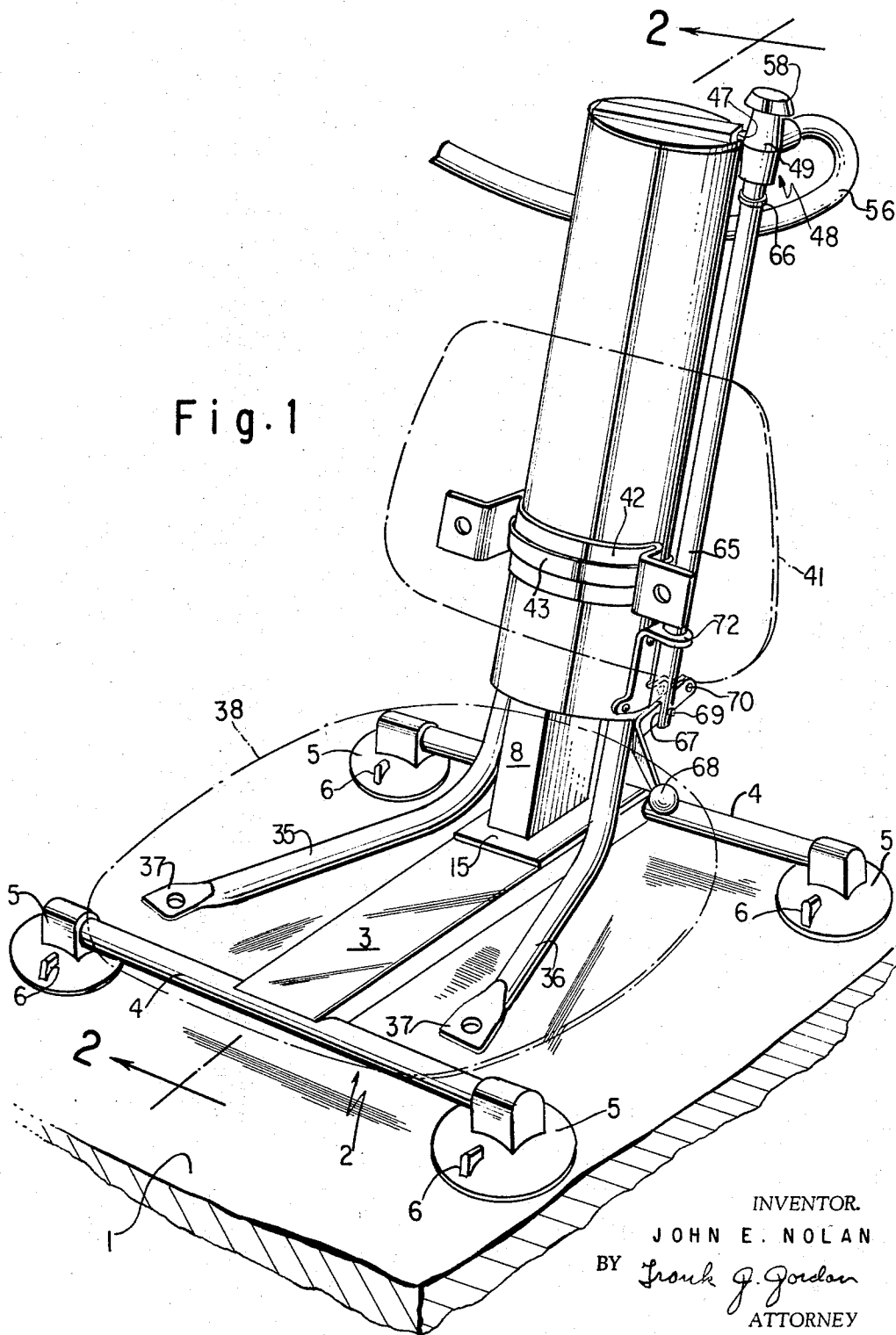

INVENTOR.

JOHN E. NOLAN

BY *Frank J. Jordan*  
ATTORNEY



Nov. 22, 1966

J. E. NOLAN

3,286,970

BATHLIFT

Filed March 23, 1964

5 Sheets-Sheet 5

Fig. 4

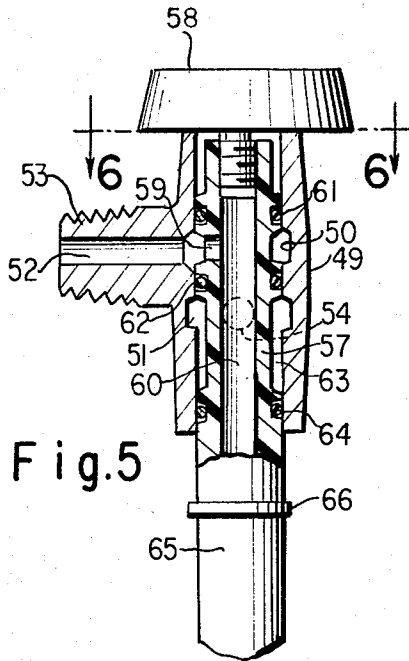
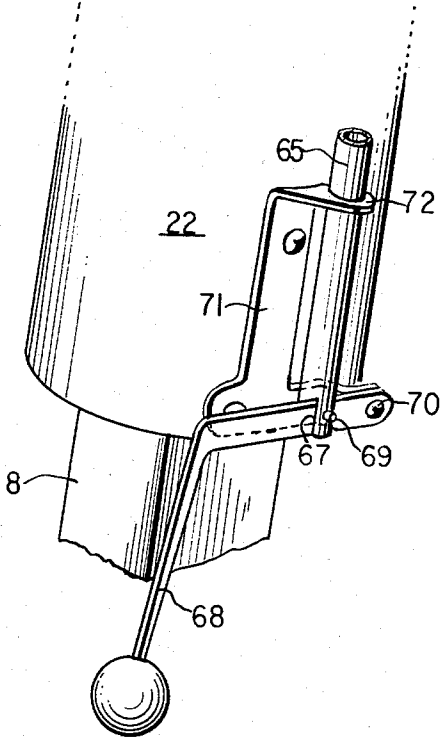

Fig. 5

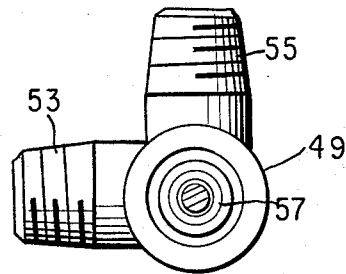

Fig. 6

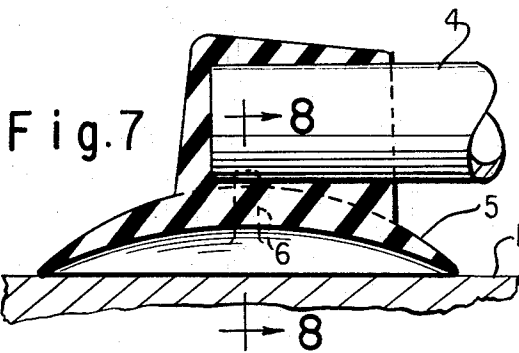

Fig. 7



Fig. 8

INVENTOR.  
JOHN E. NOLAN  
BY *Frank J. Jordan*  
ATTORNEY

1

3,286,970  
BATHLIFT

John E. Nolan, Jeffersonton, Ky., assignor to American Radiator & Standard Sanitary Corporation, New York, N.Y., a corporation of Delaware

Filed Mar. 23, 1964, Ser. No. 353,839  
4 Claims. (Cl. 248-404)

This invention relates to new and useful improvements in a lifting or hoisting apparatus and more particularly to a fluid actuated device for lifting a person in and out of a bathtub or the like. The device may be used for lowering and raising handicapped or elderly people either unassisted or assisted by an attendant as they enter and leave a bathtub.

Due to physical disabilities of various types, it is often difficult or impossible for handicapped people to enter and leave a bathtub or other similar facilities unaided. Accordingly, it is an object of this invention to provide a lifting device which is of simple and sturdy construction and which may be operated from a domestic water supply and be controlled by either the user or by an attendant.

Another object is to provide a lifting and lowering device which may be easily and readily placed in and removed from conventional bathtubs, which is portable and of light weight construction, and which may be manufactured at a relatively low cost.

Other objects and features of the invention will appear as the description of the particular physical embodiments selected to illustrate the invention progresses.

For a better understanding of the present invention reference should be had to the accompanying drawings wherein like numerals or reference indicate similar parts throughout the several views and wherein:

FIGURE 1 is a view in perspective of a bathlift device constructed according to the present invention with a seat member and backrest member being shown in broken lines.

FIGURE 2 is a view in vertical section on the line 2-2 of FIG. 1.

FIGURE 3 is a view in section on an enlarged scale taken on the line 3-3 of FIGURE 2.

FIGURE 4 is a detailed perspective view showing an operating lever connected to the tubular valve member extension.

FIGURE 5 is a detailed view partly in section of the control valve.

FIGURE 6 is a detailed view of the control valve taken on the line 6-6 of FIGURE 5.

FIGURE 7 is a detailed enlarged view on the line 7-7 of FIG. 2.

FIGURE 8 is a detail in section on the line 8-8 of FIGURE 7.

Before explaining the present invention in detail, it is to be understood that the invention is not limited in its application to the details of construction and arrangement of parts illustrated in the accompanying drawings, since the invention is capable of other embodiments and of being practiced or carried out in various ways. Also it is to be understood that the phraseology or terminology employed is for the purpose of description and not of limitation.

Referring to the drawings by characters of reference, the numeral 1 indicates the bottom wall of a bathtub or

2

the like which supports on its inner surface the base structure 2 of the bathlift device. The base structure 2 comprises a platform 3 extending front to rear and horizontally and which is rigidly connected at its ends to transverse supporting tubes or bars 4. Each of the bars 4 may receive at each end a suction cup member 5 having a finger grip knob 6 by which an edge portion of the cup member may be lifted to break the suction or vacuum. Adjacent the rear portion of the platform 3 is an upward extending vertical post 7 (FIG. 2) which may be rigidly secured to the platform 3 such as by the welding bead 7a.

Supported on the post 7 is the supporting and piston member 8 of the hydraulic apparatus. The supporting member 8 may be made of a metal such as aluminum or stainless steel and has at its lower end a bearing block member 9 which may be made of plastic and which is secured in the piston member 8 such as by the press fit at 10. The piston member 8, which may be hollow and rectangular in cross section, seats at its lower end on a flange or lip 11 of the block member 9. The upper end of the post 7 may be of reduced diameter to provide a shoulder adjacent the annular shoulder 12 of the post 7. The block member 9 may also have a transverse retaining pin 13 which locks in a circumferential groove 14 in the post 7 to prevent removal of the supporting member 8 from the post 7. The under surface of the block member 9 seats on a bearing pad 15 carried on the platform 3.

At its upper end, the member 8 carries a piston block 16 which has a lower portion or skirt 17 which fits within the member 8. A transverse rod member or means 18 extends through the skirt 17 and the side walls of the member 8 to hold block member 16 on the supporting member 8. The ends of the rod 18 extend outwardly beyond the flat side walls of the supporting member 8 to serve as stop means as will be further described. The upper portion of the block member 16 is cylindrical and has a threaded portion 19 which receives a threaded clamping ring 20 which clamps a sealing or piston washer 21 in position to seal the clearance space between the block member 16 and the interior wall of the reciprocal lifting or hoisting cylinder 22. The cylinder 22 and block member 16 may be made of a plastic material while the cup or washer 21 may be made of a resilient material such as rubber or neoprene.

At the upper end of the supporting member 8 adjacent the skirt 17 of the piston block 16, there is provided a bearing block 23 which is recessed rectangularly as at 24 to fit around the upper portion of the supporting member 8 and which is secured in place by fastening member 25 threadedly engaging the skirt 17. The bearing block 23 has a curved or arcuate wall 26 which conforms to the inner wall surface of the reciprocal cylinder 22. Positioned between the arcuate wall 26 and the cylinder 22 is a bearing means which may comprise a bearing material 27, such as Teflon, Celcon, or a similar synthetic material in sheet form and a support or backing 28 for the bearing material 27. The backing 28 may be a perforated sheet of metal with the bearing material 27 being adhered thereto by pressure which causes the material to enter the perforations of the metal backing 28. The bearing material 27 and backing 28 has its ends wrapped around the block 23 as at 29 to secure the bearing means to the block 23.

3

Secured within the cylinder 22 at its lower end is a cylinder block 30 which has flat side wall exterior portions to provide clearance spaces as at 31 and 32. The remainder of the exterior surface portions of the cylinder block 30 are curved or arcuate so as to correspond to the interior wall surface of the cylinder 22.

The cylinder block 30 has a rectangular aperture there-through conforming to the cross-section of the member 8 but with sufficient clearance so that at the front of the lift device, that is the side opposite the bearing block 23, there is interposed a bearing means 33 which may be similar to the bearing means, above described, that is, it comprises a Teflon or the like synthetic material adhered to a metallic backing member. The bearing member 33 is secured in position to the cylinder 22 by screws or the like 34.

Seat supporting brackets or bar members 35, 36, which may be made of tubular material such as stainless steel or aluminum, may be provided with flat end portions 37 to receive and to which are secured a seat member 38 shown in broken lines in FIG. 1. The bracket members 35, 36 are curved in vertical plane so that they bend or turn upwardly, and these upwardly turned end portions 39 extend into the clearance spaces 31 and 32 respectively. The upward extending arm portions 39 may be flattened and rigidly secured to the inside wall surface of the cylinder 22 by rivets or screws 40. These upward extending portions 39 also serve as stop members for engagement with the end portions of the rod member 18 which, as above described, extends above the clearance spaces 31, 32 in overlying relation to the end portions 39 and in their path of movement, thereby to limit the upward movement of the cylinder 22 on its supporting member 8.

The member 22 also supports a back rest member 41 which is carried by a bracket member 42 secured in position by a strap member 43 which surrounds the cylinder member 22. The strap member 43 clamps the back rest bracket member 42 in vertically adjustable position to the outside surface of the cylinder 22.

The upper end of the reciprocal cylinder 22 is closed by an end wall member or head 44 which is secured in place such as by cement or the like. This head 44 has internal lug or stop members 45 which engage the piston member 16 to limit downward movement of the reciprocal cylinder 22. The head 44 cooperates with the piston block 16 and the cylinder 22 to define a power means or pressure chamber 46. The head 44 has a fluid inlet passageway 47 for admission of fluid to the pressure chamber 46. Carried by the head 55 is a control valve 48 (FIGS. 1 and 5) having a body member 49 which is internally cylindrical and opens at its opposite ends. The body member 49 has two internal annular recesses 50 and 51. The recess 50 is in communication with a conduit 52 in a nipple 53 which is screw threaded into the inlet opening 47 of the head 44. The recess 51 communicates with an inlet passageway 54 in an inlet nipple 55 which is connected to a source of fluid under pressure by a flexible hose or conduit 56 (FIG. 1). The conduit 56 may be connected to the water outlet of a bathtub in which the bathlift device operates.

There is a hollow tubular valve member 57 within the body member 49 and which has a hand grip member or knob 58 secured to its upper end positioned externally of the valve. When the valve member 57 is in its down or seat lowering position as shown in FIG. 5, there is a port 59 through its side wall which is in registry with the annular recess 50 so that the conduit 52 is in communication with the hollow interior 60 of the valve member 57. The valve member 57 is provided above and below the port 59 with annular recesses in which are positioned sealing rings 61 and 62 respectively which may be in the form of O rings made from a suitable resilient material. The valve member 57 has an elongated

4

external cylindrical annular recess 63 below the sealing ring 62. The recess 63 is sealed at its lower end by an annular recess containing a sealing ring 64.

The valve member 57 carries a downward extending tubular extension or outlet connection 65 which terminates at its lower end adjacent to the lower end of the reciprocal cylinder 22 adjacent to the seat member 38. The extension 65 is provided with a stop ring or external shoulder 66 engageable with the lower end of the valve body member 49 to limit upward movement of the valve member 57. The bottom or outlet end of the member 65 is vertically slotted as at 67, see FIG. 4, to receive a lever operating member 68 to which it is pivoted by a pin 69. The lever 68 is fulcrumed on a pivot pin 70 which is carried by a bracket member 71 secured to the outside surface of the reciprocal cylinder 22. The bracket 71 also has a horizontal flange 72 which is provided with an aperture for slidably receiving and supporting the valve outlet extension 65. When the valve member 57 is lifted from the position shown in FIG. 5, the stop ring 66 will engage the bottom end of the valve body member 49 and the annular space 63 will serve to communicate the inlet 54 to the conduit 52.

In operation, the bathlift device which is portable is placed within a bathtub or bath and the suction or vacuum cups 5 are pressed downward to adhere the device and the base structure 2 to the bottom wall 1 of the tub. The flexible hose or conduit 56 may have its free end connected to the domestic water supply for the bathtub or to any other source of fluid supply. The valve member is lifted manually either by the control knob 58 or operating member 68 until the stop member or ring 66 limits such lifting movement by engagement with the valve body member 49. This lifting movement positions the annular space 63 to provide communication between the water inlet 54 and the conduit 52 so that the fluid supply flows through the valve and into the working pressure cylinder 46. Water under pressure entering the working pressure chamber 46 will cause the reciprocal cylinder 22 to move upward on its supporting member 8 thereby raising the seat member 38 to any desired elevated position, but preferably to a position which is above the rim of the tub. If the operator, or user fails to turn off the fluid supply, the reciprocal cylinder 22 will be limited in its upward movement by engagement of the arm portions 39 with the ends of the cross rod 18.

The apparatus may be designed such that it is not necessary to turn off the fluid supply to limit upward movement of the reciprocal cylinder 22 but the latter may be permitted to lift until the arm portions 39 stop its upward movement when the seat member 38 is above the level of the tub rim. The seat member 38 and reciprocal cylinder 22 may now be sweeled or rotated on the supporting post 7 to move the seat member outward over the rim of the tub. A patient or person desiring to bathe or be bathed now positions himself on the seat and may be rotated laterally to a position overlying the inside of the tub or the tub recess. The attendant, if there is one, may then move the hand knob 58 downward as far as it will go which positions the annular chamber 50 and the port 59 in registry with the conduit 52 thus communicating the pressure chamber 46 to the outlet conduit 65 which discharges the fluid in the pressure chamber 46 downward through the tubular extension 65 into the tub. If there is no attendant or if the person desiring to be bathed or to bathe wishes to lower himself, he may conveniently grasp the hand grip lever member 68 and move it downwardly so that such movement will act through the valve member extension 65 to move the valve member 49 downward to the position of FIG. 5 for liquid discharge from the pressure chamber 46 as above described. The weight of the person on the seat member 38 will cause the cylinder or reciprocal cylinder 22 to move downward with the bearing material 33 sliding on the front face of the piston member 8 and with the bearing material 27

sliding on the inside surface of the cylinder. In this regard it will be noted that the piston member 8 is rearwardly inclined relative to the general plane of the base 2 so that the applied forces between the piston member 8 and cylinder 22 will tend to be concentrated at the upper rear and lower front of the piston member 8 as indicated by the location of the bearing materials 27 and 33.

When the patient has bathed or been bathed, the tubular extension 65 may be lifted either by an attendant lifting the knob 58 or by the patient operating the operating member 68. This upward movement will position the annular recess 63 in communication with the inlet 54 and with the conduit 52 so that fluid from the source of supply feeding through the conduit 56 will discharge into the pressure chamber 46 thereby lifting the reciprocal cylinder 22 and its attached seat member 38 and the person resting thereon. When the arm portions 39 engage the ends of the rod 18, the upward movement will be stopped and the seat may be swiveled outward over the tub rim and the patient thereon may be removed or may move himself off the seat member.

Various modifications may be made to provide comfort and safety for the user and to increase the versatility of the bathlift device. For example, means may be provided on the device to hold seat straps and chest straps, and a folding arm rest may be provided to assist the user in standing up or sitting down. The control which is actuated by the patient may be located in other positions such as to the front of the seat and interchangeably to the right or left thereof. Provision may be made to slip the seat, back, and cylinder assembly off of the post for easy removal from the tub and so that the base assembly may be placed in the tub separately. A foldable seat and backrest may be provided for easy storage and packaging. A positive right or left side position lock with a simple release handle may be provided and also a lever operated quick hose connection. In addition the control valve may be operated to hold the seat at an intermediate position.

From the above description it will be seen that the bathlift device of the present invention may be conveniently operated by the control valve adjacent the upper part of the cylinder or by the operating lever adjacent the rear of the seat. The device may be made from lightweight materials such as plastic, aluminum, or tubular or light gauge stainless steel resulting in a lightweight unit to facilitate its portability. Domestic water supply may be used to operate the device so that when used in a bathtub, no separate external source of power is required.

The invention herein above described may be varied in construction within the scope of the claims, for the particular device selected to illustrate the invention is but one of many possible embodiments of the same. The invention therefore is not to be restricted to the precise details of the structure shown and described.

What is claimed is:

1. In a bathlift device, a base structure constructed and arranged to seat on the bottom inside wall of a tub, a supporting member extending from said structure, means for swiveling said member on said structure, a reciprocal member mounted on and surrounding and movable up and down on said supporting member, a seat member supported by and extending laterally from said reciprocal member, said reciprocal member having an end wall at its upper end, a piston head member on the upper end of said supporting member and fitting within said reciprocal member, valve means having a body member carried by said reciprocal member adjacent its upper end and having an inlet for connection to a source of fluid under pressure, a conduit connecting the interior of said body member to the interior of said reciprocal member adjacent said end wall, a tubular valve

member reciprocal in said body member, said body member and said valve member being so constructed and arranged that in one position of said valve member a clearance is provided between said body member and said valve member, said clearance providing communication between said inlet and said conduit and in another position said conduit communicates with the interior of said tubular valve member, said interior being an outlet passage in said valve member, means at the upper end of said body member and connected to said valve member to actuate the same, and means adjacent said seat member and connected to said valve member below said body member and operable to actuate said valve member.

2. The invention as defined by claim 1, and segmental bearing elements interposed between said supporting member and reciprocal member to stabilize the operation thereof, there being side clearance space between said supporting and reciprocal members afforded by the spacing of said bearing elements, a cross member on said supporting member having ends projecting into the clearance spaces, and said seat member including a pair of upturned bars which project into the clearance spaces through the lower end of the reciprocal member, said bars abutting the ends of said cross member to limit elevating of the reciprocal member on the supporting member during the operating of said device.

3. The invention as defined by claim 1, and wherein said supporting member is rectangular in cross section and said reciprocal member is cylindrical in cross section, a cross rod extending transversely through the supporting member near the upper end thereof and beyond opposite sides of the cross member and serving to attach said piston head member to the supporting member and having its ends terminating within the bore of the reciprocal member, said seat member including spaced generally upright bars which project through the lower end of the reciprocal member on opposite sides of the supporting member, said upright bars having their top ends substantially in alignment with the ends of said cross rod and adapted to abut the latter to positively limit the upward travel of the reciprocal member on the supporting member.

4. In a bathlift device, a base structure constructed and arranged to seat on the bottom inside wall of a tub, a supporting member extending from said structure, means for swiveling said member on said structure, a reciprocal member mounted on and surrounding and movable up and down on said supporting member, a seat member supported by and extending laterally from said reciprocal member, said reciprocal member having an end wall at its upper end, a piston head member on the upper end of said supporting member and fitting within said reciprocal member, valve means having a body member carried by said reciprocal member adjacent its upper end and having an inlet for connection to a source of fluid under pressure, a conduit connecting the interior of said body member to the interior of said reciprocal member adjacent said end wall, a tubular valve member reciprocal in said body member, said body member and said valve member being so constructed and arranged that in one position of said valve member said inlet communicates with said conduit and in another position said conduit communicates with the interior of said tubular valve member, said interior being an outlet passage in said valve member, a hand grip knob at the upper end of said body member and connected to said valve member to actuate the same, said tubular valve member having a tubular extension portion extending downward adjacent to and at the rear of said seat member, a bracket member on said reciprocal member and slidably supporting said tubular extension, and a lever pivoted to said bracket member and to said tubular extension and operable to move said valve member.

## References Cited by the Examiner

## UNITED STATES PATENTS

1,157,236	10/1915	McElroy	-----	251—289	X
1,793,331	2/1931	McGowan	-----	137—625.68	
2,146,403	2/1939	Nilson	-----	254—93	5
2,171,053	8/1939	White et al.	-----	224—29	
2,320,905	6/1943	Bateholts	-----	137—625.68	
2,679,890	6/1954	Zannoth	-----	248—404	X
2,763,320	9/1956	Schram	-----	248—404	
2,763,465	9/1956	Tosi et al.	-----	254—2	10
2,779,949	2/1957	Crispen	-----	4—185	

2,868,501	1/1959	Cloud et al.	-----	254—93	
2,937,002	5/1960	Schultz	-----	564—93	
2,964,093	12/1960	Lohr et al.	-----	248—429	
3,107,946	10/1963	Drake	-----	308—26	X
3,123,400	3/1964	Paulson	-----	297—347	X
3,130,956	4/1964	Mandelko	-----	254—2	
3,166,282	1/1965	Nolan	-----	248—124	

CLAUDE A. LE ROY, *Primary Examiner.*

CHANCELLOR E. HARRIS, *Examiner.*

R. P. SEITTER, *Assistant Examiner.*