

- [54] MOUNTING STRUCTURE FOR TRANSDUCER HEADS
- [75] Inventor: Marvin Camras, Glencoe, Ill.
- [73] Assignee: IIT Research Institute, Chicago, Ill.
- [22] Filed: Apr. 21, 1970
- [21] Appl. No.: 30,564

Related U.S. Application Data

- [60] Division of Ser. No. 528,934, Feb. 21, 1966, abandoned.
- [52] U.S. Cl. 179/100.2 CA, 274/4 A
- [51] Int. Cl. G11b 21/24
- [58] Field of Search 179/100.2 CA; 340/174.1 B; 226/183, 187; 274/4 A, 11 A

References Cited

UNITED STATES PATENTS

2,937,239	5/1960	Garber et al.	340/174.1 B
2,694,107	11/1954	Camras	179/100.2
2,943,852	7/1960	Quirk	226/187
3,054,860	9/1962	Goldmark	179/100.2 CA
3,154,372	10/1964	Kolm	179/100.2 CA

Primary Examiner—J. Russell Goudeau
Attorney—Hill, Sherman, Meroni, Gross and Simpson

[57] **ABSTRACT**
A mounting structure for the transducer head of a transducing system of the type having a plurality of laterally spaced head units aligned on a transverse axis and arranged for simultaneous scanning of respective, discrete channels of a tape record medium, and in which the head is mounted on a fixed support for pivotal movement about an axis perpendicular to a plane of movement of the tape record medium across said head; biased in one direction about such pivot axis and adjustment means for adjusting the angle of disposition of the transverse axis of such head relative to the direction of movement of the tape record medium across such head including a threaded member threadedly engaging into the support and having a manually grippable portion to enable manual, threaded adjustment of the member relative to the fixed support, and means movable with said threaded portion and having an annular, V-shaped groove formed therein by radial, sloping annular walls, and a spring biased detent ball entering said groove for cooperation with said groove walls.

1 Claim, 1 Drawing Figure

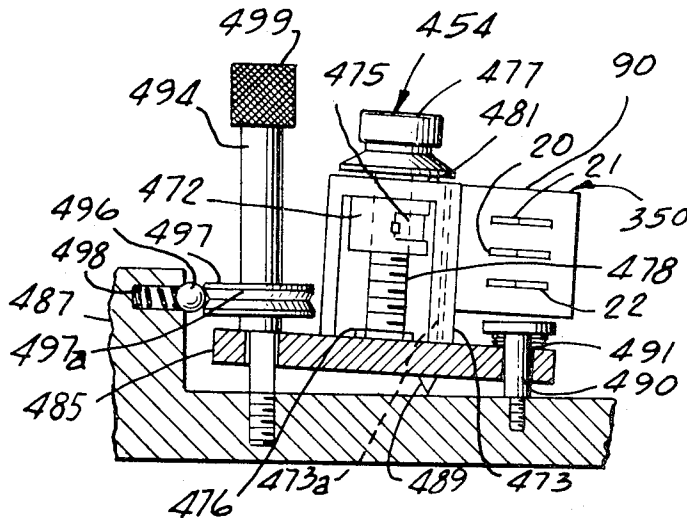

MOUNTING STRUCTURE FOR TRANSDUCER HEADS

CROSS-REFERENCES TO RELATED APPLICATIONS

The present application is a division of my copending application Ser. No. 528,934 filed Feb. 21, 1966, now abandoned in favor of a streamlined continuation, Ser. No. 62,601 filed Aug. 10, 1970 (now U.S. Pat. 3,683,107 issued Aug. 8, 1972).

SUMMARY OF THE DISCLOSURE

The invention relates to a mounting structure for a transducing head including a plurality of laterally spaced head units aligned on a transverse axis and arranged for simultaneous scanning of respective discrete channels of a tape record medium, with the channels containing demodulated, video color information. In a preferred embodiment of the invention, the head is mounted on a fixed support for pivotal movement about an axis perpendicular to a plane of movement of the tape record medium across the head, and biasing means is provided for urging the head in one direction about such pivotal axis, with adjustment being effected by means including an abutment engaging the head to limit pivotal movement thereof in the direction of bias. Said pivotal limiting means comprises a rotatable member threadedly engageable with the fixed support and having a manually grippable portion to enable manual, threaded adjustment of the member relative to the support. Means is also provided movable with the threaded portion and having an annular, V-shaped groove formed therein by radial, sloping annular walls, engageable with a spring biased detent ball which enters the groove for cooperation with the sloping walls thereof.

BRIEF DESCRIPTION OF THE DRAWING

The single FIGURE of the drawing is a somewhat diagrammatic vertical sectional view illustrating a preferred head mounting assembly in accordance with the present invention. This FIGURE corresponds to the eleventh figure of Camras application U.S. Ser. No. 62,601 filed Aug. 10, 1970 (now U.S. Pat. No. 3,683,107 issued Aug. 8, 1972).

DESCRIPTION OF THE PREFERRED EMBODIMENT

The present invention is adapted to be employed in a transducer system of the type illustrated in Camras application U.S. Ser. No. 62,601 filed Aug. 10, 1970 (now U.S. Pat. No. 3,683,107 issued Aug. 8, 1972), wherein will be found a complete description of the system and of the present invention embodied therein, and which patent is hereby incorporated herein by reference.

The single FIGURE of the drawing shows details of a preferred head mounting assembly. The reference numeral 454 designates generally a head positioning device similar to that disclosed in my copending application U.S. Ser. No. 493,271 filed Oct. 5, 1965 (now U.S. Pat. No. 3,531,600). Most of this device is made of brass. The head assembly 350 is mounted on a travelling nut 472, which is made of bronze. The head is connected to the travelling nut 472 by means of a spring (not shown). The spring is made of hardened steel, which has been heat treated at 1,500° F. and drawn at

750° F. In order to avoid play in the positioning of the head, a guide 473 on the body of the positioner in which the head mount slides must be fabricated very accurately; i.e., the dimensions of the grooved channel 473a in the positioner (0.116, 0.226 and 0.280 inch) must be attained with the highest conventional machine shop accuracy possible. It is also important that the center line of the head positioner be accurately maintained to provide the required sliding surface for the travelling nut 472.

The other components of the head positioner 454 are a drive spring 475, a washer 476, an index knob 477 for rotating a lead screw 478, and a ball and spring detent assembly indicated at 481 for determining the operating settings of the index knob 477. The lead screw 478 may be made of stainless steel and may have a thread pitch of 40 thereby providing a vertical displacement of 0.025 inch for every turn of the index knob 477.

In the drawing, the head positioning assembly 454 is shown as being mounted on a plate 485 which is pivotal relative to a fixed frame 487 about a fulcrum indicated at 489. The angle of plate 485 is shown greatly exaggerated with respect to frame 487; normally they are parallel within minutes of arc. The plate 485 is provided with apertures at opposite sides of the fulcrum 489, one aperture receiving a threaded element 490 secured to the frame 487 and confining a compression spring 491 so that the spring tends to urge the plate 485 in a clockwise direction about its fulcrum while accommodating a desired range of angular adjustment of the plate. The other aperture receives a threaded adjustment element 494 which has an enlarged shoulder abutting the plate 485 so as to limit the pivotal movement of the plate in the clockwise direction under the urging of the compression spring 491. The element 494 is threadedly engaged in the fixed frame 487 and has an appreciable range of adjustment in opposite axial directions from the position illustrated in the drawing. A differential thread may be used to give very fine adjustment corresponding to turning of 499. The position of adjustment of the element 494 represented in the drawing and corresponding to the gaps perpendicular to the tape axis for example may be termed its normal position for recording and is made apparent to an operator by means of a spring urged detent ball 496 cooperating with an annular groove 497a of a disk 497 secured to the element 494. The groove 497a has a generally V cross section so that as the element 494 is turned in either direction, the detent 496 is caused to ride on one of the sloping walls of the groove 497a against the action of the compression spring 498. The detent arrangement 496, 498 thus resists manual turning of the element 494 out of its normal position and defines a range of adjustment (determined by the width of the V-groove 497a) whose extreme limits are preferably such that the corresponding azimuth errors of the gaps of the head units are still insufficient to substantially harm the high frequency response of the head units. The element 494 may have a knurled enlarged end portion 499 for convenience of manual adjustment of the angular position of the element 494.

With pre-recorded tapes using multiple channels it has been found that misregistration may be corrected by adjusting the head angle with respect to the tape by an amount less than that required to alter appreciably the optimum azimuth alignment of the gap of the head relative to the direction of movement of the tape. Such

an adjustment which may be of the order of a minute of arc or less may be made by rotating element 494 and this structure provides for a simple alignment of the video head units 20-22 with the desired channels of a prerecorded tape. The device is easy to use for an inexperienced operator who can readily rotate the element 494 while watching the reproduced image from the tape. When the head assembly is to be utilized for a recording operation, it is a simple matter to rotate the element 494 until the device resumes its normal position with the detent ball 496 at the bottom of the groove 497a. Generally, this normal position will be one in which a line or transverse axis extending through the gaps of the head units 20-22 will extend precisely at right angles to the direction of movement of the tape across the head assembly.

The mechanism shown in the drawing can also be used to provide a variable time delay instead of using the much more expensive variable delay lines. The setting can be such as to introduce the correct delay between color channels scanned by head units 21 and 22 instead of or in connection with delay lines. The rotation of element 494 or a comparable adjustment can, of course, be servo controlled where automatic delay variation is desired for example for the purpose of correcting for flutter in tape movement. The arrangement of the head units 20-22 may be such as to give the desired displacement of the gaps relative to one another as the angle of the head assembly is changed by element 494. The smaller the lateral width of the heads in comparison to the spacing between the heads the greater the advance or delay and the greater the angular adjustment which is possible without adversely ef-

fecting high frequency response.

It will be apparent that many modifications and variations may be effected without departing from the scope of the novel concepts of the present invention.

I claim as my invention:

1. In a transducing system of the type having a transducer head including a plurality of laterally spaced head units aligned on a transverse axis and arranged for simultaneous scanning of respective, discrete channels of a tape record medium, with the channels containing demodulated, video color information, the improvement of means mounting said head on a fixed support comprising: means mounting said head on said fixed support for pivotal movement about an axis perpendicular to a plane of movement of the tape record medium across said head; biasing means urging said head in one direction about said pivot axis; adjustment means including an abutment engaging said head to limit pivotal movement thereof in the direction of bias; means mounting said abutment for selectively adjusted positioning relative to said fixed support to adjust the angle of disposition of the transverse axis of said head relative to the direction of movement of the tape record medium across said head, comprising a threaded member threadedly engaging into said support and having a manually grippable portion to enable manual, threaded adjustment of said member relative to said fixed support, and means movable with said threaded portion and having an annular, V-shaped groove formed therein by radial, sloping annular walls, and a spring biased detent ball entering said groove for cooperation with said groove walls.

* * * * *

35

40

45

50

55

60

65