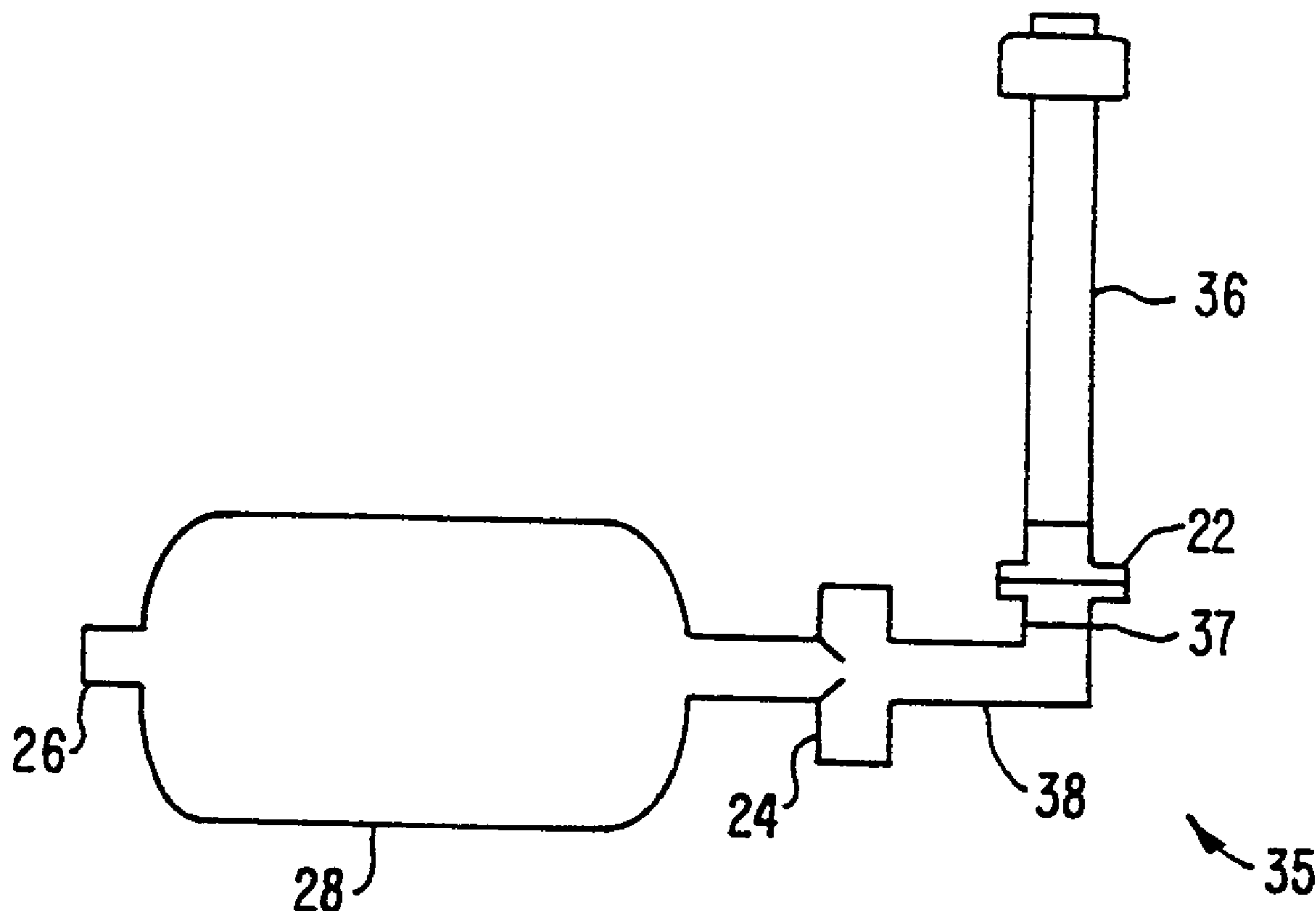




(86) Date de dépôt PCT/PCT Filing Date: 1996/02/16  
 (87) Date publication PCT/PCT Publication Date: 1996/09/19  
 (45) Date de délivrance/Issue Date: 2008/07/29  
 (85) Entrée phase nationale/National Entry: 1997/09/09  
 (86) N° demande PCT/PCT Application No.: US 1996/002097  
 (87) N° publication PCT/PCT Publication No.: 1996/028215  
 (30) Priorité/Priority: 1995/03/10 (US08/403,009)

(51) Cl.Int./Int.Cl. *A62B 7/00* (2006.01),  
*A61M 16/04* (2006.01), *A61M 16/20* (2006.01),  
*A62B 9/02* (2006.01)  
 (72) Inventeurs/Inventors:  
 LURIE, KEITH G., US;  
 SWEENEY, MICHAEL, US;  
 GOLD, BARBARA, US  
 (73) Propriétaire/Owner:  
 ADVANCED CIRCULATORY SYSTEMS, INC., US  
 (74) Agent: SMART & BIGGAR

(54) Titre : DISPOSITIF DE REANIMATION CARDIO-PULMONAIRE A STRUCTURE AUGMENTANT LA DUREE ET L'INTENSITE D'UNE PRESSION INTRA-THORACIQUE NEGATIVE  
 (54) Title: CPR DEVICE HAVING STRUCTURE FOR INCREASING THE DURATION AND MAGNITUDE OF NEGATIVE INTRA-THORACIC PRESSURE



(57) Abrégé/Abstract:  
 This invention is a CPR device having airflow impeding structure in the form of a restrictive orifice (50) or a pressure responsive valve (24) placed within or in series with a mask (52) or breathing tube (36).

**PCT**WORLD INTELLECTUAL PROPERTY ORGANIZATION  
International Bureau

## INTERNATIONAL APPLICATION PUBLISHED UNDER THE PATENT COOPERATION TREATY (PCT)

(51) International Patent Classification<sup>6</sup> :

A62B 7/00, 9/02

A1

(11) International Publication Number:

WO 96/28215

(43) International Publication Date:

19 September 1996 (19.09.96)

(21) International Application Number: PCT/US96/02097

(22) International Filing Date: 16 February 1996 (16.02.96)

(30) Priority Data:

08/403,009

10 March 1995 (10.03.95)

US

(60) Parent Application or Grant

(63) Related by Continuation

US

08/149,204 (CIP)

Filed on

9 November 1993 (09.11.93)

(71)(72) Applicants and Inventors: LURIE, Keith, G. [US/US];  
4751 Girard Avenue South, Minneapolis, MN 55409 (US).  
SWEENEY, Michael [US/US]; 1525 Goodrich Avenue, St.  
Paul, MN 55105 (US). GOLD, Barbara [US/US]; 4751  
Girard Avenue South, Minneapolis, MN 55409 (US).(74) Agents: GIBBY, Darin, J. et al.; Townsend and Townsend and  
Crew, Steuart Street Tower, 20th floor, One Market Plaza,  
San Francisco, CA 94105 (US).(81) Designated States: AL, AM, AT, AU, AZ, BB, BG, BR, BY,  
CA, CH, CN, CZ, DE, DK, EE, ES, FI, GB, GE, HU, IS,  
JP, KE, KG, KP, KR, KZ, LK, LR, LS, LT, LU, LV, MD,  
MG, MK, MN, MW, MX, NO, NZ, PL, PT, RO, RU, SD,  
SE, SG, SI, SK, TJ, TM, TR, TT, UA, UG, US, UZ, VN,  
ARIPO patent (KE, LS, MW, SD, SZ, UG), Eurasian patent  
(AZ, BY, KG, KZ, MD, RU, TJ, TM), European patent  
(AT, BE, CH, DE, DK, ES, FR, GB, GR, IE, IT, LU, MC,  
NL, PT, SE), OAPI patent (BF, BJ, CF, CG, CI, CM, GA,  
GN, ML, MR, NE, SN, TD, TG).

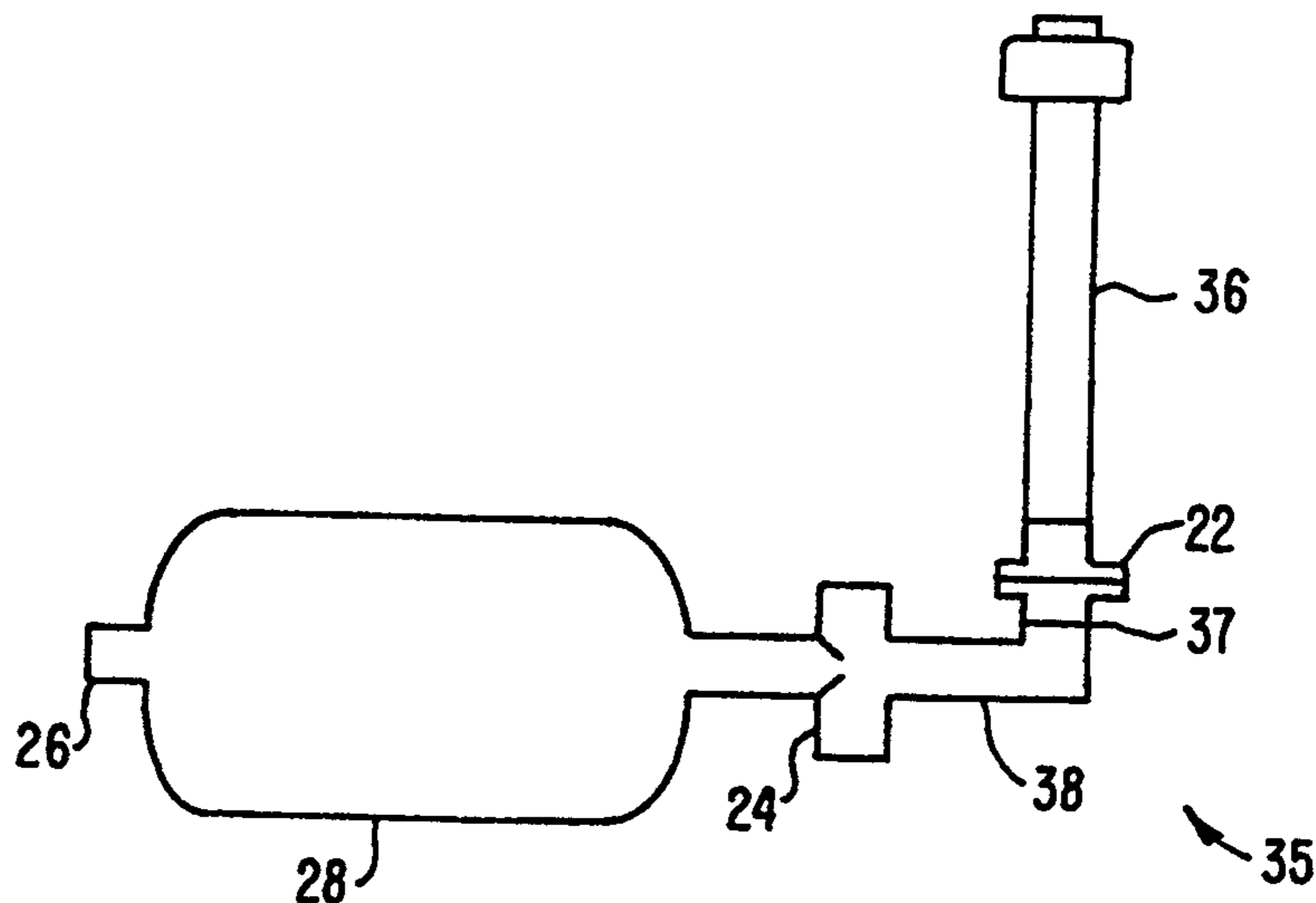
Published

*With international search report.*

(54) Title: CPR DEVICE HAVING STRUCTURE FOR INCREASING THE DURATION AND MAGNITUDE OF NEGATIVE INTRA-THORACIC PRESSURE

## (57) Abstract

This invention is a CPR device having airflow impeding structure in the form of a restrictive orifice (50) or a pressure responsive valve (24) placed within or in series with a mask (52) or breathing tube (36).



64157-540

1

5 CPR DEVICE HAVING STRUCTURE FOR INCREASING THE DURATION AND  
MAGNITUDE OF NEGATIVE INTRA-THORACIC PRESSURE

BACKGROUND OF THE INVENTION

15 1. Field of the Invention

The present invention relates generally to devices and methods used in conjunction with external chest compression and decompression as a part of cardiopulmonary resuscitation procedures. In particular, the present invention relates to  
20 devices and methods for increasing cardiopulmonary circulation induced by chest compression and decompression when performing cardiopulmonary resuscitation.

Worldwide, sudden cardiac arrest is a major cause of death and is the result of a variety of circumstances,  
25 including heart disease and significant trauma. In the event of a cardiac arrest, several measures have been deemed to be essential in order to improve a patient's chance of survival. These measures must be taken as soon as possible to at least partially restore the patient's respiration and blood  
30 circulation. One common technique, developed approximately 30 years ago, is an external chest compression technique generally referred to as cardiopulmonary resuscitation (CPR). CPR techniques have remained largely unchanged over the past two decades.

35 With traditional CPR, pressure is applied to a patient's chest in order to increase intrathoracic pressure. An increase in intrathoracic pressure induces blood movement from the region of the heart and lungs towards the peripheral arteries. Such pressure partially restores the patient's

64157-540

2

circulation. Traditional CPR is performed by actively compressing the chest by direct application of an external pressure to the chest. After active compression, the chest is allowed to expand by its natural elasticity which causes expansion of the patient's chest wall. This expansion allows some blood to enter the cardiac chambers of the heart. The procedure as described, however, is insufficient to ventilate the patient. Consequently, conventional CPR also requires periodic ventilation of the patient. This is commonly accomplished by mouth-to-mouth technique or by using positive-pressure devices, such as a self-inflating bag which relies on squeezing an elastic bag to deliver air via a mask, endotracheal tube or other artificial airway.

In order to increase cardiopulmonary circulation induced by chest compression, a technique referred to as active compression-decompression (ACD) has been developed. According to ACD techniques, the active compression phase of traditional CPR is enhanced by pressing an applicator body against the patient's chest to compress the chest. Such an applicator body is able to distribute and apply force substantially evenly over a portion of the patient's chest. More importantly, however, the applicator body is sealed against the patient's chest so that it may be lifted to actively expand the patient's chest during the decompression step. The resultant negative intrathoracic pressure induces venous blood to flow into the heart and lungs from the peripheral venous vasculature of the patient.

Also of importance to the invention are ventilation sources that are used in connection with CPR techniques to properly ventilate the patient. One type of ventilation source is the AMBU bag available from AMBU<sup>TM</sup> International, Copenhagen, Denmark. The AMBU bag can also be used in connection with a positive end-expiratory pressure (PEEP) valve, available from AMBU International, to treat some patients with pulmonary and cardiac diseases. However, until the present invention, a positive end-expiratory pressure valve in connection with a ventilation source has not been used with any CPR techniques.

64157-540

3

With both traditional CPR and ACD-CPR techniques, an increase in the amount of venous blood flowing into the heart and lungs from the peripheral venous vasculature would be desirable to increase the volume of oxygenated blood leaving the thorax during the subsequent compression phase. It would therefore be desirable to provide improved methods and apparatus for enhancing venous blood flow into the heart and lungs of a patient from the peripheral venous vasculature during both conventional CPR and ACD-CPR techniques. It would be particularly desirable to provide techniques which would enhance oxygenation and increase the total blood return to the chest during the decompression step of CPR and ACD-CPR, more particularly of ACD-CPR. This can be accomplished according to the present invention by augmentation of both negative and positive intrathoracic pressure, thereby amplifying the total intrathoracic pressure swing. An invention for providing this crucial improvement is described.

## 2. Description of the Background Art

ACD-CPR techniques are described in detail in Todd J. Cohen et al., *Active Compression-Decompression Resuscitation: A Novel Method of Cardiopulmonary Resuscitation*, American Heart Journal, Vol. 124, No. 5, pp. 1145-1150, November 1992; and Todd J. Cohen et al., *Active Compression-Decompression: A New Method of Cardiopulmonary Resuscitation*, The Journal of the American Medical Association, Vol. 267, No. 21, June 3, 1992.

The use of a vacuum-type cup for actively compressing and decompressing a patient's chest during ACD-CPR is described in a brochure of AMBU International A/S, Copenhagen, Denmark, entitled *Directions for Use of AMBU® CardioPump™*, published in September 1992. The AMBU® CardioPump™ is also disclosed in European Patent Application No. 0 509 773 A1.

35

### SUMMARY OF THE INVENTION

According to the invention, methods and devices for increasing cardiopulmonary circulation induced by chest

compression and decompression when performing cardiopulmonary resuscitation are provided. The methods and devices may be used in connection with any generally accepted CPR methods or with active compression-decompression (ACD) CPR techniques.

5 Preferably, the methods and devices will be used in connection with ACD-CPR.

Cardiopulmonary circulation is increased according to the invention by impeding airflow into a patient's lungs during the decompression phase. This increases the magnitude and  
10 prolongs the duration of negative intrathoracic pressure during decompression of the patient's chest, i.e., increases the duration and degree that the intrathoracic pressure is below or negative with respect to the pressure in the peripheral venous vasculature. By enhancing the amount of venous blood flow into  
15 the heart and lungs, since equilibration of intrathoracic pressure during decompression occurs to a greater extent from enhanced venous return rather than rapid inflow of gases into the chest via the patient's airway, cardiopulmonary circulation is increased.

20 In a specific embodiment, impeding the airflow into the patient's lungs is accomplished by decreasing or preventing ventilation during the decompression phase of CPR. The method employs the use of a flow restrictive or limiting member, such as a flow restrictive orifice disposed within or connected in  
25 series with a lumen of a ventilation tube, or a pressure-responsive valve within a lumen of the tube to impede the inflow of air. The pressure-responsive valve is biased to open to permit the inflow of air when the intrathoracic pressure falls below a threshold level. In order to properly ventilate  
30 the patient, the method preferably provides for periodically ventilating the patient through the ventilation tube after compression of the patient's chest. When periodic ventilation is performed, gases can be delivered either through the impeding step or in another embodiment they can bypass the  
35 impeding step.

An exemplary embodiment provides for covering the patient's mouth and nose with a facial mask. This mask contains means for impeding airflow into the patient's airway

during decompression of the patient's chest, e.g. either an orifice or valve as just discussed.

5 A specific embodiment further provides means for impeding air from leaving the lungs during compression of the patient's chest to further enhance cardiopulmonary circulation by enhancing positive intrathoracic pressure during the compression phase.

10 When performing cardiopulmonary resuscitation to enhance circulation according to the invention, an operator compresses a patient's chest to force blood out of the patient's thorax. The patient's chest is then decompressed to induce venous blood to flow into the heart and lungs from the peripheral venous vasculature either by actively lifting the chest (via ACD-CPR) or by permitting the chest to expand due to  
15 its own elasticity (via conventional CPR). During the decompression step, airflow is impeded from entering into the patient's lungs which enhances negative intrathoracic pressure and increases the time during which the thorax is at a lower pressure than the peripheral venous vasculature. Thus, venous  
20 blood flow into the heart and lungs from the peripheral venous vasculature is enhanced. This is because the intrathoracic pressure equilibrium during decompression occurs as a result of enhanced venous return rather than from inflow of air via the trachea. In a particular embodiment, compression and  
25 decompression of the patient's chest may be accomplished by pressing an applicator body against the patient's chest to compress the chest, and lifting the applicator to actively expand the patient's chest.

30 An apparatus for enhancing cardiopulmonary circulation according to the method comprises an improved endotracheal tube having a flow restrictive element for impeding airflow from the patient's lungs during chest decompression. A second apparatus according to the invention provides for an improved air-delivery system comprising a  
35 compressible structure having a flow restrictive element included in or attached to an opening of the compressible structure to impede the flow of gases to the patient's lungs. Also, a connector is provided for interfacing the compressible

structure to the patient, preferably by attaching a facial mask or endotracheal tube to the structure.

In another aspect of the invention, a valving system is provided for regulating airflow into a patient's lungs when performing cardiopulmonary resuscitation. The system includes a housing having an upstream region and a downstream region. A means is provided between the upstream region and the downstream region for inhibiting air from flowing from the upstream region to the downstream region when the pressure in the downstream region is less than the pressure in the upstream region. In this manner, air is inhibited from flowing into the patient's lungs during decompression of the patient's chest thereby forcing more venous blood into the chest and enhancing vital organ perfusion. A means is further provided for allowing air to flow into the downstream region when ventilating the patient. In this way, adequate ventilation can be provided to the patient during the procedure.

In one particular aspect, the inhibiting means comprises a valve which inhibits airflow from the upstream region to the downstream region when the pressure in the downstream region is less than the pressure in the upstream region. The valve preferably includes a diaphragm which is closed when the pressure in the downstream region is less than or equal to the pressure in the upstream region. Such a configuration prevents air from flowing into the patient's lungs during decompression of the patient's chest while allowing air to be exhausted from the patient's lungs during compression. Preferably, the diaphragm is constructed of a flexible membrane. Alternatively, the diaphragm can be constructed using a ball.

In another particular aspect, the diaphragm is biased to open when the pressure in the downstream region is about 2 cm H<sub>2</sub>O or greater, and more preferably at about 2 cm H<sub>2</sub>O to 4 cm H<sub>2</sub>O. Biasing of the diaphragm in this manner increases intrathoracic pressure during compression of the patient's chest to further enhance vital organ perfusion.

In still a further aspect, the means for allowing air into the downstream region includes a means for opening the



diaphragm when air is injected into the upstream region to ventilate the patient. The means for opening the diaphragm preferably includes an ambient pressure region that is adjacent the diaphragm. When air is injected into the upstream region, the pressure within the upstream region increases thereby drawing the diaphragm into the ambient pressure region and allowing the air to flow to the patient's lungs.

In yet another aspect, the means for allowing air into the downstream region includes a manually operable valve at the downstream region which is manually opened to allow air to flow into the downstream region upon return of spontaneous circulation. In this manner, a rescuer can manually open the valve when the patient begins breathing. In an alternative aspect, the means for allowing air into the downstream region comprises a pressure-responsive valve at the downstream region. The pressure-responsive valve allows air into the downstream region when the pressure in the downstream region falls below a threshold level, usually in the range from -5 cm H<sub>2</sub>O to -60 cm H<sub>2</sub>O. The pressure-responsive valve is advantageous in allowing ventilation to be provided to the patient while still employing the diaphragm to enhance the extent and duration of negative intrathoracic pressure.

The system of the invention in another aspect is provided with an air exhaust opening in the housing at the upstream region for exhausting air from the housing. A valve is provided in the exhaust opening which inhibits air from flowing into the housing through the exhaust opening. In this manner, air exhausted from the patient is in turn exhausted from the housing through the exhaust opening. In a further aspect, means are provided for preventing air from exiting the housing through the exhaust opening during injection of air into the housing when ventilating the patient. Preferably air is injected into the housing from a respiratory device, such as a respiratory bag, a ventilator, or the like, or by mouth-to-mouth breathing through a port or a mouthpiece.

In still a further aspect of the invention, an endotracheal tub, a sealed facial mask, a laryngeal mask, or other airway tube, or the like is provided and is connected to

64157-540

8

the housing at the downstream region for attachment to the patient. The endotracheal tube or like device is for insertion into the patient's airway and provides a convenient attachment for the valving system to the patient.

5           In accordance with a first broad aspect, the invention provides an improved endotracheal tube of the type having a tube suitable for insertion into the trachea and having at least a first lumen for conveying gases, wherein the improvement comprises: inflow impeding means in the  
10 first lumen for impeding inflow of gases through the first lumen of the tube, wherein the inflow impeding means comprises a pressure-responsive valve that is configured to open when the intrathoracic pressure falls below a threshold level in the range from -5 cm H<sub>2</sub>O to -60 cm H<sub>2</sub>O, and whereby  
15 airflow is impeded to a fixed or variable degree from entering the patient's lungs to enhance the extent and duration of negative intrathoracic pressure during decompression of the patient's chest to enhance venous blood flow into the heart and lungs from the peripheral venous  
20 vasculature when performing cardiopulmonary resuscitation.

          In accordance with a second broad aspect, the invention provides an improved system for delivering a preselected volume of air of the type in which a compressible structure having a first opening and a second  
25 opening, a one-way valve for the intake of air included in or attached to the first opening, and means located at the second opening for delivering a preselected volume of air, wherein the improvement is for delivering airflow to a patient's lungs when a minimum intrathoracic pressure is  
30 exceeded comprising: means for interfacing in a permanent or detachable manner said compressible structure to the patient; and means included in or attached to the second

64157-540

8a

opening of the compressible structure to impede the flow of gases to the patient's lungs until the minimum intrathoracic pressure is exceeded, wherein the means included in or attached to the second opening of the compressible structure  
5 comprises a pressure-responsive valve that is configured to open when the intrathoracic pressure falls below a threshold level in the range from -5 cm H<sub>2</sub>O to -60 cm H<sub>2</sub>O; and whereby a rise in intrathoracic pressure is slowed during decompression of the patient's chest and the extent and  
10 duration of negative intrathoracic pressure is enhanced in order to enhance venous blood flow into the heart and lungs from the peripheral venous vasculature when performing cardiopulmonary resuscitation.

In accordance with a third broad aspect, the  
15 invention provides an apparatus for assisting cardiopulmonary resuscitation comprising a valving system for regulating airflow into a patient's lungs when the patient's chest is compressed and decompressed, the system comprising: a housing having an upstream region and a  
20 downstream region; means between the upstream region and the downstream region for inhibiting air from flowing from the upstream region to the downstream region when the pressure in the downstream region is less than the pressure in the upstream region, whereby vital organ perfusion is enhanced;  
25 and means for allowing air to flow into the downstream region when ventilating the patient; the apparatus further comprising an endotracheal tube of the type having a tube suitable for inserting into the trachea and having at least a first lumen for conveying gases, the means for inhibiting  
30 airflow being within or connected in series with the first lumen to impede the inflow of gases through the first lumen, wherein the means for inhibiting airflow comprises a pressure-responsive valve that is configured to open when

64157-540

8b

the intrathoracic pressure falls below a threshold level in the range from -5 cm H<sub>2</sub>O to -60 cm H<sub>2</sub>O, and whereby airflow is impeded to a fixed or variable degree from entering the patient's lungs to enhance the extent and duration of  
5 negative intrathoracic pressure during decompression of the patient's chest to enhance venous blood flow into the heart and lungs from the peripheral venous vasculature when performing cardiopulmonary resuscitation.

In accordance with a fourth broad aspect, the  
10 invention provides Apparatus for assisting cardiopulmonary resuscitation comprising a valving system for regulating airflow into a patient's lungs when the patient's chest is compressed and decompressed, the system comprising: a housing having an upstream region and a downstream region;  
15 means between the upstream region and the downstream region for inhibiting air from flowing from the upstream region to the downstream region when the pressure in the downstream region is less than the pressure in the upstream region, whereby vital organ perfusion is enhanced; and means for  
20 allowing air to flow into the downstream region when ventilating the patient; the apparatus further comprising a compressible structure having a first opening and a second opening, a one-way valve for the intake of air included in or attached to the first opening, and means located at the  
25 second opening for delivering a preselected volume of air; means for interfacing in a permanent or detachable manner said compressible structure to the patient; and means included in or attached to the second opening of the compressible structure to impede the flow of gases to the  
30 patient's lungs until a minimum intrathoracic pressure is exceeded, wherein the means included in or attached to the second opening of the compressible structure comprises a pressure-responsive valve that is configured to open when

64157-540

8c

the intrathoracic pressure falls below a threshold level in the range from -5 cm H<sub>2</sub>O to -60 cm H<sub>2</sub>O, and whereby a rise in intrathoracic pressure is slowed during decompression of the patient's chest and the extent and duration of negative  
5 intrathoracic pressure is enhanced in order to enhance venous blood flow into the heart and lungs from the peripheral venous vasculature when performing cardiopulmonary resuscitation.

In accordance with a fifth broad aspect, the  
10 invention provides an improved endotracheal tube of the type having a tube suitable for insertion into the trachea and having at least a first lumen for conveying gases, wherein the improvement comprises: a pressure-responsive valve in the first lumen for preventing inflow of gases through the  
15 lumen of the tube, the valve having an open state and a closed state, the valve being biased to remain in the closed state to prevent all respiratory gas inflow to the lungs until the pressure within the tube falls below a threshold intrathoracic pressure generated by chest compression and  
20 decompression on a non-breathing patient, said threshold intrathoracic pressure being in the range from -5 cm H<sub>2</sub>O to -60 cm H<sub>2</sub>O whereupon the intrathoracic pressure in said range causes the valve to move to the open state to allow gases to flow passively through said valve to the lungs due  
25 to a pressure differential between the atmosphere and said negative intrathoracic pressure in the patient's chest, the valve preventing the flow of gases into the patient's lungs while in the closed state to enhance the extent and duration of negative intrathoracic pressure during decompression of  
30 the patient's chest to enhance venous blood flow into the heart and lungs from the peripheral venous vasculature when performing cardiopulmonary resuscitation.

64157-540

8d

In accordance with a sixth broad aspect, the invention provides an improved system for delivering a volume of respiratory gases of the type in which a compressible structure having a first opening and a second opening, a one-way valve for the intake of gases included in or attached to the first opening, and means located at the second opening for delivering a volume of respiratory gases, wherein the improvement comprises: means for interfacing in a permanent or detachable manner said compressible structure to the patient; and a pressure-responsive valve included in or attached to the second opening of the compressible structure to prevent the flow of all respiratory gases to the patient's lungs until the intrathoracic pressure generated by chest compression and decompression on a non-breathing patient falls below a threshold level in the range from -5 cm H<sub>2</sub>O to -60 cm H<sub>2</sub>O whereupon said intrathoracic pressure causes the valve to open to allow gases to flow passively through said valve to the lungs due to a pressure differential between the atmosphere and said negative intrathoracic pressure in the patient's chest, said valve when closed slows a rise in intrathoracic pressure during decompression of the patient's chest and to enhance the extent and duration of negative intrathoracic pressure in order to enhance venous blood flow into the heart and lungs from the peripheral venous vasculature when performing cardiopulmonary resuscitation.

In accordance with a seventh broad aspect, the invention provides a valving system for regulating airflow into a patient's lungs when performing cardiopulmonary resuscitation wherein the patient's chest is compressed and decompressed, the system comprising: a housing having an upstream region and a downstream region; a pressure-responsive valve between the upstream region and the

64157-540

8e

downstream region for preventing all respiratory gases from flowing from the upstream region to the downstream region until the pressure in the downstream region falls below a threshold level in the range from -5 cm H<sub>2</sub>O to -60 cm H<sub>2</sub>O during decompression of a non-breathing patient's chest to enhance vital organ perfusion, whereupon the negative pressure in the downstream region causes the valve to open to allow gases to passively flow to the patient's lungs due to a pressure differential between the atmosphere and the pressure in the downstream region which is below the threshold pressure; and means for allowing respiratory gases to flow into the downstream region when ventilating the patient.

In accordance with an eighth broad aspect, the invention provides a valving system for regulating airflow into a patient's lungs when performing cardiopulmonary resuscitation wherein the patient's chest is compressed and decompressed, the system comprising: a housing having an upstream region and a downstream region; a pressure-responsive valve between the upstream region and the downstream region for preventing all respiratory gases from flowing from the upstream region to the downstream region until the pressure in the downstream region falls below a threshold level in the range from -5 cm H<sub>2</sub>O to -60 cm H<sub>2</sub>O during decompression of a non-breathing patient's chest to enhance vital organ perfusion, whereupon the negative pressure in the downstream region causes the valve to open to allow gases to passively flow to the patient's lungs due to a pressure differential between the atmosphere and the pressure in the downstream region which is below the threshold pressure; a respirator connected to the housing at the upstream region for injecting gases into the housing to ventilate the patient; means for bypassing the pressure-

64157-540

8f

responsive valve to allow gases to flow into the downstream region when ventilating the patient; and an airway tube connected to the housing at the downstream region for insertion into the patient's airway.

5           In accordance with a ninth broad aspect, the invention provides a valving system for regulating airflow into a patient's lungs, the system comprising: a housing having an upstream region and a downstream region; a pressure-responsive valve between the upstream region and  
10 the downstream region for preventing all respiratory gases from flowing from the upstream region to the downstream region until the pressure in the downstream region falls below a threshold level generated by chest compression and decompression on a non-breathing patient, said threshold  
15 intrathoracic pressure being in the range from -5 cm H<sub>2</sub>O to -60 cm H<sub>2</sub>O to enhance vital organ perfusion, the valve opening due to the negative intrathoracic pressure to allow respiratory gases to passively flow to the patient's lungs due to a pressure differential between the atmosphere and  
20 said negative intrathoracic pressure in the patient's chest when the pressure in the downstream region falls below the threshold pressure; an interface member for interfacing the housing to the patient's mouth; and a ventilatory tube or a ventilatory bag for supplying respiratory gases to the  
25 patient's lungs without impedance from the pressure-responsive valve.

A further understanding of the nature and advantages of the invention will become apparent by reference to the remaining portions of the specification and  
30 drawings.



64157-540

8g

**BRIEF DESCRIPTION OF THE DRAWINGS**

Fig. 1 is a graph illustrating thoracic pressure changes over time when compressing and decompressing a patient's chest according to the present invention.

5 Fig. 2A is a schematic view illustrating airflow through a ventilation circuit when compressing a patient's chest according to the present invention.

Fig. 2B is a schematic view illustrating airflow through a ventilation circuit when decompressing a patient's  
10 chest according to the present invention.

Fig. 3 is a schematic illustration of a first alternative embodiment of a device for impeding airflow into a patient's lungs according to the present invention.

Fig. 4A is a schematic illustration of a second  
15 alternative embodiment of the device for impeding airflow into a patient's lungs according to the present invention.

Fig. 4B is a schematic illustration of the device in Fig. 4A with a common inhalation/exhalation port.

Fig. 5A is a schematic view of a one-way valve  
20 used in the device for impeding airflow according to the present invention.

Fig. 5B is a schematic view of the one-way valve in Fig. 5A that is held open after ACD-CPR has ceased.

Fig. 5C is a schematic view of a one-way valve  
25 that is closed until a threshold pressure is present in the tube according to the present invention.

64157-540

8h

Fig. 6A is a schematic view of a spring biased inflow valve and a spring biased expiration valve to be used in accordance with the present invention.

Fig. 6B is a schematic view of Fig. 6A showing the operation of the valves during outflow of air.

Fig. 6C is a schematic view of Fig. 6A showing the operation of the valves during inflow of air.

5 Fig. 7 is a schematic view of a single valve that is spring biased from both sides to be used as an inflow valve and an expiration valve according to the present invention.

10 Fig. 8 is a schematic view of a flow restricting orifice to be used with a flow restrictive device according to the present invention.

Fig. 9 is a schematic view of an exemplary embodiment of the device for impeding airflow into a patient's lungs according to the present invention.

15 Figs. 10A-10C are schematic views illustrating another embodiment of the present invention allowing for periodic patient ventilation through a bypassing valve.

20 Fig. 11 is a schematic view of an exemplary valving system for regulating airflow into a patient's lungs according to the present invention. The valving system is shown with air being exhausted from a patient's lungs during compression of the patient's chest.

Fig. 12 illustrates the valving system of Fig. 11 during decompression or resting of the patient's chest.

25 Fig. 13 illustrates the valving system of Fig. 11 with a pressure-responsive valve being opened when the negative intrathoracic pressure in the patient's chest exceeds a threshold amount during decompression of the patient's chest.

30 Fig. 14 illustrates the valving system of Fig. 11 with a diaphragm being opened during injection of air into the housing when ventilating the patient.

Fig. 15 illustrates the valving system of Fig. 11 with a manually operable valve being opened to allow air into the patient's lungs upon return of spontaneous circulation.

35 Fig. 16A is a cutaway side view of exemplary valving system according to the present invention.

Fig. 16B is a top view of a deflector and a fenestrated mount of the valving system of Fig. 16A.

64157-540

10

Fig. 16C is an alternative embodiment of the valving system of Fig. 16A.

Fig. 17 is a schematic view of an alternative embodiment of a valving system having a ball as a diaphragm.

5

#### DETAILED DESCRIPTION OF SPECIFIC EMBODIMENTS

According to the present invention, methods and devices for increasing cardiopulmonary circulation induced by chest compression and decompression when performing cardiopulmonary resuscitation are provided. Such methods and devices may be used in connection with any method of CPR in which intrathoracic pressures are intentionally manipulated to improve cardiopulmonary circulation. For instance, the present invention would improve standard manual CPR, "vest" CPR, CPR with a newly described Hiack Oscillator ventilatory system which operates essentially like an iron-lung-like device, interposed abdominal compression-decompression CPR, and active compression-decompression (ACD) CPR techniques. Although the present invention may improve all such techniques, the following description will refer primarily to improvements of ACD-CPR techniques in order to simplify discussion. However, the claimed methods and devices are not exclusively limited to ACD-CPR techniques.

The proper performance of ACD-CPR to increase cardiopulmonary circulation is accomplished by actively compressing a patient's chest with an applicator body. Preferably, this applicator body will be a suction-type device that will adhere to the patient's chest, such as the AMBU® CardioPump™, available from AMBU™ International, Copenhagen, Denmark. After the compression step, the adherence of the applicator body to the patient's chest allows the patient's chest to be lifted to actively decompress the patient's chest. The result of such active compression-decompression is to increase intrathoracic pressure during the compression step, and to increase the negative intrathoracic pressure during the decompression step thus enhancing the blood-oxygenation process and enhancing cardiopulmonary circulation. ACD-CPR techniques are described in detail in Todd J. Cohen et al., Active

64157-540

11

*Compression-Decompression Resuscitation: A Novel Method of Cardiopulmonary Resuscitation*, American Heart Journal, Vol. 124, No. 5, pp. 1145-1150, November 1992; Todd J. Cohen et al., *Active Compression-Decompression: A New Method of Cardiopulmonary Resuscitation*, The Journal of the American Medical Association, Vol. 267, No. 21, June 3, 1992; and J. Schultz, P. Coffeen, et al., *Circulation*, 89:684-693, 1994.

The present invention is especially useful in connection with ACD-CPR techniques. In particular, the invention improves ACD-CPR by providing methods and devices which impede airflow into a patient's lungs to enhance negative intrathoracic pressure during the decompression of the patient's chest, thus increasing the degree and duration of a pressure differential between the thorax (including the heart and lungs) and the peripheral venous vasculature. Enhancing negative intrathoracic pressure with simultaneous impedance of movement of gases into the airway thus enhances venous blood flow into the heart and lungs and increases cardiopulmonary circulation.

In a broad sense, the present invention provides for occluding a patient's airway to prevent foreign (outside) air from flowing to a patient's lungs during the active decompression step of ACD-CPR to enhance and sustain the duration of negative intrathoracic pressure and enhance blood oxygenation and cardiopulmonary circulation during both active decompression and the subsequent compression phase. The patient's airway may be occluded or inflow of gases impeded by any suitable device or mechanism such as by an endotracheal tube, a device attached to an endotracheal tube, a facial mask, a mouth piece used in mouth-to-mouth resuscitation, oropharyngeal airway, laryngeal mask airway, and the like.

A further aspect of the present invention provides for allowing impeded air to flow into the patient's lungs during the active decompression step of ACD-CPR in order to provide some ventilation to the patient while still enhancing the extent and duration of negative intrathoracic pressure to enhance blood oxygenation. Impeding airflow to the patient's

64157-540

12

lungs may be accomplished by any flow restrictive element such as an orifice, a one-way valve, a spring biased or other valve which is set to open when the negative intrathoracic pressure is in the range from about 0 cm H<sub>2</sub>O to -100 cm H<sub>2</sub>O, or the like. A valve designed to open at a threshold pressure value may be either fixed or variable, i.e., the pressure at which the valve opens may be adjusted or may be permanently fixed.

Similarly, another aspect of the invention provides for air to be impeded from leaving the patient's lungs during compression of the patient's chest to further enhance cardiopulmonary circulation by enhancing intrathoracic pressure during the compression phase. Typically, air is impeded from leaving the lungs during the compression phase when the positive intrathoracic pressure is in the range from about 2 cm H<sub>2</sub>O to 50 cm H<sub>2</sub>O.

Another aspect of the present invention provides for ventilating the patient during ACD-CPR. Ventilation of the patient is performed at about every two to 10 compressions, preferably every five compressions, thus providing sufficient fresh air for adequate gas exchange with the blood in the lungs to the patient. Ventilating the patient may be accomplished by any device or method suitable such as by mouth-to-mouth resuscitation, by a compressible or collapsible structure, by a ventilatory bag such as the AMBU™ bag available from AMBU, Copenhagen, Denmark, or the like, which provide means for delivering a preselected volume of air. Ventilation could also be superimposed on the compression phase to further augment positive intrathoracic pressure. Furthermore, periodic ventilation could be performed either through the impeding step or by bypassing the impeding step altogether.

Referring now to Fig. 1, a graph illustrating thoracic pressure changes over time when compressing and decompressing the patient's chest is shown. Area 10 represents the amount of thoracic pressure during the compression phase of ACD-CPR. Cross-hatched area 12 represents the negative thoracic pressure during the decompression step of ACD-CPR without a flow restrictive means to restrict the flow of air into the patient's lungs. Double cross-hatched area 14 represents the increase in negative thoracic pressure when the

64157-540

13

patient's airway is occluded according to the present invention during the decompression step of ACD-CPR. The significance of the increase in negative intrathoracic pressure during the decompression step is that more venous blood is forced into the chest from the peripheral venous vasculature. Consequently, more blood is allowed to be oxygenated and more blood is forced out of the chest during the next compression.

In an exemplary embodiment, airflow may be impeded to the patient's lungs during decompression of the patient's chest by placing a ventilatory mask over the patient's mouth and nose. The ventilatory mask also has a pressure-responsive valve attached to prevent airflow to the patient's lungs until the negative intrathoracic pressure of the patient reaches a threshold amount. Also attached to the mask and the pressure-responsive valve is a ventilatory source to provide ventilation to the patient. The ventilatory source may be any device or apparatus suitable for properly ventilating the patient. Preferably, the ventilation source will be an AMBU bag. When ventilation is needed, the AMBU<sup>™</sup> bag may be squeezed to force air into the patient's lungs. The AMBU bag is described in U.S. Patent No. 5,163,424.

In an alternative embodiment, a ventilation source, preferably an AMBU<sup>™</sup> bag, is used in connection with an improved endotracheal tube. A pressure-responsive valve or other flow restrictive element is placed between the AMBU<sup>™</sup> bag and the endotracheal tube. Preferably, the valve will be positioned within a tube that connects the AMBU<sup>™</sup> bag to the endotracheal tube. The combination of the endotracheal tube with the AMBU<sup>™</sup> bag with adapter can be included in the definition of a "ventilation tube." Before ACD-CPR is performed on the patient, the endotracheal tube is placed in the patient's trachea. During decompression of the patient's chest, the valve prevents airflow to the patient's lungs until the intrathoracic pressure reaches a threshold amount. Additionally, the AMBU<sup>™</sup> bag may be used to ventilate the patient at a desired time. Also included in this embodiment is a one-

64157-540

14

way expiration valve. This valve allows for expiration of air from the patient during the compression step.

In a modification of either of the first two embodiments, an pressure-responsive expiration valve may also be inserted between the AMBU™ bag (or comparable ventilation source) and the mask or endotracheal tube. This valve works in a similar manner to the pressure-responsive valve which restricts airflow into the patient's lungs. However, the pressure-responsive expiration valve restricts airflow from the patient's lungs during the compression step of ACD-CPR. An equivalent valve is a positive end-expiratory pressure (PEEP) valve available from AMBU™ International, Copenhagen, Denmark. Use of such an pressure-responsive expiration valve during compression may further increase intrathoracic pressure and thereby force more blood out of the thorax.

In another alternative embodiment, an improved endotracheal tube is used to restrict airflow into the patient's lungs during the active decompression step. Included in the endotracheal tube is a flow restrictive element which operates to impede air from flowing into the patient's lungs. When the endotracheal tube is inserted into the patient's trachea and the patient's chest is actively decompressed, the flow restrictive element impedes air from flowing to the patient's lungs slowing the rise in intrathoracic pressure and thus enhancing blood oxygenation.

When using the improved endotracheal tube during ACD-CPR, periodic ventilation of the patient will usually still be performed to enhance gas exchange to the patient. With the improved endotracheal tube, such manual ventilation may be accomplished by placing a ventilation source at the opening of the endotracheal tube to force oxygen through the endotracheal tube and into the patient's lungs.

Referring now to Fig. 2A, a schematic view illustrating airflow through a ventilation circuit 20 when compressing a patient's chest according to the present invention is shown. During ACD-CPR, the chest is actively compressed forcing air out of the lungs. This air is allowed



to expire through a one-way expiration valve 22 within a ventilation circuit 20.

Referring now to Fig. 2B, the same schematic is shown illustrating airflow through the ventilation circuit 20 when decompressing the patient's chest. When the patient's chest is actively decompressed, a negative intrathoracic pressure is created. When this pressure reaches a threshold amount, the inflow valve 24 will open causing air to flow through the ventilation circuit 20 into the patient's lungs. Air is allowed into the ventilation circuit 20 through a ventilation valve 26 and into a ventilation bag 28. From the ventilation bag 28, the air passes through the inflow valve 24 when the negative intrathoracic pressure reaches the threshold amount. The ventilation bag 28 is also used to manually ventilate the patient during ACD-CPR as required.

The method as discussed in connection with Figs. 2A and 2B requires the chest to be compressed in the range from about 3.5 cm to 5 cm per compression and at a rate from about 60 to 100 compressions per minute for adults.

Referring now to Fig. 3, a schematic illustration of a first alternative embodiment of a device 35 for impeding airflow into a patient's lungs according to the present invention is shown. The device 35 comprises an endotracheal tube 36 which is placed into the patient's trachea and provides a ventilation passageway. Connected to the endotracheal tube 36 is a transition tube 38 which connects the endotracheal tube 36 to the ventilation bag 28. Although the endotracheal tube 36 is shown connected to the ventilation bag 28, the endotracheal tube 36 can be used alone or in connection with the ventilation bag 28. The ventilation bag 28 can comprise any type of ventilation source capable of ventilating the patient such as a compressible or collapsible structure. Preferably, the ventilation bag 28 consists of an AMBU bag. Attached or connected to the end of the ventilation bag 28 is a one-way ventilation valve 26. The ventilation valve 26 serves to introduce air into the device 35. Attached or connected to the transition tube 38 is an inflow pressure-responsive valve 24. The inflow valve 24 is biased so that it opens when the

negative intrathoracic pressure in the patient's chest reaches a threshold amount. As shown, only one inflow valve 24 is included in the device 35. However, the invention is not limited to only one inflow valve 24. Alternatively, a plurality of inflow valves 24 could be connected in series along the ventilation tube 38. The inflow valve 24 is also not limited to being connected in the center of the transition tube 38, but may be positioned anywhere along the transition tube 38. The inflow valve 24 could be permanently attached to the ventilation bag 28 or transition tube 38 or could be detachable. Alternatively, the inflow valve 24 could be connected to the ventilation bag 28 itself or to the endotracheal tube 36.

The device 35 also contains a one-way expiration valve 22 which allows for air to be expired from the patient's lungs. This generally occurs during the compression phase of ACD-CPR. To insure that the air expired from the patient's lungs will exit through the expiration valve 22, a one-way fish mouth valve 37 (the preferred valve) or any other type of one-way valve can be placed between the inflow valve 24 and the expiration valve 22. Alternatively, the inflow valve 24 itself may be configured as a one-way valve. In either case, air flowing from the endotracheal tube 36 toward the ventilation bag 28 will be forced to expire through the expiration valve 22.

The device 35 may be further modified to include a pressure-responsive expiration valve 39 (not shown) located between the endotracheal tube 36 and the transition tube 38. The pressure-responsive expiration valve works in a reverse manner to that of the inflow valve 24. Specifically, the pressure-responsive expiration valve is biased so that during the compression step of ACD-CPR, air will be allowed to expire from the patient's lungs only when the intrathoracic pressure reaches a threshold amount. The increase in intrathoracic pressure caused by the pressure-responsive expiration valve 39 during compression may assist in forcing more blood out of the thorax and reduce atelectasis of the lungs.

64157-540

17

The purpose of the ventilation bag 28 is to provide ventilation to the patient during ACD-CPR. When the ventilation bag 28 comprises an AMBU<sup>TM</sup> bag or similar bag used for ventilation, ventilation of the patient may be performed by merely squeezing the AMBU<sup>TM</sup> bag with a human hand. This forces air to the patient's lungs as desired.

Referring to Fig. 4A, a second alternative embodiment of the device for impeding airflow into a patient's lungs according to the present invention is shown. This particular embodiment is a modified and improved endotracheal tube. Hence, the second alternative embodiment comprises an endotracheal tube 36 having two lumens at its proximal end. The first lumen is an outflow lumen 40, and the second lumen is an inflow lumen 42. Located within outflow lumen 40 is a one-way pressure-responsive expiration valve 44 which operates in a manner similar to that discussed in connection with Fig. 3, except that the expiration valve 44 is specifically designed as a one-way valve. Located within inflow lumen 42 is a one-way pressure-responsive inflow valve 45 which operates to impede airflow to the lungs as discussed in connection with Fig. 3, except that the inflow valve 45 is also specifically designed as a one-way valve. Also shown in inflow lumen 42 and outflow lumen 40 is an O-ring 46 which will be discussed subsequently. Inflow valve 45 and expiration valve 44 are designed as one-way valves so that during the compression phase, air can only be expired from the patient through the endotracheal tube 36 when the intrathoracic pressure reaches a threshold amount. At that moment, expiration valve 44 opens and air expires from the patient through the outflow lumen 40. During decompression, air cannot flow through the endotracheal tube 36 to the patient's lungs until the negative intrathoracic pressure reaches a threshold amount. At that moment, inflow valve 45 opens allowing air to flow through inflow lumen 42 to the patient's lungs. Air is prevented from entering through the outflow lumen 40 because of the one-way expiration valve 44.

Ventilation is possible with the embodiment disclosed in Figs. 4A and 4B if the inflow lumen 42 is connected to a ventilation source such as a ventilation bag. When the

ventilation bag is squeezed, air is allowed to flow through the inflow lumen 42, through the endotracheal tube 36, and to the patient's lungs. In this embodiment, expiration valve 44 is designed so that during ventilation, expiration valve 44 will remain temporarily closed preventing air flowing through inflow lumen 42 escape through outflow lumen 40.

Fig. 5A is a schematic view of a one-way inflow valve 45 used in a device for impeding airflow according to the present invention. The inflow valve 45 operates so as to allow air only to flow in one direction. As shown, the spring biased inflow valve 45 is completely open. However, the invention also functions properly if the spring biased inflow valve 45 or the spring biased expiration valve 44 are not fully open. Upon successful completion of ACD-CPR, the O-ring 46 that is positioned above the inflow valve 45 is repositioned so that inflow valve 45 is held open as shown in Fig. 5B. Such a positioning of O-ring 46 allows for unimpeded airflow to the patient once there is a return of spontaneous circulation and the inflow valve 45 is no longer needed. An O-ring 46 is also used in a similar manner to lock the one-way expiration valve 44 in an open position upon return of spontaneous circulation. Fig. 5C illustrates the one-way inflow valve 45 in a closed position. When closed, the inflow of air through the inflow valve 45 is occluded.

Fig. 6A illustrates an inflow valve 47 that is spring biased and an expiration valve 48 that is also spring biased. The inflow valve 47 and the expiration valve 48 are connected in series and may be used in the first alternative embodiment as discussed in connection with Fig. 3, or with the preferred embodiment discussed following in connection with Fig. 9. As shown in Fig. 6C, during the active decompression step, the inflow valve 47 is biased such that it will open when the negative intrathoracic pressure reaches a threshold amount. During the compression phase of ACD-CPR the expiration valve 48 will open to allow air to expire from the patient's lungs when the intrathoracic pressure within the patient's chest reaches a threshold amount as shown in Fig. 6B. Since neither inflow valve 47 nor expiration valve 48 are one-way valves, a fish

mouth valve 37 used in connection with a one-way expiration valve 22 as discussed in connection with Fig. 3 must be used. Other valves designed upon a similar principle as the fish mouth valve combination with a one-way expiration valve could also be used. Only one inflow valve 24 and one positive end pressure valve 44 are shown in Figs. 6A-6C. However, a plurality of inflow valves 47 and/or expiration valves 48 may be connected in a permanent or detachable manner in series to impede the inflow and outflow of air.

Although the valves in Figs. 6A-6C are shown as being spring-biased, any other valves designed upon a similar principle would work equally as well. The use of such valves as disclosed in Figs. 6A-6C is only one embodiment and valves constructed according to various other methods and materials is also within the scope of the invention.

As shown in Fig. 7, the inflow valve 47 and the expiration valve 48 may be combined into one joint valve 49 as shown. The joint valve 49 will operate in a manner similar to the two valves 47 and 48 as described in connection with Fig. 6.

Fig. 8 illustrates a flow restricting orifice 50 to be used to either impede the airflow into or out of a patient's lungs. The flow restricting orifice 50 operates so that during the decompression step of ACD-CPR airflow is impeded from entering into the patient's lungs, thus increasing the negative intrathoracic pressure. During the compression step, the flow restricting orifice 50 operates to increase the thoracic pressure in the patient's chest by restricting air from existing from the patient's lungs.

Fig. 9 illustrates an exemplary embodiment for impeding airflow into a patient's lungs according to the present invention. As shown, the device 51 comprises a ventilation bag 28 that is connected to a facial mask 52 by an inflow valve 24 and an expiration valve 22. Although the facial mask 52 is shown connected to the ventilation bag 28, the facial mask 52 can be used alone or in connection with the ventilation bag. Between the inflow valve 24 and the expiration valve 22 is a one-way fish mouth valve 37 or any

other type of one-way valve to prevent air from exiting the patient's lungs and flowing to the ventilation bag 28. The ventilation bag 28 also contains a one-way ventilation valve 26 for allowing air to inflow into the device 51. The exemplary  
5 embodiment operates in a manner similar to that of the first alternative embodiment as discussed in connection with Fig. 3. However, instead of inserting an endotracheal tube 36 into the patient's airway, the facial mask 52 is placed over the patient's mouth and nose. A facial strap 54 (not shown) may  
10 also be wrapped around the head of the patient to secure the ventilation mask 52 to the patient's face.

Device 51 is preferably used in connection with an oral airway device (not shown) to prevent the patient's airway from becoming occluded, e.g. by the patient's tongue. The oral  
15 airway device can be any device that is used to keep the patient's tongue from slipping backward and occluding the airway. Preferably, the oral airway device will be curved and constructed of a plastic material and may or may not be attached to the device 51.

20 During the decompression phase of ACD-CPR, air is prevented from entering into the patient's lungs through the threshold inflow valve 24 thus increasing the negative intrathoracic pressure. During the compression phase, air is allowed to expire from the patient's lungs through the  
25 expiration valve 22. Also, the patient can be ventilated during ACD-CPR by manually squeezing the ventilation bag 28. Consequently, the preferred embodiment serves to enhance cardiopulmonary circulation by increasing the negative intrathoracic pressure to force more blood into the chest from  
30 the peripheral venous vasculature.

Figs. 10A - 10C show another embodiment of the present invention which allows the patient to be ventilated by bypassing the impeding step. The embodiment comprises a ventilation tube 60 with a proximal end 62 and a distal end 64  
35 that is connected to the patient. The ventilation tube 60 has a one-way bypass valve 66 and a one-way pressure responsive valve 68. The ventilation tube 60 may also have a manual switch 70 attached to the bypass valve 66 and extending through

a side of the ventilation tube 60. As shown in Fig. 10A, the switch 70 may be set in a closed position so that the one-way pressure responsive valve 68 opens when the threshold pressure of the valve 68 has been exceeded. At this point, the valve 68 opens allowing for ventilation of the patient. As shown in Fig. 10B, the one-way pressure responsive valve 68 may be bypassed altogether by manually placing the switch 70 in the open position so that the bypass valve 66 is opened allowing air to flow to the patient. Fig. 10C illustrates the operation of the bypass valve 66 with the switch 70 in an inactive mode. Here, the rescuer performing ventilation may do so without added resistance from the impedance step as in Fig. 10A. Instead, bypass valve 66 opens only when the pressure at the proximal end of the tube 62 is greater than atmospheric pressure (0 mmHg), preferably in a range from about 0 mmHg to 5 mmHg. During decompression of the patient's chest, the one-way bypass valve 66 remains closed unless atmospheric pressure is exceeded. Thus, the patient is ventilated only when the rescuer performing ventilation causes the pressure at the proximal end of the tube 62 to exceed atmospheric pressure. The function of the one-way bypass valve 66 may be performed by many different threshold valve designs which are known in the art.

In another aspect of the invention, an exemplary valving system is provided for enhancing the duration and extent of negative intrathoracic pressure during the decompression phase of CPR while still providing adequate ventilation to the patient. The valving system is employed to slow the rapid equilibrium of intrathoracic pressure in the chest during decompression by impeding or inhibiting the flow of air into the patient's chest. Lowering of the intrathoracic pressure in this manner provides a greater coronary perfusion pressure and hence forces more venous blood into the thorax. The valving system can be employed in a variety of CPR methods where intrathoracic pressures are intentionally manipulated to improve cardiopulmonary circulation, including "vest" CPR, CPR incorporating a Heimlich ventilatory system, intraposed

abdominal compression-decompression CPR, standard manual CPR, and the like, and will find its greatest use with ACD-CPR.

Referring to Figs. 11-15, an exemplary embodiment of a valving system 100 is shown schematically. The valving system 100 includes a housing 101 having an upstream region 102 and a downstream region 104. Held between the upstream region 102 and downstream region 104 is a diaphragm 106. The diaphragm 106 is preferably a flexible or elastomeric membrane that is held over the downstream region 104 to inhibit air from flowing from the upstream region 102 to the downstream region 104 when the pressure in the downstream region 104 is less than the pressure in the upstream region 102, except when positive pressure, i.e. greater than atmospheric, is developed in the upstream region 102 when ventilating the patient. The valving system 100 further includes a valve 108 having a plug 110. As described in greater detail hereinafter, the valve 108 is included to provide ventilation to the patient when opened. The valve 108 can be manually opened by axial translation or it can be automatically opened when the pressure in the downstream region 104 reaches or exceeds a threshold amount, or both. Included at the upstream region 102 is an air intake opening 112 and an air exhaust opening 114. Air is delivered into the housing 101 through the air intake opening 112, while air is exhausted from the housing 101 through the air exhaust opening 114. An accordion valve 116, fishmouth valve, or the like is provided between the air intake opening 112 and the air exhaust opening 114. As described in greater detail hereinafter, the accordion valve 116 is used to prevent air that is injected into the air intake opening 112 from exiting the air exhaust opening 114 when ventilating the patient. A filter 117 is provided for filtering air injected into the housing 101. Optionally, a filter 119 can be provided in the downstream region 104 for preventing excess body fluids from entering into the system 100.

Operation of the valving system 100 during compression of a patient's chest is illustrated in Fig. 11. As the patient's chest is compressed, air is forced from the patient's lungs and into the downstream region 104. The air



forced into the downstream region 104 is directed against the diaphragm 106 forcing the diaphragm into an ambient pressure region 118. Air in the downstream region 104 is then allowed to escape into the upstream region 102 where it is exhausted through the air exhaust opening 114. Optionally, the diaphragm 106 can be biased so that it will not be forced into the ambient pressure region 118 until the pressure within the downstream region 104 is about 2 cm H<sub>2</sub>O or greater, and more preferably at about 2 cm H<sub>2</sub>O to 4 cm H<sub>2</sub>O.

Operation of the valving system 100 during decompression (or resting) of the patient's chest is illustrated in Fig. 12. As the patient's chest is actively lifted (or allowed to expand on its own), air is drawn from the downstream region 104 and into the patient's lungs, thereby reducing the pressure in the downstream region 104. The resulting pressure differential between the regions 102, 104 holds the diaphragm 106 over the downstream region 104 to prevent air from the upstream region 102 from flowing to the downstream region 104. In this way, air is inhibited from flowing into the patient's lungs during decompression of the patient's chest, thereby lowering the intrathoracic pressure to increase the coronary perfusion pressure and to force more venous blood into the thorax.

Various ways of providing ventilation to the patient using the valving system 100 are described in Figs. 13-15. Fig. 13 illustrates airflow into the downstream region 104 and to the patient's lungs during decompression of the patient's chest after a threshold amount of negative intrathoracic pressure has been reached. Ventilation in this manner is advantageous in that the valving system 100 can be employed to produce at least a threshold amount of intrathoracic pressure to enhance blood flow into the heart and lungs. Once such a pressure is reached, some air is allowed to flow to the patient's lungs to ventilate the patient.

Air is allowed to enter the downstream region 104 when the threshold amount of intrathoracic pressure is reached by configuring the valve 108 to be a threshold valve. The valve 108 can be configured in a variety of ways, with a

primary function being that the valve 108 allows air to flow into the downstream region 104 when a threshold amount of intrathoracic pressure is reached. This is preferably accomplished by configuring the plug 110 to be flexible in one direction so that when the pressure in the downstream region 104 reaches or exceeds the threshold amount, the plug 110 is flexed to provide an opening 126 between the upstream region 102 and downstream region 104. When the plug 110 is flexed, air flows from the lower pressure upstream region 102 into the downstream region 104 and to the patient's lungs. The plug 110 therefore acts as a one-way valve allowing air to flow from the upstream region 102 into the downstream region 104 when the threshold amount is reached, but does not allow airflow from the downstream region 104 to the upstream region 102.

Preferably, the plug 110 will flex to open when the pressure within the downstream region 104 is in the range from about 0 mm H<sub>2</sub>O to 50 cm H<sub>2</sub>O, more preferably at about 20 cm H<sub>2</sub>O to 40 cm H<sub>2</sub>O, and more preferably at about 30 cm H<sub>2</sub>O. Alternatively, the valve 108 can be placed in the downstream region 104 so that air flows into the downstream region 104 directly from the atmosphere when the valve 108 is open.

Ventilating the patient by injecting air into the upstream region 102 is illustrated in Fig. 14. As air is injected through the intake opening 112, it passes into the accordion valve 116 and forces the valve 116 against a wall 120 and covers a hole 122 in the wall 120 to prevent airflow through the exhaust opening 114. When the accordion valve 116 is closed, air flows through a wall 124 of the valve 116 and into the upstream region 102. Alternatively, a fishmouth valve can be used in place of the accordion valve 116. Upon injection of the air into the upstream region 102, the pressure within the upstream region 102 becomes greater than the pressure in the ambient pressure region 118 and causes the diaphragm 106 to be drawn into the ambient pressure region 118. An opening between the upstream region 102 and the downstream region 104 is created allowing air to flow into the downstream region 104 and into the patient's lungs. Preferably, the patient will be manually ventilated by injecting air into the

64157-540

25

intake opening 112 about every three to seven compressions of the chest, and more preferably about every five compressions of the chest.

Configuration of the valving system 100 upon return of spontaneous circulation is illustrated in Fig. 15. When the patient's circulation is restored, the valve 108 is manually opened by translating the valve 108 to remove the plug 110 from aperture 126. The upstream region 102 and downstream region 104 are then placed in communication to allow air to be freely exchanged between each of the regions 102, 104. Although shown extending through the upstream region 102, the valve 108 can alternatively be placed anywhere along the downstream region 104.

The valve 108 can be configured as a pressure-responsive valve (see Fig. 13), as a manually operable valve (see Fig. 15), or both. Further, the valving system 100 can alternatively be provided with two or more valves that are similar to the valve 108. For example, one valve could be non-translatably held in the housing 101 and provided with a pressure-responsive plug 110, with the other valve being translatably mounted. In this manner, the valve with the flexible plug functions as a pressure-responsive valve and opens when the threshold pressure is reached, while the translatable valve functions to place the regions 102, 104 in communication upon manual operation after spontaneous circulation is achieved.

Referring to Figs. 16A and 16B, an exemplary embodiment of a valving system 130 will be described. The valving system 130 is constructed of a housing 132 having an intake opening 134, an exhaust opening 136, and a delivery opening 138. Included in the exhaust opening 136 is a one-way valve 140 which allows air to flow from the housing 132 and out the exhaust opening 136. An accordion valve 140 is provided between the intake opening 134 and an exhaust opening 136 to prevent air injected into the intake opening 134 from exiting through the exhaust opening 136. Preferably, the intake opening 134 is configured to be attachable to a respiratory device, such as a respiratory bag (including an AMBU™ bag), a

ventilator, a mouthpiece or port for mouth-to-mouth breathing through the system 130, or the like. The delivery opening 138 is preferably configured for connection to an endotracheal tube or other airway tube, a sealed facial mask, a laryngeal mask, or the like.

Within the housing 132 is an upstream region 142, a downstream region 144, and an ambient pressure region 146. Separating the upstream region 142 from the downstream region 144 is a diaphragm 148. The diaphragm 148 is preferably constructed of an elastomeric material. The housing 132 is preferably cylindrical in geometry at the downstream region 144, with the diaphragm 148 resting on the cylinder during ambient conditions. During decompression of the patient's chest, the reduction in pressure in the downstream region 144 draws the diaphragm 148 against the end of the cylinder to prevent exchange of air between the upstream region 142 and downstream region 144. During compression of the patient's chest, air is forced into the downstream region 144 to force the diaphragm 148 into the ambient pressure region 146 so that the air exhausted from the patient's chest can be exhausted through the exhaust opening 136.

As shown best in Fig. 16B, the valving system 130 is further provided with a fenestrated mount 150. In one aspect, the fenestrated mount 150 serves as a mount for holding the diaphragm 148 over the downstream region 144. The fenestrated mount 150 further provides the ambient pressure region 146. Fenestrations 152 are provided in the mount 150 to allow air to be exchanged through the mount 150. Included on the mount 150 is a deflector 154 for deflecting air around the fenestrated mount 150. Various other deflectors 156 are provided in the housing 132 for directing airflows between the regions 142 and 144. A filter 158 is provided in the housing 132 to filter air injected into the housing 132. Optionally, a filter 159 can be provided to prevent excess body fluids from entering into the system 130.

The valving system 130 further includes a threshold valve 160 at the downstream region 144. When the pressure within the downstream region 144 is less than the threshold

amount, the threshold valve 160 is opened to allow air to flow into the downstream region 144. The threshold valve 160 includes a spring 162 which is configured to extend when the threshold amount is reached. Alternatively, the threshold valve 160 can be configured similar to the valve 110. Other configurations which allow the for air to enter the downstream region 144 when the desired intrathoracic pressure is reached or exceeded can also be provided. For example, in a further alternative, the diaphragm 148 can be constructed to function as a threshold valve to allow air to flow into the patient's lungs when a threshold amount of intrathoracic pressure is reached. The diaphragm 148 can be fashioned as a threshold valve by constructing the diaphragm 148 of an elastomeric material and by providing at least one hole near the periphery. When the diaphragm rests on the cylinder forming the downstream region 144, the hole is positioned beyond the periphery of the cylinder and in the upstream region 142. As a vacuum is created in the downstream region 144, the diaphragm is drawn into the downstream region 144 until the hole is stretched over the cylinder and overlaps with both the upstream region 142 and the downstream region 144. In this way, a fluid path is provided between the regions 142 and 144 when the threshold pressure is reached in the downstream region 144. Another alternative of a threshold valve 111 is illustrated in Fig. 16C. The valve 111 is pivot mounted within the downstream region 144 and is biased closed by a spring 113. When the threshold pressure within the downstream region 144 is reached, the spring 113 is compressed and air is drawn into the downstream region 144.

Referring back to Fig. 16A, the threshold valve 160 can optionally be provided within the housing 132 at the upstream region 142. The threshold valve 160 can further optionally be provided with an on/off switch for opening the valve 160 when spontaneous circulation is achieved. In this manner, a rescuer can open the valve 160 to allow for free exchange of air to the patient's lungs when needed. In one alternative as shown in Fig. 16C, the mount 150 can be slidable mounted within the housing 132 so that the mount 150 can be

64157-540

28

vertically raised to lift the diaphragm 148 from the downstream region 144 upon successful resuscitation of the patient, thereby providing a free flow of air to the patient. The mount 150 can be slidable mounted within the housing 132 by attaching the mount 150 to an extension member 133 that is slidable within the housing 132. The member 133 preferably includes the intake and exhaust openings 134 and 136. In this way, an easy grasping surface is provided when translating the member 133 to open or close the diaphragm 148. If the diaphragm 148 were also fashioned as a threshold valve as previously described, the need for the valves 108 or 111 could be eliminated.

The housing 132 can conveniently be constructed in several parts which are connected together at various connection points. In this manner, the housing can be taken apart for connection to other devices, for repair, for cleaning, and the like. For example, one connection point can be conveniently provided near the filter 158 for removably connecting the portion of the housing having the intake opening 134, the valve 140, and the exhaust opening 136. Alternatively, a connection point can be provided near the mount 150 to provide easy access to the mount 150 for cleaning.

The valving system 130 can conveniently be incorporated with a variety of devices useful in CPR procedures. For example, the valving system 130 can be incorporated within a respiratory bag, such as an AMBU™ bag. Alternatively, the valving system 130 can be included as part of a respiratory circuit having both a respiratory bag and an endotracheal tube or other airway tube, with the valving system 130 positioned between the bag and the tube. In further alternative, the valving system 130 can be added to an endotracheal tube alone. Alternatively, the valving system can be incorporated into a mask, an oralpharyngeal airway, a laryngeal mask or other ventilatory devices.

Referring to Fig. 17, an alternative valving system 164 will be described. The valving system 164 is shown schematically and operates essentially identical to the valving system 100, the difference being that the valving system 164 includes a ball or spherical member 166 as the diaphragm.

During decompression of the patient's chest, the pressure in a downstream region 168 is less than the pressure in an upstream region 170 which draws the ball 166 over the downstream region 168. The valving system 164 can optionally be provided with a  
5 spring 172 or other biasing mechanism to hold the ball 166 over the downstream region 168 during compression of the patient's chest until a threshold pressure is reached or exceeded in the downstream region 168 as previously described.

10 Although the foregoing invention has been described in some detail by way of illustration and example, for purposes of clarity of understanding, it will be obvious that certain changes and modifications may be practiced within the scope of the appended claims.

64157-540

30

CLAIMS:

1. An improved endotracheal tube of the type having a tube suitable for insertion into the trachea and having at least a first lumen for conveying gases, wherein the improvement comprises:

inflow impeding means in the first lumen for impeding inflow of gases through the first lumen of the tube, wherein the inflow impeding means comprises a pressure-responsive valve that is configured to open when the intrathoracic pressure falls below a threshold level in the range from -5 cm H<sub>2</sub>O to -60 cm H<sub>2</sub>O, and whereby airflow is impeded to a fixed or variable degree from entering the patient's lungs to enhance the extent and duration of negative intrathoracic pressure during decompression of the patient's chest to enhance venous blood flow into the heart and lungs from the peripheral venous vasculature when performing cardiopulmonary resuscitation.

2. The tube of claim 1, wherein the pressure-responsive valve is disposed within or connected in series with the lumen of the ventilation tube, and the inflow impeding means further comprises means for bypassing air around the pressure-responsive valve.

3. An improved system for delivering a preselected volume of air of the type in which a compressible structure having a first opening and a second opening, a one-way valve for the intake of air included in or attached to the first opening, and means located at the second opening for delivering a preselected volume of air, wherein the improvement is for delivering airflow to a patient's lungs when a minimum intrathoracic pressure is exceeded comprising:



64157-540

31

means for interfacing in a permanent or detachable manner said compressible structure to the patient; and

means included in or attached to the second opening of the compressible structure to impede the flow of gases to the patient's lungs until the minimum intrathoracic pressure is exceeded, wherein the means included in or attached to the second opening of the compressible structure comprises a pressure-responsive valve that is configured to open when the intrathoracic pressure falls below a threshold level in the range from -5 cm H<sub>2</sub>O to -60 cm H<sub>2</sub>O; and whereby a rise in intrathoracic pressure is slowed during decompression of the patient's chest and the extent and duration of negative intrathoracic pressure is enhanced in order to enhance venous blood flow into the heart and lungs from the peripheral venous vasculature when performing cardiopulmonary resuscitation.

4. The system of claim 3, wherein the pressure-responsive valve is disposed within or connected in series in a permanent or detachable manner with the compressible structure.

5. The system of claim 3, wherein the interfacing means further comprises a facial mask, an endotracheal tube, or an oralpharyngeal airway, and wherein the interfacing means further comprises a laryngeal mask.

6. An apparatus for assisting cardiopulmonary resuscitation comprising a valving system for regulating airflow into a patient's lungs when the patient's chest is compressed and decompressed, the system comprising:

a housing having an upstream region and a downstream region;

64157-540

32

means between the upstream region and the downstream region for inhibiting air from flowing from the upstream region to the downstream region when the pressure in the downstream region is less than the pressure in the upstream region, whereby vital organ perfusion is enhanced; and

means for allowing air to flow into the downstream region when ventilating the patient;

the apparatus further comprising an endotracheal tube of the type having a tube suitable for inserting into the trachea and having at least a first lumen for conveying gases, the means for inhibiting airflow being within or connected in series with the first lumen to impede the inflow of gases through the first lumen, wherein the means for inhibiting airflow comprises a pressure-responsive valve that is configured to open when the intrathoracic pressure falls below a threshold level in the range from -5 cm H<sub>2</sub>O to -60 cm H<sub>2</sub>O, and whereby airflow is impeded to a fixed or variable degree from entering the patient's lungs to enhance the extent and duration of negative intrathoracic pressure during decompression of the patient's chest to enhance venous blood flow into the heart and lungs from the peripheral venous vasculature when performing cardiopulmonary resuscitation.

7. The apparatus of claim 6 wherein the pressure-responsive valve is within the first lumen of the tube, and the apparatus further comprising means for bypassing air around the inflow impeding means.

8. Apparatus for assisting cardiopulmonary resuscitation comprising a valving system for regulating airflow into a patient's lungs when the patient's chest is compressed and decompressed, the system comprising:

64157-540

33

a housing having an upstream region and a downstream region;

means between the upstream region and the downstream region for inhibiting air from flowing from the upstream region to the downstream region when the pressure in the downstream region is less than the pressure in the upstream region, whereby vital organ perfusion is enhanced; and

means for allowing air to flow into the downstream region when ventilating the patient;

the apparatus further comprising a compressible structure having a first opening and a second opening, a one-way valve for the intake of air included in or attached to the first opening, and means located at the second opening for delivering a preselected volume of air;

means for interfacing in a permanent or detachable manner said compressible structure to the patient; and

means included in or attached to the second opening of the compressible structure to impede the flow of gases to the patient's lungs until a minimum intrathoracic pressure is exceeded, wherein the means included in or attached to the second opening of the compressible structure comprises a pressure-responsive valve that is configured to open when the intrathoracic pressure falls below a threshold level in the range from -5 cm H<sub>2</sub>O to -60 cm H<sub>2</sub>O, and whereby a rise in intrathoracic pressure is slowed during decompression of the patient's chest and the extent and duration of negative intrathoracic pressure is enhanced in order to enhance venous blood flow into the heart and lungs from the peripheral venous vasculature when performing cardiopulmonary resuscitation.

64157-540

34

9. The apparatus of claim 8, wherein the interfacing means further comprises a facial mask, an endotracheal tube, or an oralpharyngeal airway, and wherein the interfacing means further comprises a laryngeal mask.

5 10. A use of the apparatus of any one of claims 6 to 9 to regulate the airflow into the patient's lungs when performing cardiopulmonary resuscitation.

11. An improved endotracheal tube of the type having a tube suitable for insertion into the trachea and having at  
10 least a first lumen for conveying gases, wherein the improvement comprises:

a pressure-responsive valve in the first lumen for preventing inflow of gases through the lumen of the tube, the valve having an open state and a closed state, the valve  
15 being biased to remain in the closed state to prevent all respiratory gas inflow to the lungs until the pressure within the tube falls below a threshold intrathoracic pressure generated by chest compression and decompression on a non-breathing patient, said threshold intrathoracic  
20 pressure being in the range from -5 cm H<sub>2</sub>O to -60 cm H<sub>2</sub>O whereupon the intrathoracic pressure in said range causes the valve to move to the open state to allow gases to flow passively through said valve to the lungs due to a pressure differential between the atmosphere and said negative  
25 intrathoracic pressure in the patient's chest, the valve preventing the flow of gases into the patient's lungs while in the closed state to enhance the extent and duration of negative intrathoracic pressure during decompression of the patient's chest to enhance venous blood flow into the heart  
30 and lungs from the peripheral venous vasculature when performing cardiopulmonary resuscitation.

64157-540

35

12. The apparatus of claim 11, further comprising means for bypassing respiratory gases around pressure-responsive valve to ventilate the patient.

13. An improved system for delivering a volume of  
5 respiratory gases of the type in which a compressible structure having a first opening and a second opening, a one-way valve for the intake of gases included in or attached to the first opening, and means located at the second opening for delivering a volume of respiratory gases,  
10 wherein the improvement comprises:

means for interfacing in a permanent or detachable manner said compressible structure to the patient; and

a pressure-responsive valve included in or attached to the second opening of the compressible structure  
15 to prevent the flow of all respiratory gases to the patient's lungs until the intrathoracic pressure generated by chest compression and decompression on a non-breathing patient falls below a threshold level in the range from -5 cm H<sub>2</sub>O to -60 cm H<sub>2</sub>O whereupon said intrathoracic  
20 pressure causes the valve to open to allow gases to flow passively through said valve to the lungs due to a pressure differential between the atmosphere and said negative intrathoracic pressure in the patient's chest, said valve when closed slows a rise in intrathoracic pressure during  
25 decompression of the patient's chest and to enhance the extent and duration of negative intrathoracic pressure in order to enhance venous blood flow into the heart and lungs from the peripheral venous vasculature when performing cardiopulmonary resuscitation.

30 14. The apparatus of claim 13, wherein the pressure-responsive valve is disposed in a lumen of an endotracheal tube.

64157-540

36

15. The apparatus of claim 13, wherein the interfacing means further comprises a facial mask.

16. The apparatus of claim 13, wherein the interfacing means further comprises an endotracheal tube.

5 17. The apparatus of claim 13, wherein the interfacing means further comprises an oralpharyngeal airway.

18. The apparatus of claim 13, wherein the interfacing means further comprises a laryngeal mask.

19. A valving system for regulating airflow into a  
10 patient's lungs when performing cardiopulmonary resuscitation wherein the patient's chest is compressed and decompressed, the system comprising:

a housing having an upstream region and a downstream region;

15 the housing is configured to be coupled to an interfacing means adapted to interface with a patient's airway;

a pressure-responsive valve between the upstream region and the downstream region for preventing all  
20 respiratory gases from flowing from the upstream region to the downstream region until the pressure in the downstream region falls below a threshold level in the range from -5 cm H<sub>2</sub>O to -60 cm H<sub>2</sub>O during decompression of a non-breathing patient's chest to enhance vital organ perfusion,  
25 whereupon the negative pressure in the downstream region causes the valve to open to allow gases to passively flow to the patient's lungs due to a pressure differential between the atmosphere and the pressure in the downstream region which is below the threshold pressure; and

64157-540

37

means for allowing respiratory gases to flow into the downstream region when ventilating the patient.

20. The system of claim 19, further comprising a means to bypass the pressure responsive valve to allow airflow  
5 from the downstream region to the upstream region.

21. The system of claim 20, wherein the bypass means includes a diaphragm which is closed when the pressure in the downstream region is less than or equal to the pressure in the upstream region.

10 22. The system of claim 21, wherein the diaphragm is a flexible membrane.

23. The system of claim 21, wherein the diaphragm is a ball.

24. The system of claim 21, wherein the diaphragm is  
15 biased to open when the pressure in the downstream region is about 2 cm H<sub>2</sub>O or greater.

25. The system of claim 21, wherein the means for allowing gases into the downstream region comprises a means for opening the diaphragm when gases are injected into the  
20 upstream region to ventilate the patient.

26. The system of claim 25, wherein the means for opening the diaphragm includes an ambient pressure region adjacent the diaphragm, wherein gases injected into the upstream region increases the pressure within the upstream  
25 region and forces the diaphragm into the ambient pressure region to open the diaphragm and to allow gases to flow to the patient's lungs.

27. The system of claim 19, wherein the means for allowing gases into the downstream region comprises a

64157-540

38

manually operable valve at the downstream region which is manually opened to allow gases to flow unimpeded into the downstream region upon return of spontaneous breathing by the patient.

5 28. The system of claim 19, further comprising a respiratory member connected to the housing at the upstream region for injecting gases into the housing to ventilate the patient, the injected gases passing through the means for allowing gases to flow into the downstream region with no  
10 resistance from the pressure-responsive valve.

29. The system of claim 28, wherein the respiratory member includes a respiratory bag or a mouth piece.

30. The system of claim 28, wherein the housing includes a gas exhaust opening at the upstream region for  
15 exhausting gases from the housing.

31. The system of claim 30, further comprising a valve in the exhaust opening which inhibits gases from flowing into the housing through the exhaust opening.

32. The system of claim 30, further comprising means  
20 for preventing gases from exiting the housing through the exhaust opening during injection of gases from the respiratory bag.

33. The system of claim 32, wherein the means for preventing gases from exiting the housing is a fish mouth  
25 valve.

34. The system of claim 19, further comprising connection member connected to the housing at the downstream region for connecting the housing to the patient.



64157-540

39

35. The system of claim 34, wherein the connection member includes an endotracheal tube, a facial mask, or a laryngeal mask.

36. A valving system for regulating airflow into a patient's lungs when performing cardiopulmonary resuscitation wherein the patient's chest is compressed and decompressed, the system comprising:

a housing having an upstream region and a downstream region;

10 a pressure-responsive valve between the upstream region and the downstream region for preventing all respiratory gases from flowing from the upstream region to the downstream region until the pressure in the downstream region falls below a threshold level in the range  
15 from -5 cm H<sub>2</sub>O to -60 cm H<sub>2</sub>O during decompression of a non-breathing patient's chest to enhance vital organ perfusion, whereupon the negative pressure in the downstream region causes the valve to open to allow gases to passively flow to the patient's lungs due to a pressure differential between  
20 the atmosphere and the pressure in the downstream region which is below the threshold pressure;

a respirator connected to the housing at the upstream region for injecting gases into the housing to ventilate the patient;

25 means for bypassing the pressure-responsive valve to allow gases to flow into the downstream region when ventilating the patient; and

an airway tube connected to the housing at the downstream region for insertion into the patient's airway.

64157-540

40

37. The system of claim 36, wherein the respirator includes a respiratory bag or a ventilation port.

38. The system of claim 36, wherein the airway tube includes an endotracheal tube.

5 39. The system of claim 36, further comprising a facial mask or a laryngeal mask operably attached to the airway tube.

40. The system of claim 36, wherein gases flow through the means for allowing gases to flow into the downstream  
10 region without resistance from the pressure-responsive valve.

41. A valving system for regulating airflow into a patient's lungs, the system comprising:

a housing having an upstream region and a  
15 downstream region;

a pressure-responsive valve between the upstream region and the downstream region for preventing all respiratory gases from flowing from the upstream region to the downstream region until the pressure in the downstream  
20 region falls below a threshold level generated by chest compression and decompression on a non-breathing patient, said threshold intrathoracic pressure being in the range from -5 cm H<sub>2</sub>O to -60 cm H<sub>2</sub>O to enhance vital organ perfusion, the valve opening due to the negative  
25 intrathoracic pressure to allow respiratory gases to passively flow to the patient's lungs due to a pressure differential between the atmosphere and said negative intrathoracic pressure in the patient's chest when the pressure in the downstream region falls below the threshold  
30 pressure;

64157-540

41

an interface member for interfacing the housing to the patient's mouth; and

a ventilatory tube or a ventilatory bag for supplying respiratory gases to the patient's lungs without  
5 impedance from the pressure-responsive valve.

42. The system of claim 41, wherein the interface member includes an endotracheal tube, a facial mask, a laryngeal mask, or an oropharyngeal airway.

SMART & BIGGAR

OTTAWA, CANADA

PATENT AGENTS

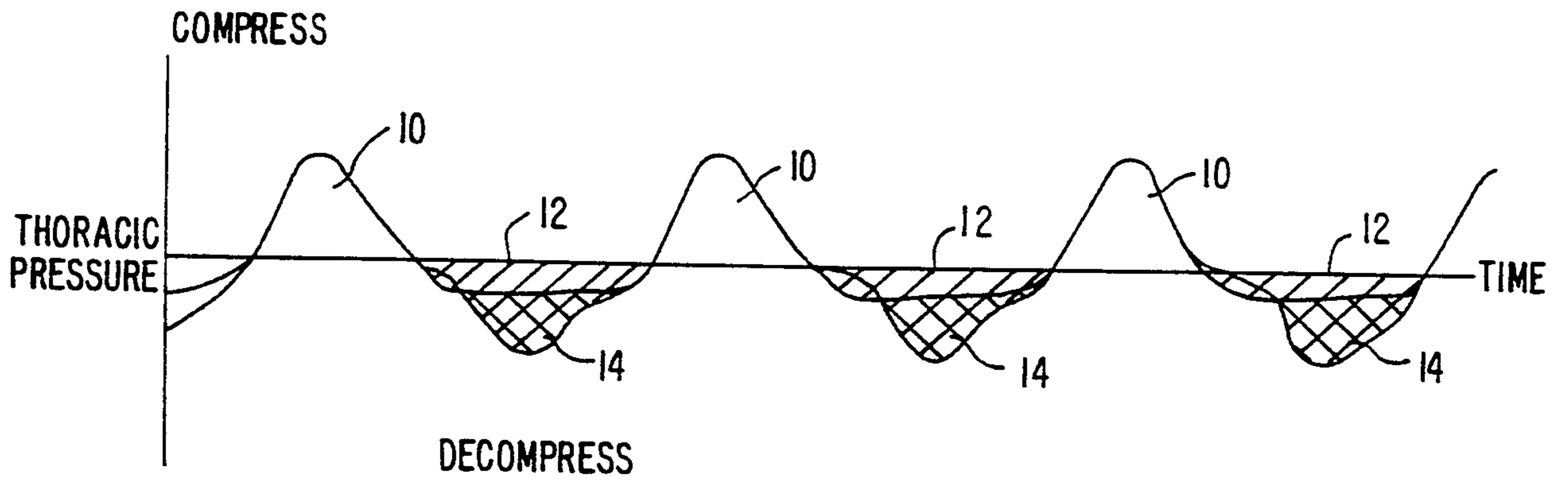


FIG. 1.

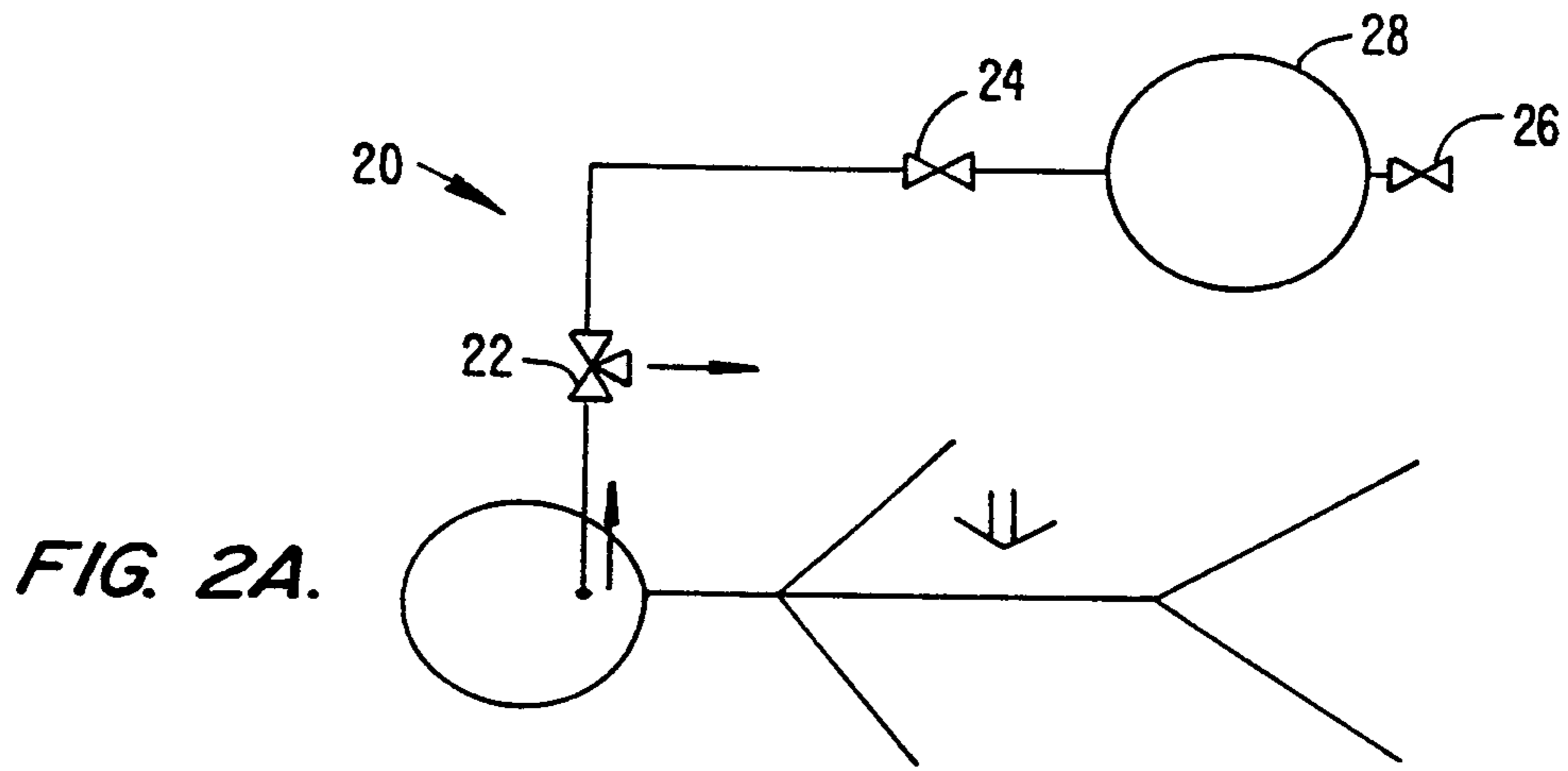


FIG. 2A.

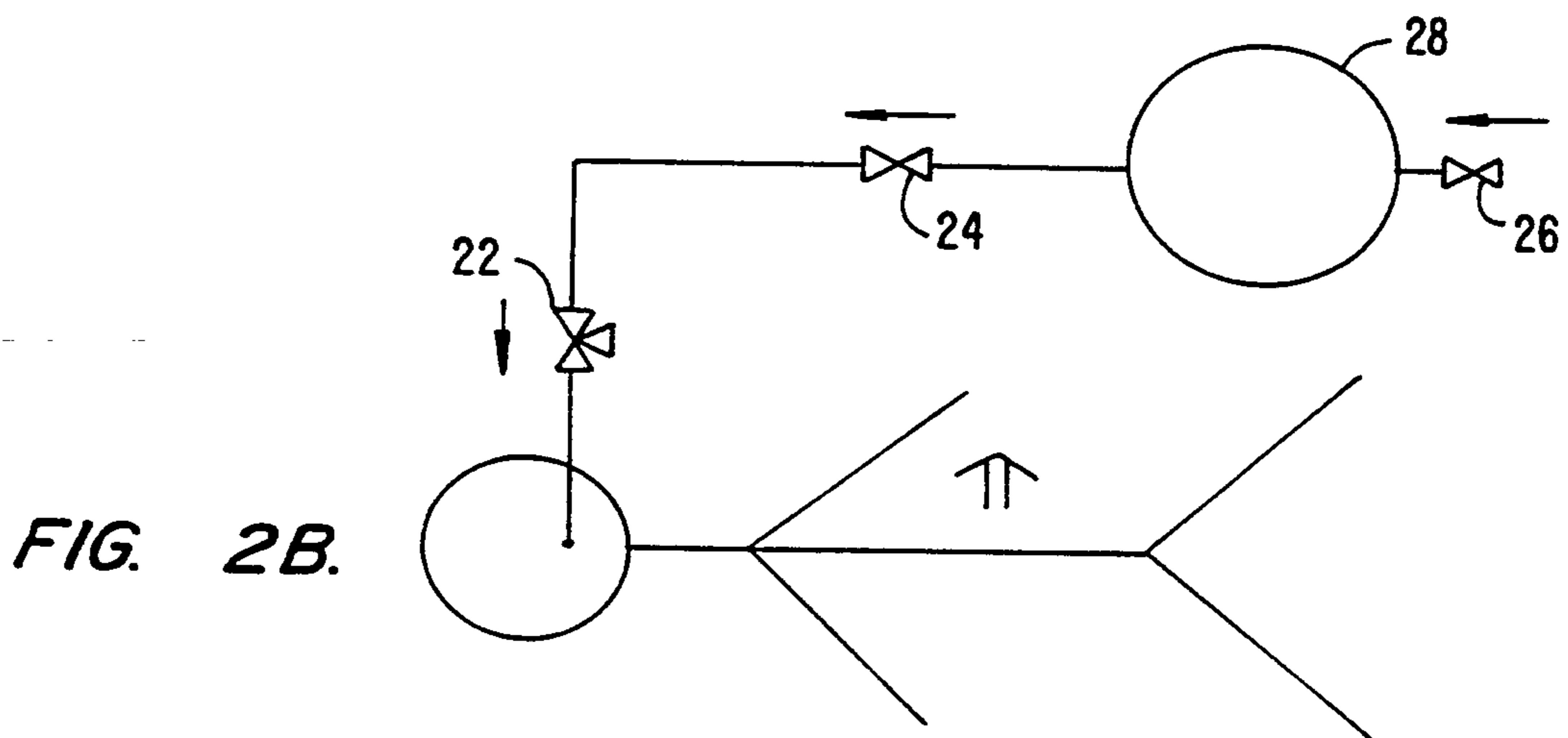


FIG. 2B.

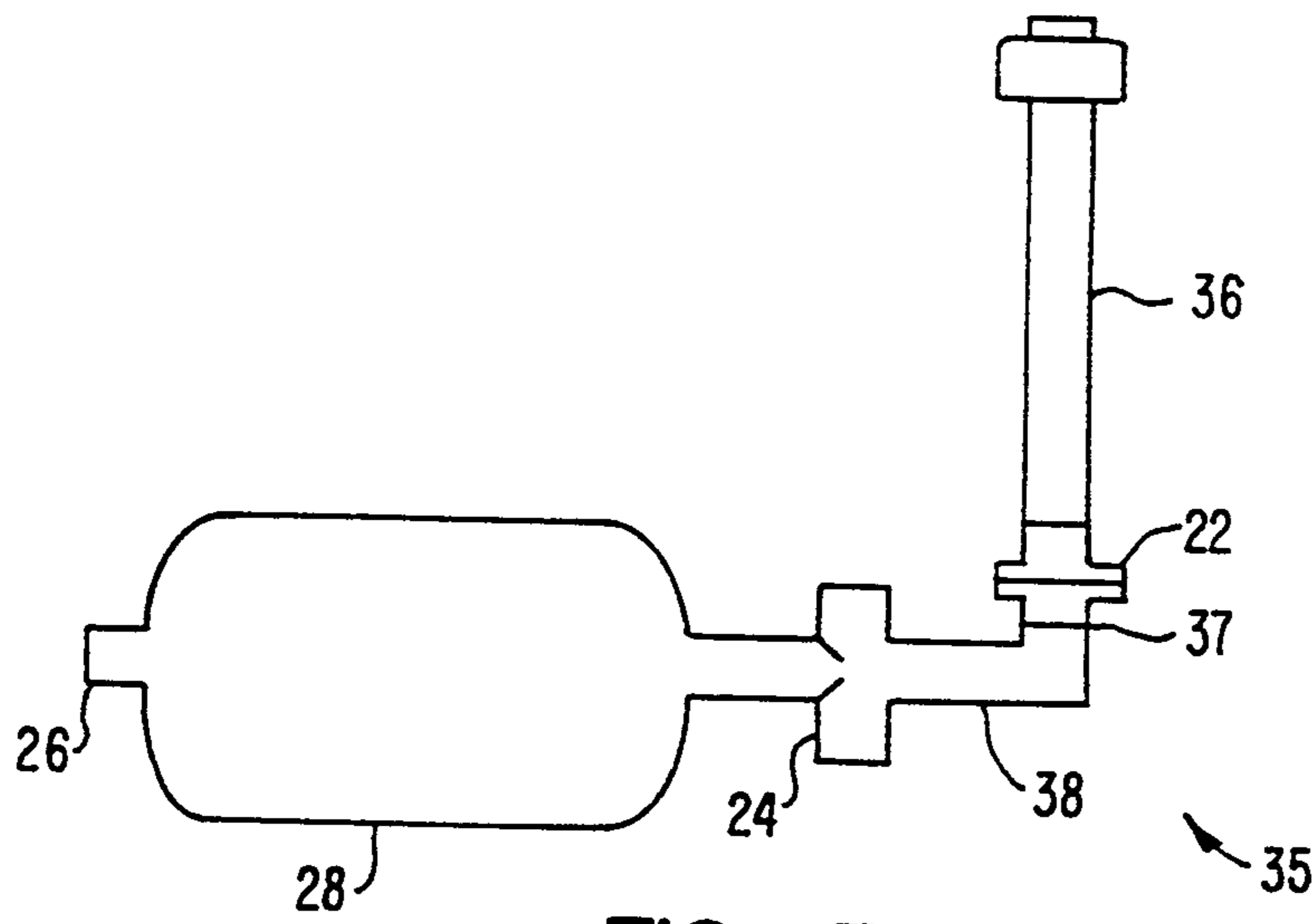


FIG. 3.

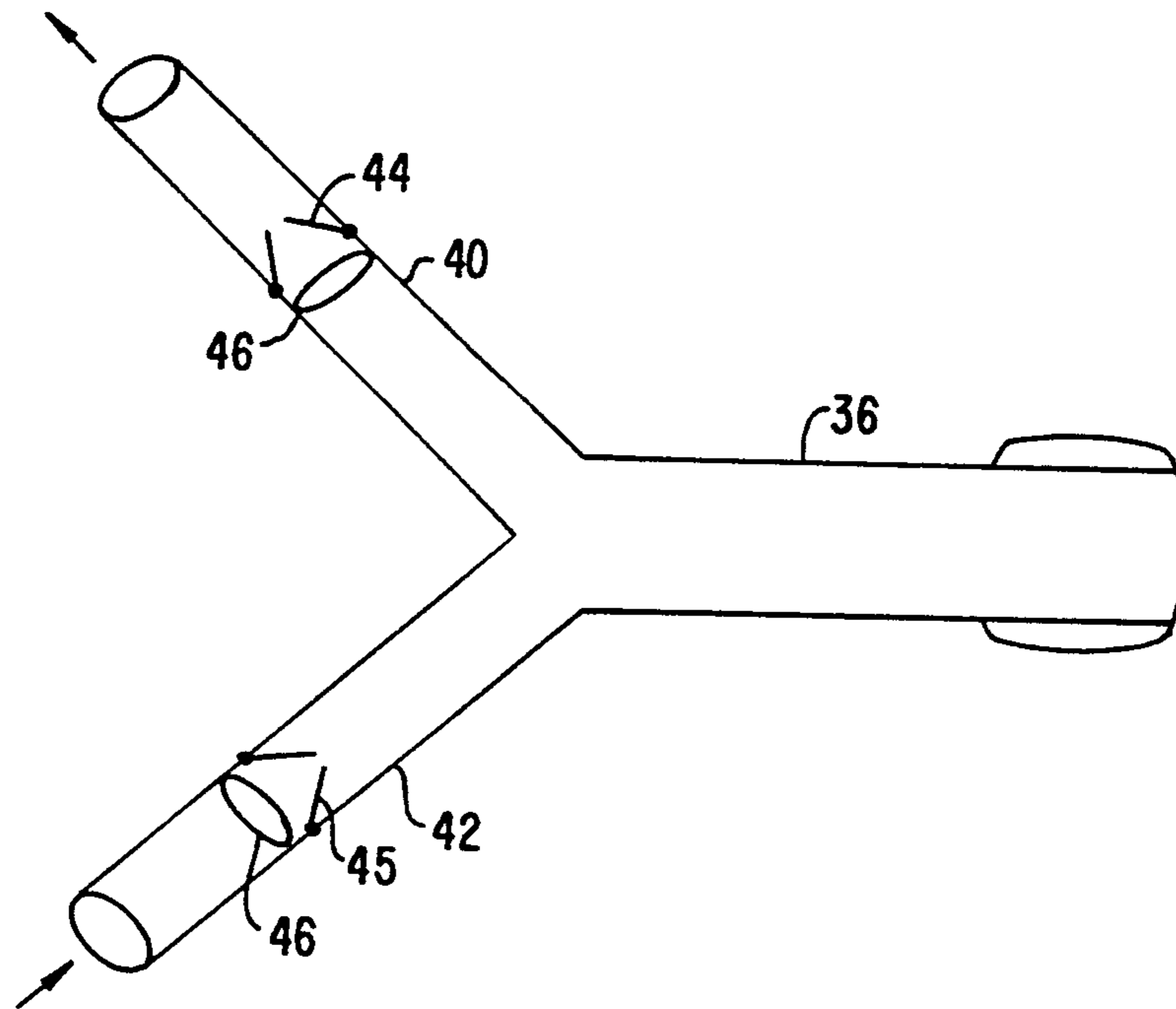


FIG. 4A.

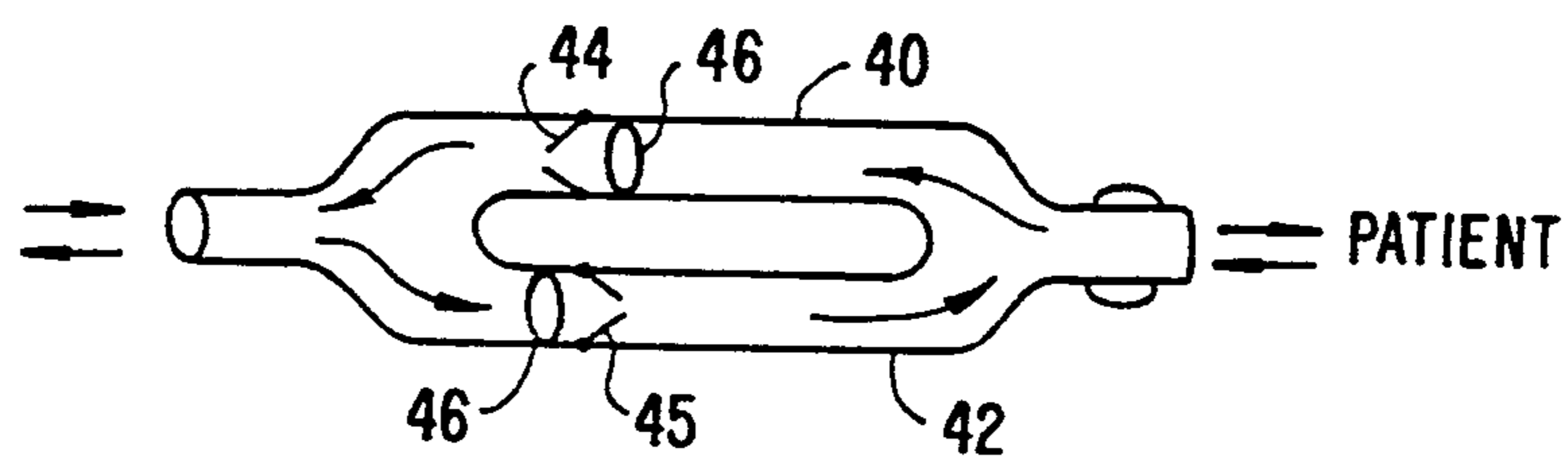


FIG. 4B.

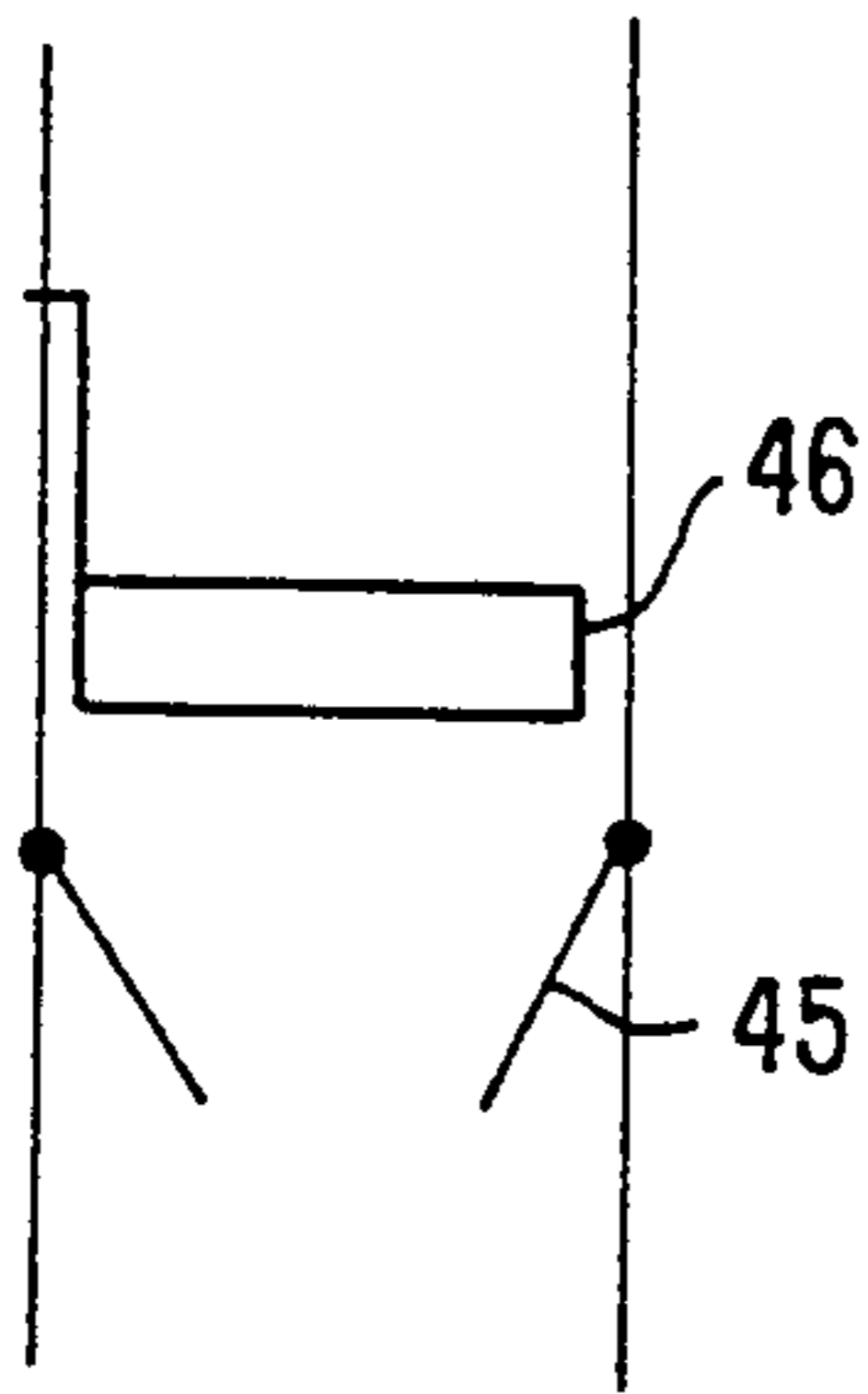


FIG. 5A.

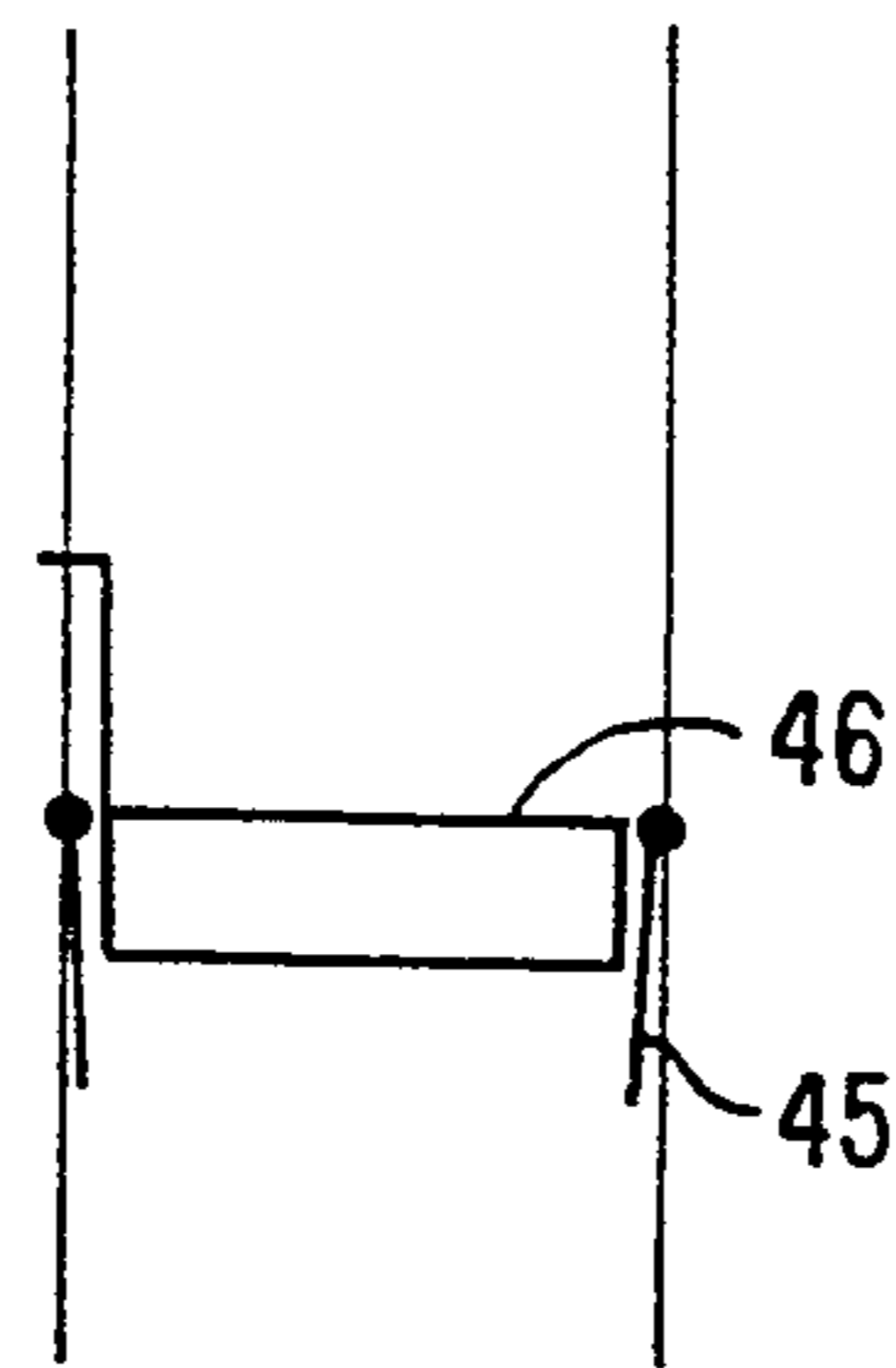


FIG. 5B.

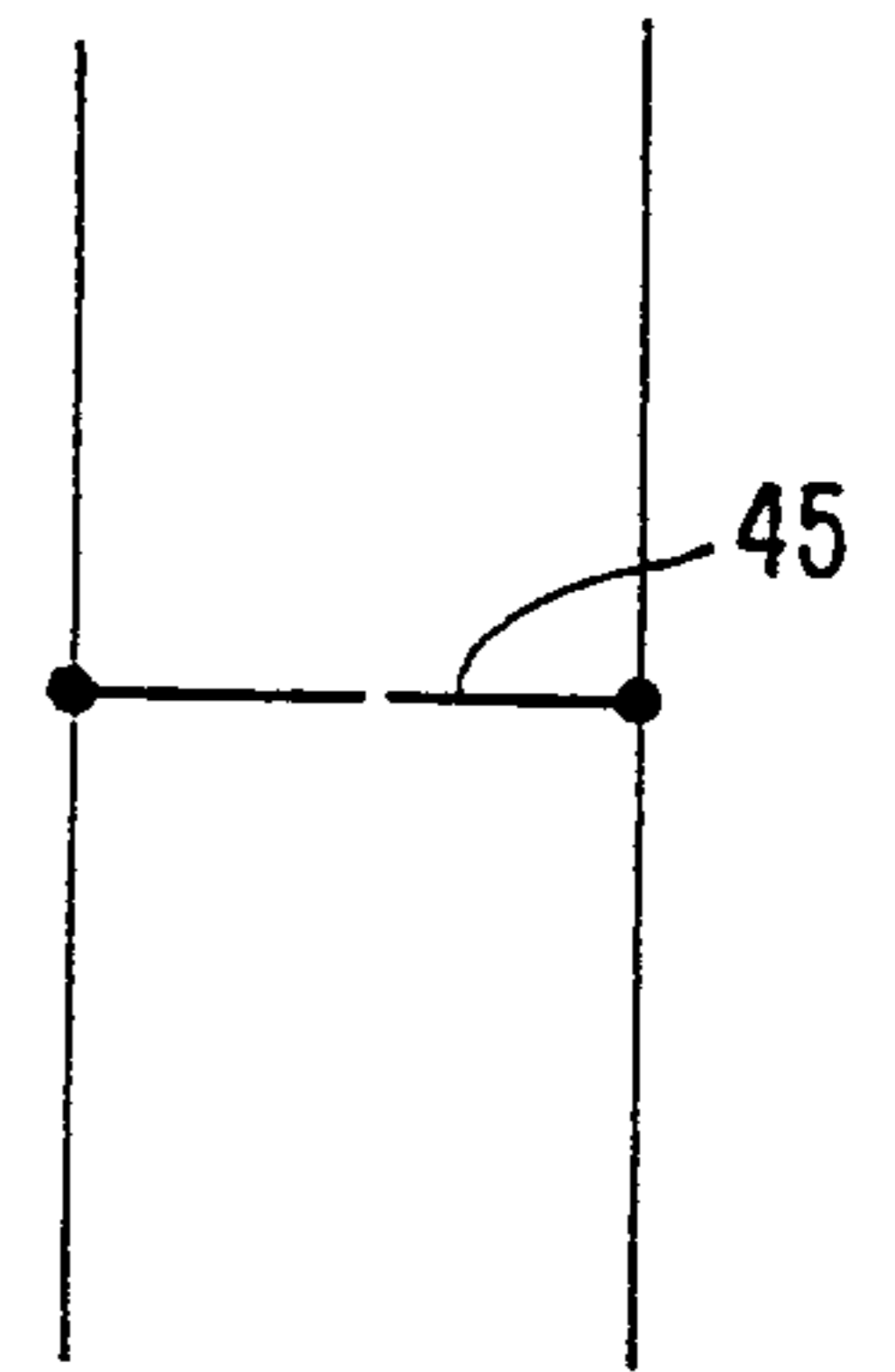


FIG. 5C.

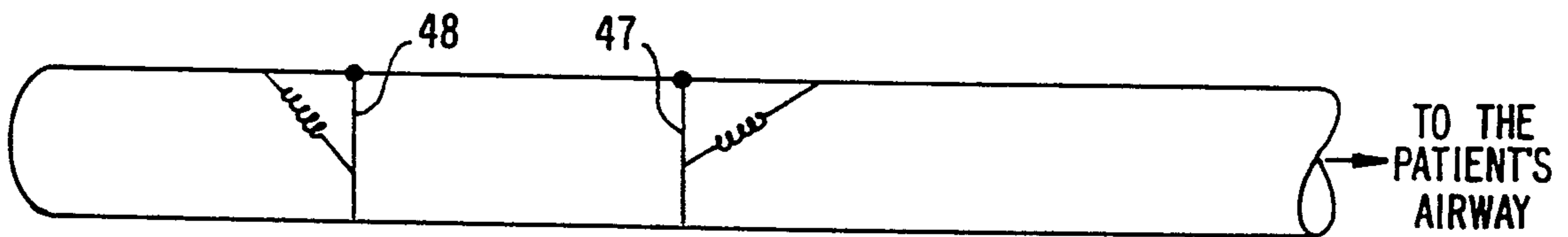


FIG. 6A.

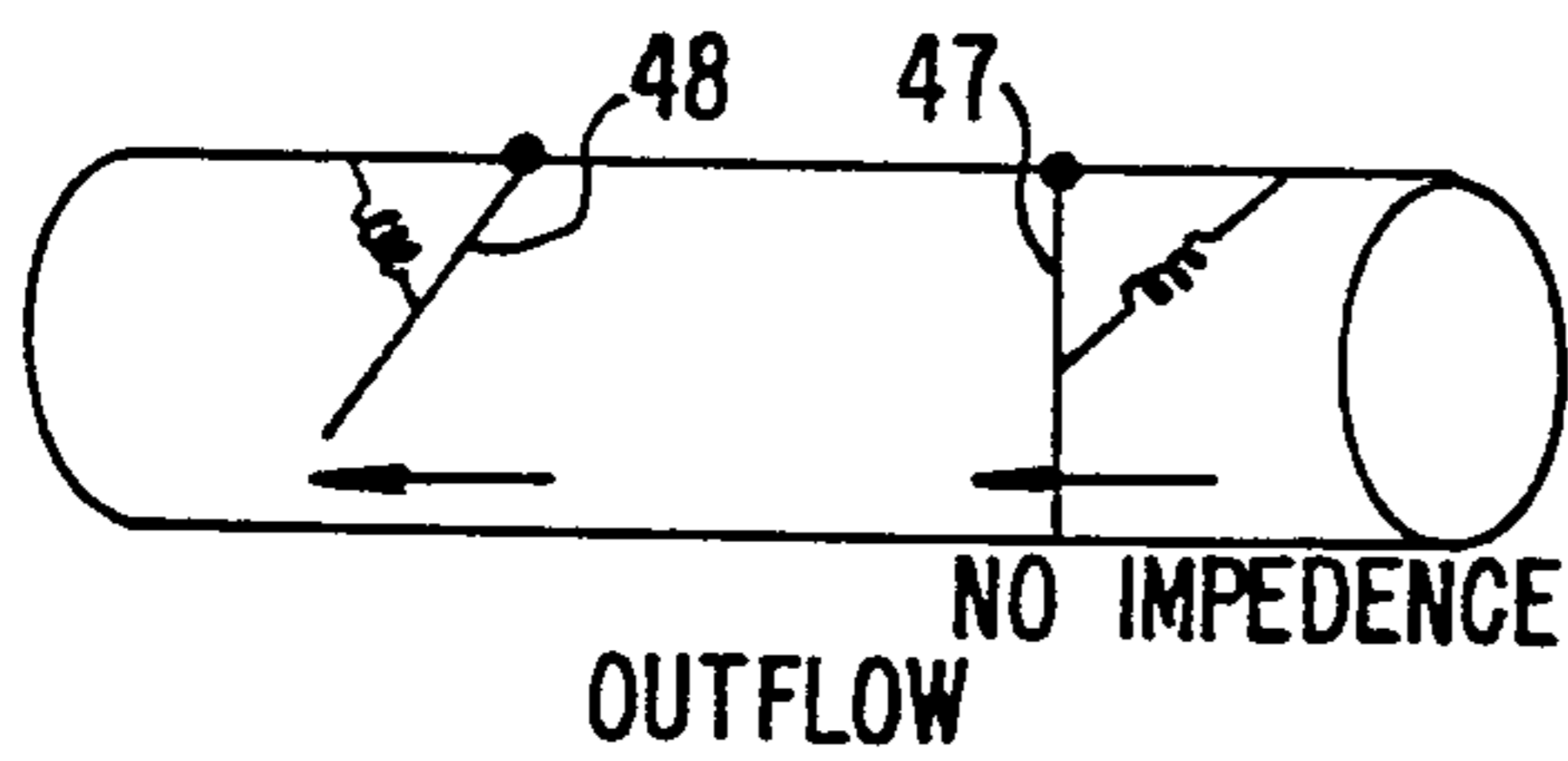


FIG. 6B.

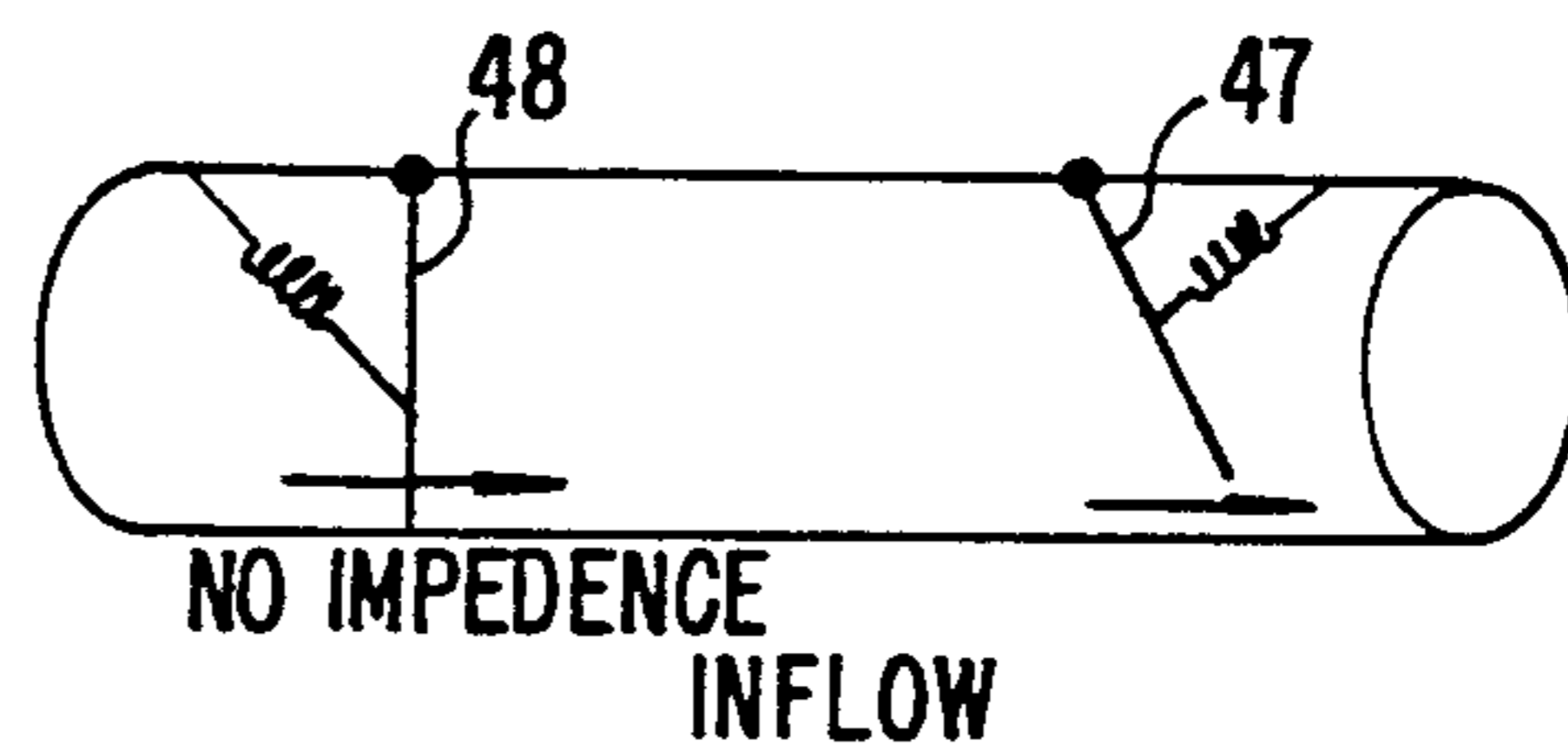


FIG. 6C.

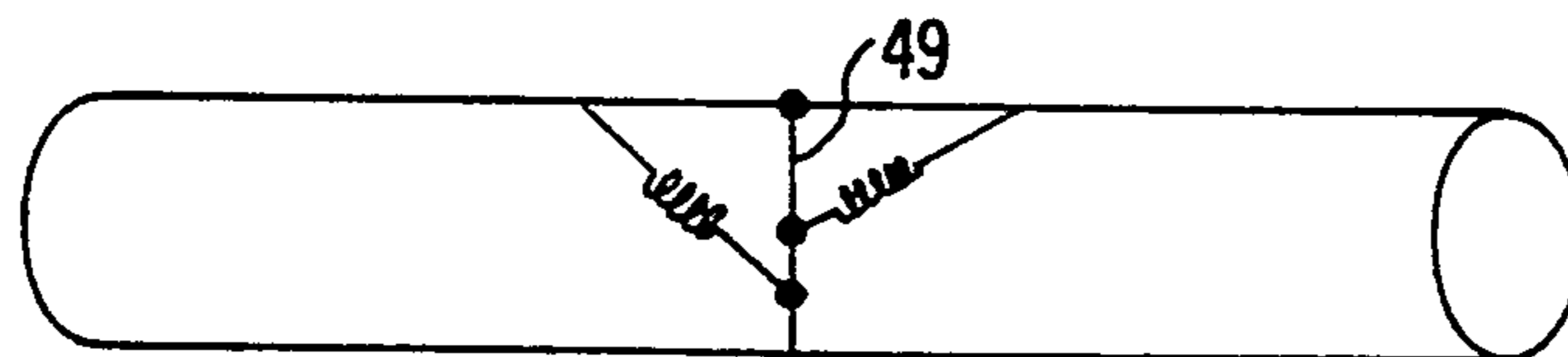
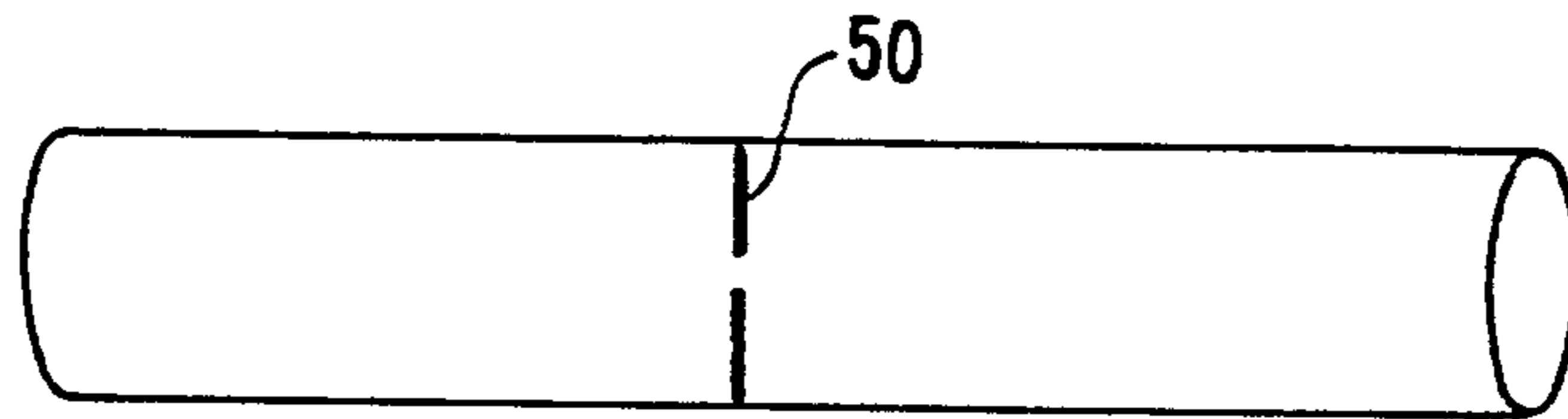
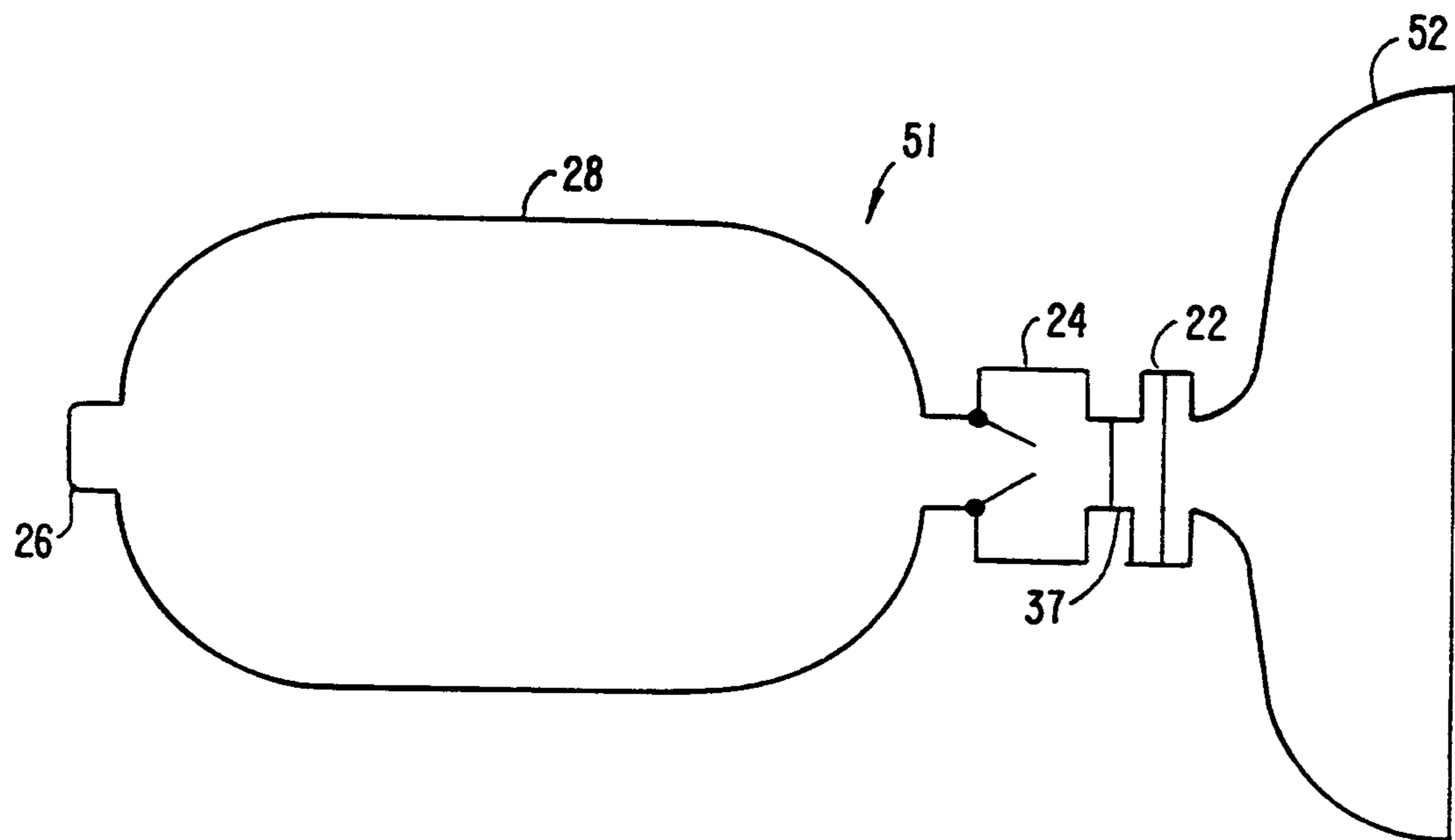


FIG. 7.

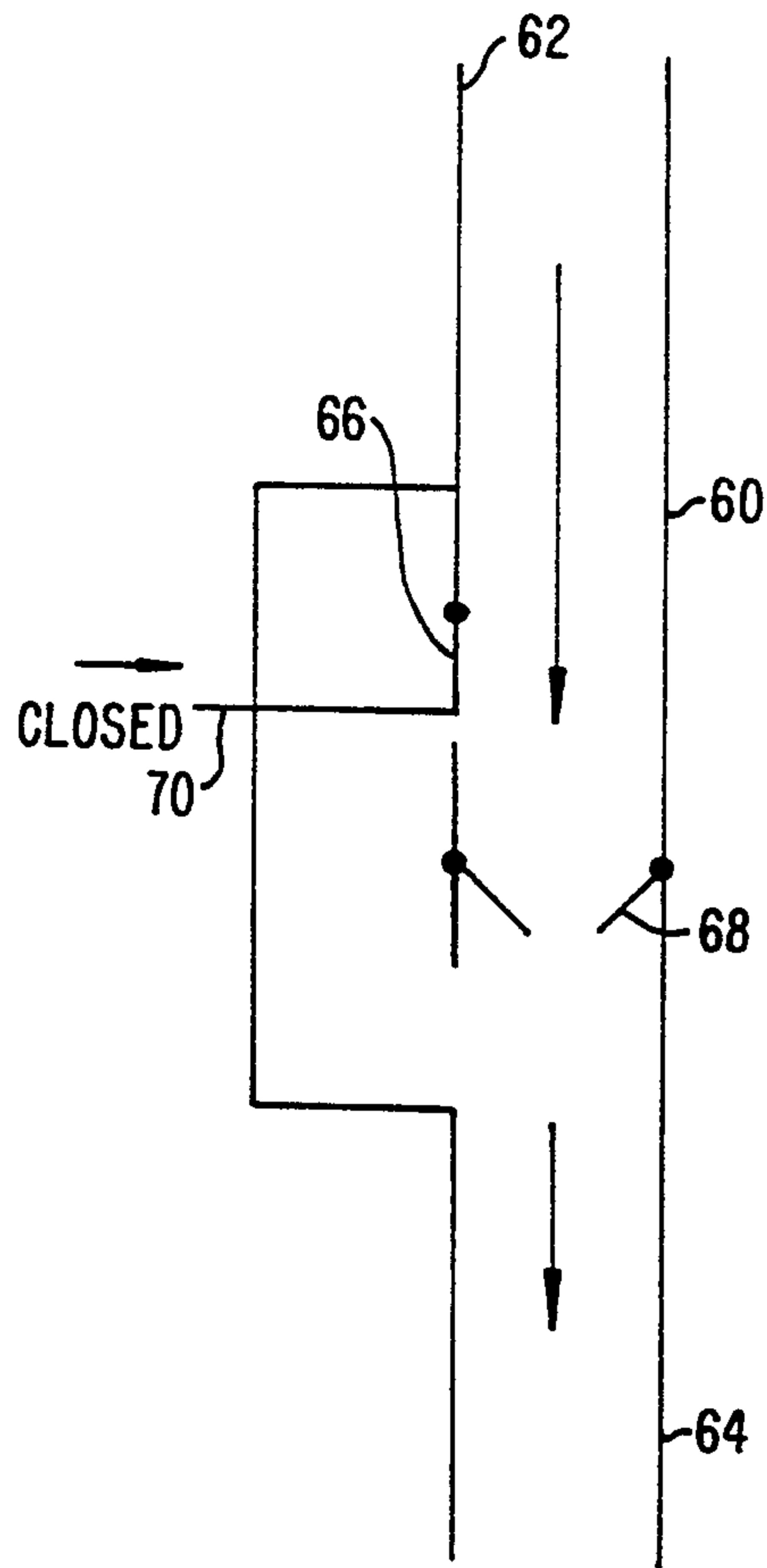
4/11



**FIG. 8.**

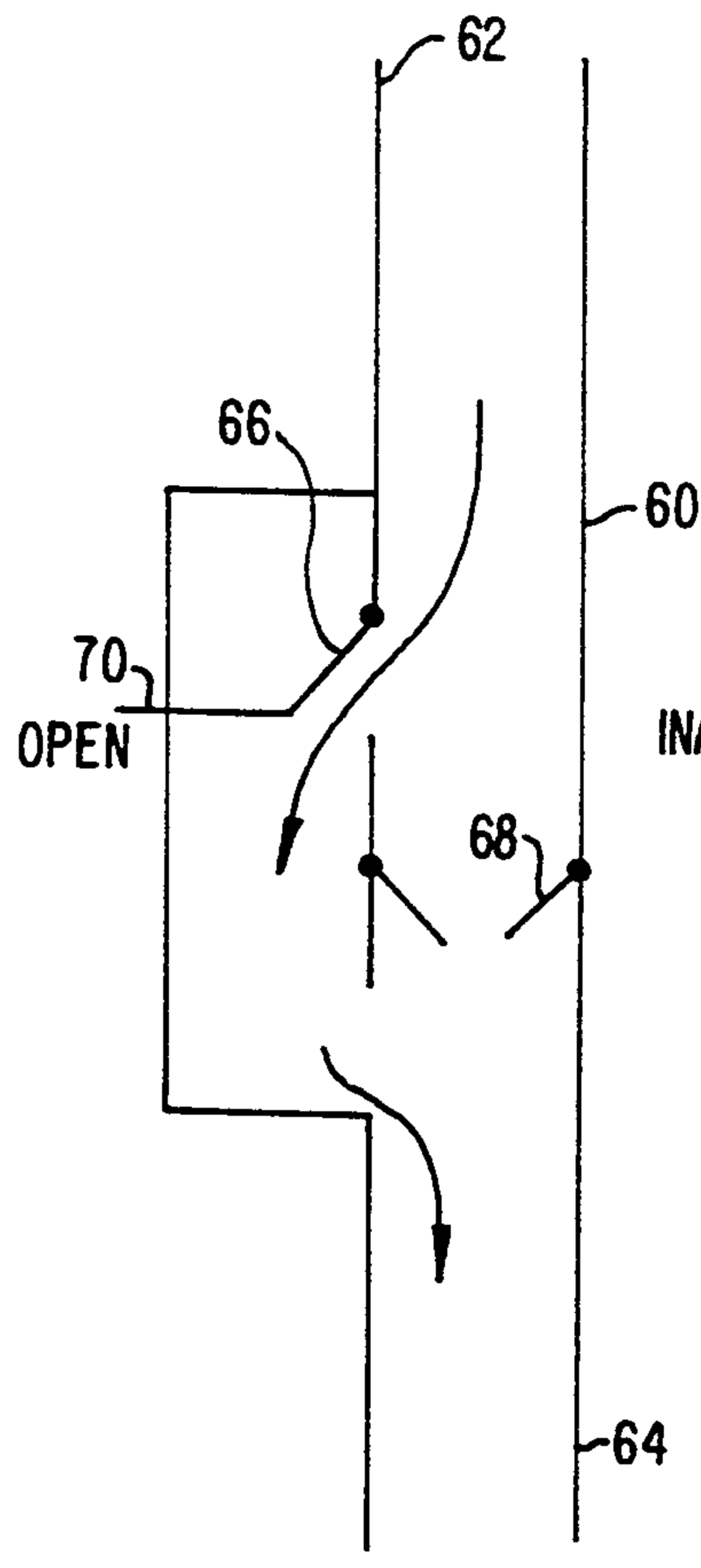


**FIG. 9.**



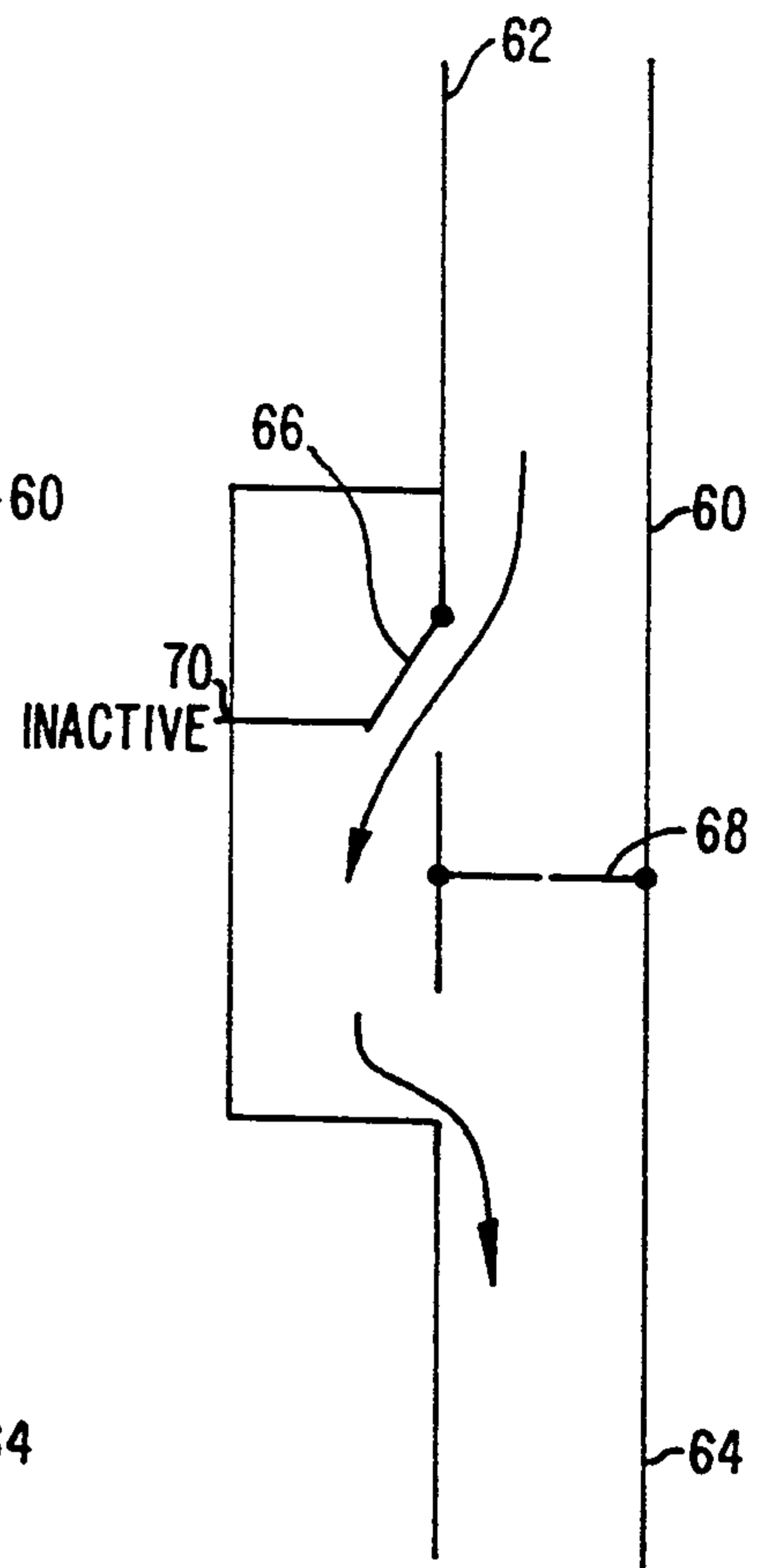
PATIENT

FIG. 10A.



PATIENT

FIG. 10B.



PATIENT

FIG. 10C.



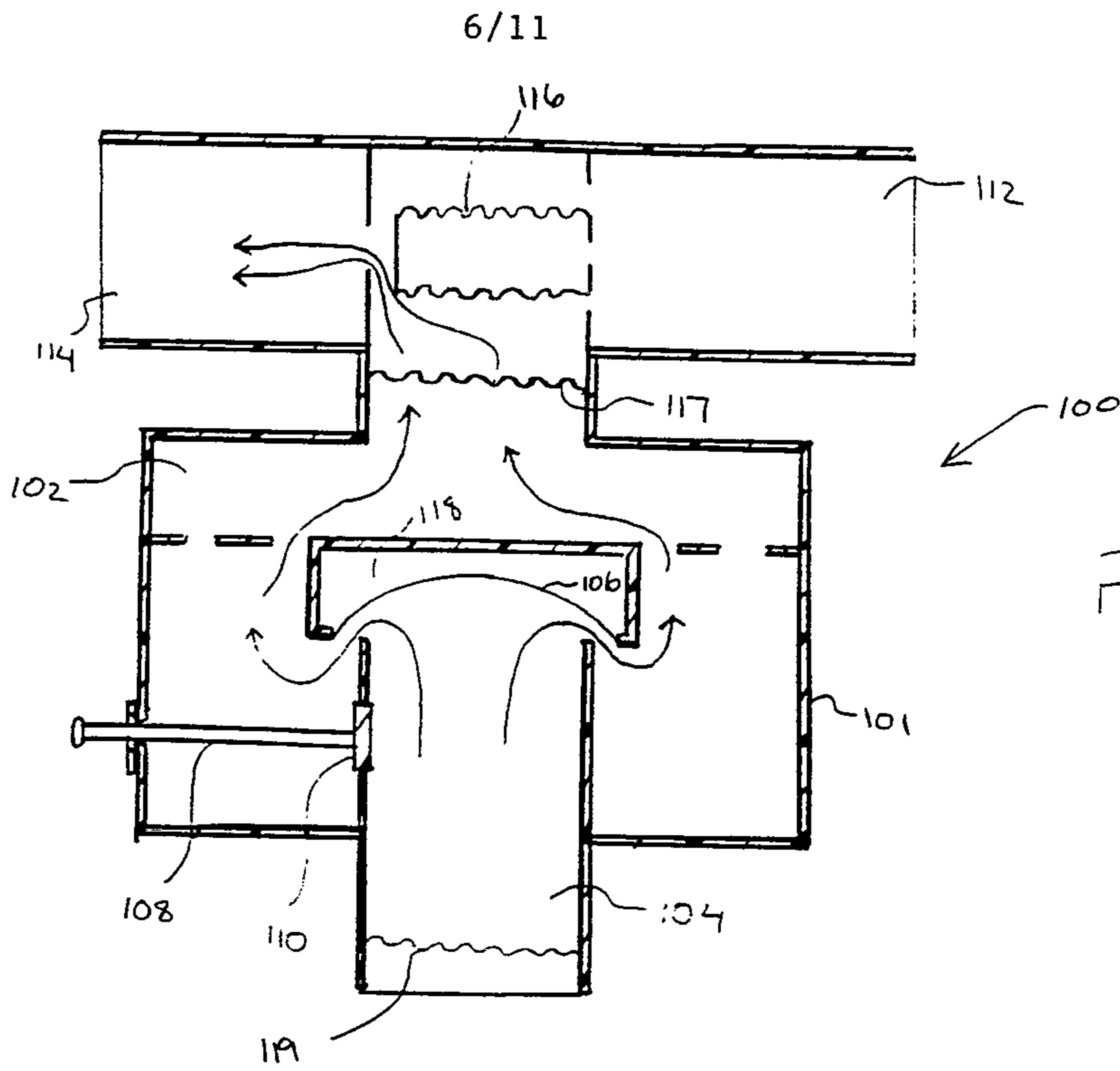


FIG 11

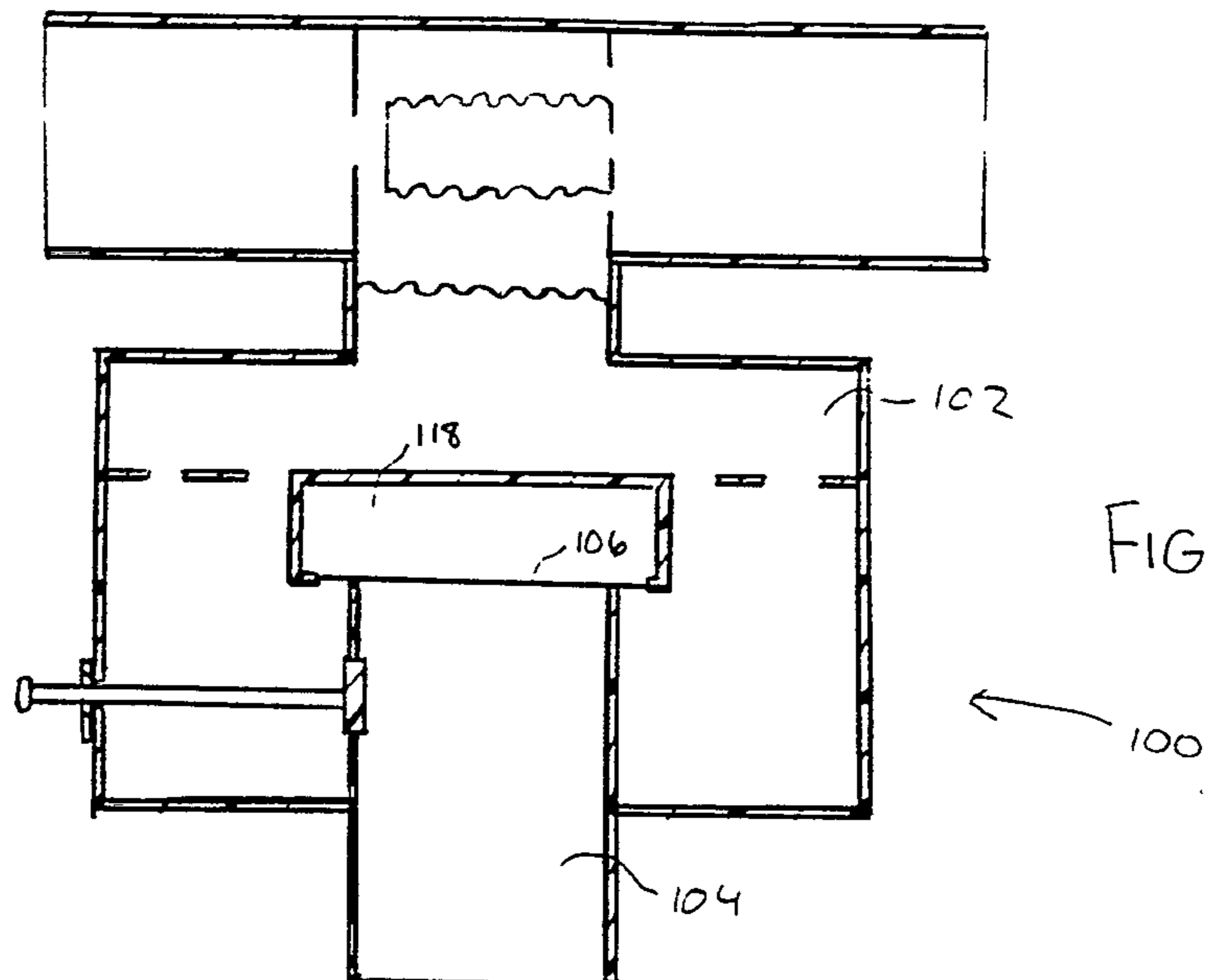


FIG 12

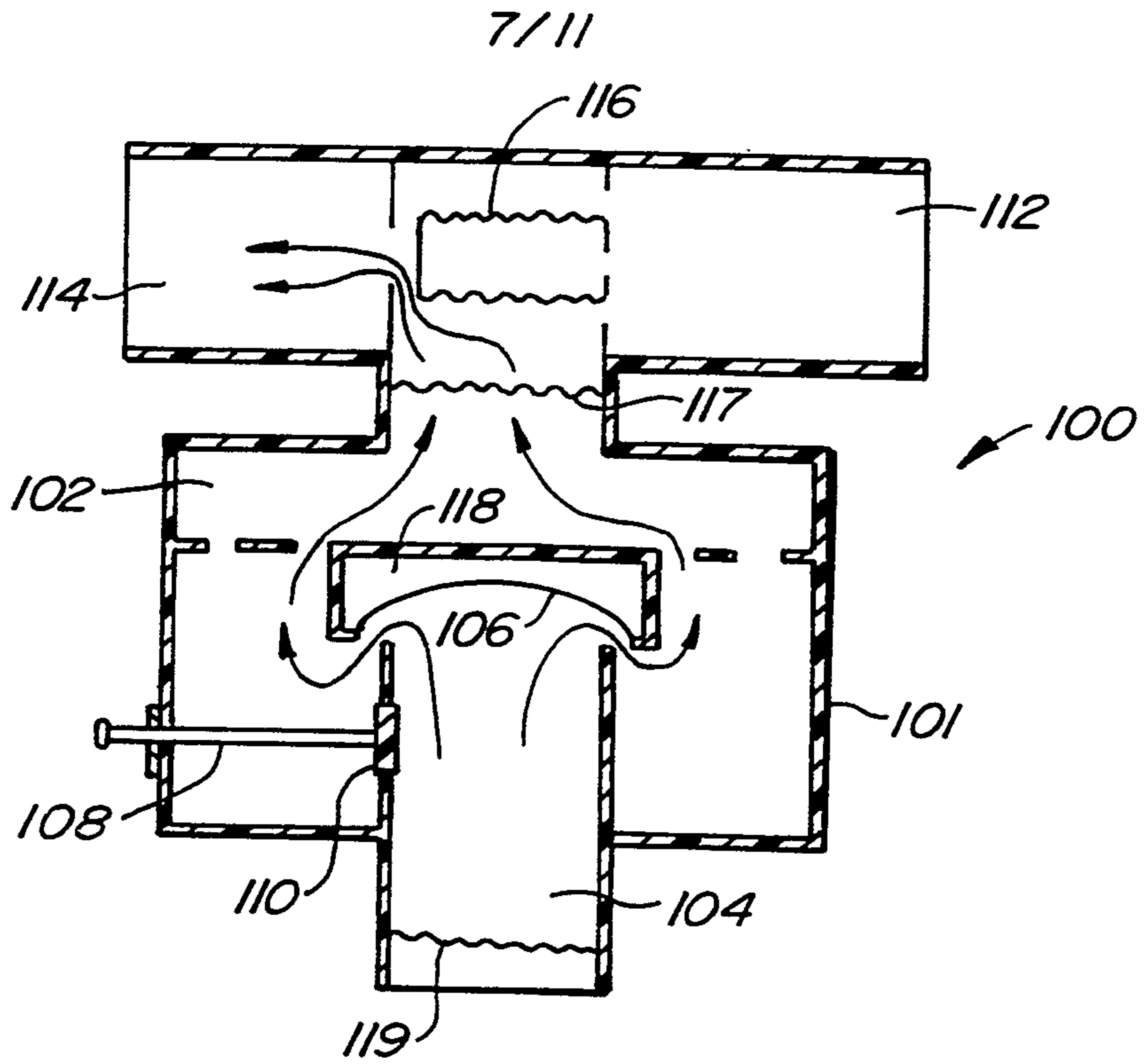


FIG. 11.

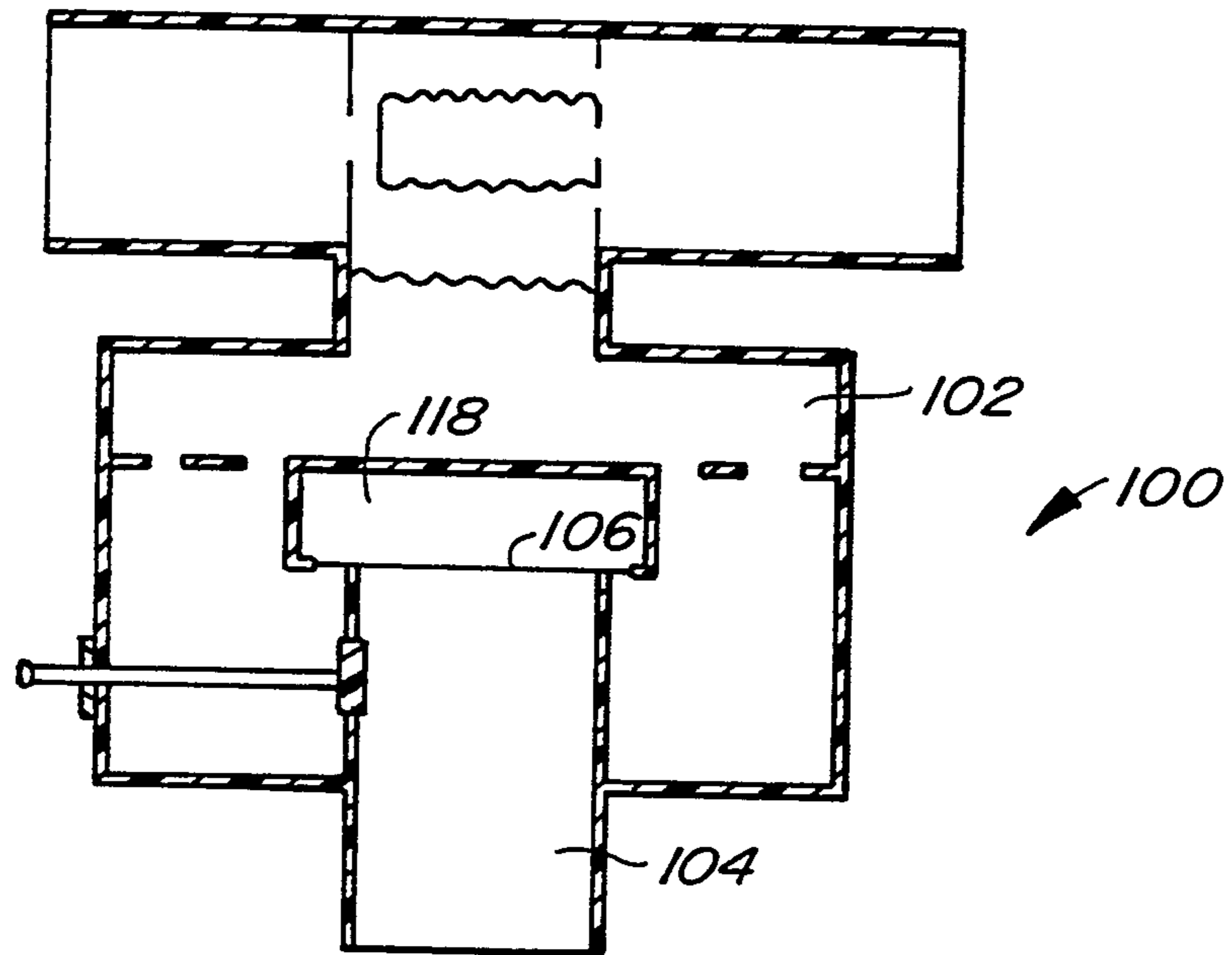


FIG. 12.

8/11

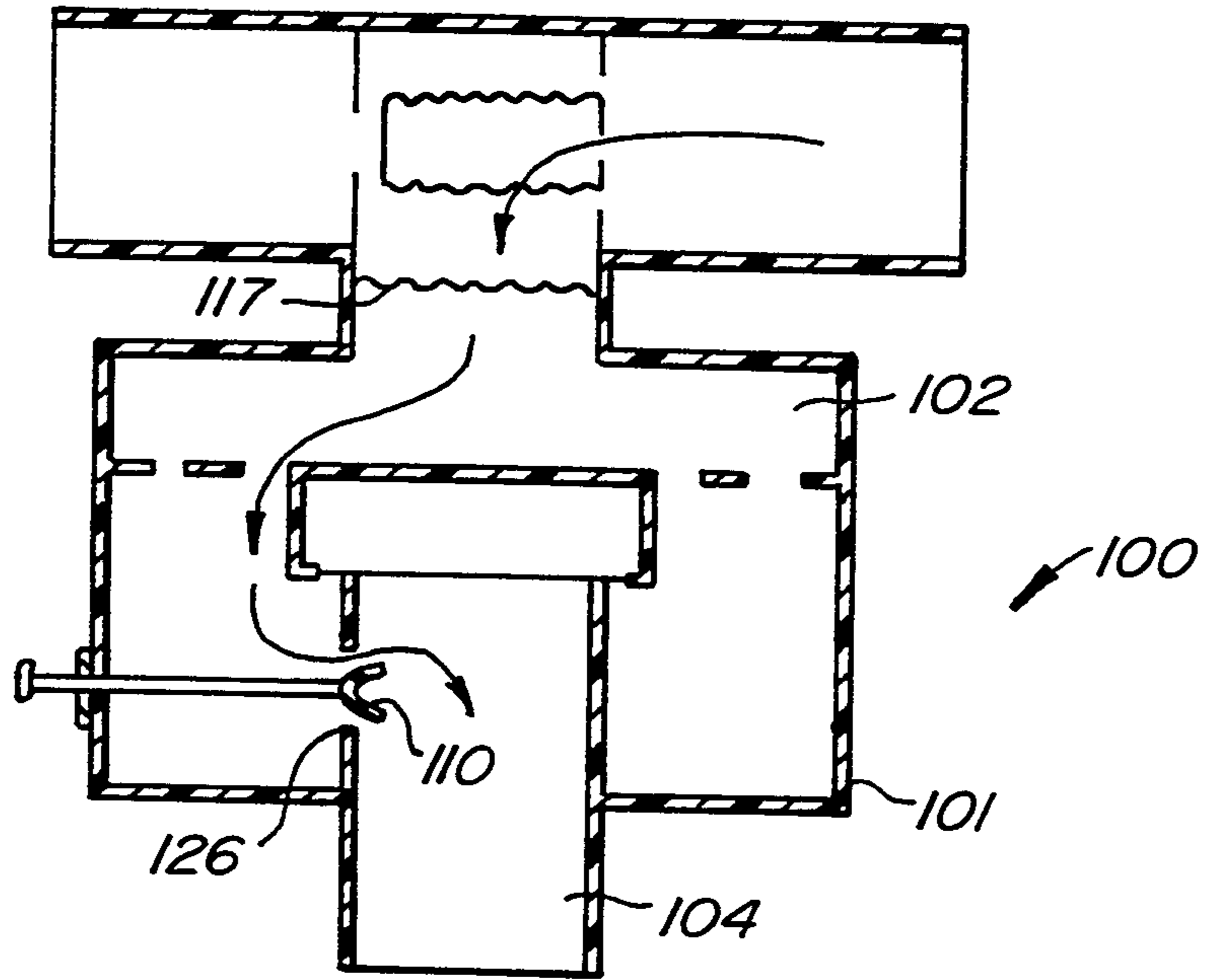


FIG. 13.

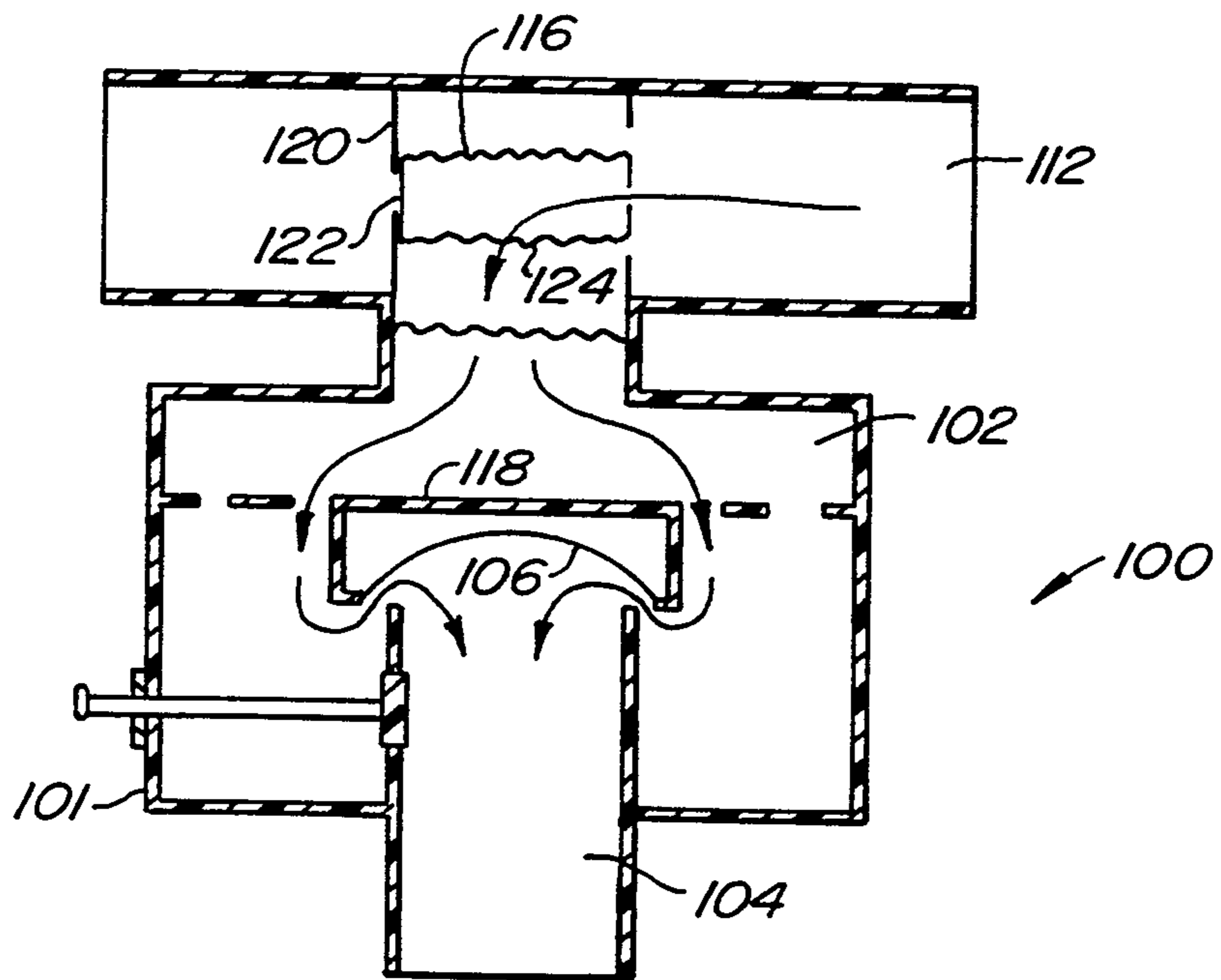


FIG. 14.

9/11

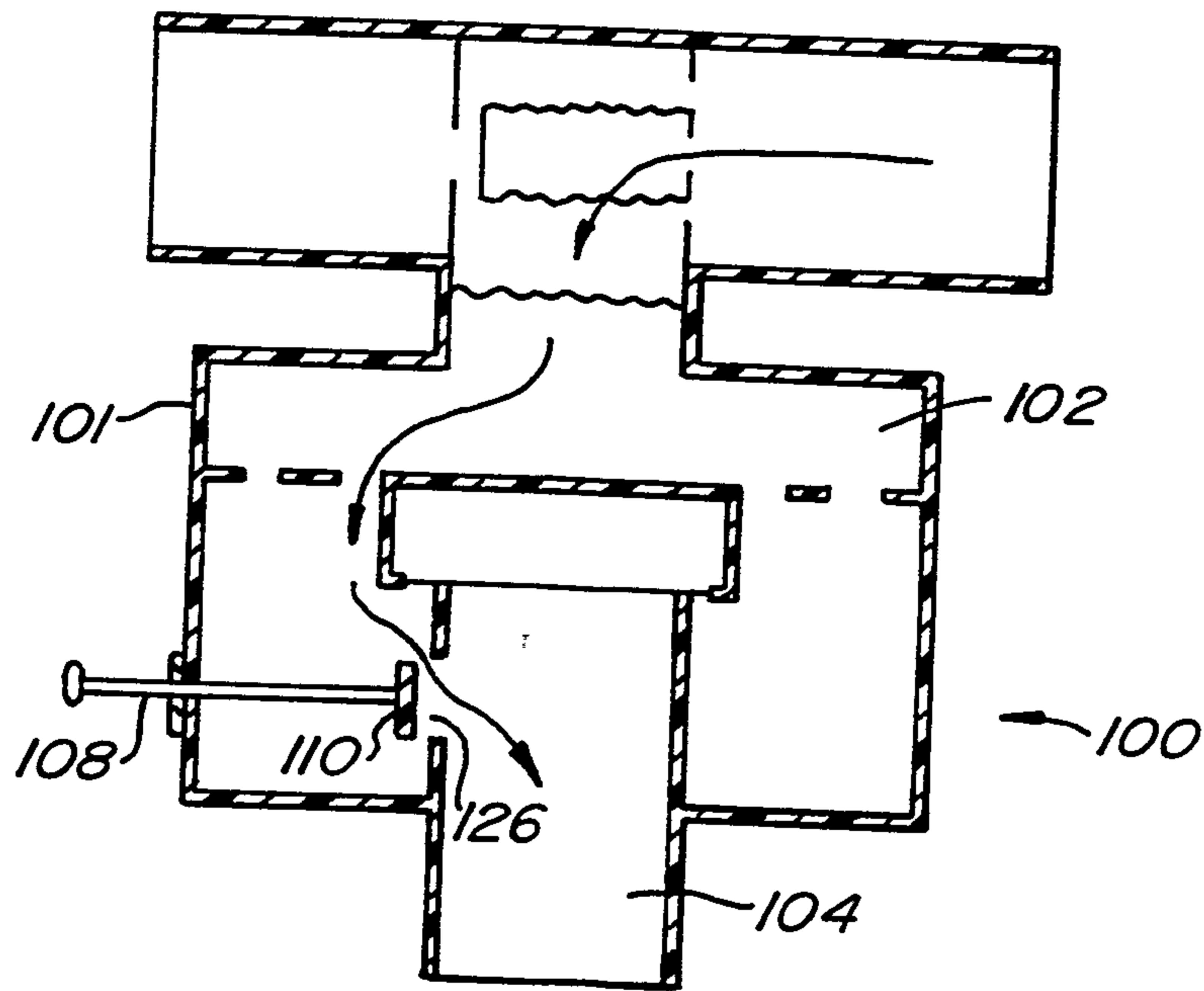


FIG. 15.

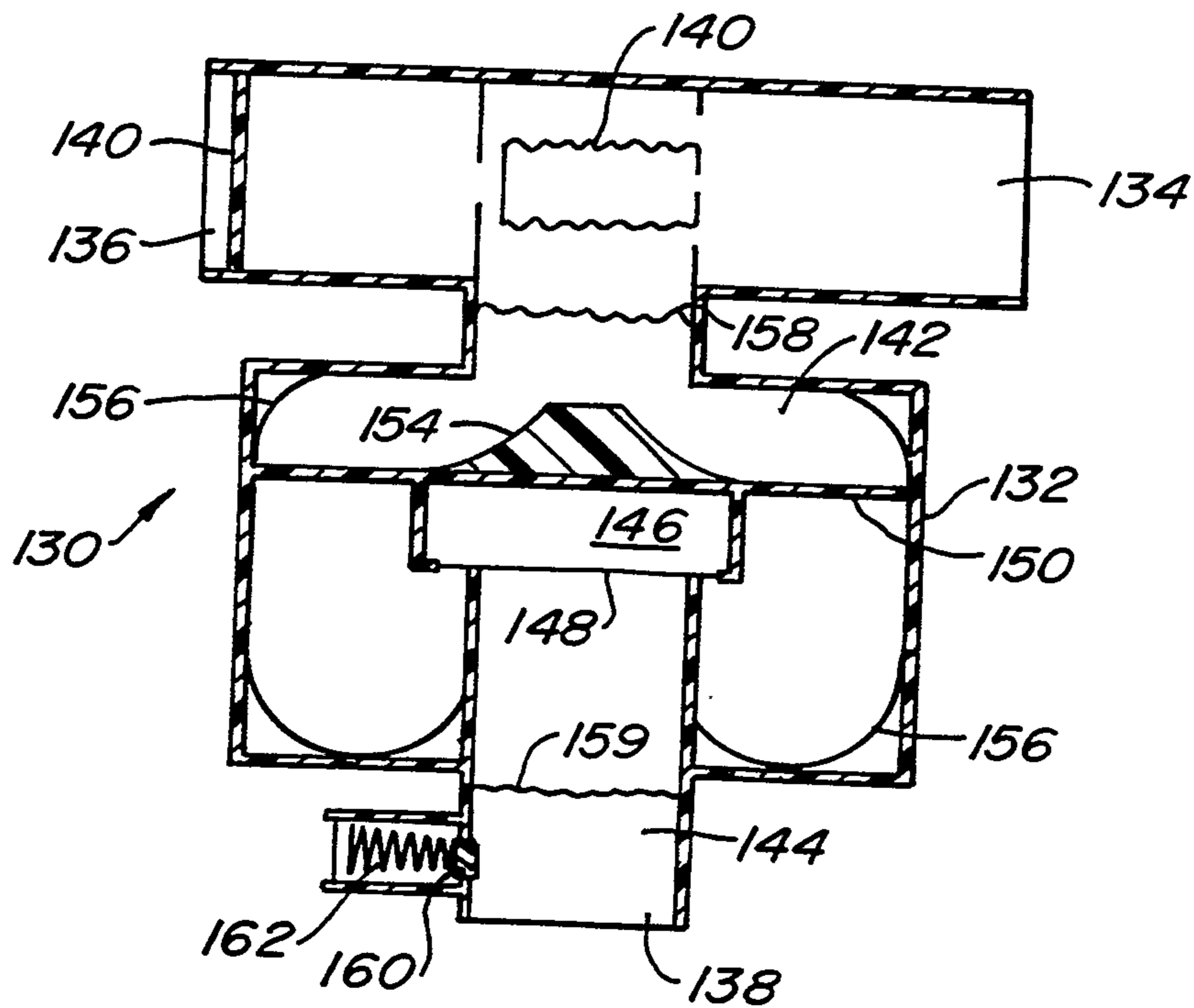


FIG. 16A.

10/11

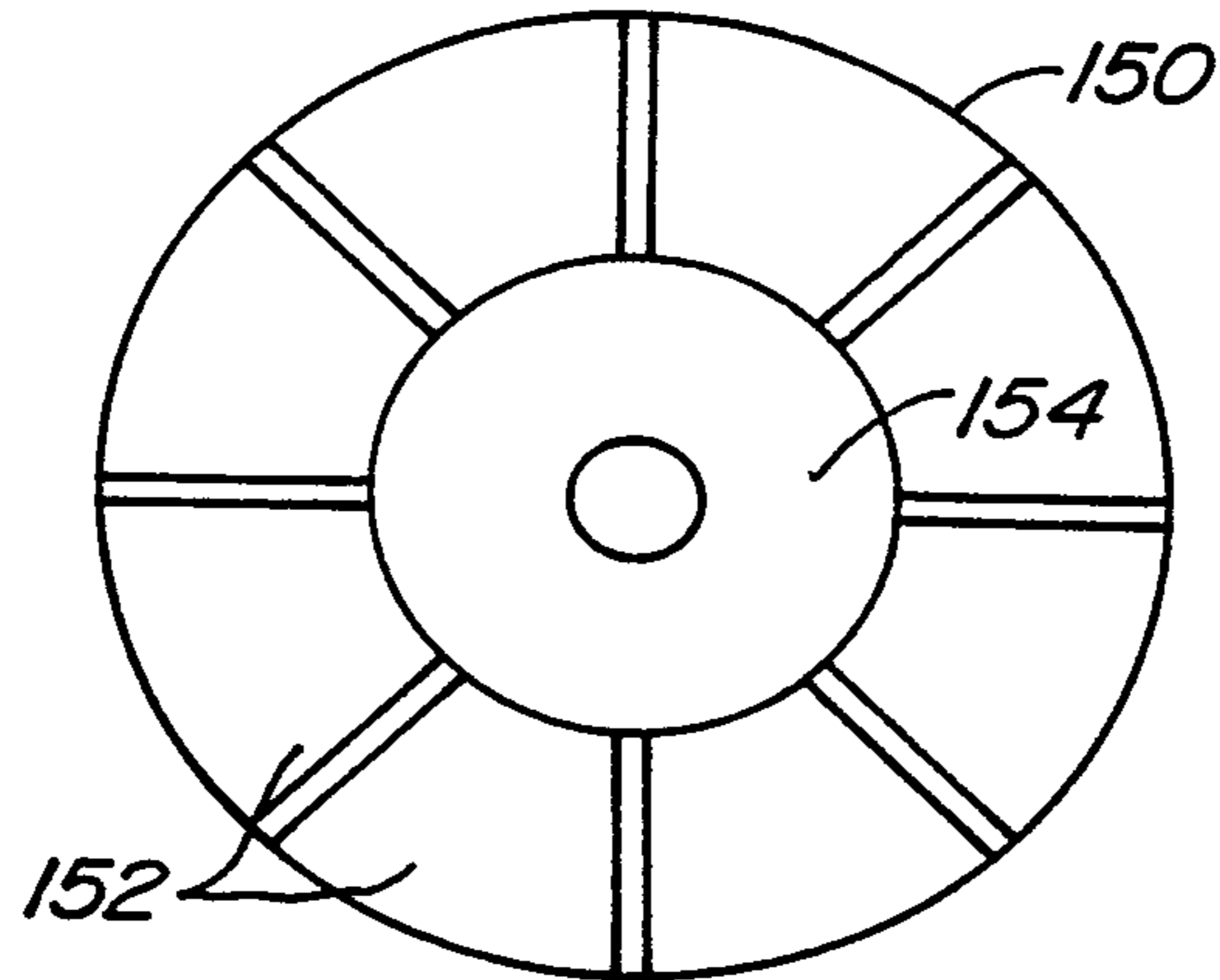


FIG. 16B.

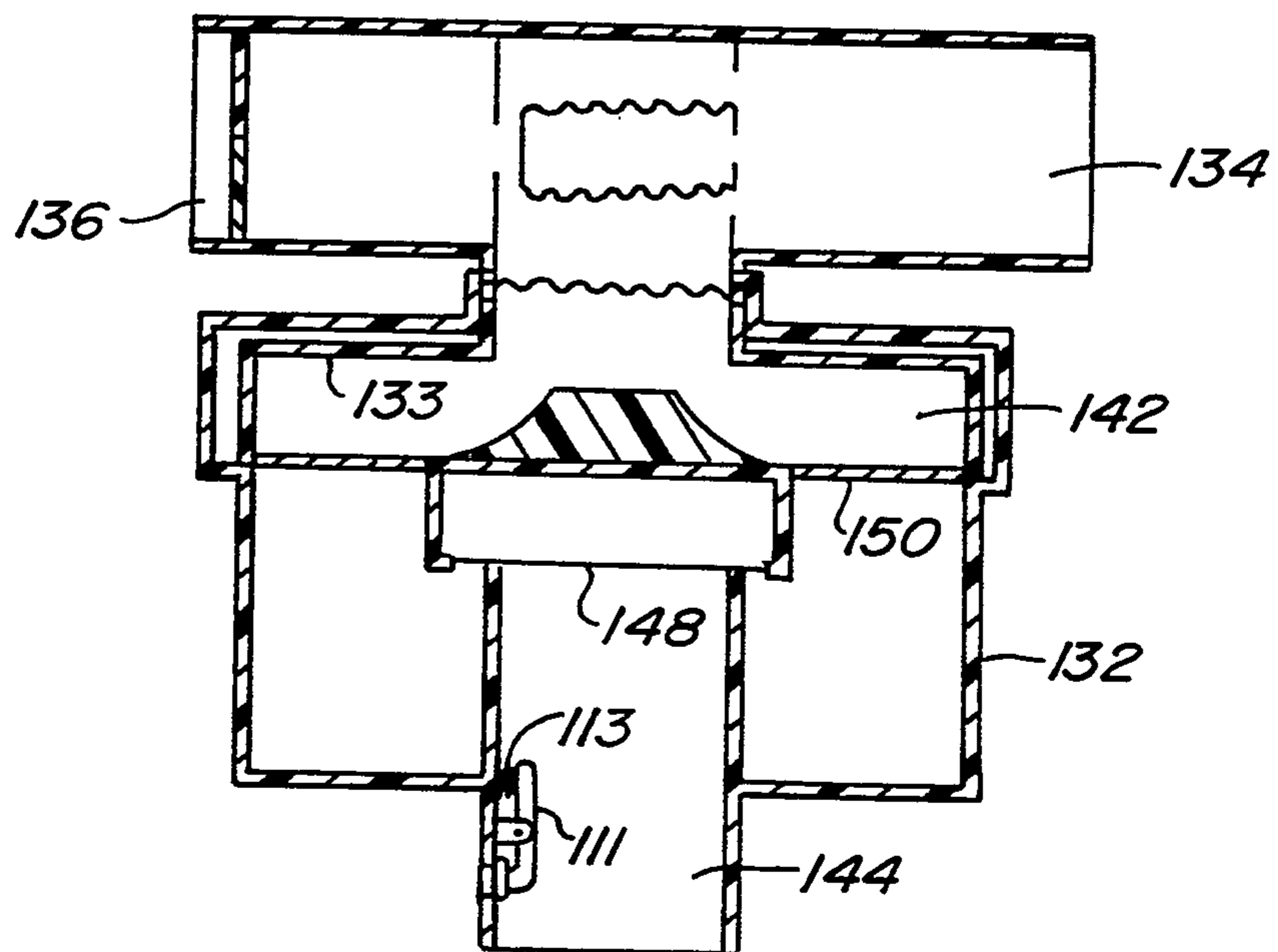


FIG. 16C.

11/11

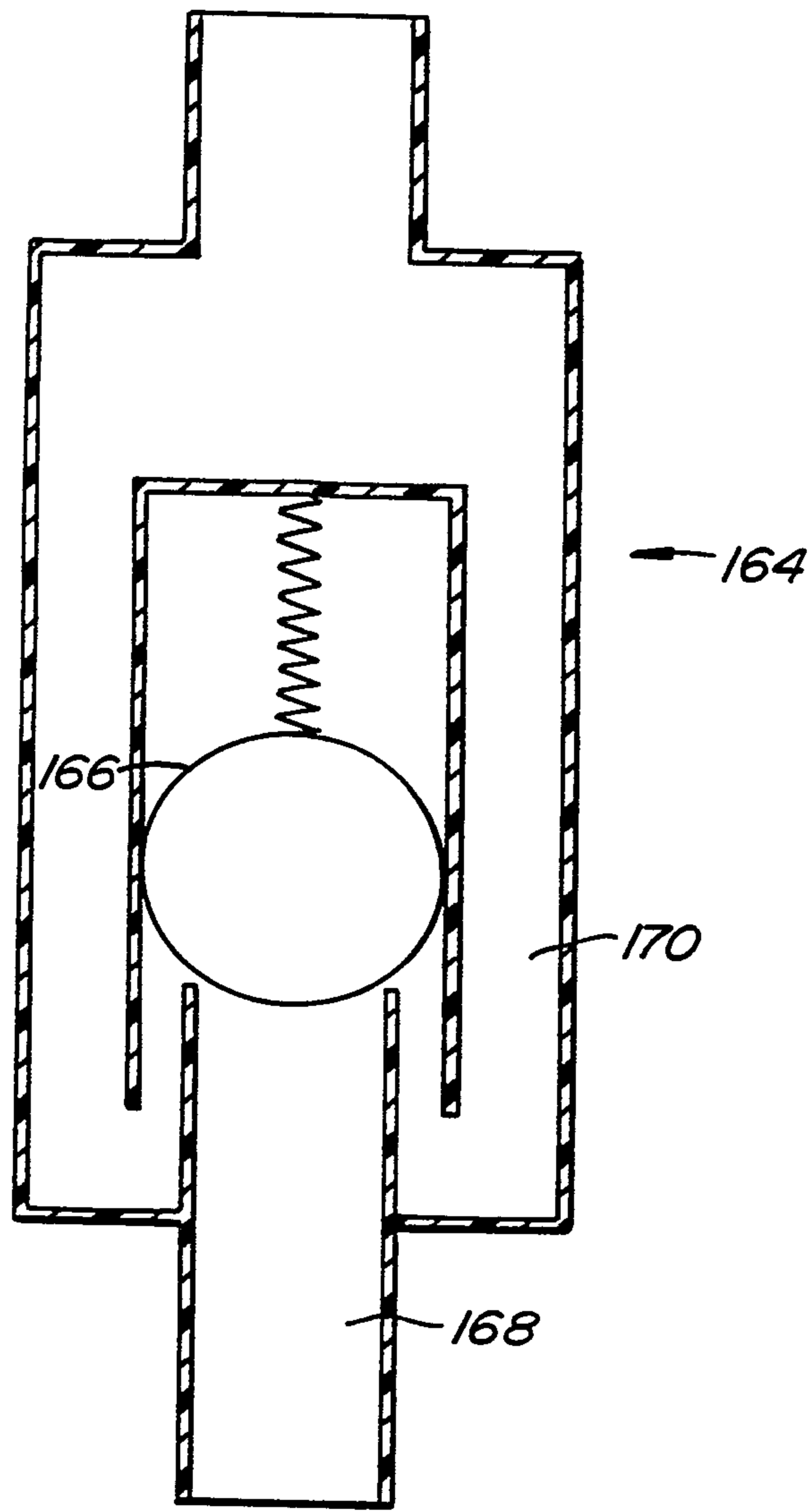


FIG. 17.

