

G. CROMPTON.

DEVICES FOR FINDING THE TRUE SHED IN LOOMS.

No. 173,594.

Patented Feb. 15, 1876.

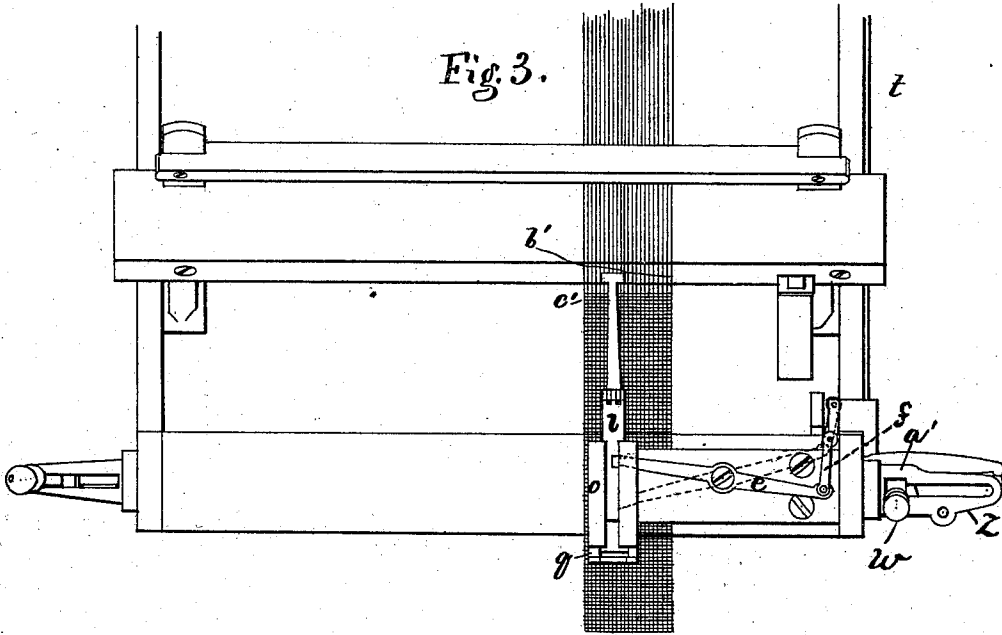
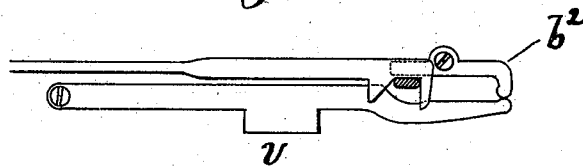

Fig. 4.



Witnesses:

L. H. Catimer.

W. J. Pratt.

Inventor.

George Crompton
per Coosby Gregory Atlys.

UNITED STATES PATENT OFFICE.

GEORGE CROMPTON, OF WORCESTER, MASSACHUSETTS.

IMPROVEMENT IN DEVICES FOR FINDING THE TRUE SHED IN LOOMS.

Specification forming part of Letters Patent No. 173,594, dated February 15, 1876; application filed October 26, 1875.

To all whom it may concern:

Be it known that I, GEORGE CROMPTON, of Worcester, in the county of Worcester and State of Massachusetts, have invented an Improved Loom, of which the following is a specification:

In weaving, when the shuttle-thread breaks or runs out, or an imperfection in weaving occurs, it often happens that the crank-shaft and pattern devices continue to move and make one or more sheds before the loom can be stopped, and then the pattern or the pattern and shuttle-box mechanisms are turned back until the true shed is formed, so that the shuttle-thread may be mended or replaced in the true shed, to continue the pattern properly. This has been done both by hand and by power.

This invention relates to a simple mechanism for finding the true shed. The true shed may be found by allowing the loom to run forward as usual, and when found the loom is stopped automatically.

This invention consists in a new method of finding and indicating a true shed, or the shed in which a certain weft was woven, and for this purpose I employ a fork adapted to be inserted behind the weft last woven across the warp, or between a last-woven pick or weft extending across the warps and an adjacent weft constituting a part of the properly-woven fabric. The fork rests against the weft, in front of it, so long as that weft is held by crossed warps; but when the true shed, or one corresponding with the shed in which the weft in front of the fork was laid, is reached, the weft no longer being held by crossed warps, the fork is pressed forward and the weft is thrown forward into the open shed. With a fork adapted to operate in this way I have connected devices for releasing the shipper-lever, which, through the action of any well-known devices, will stop the loom.

Figure 1 is a longitudinal section of a loom embodying my invention. Fig. 2 is a front view of the breast-beam and the parts carried by it. Fig. 3 is a top view, showing the operation of the fork when being used to find a true shed; and Fig. 4, a view of the shipper-lever connection on the under side of the breast-beam.

The loom-frame *a* and lay *b* are of any suit-

able or known construction. Connected with the breast-beam *c*, or with the support *d* thereon, is a lever, *e*, connected at one end, through a link, *f*, with a pivoted vertical lever, *g*, having a tendency, by the action of a weight, *h*, or by a spring, to move at its lower end toward the lay *b*. This lever *g* is connected, by means of a loop, *i*, or fingers or projections, with a radius-bar, *j*, connected at its upper end with a pivoted arm, *k*. The end of the lever *e* toward the center of the breast-beam is connected with the shank of and adapted to move the shed-finding fork. This shed-finding fork consists of a shank, *l*, and an arm, *m*, with teeth *r*—one or more—the shank *l* being suitably guided in this instance by the stand *o* projecting from the support *d*. The stand *o* has a projection, *p*, and near its lower end is a passage, *q*, for the reception of the head *r* of the fork, when the latter is held by the support and stand out of operation. In this instance the arm *m* of the fork is pivoted so that it may be turned back in the direction of the arrow, when the head *r* enters slot *q*, and in such position the lever *e*, Fig. 3, holds back the lower end of the weighted lever *g*, (see Fig. 1,) which, through its connection, holds the radius-bar *j* back in such position that the end *s* of vibrating lever *t*, actuated by a cam, *u*, on the crank-shaft, cannot engage *j*, and arm *k* will remain down. Pivoted to the lay is a dagger, *x*. It projects forward toward the breast-beam, and, when not lifted positively by the lever *k*, (put in operation by the lever *t*, through the radius-bar *j*,) the dagger will pass under the releasing-bar *v* of the shipper-handle *w*. The guide in which the shipper-handle *w* works is a bracket, *z*, provided with a shipper-holding notch, *a'*, and under the guide is a pivoted finger, *b'*, adapted at one end to meet the releasing-bar, so that the latter, when moved by the dagger *x*, will release the shipper-handle from its holding-notch *a'*. When the loom is operating regularly the arm *m* of the fork is folded back, so that the head *r* is caught and held in the notch *q*, and the levers *e g* are held in the dotted position shown in Figs. 1 and 3, the end of the radius-bar being out of the path of the end *s* of vibrating lever *t*.

Should a weft break or run out, it is necessary, in order to preserve the pattern, to insert

the mended or renewed weft in the shed where the fault occurred; and to find the true shed, which may have been changed several times, the fork is turned over to the position shown in Figs. 1 and 3, and the tines *n* are inserted between the broken weft *b'* and the adjacent weft, or the broken weft may be removed, and then the fork is inserted between the two last properly-laid picks of weft of the woven fabric *c'*. The fork, when so inserted, is kept pressed backward, so as to keep the weighted lever and radius-bar *j* in the position shown in dotted lines, Fig. 1.

The lay continues to operate all as usual, and the reed beats this filling up at each stroke and confines the tines *n* between the two adjacent wefts. The weft, acting against these tines, holds the fork back so long as sheds are formed in which crossing-warps hold the weft, but when the true shed is reached the weft, being no longer held, will allow the fork to move forward under the action of the weight *h* or a spring, and this movement will push the weft out into the open shed, and at the same time the radius-bar *j* will be moved forward. At this time the parts will be as represented in full lines, Figs. 1 and 2, and the movement of lever *t* will raise bar *j* and bar *k*, so that, as the lay moves forward, the dagger *x* will be lifted and will engage the releasing-lever *v* and stop the loom.

This fork would operate equally as well with a loom having its motions reversed and run backward to find a true shed rather than run forward, as herein described; but I prefer to run the loom forward.

A shipper-handle is placed at each side of the loom, and they are connected, as usual, by

a forked rod. I may hold this fork to operate in the manner described by other means than the holder shown.

This shed-finding fork is not to be used as an ordinary weft-fork; is brought into action only when it is desired to find a true shed; at all other times it being held out of action.

I claim—

1. The method of finding and indicating a true shed in a warp being woven, substantially as described, which consists in holding the weft last laid or woven pressed forward in opposition to the blows of the reed, by means of a fork that presses against the weft, as the warps are opened, until the true shed is reached, when the fork projects the weft out from its locked position into the opened true shed.

2. The shed-finding fork, in combination with its stand, and mechanism to retain the fork in its backward position, except at the time the true shed is being found, substantially as described.

3. The shed-finding fork, lever *e*, and link *f*, in combination with a lever adapted to press the fork forward or toward the reed, and a belt-shipping mechanism, substantially as described.

4. The lever *g*, controlled by the shed-finding fork, bar *j*, arm *k*, and lever *t*, in combination with the dagger, releasing-lever and shipper *w*, substantially as described.

In testimony whereof I have signed my name to this specification in the presence of two subscribing witnesses.

GEO. CROMPTON.

Witnesses:

J. B. SYME,
J. A. WARE.