

(19) World Intellectual Property Organization  
International Bureau



(43) International Publication Date  
6 March 2008 (06.03.2008)

PCT

(10) International Publication Number  
**WO 2008/027930 A2**

- (51) International Patent Classification:  
**G02F 1/01** (2006.01)
- (21) International Application Number:  
PCT/US2007/077044
- (22) International Filing Date: 28 August 2007 (28.08.2007)
- (25) Filing Language: English
- (26) Publication Language: English
- (30) Priority Data:  
60/840,759 28 August 2006 (28.08.2006) US  
60/840,901 28 August 2006 (28.08.2006) US
- (71) Applicant (for all designated States except US):  
**THERMO ELECTRON SCIENTIFIC INSTRUMENTS LLC** [US/US]; 5225 Verona Road, Madison, WI 53711 (US).
- (72) Inventor; and
- (75) Inventor/Applicant (for US only): **DECK, Francis, J.** [US/US]; 4805 Regent Street, Madison, WI 53705 (US).
- (74) Agent: **KATZ, Charles, B.**; Thermo Fisher Scientific Inc., 355 River Oaks Parkway, San Jose, CA 95134 (US).

- (81) Designated States (unless otherwise indicated, for every kind of national protection available): AE, AG, AL, AM, AT, AU, AZ, BA, BB, BG, BH, BR, BW, BY, BZ, CA, CH, CN, CO, CR, CU, CZ, DE, DK, DM, DO, DZ, EC, EE, EG, ES, FI, GB, GD, GE, GH, GM, GT, HN, HR, HU, ID, IL, IN, IS, JP, KE, KG, KM, KN, KP, KR, KZ, LA, LC, LK, LR, LS, LT, LU, LY, MA, MD, ME, MG, MK, MN, MW, MX, MY, MZ, NA, NG, NI, NO, NZ, OM, PG, PH, PL, PT, RO, RS, RU, SC, SD, SE, SG, SK, SL, SM, SV, SY, TJ, TM, TN, TR, TT, TZ, UA, UG, US, UZ, VC, VN, ZA, ZM, ZW.
- (84) Designated States (unless otherwise indicated, for every kind of regional protection available): ARIPO (BW, GH, GM, KE, LS, MW, MZ, NA, SD, SL, SZ, TZ, UG, ZM, ZW), Eurasian (AM, AZ, BY, KG, KZ, MD, RU, TJ, TM), European (AT, BE, BG, CH, CY, CZ, DE, DK, EE, ES, FI, FR, GB, GR, HU, IE, IS, IT, LT, LU, LV, MC, MT, NL, PL, PT, RO, SE, SI, SK, TR), OAPI (BF, BJ, CF, CG, CI, CM, GA, GN, GQ, GW, ML, MR, NE, SN, TD, TG).

[Continued on next page]

(54) Title: SPECTROSCOPE WITH SPATIAL RESOLUTION CONTROL

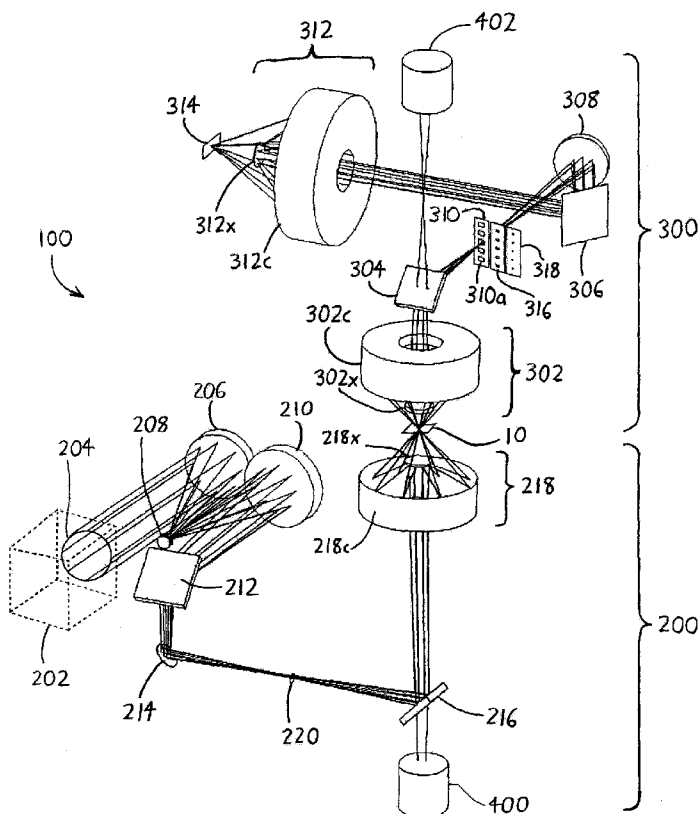

(57) Abstract: In a spectrometer, preferably in a spectrometric microscope, light from a specimen is collected at a collector objective element and delivered to a camera element, which in turn provides the light to a photosensitive detector. A focal plane is provided between the collector objective element and the camera element, and one or more aperture arrays may be situated in the focal plane to restrict the detector's field of view of the specimen to the areas within the apertures. By utilizing aperture arrays with apertures of different sizes and shapes, the spatial resolution of the spectrometer readings may be varied without the need to vary the optics of the spectrometer. As a result, if the optics are optimized to minimize vignetting, spatial resolution may be varied without adverse increases in vignetting.

WO 2008/027930 A2



**Published:**

- *without international search report and to be republished upon receipt of that report*

## SPECTROSCOPE WITH SPATIAL RESOLUTION CONTROL

### Cross-Reference to Related Applications

[0001] This application claims priority under 35 USC §119(e) to U.S. Provisional Patent Applications 60/840,759 and 60/840,901, both filed on 28 August 2006, the entireties of which are incorporated by reference herein.

### Field of the Invention

[0002] This document concerns an invention relating generally to spectrometers, and more particularly to spectrometers and spectroscopic imaging microscopes which compensate for optical vignetting effects in such a manner that measurement quality, and/or the ability to adjust spatial resolution of measurements, is enhanced.

### Background of the Invention

[0003] A molecular spectrometer (sometimes referred to as a spectroscope) is an instrument wherein a solid, liquid, or gaseous specimen is illuminated, often with non-visible light, such as light in the infrared region of the spectrum. The light from the specimen is then captured and analyzed to reveal information about the characteristics of the specimen. As an example, a specimen may be illuminated with infrared light having known intensity across a range of wavelengths, and the light transmitted and/or reflected by the specimen can then be captured for comparison to the illuminating light. Review of the captured spectra (i.e., light intensity vs. wavelength data) can then illustrate the wavelengths at which the illuminating light was absorbed by the specimen, which in turn can yield information about the chemical bonds present in the specimen, and thus its composition and other characteristics. To illustrate, libraries of spectra obtained from reference specimens of known composition are available, and by matching measured spectra versus these reference spectra, one can then determine the composition of the specimens from which the measured spectra were obtained.

[0004] Two common types of spectrometers are dispersive spectrometers and Fourier Transform (FT) spectrometers. In a dispersive spectrometer, a range of input light wavelengths are supplied to a specimen, and the output light from the specimen is received by a monochromator – a device which breaks the output light into its component wavelengths – with one or more detectors then measuring light intensity at these output wavelengths to generate the output spectrum. In an FT spectrometer, an interferometer is used to supply an interferogram – a time-varying mixture of several input light wavelengths – to a specimen,

and one or more detectors measure the (time-varying) output light from the specimen. The various wavelengths of the output light can then be “unscrambled” using mathematical techniques, such as the Fourier Transform, to obtain the intensity of the output light at its component wavelengths and thereby generate the output spectrum.

[0005] Spectroscopic microscopes then usefully incorporate the ability to make spectroscopic measurements into an optical microscope. A user may therefore use a spectroscopic microscope to view an image of a region of interest on a specimen (usually in magnified form), and also to obtain spectroscopic data from one or more locations on the region of interest. The spectroscopic measurements are often obtained by capturing spectroscopic data along a 1-dimensional row of areas on the region of interest (i.e., at areas spaced along a line on the region of interest), and then repeatedly capturing spectroscopic data from adjacent 1-dimensional rows. In other words, the linear array of spectroscopically-sampled areas is stepped sideways to ultimately capture spectroscopic data over a 2-dimensional array of areas over the region of interest. As a result, the user can view an image of the region of interest, and can also review the spectra (and thus the composition) of the specimen over the region of interest.

[0006] An important issue for users is the spatial resolution of a spectroscopic microscope, i.e., the size of the area over which each spectroscopic measurement is taken. Since each spectroscopic measurement from an area effectively provides the spectra of all substances present in the area (or at least the spectra of those substances which are responsive to the incident light), a spectroscopic measurement over a large area can be “coarse”: it can reflect the presence of numerous substances, though a user may not be able to visually assign each detected substance to a particular area seen through the microscope. In other words, while a user might see an area and spectroscopically determine the presence of certain substances, a user might not know where each substance specifically resides on the area – and such information can be highly useful. In contrast, a spectroscopic measurement taken over a smaller area can provide the desired information, since the location of the detected substance(s) is more specifically located. However, spectroscopic measurements captured over a smaller area tend to have a lower signal-to-noise ratio (i.e., they are noisier). This is largely because less light can practically be detected from a smaller area, and the lesser detected light leads to lower signal levels. A user can compensate for a lower signal-to-noise ratio by increasing the exposure time (i.e., the time over which the area is illuminated, and over which light is detected therefrom), and/or by taking multiple exposures from the area and combining them (e.g., averaging them), which tends to attenuate the effect of noise.

These procedures require greater measurement time, which is also undesirable from the user's standpoint.

[0007] Because of the foregoing tradeoff between spatial resolution and signal-to-noise ratio, it is useful for users to have variable resolution in a spectroscopic microscope – in effect, the ability to shift between coarse resolution wherein spectral measurements are taken over larger areas, and fine resolution wherein spectral measurements are taken over smaller areas. An example of such an arrangement is illustrated in published U.S. Patent Appln. 2002/0034000 to *Hoult et al.*, and in its associated U.S. Patent Appln. 2002/0033452 to *Hoult et al.* In these references, variable resolution is provided by inserting a set of magnifying optics within the light path between the specimen and the spectroscopic detector. The problem with this approach is that it introduces yet another drawback: “vignetting,” a condition wherein the light from the area(s) under analysis on the specimen is non-uniformly supplied to the spectroscopic detector. If one considers that the detector effectively receives a projected optical image of each area under analysis, vignetting usually involves the problem that the center of the projected image of the area is bright – the integrity of the image is preserved – but the brightness decreases toward the edges of the image. Vignetting therefore leads to the problem that the spectrometric measurements from the specimen area are skewed, with the nonuniform illumination across the received image providing higher signal levels nearer the center of the image/area, and diminished signal levels near the edges of the image/area. As a result, the spectra from the substance(s) at the center of the area/image are more strongly represented in the area's spectroscopic measurements than the substance(s) nearer the edges of the image/area. More generally, vignetting leads to less than optimal signal strength owing to the loss in light near the edges of the image/area. Vignetting tends to arise as a side-effect from the use of “off-angle” arrangements of optical elements, i.e., from reflection or refraction of light at angles to the optical axis of the lenses and/or mirrors used for the microscope optics (at least those lenses/mirrors used to perform spectroscopic measurement functions). The use of greater off-axis angles tend to lead to greater vignetting, and thus greater reductions in image luminance and signal strength, because light is lost as it “leaks” from the usable areas (the apertures) of successive optical elements. In a spectroscopic microscope, it is often possible to adapt the optics so that vignetting is minimized for one of the resolution/magnification settings, but this then tends to enhance vignetting in the other settings as additional optics are introduced to enable the settings. It would therefore be useful to have a means for reducing the effects of vignetting in

spectrometers and spectroscopic microscopes, and to allow the use of variable spatial resolution settings with reduced vignetting effects.

### Summary of the Invention

[0008] The invention involves spectroscopic devices and methods which are intended to at least partially solve the aforementioned problems, and which can be beneficially implemented in spectroscopic microscopes. To give the reader a basic understanding of some of the advantageous features of the invention, following is a brief summary of preferred versions of the devices and methods, with reference being made to the accompanying drawing to enhance the reader's understanding. Since this is merely a summary, it should be understood that more details regarding preferred versions of the invention may be found in the Detailed Description set forth elsewhere in this document. The claims set forth at the end of this document then define the various versions of the invention in which exclusive rights are secured.

[0009] The accompanying drawings present a schematic of an exemplary spectroscope which incorporates features of the invention, with the spectroscope being generally denoted with the reference numeral **100**. The spectroscope has a specimen stage **10** suitable for bearing a specimen to be analyzed, illumination components for illuminating the specimen (generally designated at **200**), and collection components for collecting spectroscopic measurements from the illuminated specimen (these components being generally designated by **300**). On the illumination side **200** of the device **100**, a light source **202** (shown in phantom), such as an interferometer emitting modulated infrared light, has a source output aperture **204** from which light is emitted, with the emitted light preferably being defined by a collimated output light beam. One or more intermediate source optical elements (i.e., reflectors, lenses, or the like) – here focusing reflectors **206**, **208**, and **210**, and planar folding reflectors **212**, **214**, and **216** – then pass the light from the light source **202** to a source objective optical element **218**. The source objective element **218** is preferably a Schwarzschild objective, and is thus illustrated with a convex reflector **218x** receiving light from the light source **202**, and a concave reflector **218c** receiving light from the convex reflector **218x** and forwarding the light to the specimen stage **10**. In this arrangement, the intermediate source optical elements (more particularly elements **206**, **208**, and **210**) preferably magnify the source output aperture **204** of the light source **202** to at least substantially match the limiting aperture of the source objective element **218** (with the limiting aperture here being the working reflective area of the convex reflector **218x**). Since

the source output aperture **204** for the illumination side **200** is imaged to the limiting aperture of the source objective element **218**, light is not lost about the perimeter of the convex reflector **218x** of the source objective element **218** (or from the perimeters of any of the intermediate source optical elements **206**, **208**, and **210**, **212**, **214**, and **216**), and light is transmitted between the light source **202** and the specimen stage **10** with high efficiency (low loss). While the magnification of the source output aperture **204** reduces the size of the light beam as it travels to the source objective element **218**, the overall illumination area at the specimen stage **10** is still effectively increased.

[0010] On the collection side **300** of the spectroscopy **100**, a collector objective optical element **302** then receives the light from the specimen stage **10**. The collector objective element **302** is also preferably a Schwarzschild objective, with a concave reflector **302c** receiving the light and directing it to a convex reflector **302x** (with this reflector **302x** defining the limiting aperture of the collector objective element **302**). The light from the collector objective element **302** is then supplied to intermediate collector optical elements, namely planar folding reflectors **304** and **306** and focusing reflector **308**, as well as through an aperture array **310** (which will be discussed at greater length below). A camera optical element **312** then receives the light, and is again preferably a Schwarzschild objective with a convex reflector **312x** receiving the light (and defining a camera limiting aperture) and directing it to a concave reflector **312c**. The light is then delivered to an image plane along which a detector **314** is aligned, with the detector **314** preferably being a multi-element detector (i.e., a detector array). In a manner similar to the arrangement at the illumination side **200**, the intermediate collector optical elements **304**, **306**, and **308** (and in particular the focusing reflector **308**) preferably adapt the light from the collector objective element **302** such that it has a diameter at least substantially matching the camera limiting aperture (the working area of convex reflector **312x**) when received thereon. Thus, light loss is reduced on the collection side **300** as well, with the efficient transmission of light from the light source **202** to the source objective element **218** in the illumination side **200** being continued in the collection side **300** from the collector objective element **302** to the camera element **312**. As a result, light throughput to the specimen **10** is high, and light transmission from the specimen **10** to the detector **314** is also high, reducing the effects of light loss from vignetting and allowing the collection of higher-strength signals at the detector **314**.

[0011] In addition, the optical elements of the illumination side **200** are preferably selected such that the source output aperture **204** is at least substantially critically imaged to the source objective element **218** (and thus to the specimen at the specimen stage **10**) – in

other words, the light rays from each point on the light source **202** are directed to corresponding points on the convex reflector **218x**, thereby preserving the image of the light source **202** on the convex reflector **218x**. Similarly, the optical elements of the collection side **300** are preferably selected so that the specimen **10** is at least substantially critically imaged to the detector **314** (i.e., so that the collector objective limiting aperture **302x** is at least substantially critically imaged to the camera limiting aperture **312x**). Such critical imaging will directly image a selected region of the light source **202** to a corresponding region on the specimen **10** (e.g., a glowing filament within the light source **202**), and will also directly image the specimen to the detector **314**. This is useful, for example, where a user is interested in studying a particular region of interest on the specimen **10**: the user may align this portion with the filament of the light source **202**, which represents a particularly bright area of the output beam of the light source **202**, to generate higher-intensity light output from the region of interest (and thus higher spectral signal strength). However, diffuse illumination could be used instead, if desired.

[0012] Another useful feature of the invention relates to the use of the aperture array **310** to allow variation in spatial resolution. The collector objective element **302** and the intermediate optical element **308** (i.e., the focusing reflector **308**) have focal lengths, preferably equal focal lengths, which define a focal plane situated between these elements **302** and **308**. The aperture array **310** is situated along this focal plane, and it bears multiple apertures **310a**, each of which is preferably identically sized and configured. Each of these apertures **310a** receive a portion of the light from the collector objective element **302**, i.e., a portion of the image of the specimen **10** (preferably the critical image), and pass it to the camera element **312** and the multi-element detector **314**. The detector **314** is aligned such that its elements each receive an image of a portion of the specimen stage **10** from a respective aperture **310a** in the aperture array **310**, and the detector elements thereby generate spectra which are dependent on the characteristics of the specimen as “seen” within the fields of view defined by the aperture array **310**. By providing supplemental aperture arrays **316**, **318**, etc. which each bear apertures which are differently sized from the apertures in the other aperture arrays, and by placing the desired aperture array **310** within the focal plane between the collector objective element **302** and the intermediate optical element **308**, a user may vary the sizes of the regions on the specimen **10** from which spectra are captured, and may thereby vary the spatial resolution of the spectroscopy system **100**. In a preferred arrangement, all aperture arrays **310**, **316**, **318**, etc. are mounted to be interchangeably positionable along the focal plane, as by providing the aperture arrays **310**, **316**, **318**, etc. in a translatable row (as

depicted in the drawing) so that a user may index through them to the desired resolution setting. Since spectral resolution may be changed without changing the optical magnification of the spectroscope **100** (and thus without any change in vignetting), so long as the spectroscope **100** is designed with minimal vignetting, it will have minimal vignetting at all spatial resolution settings.

[0013] As noted above, the foregoing spectroscope arrangement is usefully provided in a spectroscopic microscope. An exemplary microscope arrangement is also illustrated in the drawing, with a light source **400** (e.g., a light source emitting in the visible spectrum) providing light to the specimen stage **10** and the specimen via the source objective element **218**, and with a viewing optical element **402** receiving the resulting light from the specimen via the collector objective element **302**. The viewing optical element **402** may take the form of an eyepiece through which a user can view the specimen, and/or it could take the form of the input lens of a video camera or other imaging system. In the exemplary microscope system shown in the drawing, it should be understood that the folding reflectors **216** and **304** are dichroic, and are coated or otherwise treated to reflect the light utilized by the spectroscope (e.g., infrared light) and to pass the light utilized by the microscope optics **402**, and thus the folding reflectors **216** and **304** are effectively invisible to the microscope light source **400** and viewing element **402**.

[0014] Further advantages, features, and objects of the invention will be apparent from the remainder of this document in conjunction with the associated drawings.

### **Brief Description of the Drawings**

[0015] **FIG. 1** is a perspective view of an exemplary spectroscopic microscope with illumination elements **200** (including light source **202**) illuminating a specimen **10** and collection elements **300** (including detector **314**) collecting the resulting signals/images.

### **Detailed Description of Preferred Versions of the Invention**

[0016] To briefly review the foregoing discussion and the exemplary spectroscopic microscope of **FIG. 1**, input light from the light source **202** is provided to the specimen **10** via the source objective element **218**, wherein the aperture of the light source **202** is matched to the aperture of the source objective element **218** via one or more of the intermediate optical elements **206**, **208**, **210**, **212**, **214**, and **216** to maximize light throughput at the illumination side **200**. The light from the specimen **10** is collected at the collector objective element **302**, and is delivered to the camera element **312** (and to the detector **314**) via one or more of the

intermediate optical elements **304**, **306**, and **308**, which similarly match the apertures of the camera element **312** and the collector objective element **302** to maximize light throughput on the collection side **300**. As a result, light loss from vignetting effects is reduced and the intensity and uniformity of illumination are improved, thereby enhancing the sensitivity and accuracy of spectral measurements. It is also notable that by minimizing the number of limiting apertures in the device, alignment of the device's optics during routine maintenance and repair becomes significantly easier.

[0017] Additionally, an aperture array **310** (and supplemental aperture arrays **316**, **318**, etc. having differently-sized apertures) may be situated at a focus provided between the collector objective element **302** and the camera element **312**. Each aperture **310a** is imaged to an element of the detector **314**, and limits the field of view of the detector **314** at a corresponding region of the specimen **10**, thereby defining the spatial resolution of the spectrometer **100**. Alternatively, if the aperture arrays **310** / **316** / **318** are removed, the full area of each element / pixel of the detector **314** will define the field of view (and hence the spatial resolution) at the specimen **10**. If this field of view is larger than the spatial resolution that is achieved when the aperture array **310** is present, then the spectroscopy **100** will have two distinct spatial resolution settings with the use of a single aperture array **310**. Since spatial resolution is varied without any need to insert new optical elements or otherwise affect magnification, changes in spatial resolution have no impact on vignetting, and thus a spectroscopy **100** designed with minimal vignetting will maintain this benefit as spatial resolution is varied. Additionally, since no new optical elements are required to vary spatial resolution, the spectroscopy **100** also avoids the cost and bulk of such elements.

[0018] Looking to the illumination side **200** of the spectroscopy **100**, an additional focus **220** is usefully included between the light source **202** and the source objective element **218** (more specifically, between the folding reflectors **214** and **216** in **FIG. 1**). This allows the use of a source objective element **218** having a finite conjugate (finite focus), and thus allows a more compact layout between the elements of the illumination side **200** of the device **100**. Additionally, if desired, a limiting aperture could be inserted here to limit the area of illumination onto the specimen **10**.

[0019] The various optical elements of the spectroscopy **100** can be selected and arranged by one of ordinary skill in the field of optical design by use of design tools such as ZEMAX optical design software (ZEMAX Development Corporation, Bellevue, WA, USA). Following is a set of exemplary elements that may be used in the spectroscopy **100** shown in **FIG. 1**:

[0020] Focusing reflector **206**: Concave spherical mirror with 150 mm focal length, 10 degree off-axis angle, and distance of 155 mm to next surface.

[0021] Focusing reflector **208**: Concave spherical mirror with 20 mm focal length, 12 degree off axis angle, and distance of 150 mm to next surface.

[0022] Focusing reflector **210**: Concave spherical mirror with 100 mm focal length, 6 degree off axis angle, and distance of 281 mm to focal plane **220** (the location of which is chosen to match the back focal length of the source objective element **218**).

[0023] Folding reflectors **212**, **214**, and **216**: Plane mirrors.

[0024] Source objective element **218**: Uses a Schwarzschild objective from a Thermo Electron Centaurus FT-IR microscope (Thermo Fisher Scientific Inc., Madison, WI, USA) and adjusting the spacing between its reflectors **218x** and **218c** for optimal performance at a magnification ratio of 15.

[0025] The foregoing optical elements **206**, **208**, **210**, **212**, **214**, **216**, and **218** are used with an interferometer **202** having a light source output aperture (exit pupil) **204** of 38 mm, and which is spaced 250 mm from the focusing reflector **206**. The optical elements should be selected with clear apertures sized large enough to capture all of the incident light, preferably even if slightly misaligned. The off-axis spherical reflectors **206**, **208**, and **210** introduce some astigmatism and aberration, and to some degree conflict with the goal of imaging all apertures on the illumination and collection sides **200** and **300** to the limiting apertures therein. However, aberrations are minimal where the included angles between entrance and exit beams on the reflectors **206**, **208**, and **210** are chosen to be less than about 30 degrees.

[0026] Looking then to the collection side **300** of the spectroscope **100**, the following exemplary elements may be used:

[0027] Collector objective element **302**: Can be chosen to be identical with the source objective element **218**.

[0028] Folding reflectors **304** and **306**: Plane mirrors.

[0029] Focusing reflector **308**: Toroidal mirror with roughly 188 mm focal length when operated with an off axis angle of 8 degrees. The reflector **308** is located one focal length from the focal plane at **310** – which is itself located one focal length from the convex reflector **302x** of the collector objective optical element **302** – and two focal lengths from the reflector **312x** of the camera optical element **312**. Thus, the reflector **308** is equidistant from reflectors **302x** and **312x** (at two focal lengths away), and is adjusted in position to image reflectors **302x** and **312x** onto one another with unit magnification while collimating the beam after the focal plane at **310**.

[0030] Camera optical element **312**: Uses a Schwarzschild objective with a focal length chosen to provide overall magnification of 1.2 (which is not an essential feature of the design, and is chosen merely to provide a given spatial resolution at the specimen for a selected array detector **314**). Critical imaging of mirrors 308 to 309 is preferred in order to minimizing vignetting in the collection optics.

[0031] As for the choice of the microscope viewing element **402** and light source **400**, their design is trivial, and will depend on the desired configuration for the microscope, e.g., whether the light source **400** is to provide illumination over only the visible range of the spectrum or over other wavelengths instead or as well (e.g., over UV wavelengths); whether the viewing element **402** is to provide direct viewing (monocular or binocular) and/or viewing via electronic image capture (e.g., video capture); and so forth.

[0032] The specimen stage **10** may take the form of any suitable specimen stage. Preferably, the specimen stage **10** is motorized to allow translation in two dimensions about the focal plane, and also preferably rotation about the beam axes of the source objective element **218** and/or the collector objective optical element **302**.

[0033] The aperture arrays **310**, **316**, **318**, etc. can be formed in any suitable manner with any suitable aperture sizes and shapes. The apertures **310a** are dimensioned in accordance with the magnification of the collector objective element **302** and the spatial resolution desired, e.g., if the collector objective element **302** has a magnification of 10x and a spatial resolution of 6 microns is desired, the apertures **310a** should be 60 microns in diameter. Apertures of this size can be generated, for example, by etching or laser drilling of a metal film. The aperture arrays **310**, **316**, **318** can each be manually installed when desired, or in a more preferred arrangement, they are provided on a motorized stage which allows a user to index to a desired resolution setting. The stage may bear the aperture arrays **310**, **316**, **318**, etc. in a form similar to that shown in **FIG. 1**, whereby the stage may be translated until the desired array is in place, or the aperture arrays might be situated in radially-oriented rows on a rotatable stage so that a user may rotate the stage to achieve the desired resolution setting.

[0034] The detector **314** may be any suitable detector, such as an array of mercury-cadmium-telluride (MCT) photoconductive elements similar to that used in the Thermo Electron Continuum XL FT-IR microscope (Thermo Fisher Scientific Inc., Madison, WI, USA).

[0035] It is emphasized that a wide variety of other components, layout distances, and general placements are possible, and thus the invention may assume a wide variety of forms

other than the exemplary one shown in **FIG. 1**. This includes the possibility of omitting or combining optical elements (e.g., omitting one or more of the folding reflectors **212**, **214**, **216**, **304** and **306**, which are merely included to provide a convenient layout, and/or using two of the focusing reflectors **206**, **208**, and **210** rather than three), or adding optical elements (such as additional folding mirrors). Additionally, different types of optical elements may generally be used in place of those noted above: lenses might be used in place of reflectors, different types of lenses / reflectors may be used (e.g., toroidal elements might be used in place of spherical ones), and so forth. In this respect, it is noted that the term “Schwarzschild objective” is used throughout this document to refer to dual concave-convex reflector sets, and thus encompasses species of optical elements which are arguably not Schwarzschild elements, if such elements are strictly defined (e.g., Cassegrain elements).

[0036] Further, while the spectroscope **100** is shown as using a transmissive mode of operation (with spectra being generated from light transmitted through the specimen **10**), a reflective mode could be implemented as well (or instead), as by providing a light source at the location of the microscope viewing element **402**, or by inserting a dichroic mirror somewhere along the beam path at the collection side **300** and providing light source input to this mirror.

[0037] It is notable that the vignetting reduction features of the invention can be implemented without use of the variable spatial resolution features. For example, the aperture array **310** (as well as the camera optical element **312** and the intermediate elements **306** and **308**) might be eliminated, and the collector objective element **302** could simply be used as the camera element for imaging the specimen **10** onto the detector **314** (the detector **314** here being moved to a position near where the aperture array **310** is shown in **FIG. 1**). Similarly, the variable spatial resolution features of the invention could be implemented without the vignetting reduction features. However, these two aspects of the invention are particularly beneficial when combined, particularly since variable spatial resolution can be attained while preserving the imaging of the limiting apertures of the optics across the collection side **300** of the spectroscope **100** (and more generally, across both the illumination and collection sides **200** and **300**). In other words, the invention allows compatibility between variable spatial resolution and anti-vignetting, whereas these features have generally been incompatible in the past.

[0038] It should be understood that the version of the invention described above is merely exemplary, and the invention is not intended to be limited to this versions. Rather, the scope of rights to the invention is limited only by the claims set out below, and the invention

encompasses all different versions that fall literally or equivalently within the scope of these claims.

## Claims

What is claimed is:

1. A spectroscope including:
  - a. a specimen stage;
  - b. a collector objective element receiving light from the specimen stage;
  - c. an aperture array having multiple apertures therein, with the apertures each receiving a portion of the light from the collector objective element;
  - d. a camera element receiving the light from the aperture array; and
  - e. a multi-element detector receiving the light from the camera element, with the elements of the detector each receiving an image of a portion of the specimen stage from a respective aperture in the aperture array.
  
2. The spectroscope of claim 1 wherein:
  - a. wherein the aperture array bears several apertures, each aperture being identically sized and configured;
  - b. further including a supplemental array bearing several apertures which are differently sized from the apertures in the aperture array, wherein the aperture array and supplemental array are mounted to be interchangeably positionable along the same plane.
  
3. The spectroscope of claim 1 wherein the specimen stage is critically imaged onto the aperture array.
  
4. The spectroscope of claim 1 wherein.
  - a. the collector objective element has a collector objective limiting aperture;
  - b. the camera element has a camera limiting aperture; and
  - c. at the camera element, the light received from the aperture array has a diameter at least substantially matching the camera limiting aperture.

5. The spectroscope of claim 1 further including an intermediate optical element:
  - a. receiving the light from the collector objective element and the aperture array, and
  - b. supplying the light to the camera element.
6. The spectroscope of claim 5 wherein the camera element receives collimated light from the intermediate optical element.
7. The spectroscope of claim 5 wherein the aperture array is located at both:
  - a. the focus of the collector objective element, and
  - b. the focus of the intermediate optical element.
8. The spectroscope of claim 7 further including one or more supplemental arrays, wherein:
  - a. the aperture array and supplemental arrays are mounted to be interchangeably positioned at the foci of the collector objective element and the intermediate optical element; and
  - b. each array bears apertures which are differently sized from the apertures in the other arrays.
9. The spectroscope of claim 5 wherein the focal length of the intermediate optical element is equal to the focal length of the collector objective element.
10. The spectroscope of claim 5 wherein the path traveled by the light between the intermediate optical element and the camera element has a length equal to the path traveled by the light between the collector objective element and the intermediate optical element.
11. The spectroscope of claim 10 wherein the aperture array is located at the focus of both the collector objective element and the intermediate optical element.
12. The spectroscope of claim 11 wherein the focal length of the intermediate optical element is equal to the focal length of the collector objective element.

13. The spectroscope of claim 1 further including a viewing optical element receiving light from the collector objective element, wherein the light received by the viewing optical element is at least substantially within the visible spectrum.
14. The spectroscope of claim 13 wherein the light received by the camera element is at least substantially within the infrared spectrum.
15. A spectroscope including:
  - a. a specimen stage;
  - b. a collector objective element receiving light from the specimen stage;
  - c. an intermediate optical element receiving the light from the collector objective element;
  - d. a focal plane between the collector objective element and the intermediate optical element, wherein the focal plane is located at the focus of both the collector objective element and the intermediate optical element;
  - e. a camera element receiving the light from the intermediate optical element; and
  - f. a multi-element detector situated at the image plane and receiving light from the camera element, with each element of the detector receiving an image of a portion of the specimen stage.
16. The spectroscope of claim 15 further including an aperture array at the focal plane, the aperture array having several apertures therein.
17. The spectroscope of claim 16 further including a supplemental array:
  - a. interchangeably positionable with the aperture array along the focal plane, and
  - b. bearing several apertures which are differently sized from the apertures in the aperture array.
18. The spectroscope of claim 15 wherein the intermediate optical element collimates the light received from the collector objective element.
19. The spectroscope of claim 15 wherein the focal length of the intermediate optical element is equal to the focal length of the collector objective element.

20. The spectroscope of claim 15 wherein the path traveled by the light between the intermediate optical element and the camera element has a length equal to the path traveled by the light between the collector objective element and the intermediate optical element.
21. The spectroscope of claim 20 wherein the focal length of the intermediate optical element is equal to the focal length of the collector objective element.
22. The spectroscope of claim 15:
  - a. wherein the light received by the camera element is at least substantially within the infrared spectrum; and
  - b. further including a viewing optical element receiving light from the specimen stage, wherein the light received by the viewing optical element is at least substantially within the visible spectrum.
23. The spectroscope of claim 22 wherein the viewing optical element receives light from the specimen stage via the collector objective element.

24. A spectroscopic method for use in a spectroscope wherein the spectroscope includes:
- i. a specimen stage;
  - ii. a collector objective element receiving light from the specimen stage;
  - iii. a camera element receiving light from the collector objective element; and
  - iv. a multi-element detector receiving the light from the camera element,
- the method including the steps of:
- a. situating a first aperture array to receive light from the collector objective element and provide light to the camera element, wherein the first aperture array has multiple apertures therein, with each aperture receiving an image of a portion of the specimen stage from the collector objective element;
  - b. obtaining readings from the detector elements, wherein each detector element's reading is dependent on an image of a portion of the specimen stage received from one of the apertures in the first aperture array;
  - c. situating a second aperture array to receive light from the collector objective element and provide light to the camera element, wherein the second aperture array has multiple apertures therein which are differently sized than the apertures of the first aperture array, with each aperture receiving an image of a portion of the specimen stage from the collector objective element;
  - d. obtaining readings from the detector elements, wherein each detector element's reading is dependent on an image of a portion of the specimen stage received from one of the apertures in the second aperture array.
25. The spectroscopic method of claim 24 further including the steps of:
- a. directing at least a portion of the light from the collector objective element to a viewing optical element, and
  - b. visually viewing the light through the viewing optical element.

FIG. 1

