

(12) STANDARD PATENT
(19) AUSTRALIAN PATENT OFFICE

(11) Application No. **AU 2009228496 B2**

(54) Title
System and method for precoding matrix index feedback interaction with discontinuous reception

(51) International Patent Classification(s)
H04W 52/02 (2009.01)

(21) Application No: **2009228496** (22) Date of Filing: **2009.03.20**

(87) WIPO No: **WO09/120605**

(30) Priority Data

(31) Number	(32) Date	(33) Country
12/058,448	2008.03.28	US

(43) Publication Date: **2009.10.01**

(44) Accepted Journal Date: **2013.05.16**

(71) Applicant(s)
Research In Motion Limited

(72) Inventor(s)
Womack, James Earl;Cai, Zhijun;Yu, Yi

(74) Agent / Attorney
Spruson & Ferguson, L 35 St Martins Tower 31 Market St, Sydney, NSW, 2000

(56) Related Art
FENG et al., "A Joint Unitary Precoding and Scheduling Algorithm for MIMO-OFDM System with Limited Feedback", IEEE International Symposium on Microwave, Antenna, Propagation, and EMC Technologies For Wireless Communications, 2007
3GPP TS 36.321, "Evolved Universal Terrestrial Radio Access (E-UTRA) Medium Access Control (MAC) protocol specification (Release 8)", V8.1.0, March 2008

(12) INTERNATIONAL APPLICATION PUBLISHED UNDER THE PATENT COOPERATION TREATY (PCT)

(19) World Intellectual Property Organization
International Bureau



(43) International Publication Date
1 October 2009 (01.10.2009)

(10) International Publication Number
WO 2009/120605 A1

- (51) International Patent Classification:
H04W 52/02 (2009.01)
- (21) International Application Number:
PCT/US2009/037854
- (22) International Filing Date:
20 March 2009 (20.03.2009)
- (25) Filing Language: English
- (26) Publication Language: English
- (30) Priority Data:
12/058,448 28 March 2008 (28.03.2008) US
- (71) Applicant (for all designated States except US): **RESEARCH IN MOTION LIMITED** [CA/CA]; 295 Phillip Street, Waterloo, Ontario, N2L 3W8 (CA).
- (72) Inventors; and
- (75) Inventors/Applicants (for US only): **CAI, Zhijun** [CN/US]; 3009 Manor Green Blvd., Euless, TX 76039 (US). **WOMACK, James, Earl** [US/US]; 32 Linderhof Circle, Bedford, TX 76022 (US). **YU, Yi** [CN/US]; 1124 Hidden Ridge Dr., Apt. 2126, Irving, TX 75038 (US).
- (74) Agents: **CONLEY ROSE, P.C.** et al.; 5601 Granite Parkway, Suite 750, Plano, TX 75024 (US).
- (81) Designated States (unless otherwise indicated, for every kind of national protection available): AE, AG, AL, AM, AO, AT, AU, AZ, BA, BB, BG, BH, BR, BW, BY, BZ,

CA, CH, CN, CO, CR, CU, CZ, DE, DK, DM, DO, DZ, EC, EE, EG, ES, FI, GB, GD, GE, GH, GM, GT, HN, HR, HU, ID, IL, IN, IS, JP, KE, KG, KM, KN, KP, KR, KZ, LA, LC, LK, LR, LS, LT, LU, LY, MA, MD, ME, MG, MK, MN, MW, MX, MY, MZ, NA, NG, NI, NO, NZ, OM, PG, PH, PL, PT, RO, RS, RU, SC, SD, SE, SG, SK, SL, SM, ST, SV, SY, TJ, TM, TN, TR, TT, TZ, UA, UG, US, UZ, VC, VN, ZA, ZM, ZW.

(84) Designated States (unless otherwise indicated, for every kind of regional protection available): ARIPO (BW, GH, GM, KE, LS, MW, MZ, NA, SD, SL, SZ, TZ, UG, ZM, ZW), Eurasian (AM, AZ, BY, KG, KZ, MD, RU, TJ, TM), European (AT, BE, BG, CH, CY, CZ, DE, DK, EE, ES, FI, FR, GB, GR, HR, HU, IE, IS, IT, LT, LU, LV, MC, MK, MT, NL, NO, PL, PT, RO, SE, SI, SK, TR), OAPI (BF, BJ, CF, CG, CI, CM, GA, GN, GQ, GW, ML, MR, NE, SN, TD, TG).

Declarations under Rule 4.17:

- as to applicant's entitlement to apply for and be granted a patent (Rule 4.17(ii))
- as to the applicant's entitlement to claim the priority of the earlier application (Rule 4.17(iii))

Published:

- with international search report (Art. 21(3))

[Continued on next page]

(54) Title: SYSTEM AND METHOD FOR PRECODING MATRIX INDEX FEEDBACK INTERACTION WITH DISCONTINUOUS RECEPTION

WO 2009/120605 A1

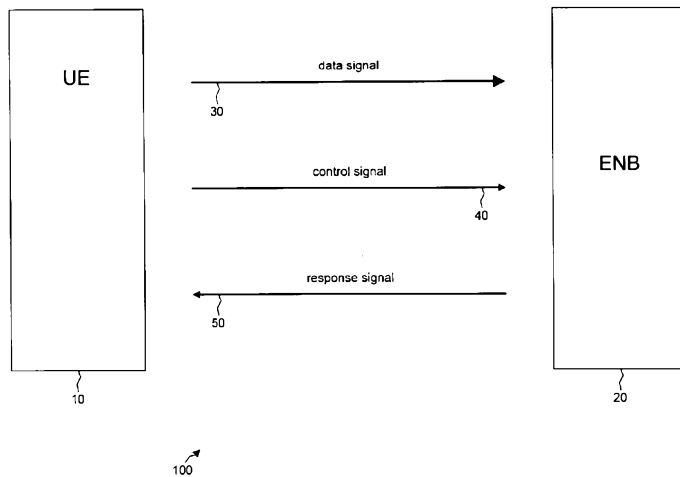

FIG. 1

(57) Abstract: A user equipment (UE) is provided that includes a processor configured to transmit a precoding matrix index (PMI) using one of an assigned periodic PMI reporting resource that precisely aligns with the start of an on-duration of a discontinuous reception (DRX) operation mode of the UE and a first assigned periodic PMI reporting resource after the start of an on-duration of a discontinuous reception (DRX) operation mode of the UE.



— *before the expiration of the time limit for amending the claims and to be republished in the event of receipt of*

amendments (Rule 48.2(h))

System and Method for Precoding Matrix Index Feedback Interaction with Discontinuous Reception

BACKGROUND

[0001] Easily transportable devices with wireless telecommunications capabilities, such as mobile telephones, personal digital assistants, handheld computers, and similar devices, will be referred to herein as user equipment (UE). The term "user equipment" may refer to a device and its associated Universal Integrated Circuit Card (UICC) that includes a Subscriber Identity Module (SIM) application, a Universal Subscriber Identity Module (USIM) application, or a Removable User Identity Module (R-UIM) application or may refer to the device itself without such a card. A UE might communicate with a second UE, some other element in a telecommunications network, an automated computing device such as a server computer, or some other device. A communications connection between a UE and another component might promote a voice call, a file transfer, or some other type of data exchange, any of which can be referred to as a call or a session.

[0002] As telecommunications technology has evolved, more advanced network access equipment has been introduced that can provide services that were not possible previously. This advanced network access equipment might include, for example, an evolved node B (ENB) rather than a base station or other systems and devices that are more highly evolved than the equivalent equipment in a traditional wireless telecommunications system. Such advanced or next generation equipment may be referred to herein as long-term evolution (LTE) equipment. Later generation or future advanced equipment that designates access nodes, for example nodes that provide radio access network (RAN) connectivity to UEs, are also referred to herein by the term ENB.

[0003] Some UEs have the capability to communicate in a packet switched mode, wherein a data stream representing a portion of a call or session is divided into packets that are given unique identifiers. The packets might then be transmitted from a source to a destination along different paths and might arrive at the destination at different times. Upon reaching the destination, the packets are reassembled into their original sequence based on the identifiers. Voice over Internet Protocol (VoIP) is a well-known system for packet switched-based voice communication over the Internet. The term "VoIP" will refer

herein to any packet switched voice call connected via the Internet, regardless of the specific technology that might be used to make the call.

[0004] For a wireless VoIP call, the signal that carries data between a UE and an ENB can have a specific set of frequency, code, and time parameters and other characteristics that might be specified by the ENB. A connection between a UE and an ENB that has a specific set of such characteristics can be referred to as a resource. An ENB typically establishes a different resource for each UE with which it is communicating at any particular time.

[0005] New wireless communications systems may employ multiple input multiple output (MIMO) communication techniques. MIMO involves one or both of the UE and the ENB concurrently using multiple antennas for transmitting and/or receiving. Depending upon the radio channel conditions, the multiple antennas may be employed to increase the throughput of the radio link between the UE and the ENB, for example by transmitting independent streams of data on each antenna, or to increase the reliability of the radio link between the UE and the ENB, for example by transmitting redundant streams of data on the multiple antennas. These different communications objectives may be obtained through spatial multiplexing in the first case and through spatial diversity in the second case. Receiving multiple concurrent transmissions from a multi-antenna transmitter by a multi-antenna receiver may involve complicated processing techniques and/or algorithms.

SUMMARY

An aspect of the present invention provides a user equipment (UE), comprising: a processor configured to control a receiver in the user equipment to have an active time; and the processor further configured to control a transmitter to stop transmitting precoding matrix index (PMI) transmissions when not in active time.

Another aspect of the present invention provides a method for transmitting a control signal from a user equipment (UE) to an evolved node B (eNB), comprising: determining when an active time of a discontinuous reception (DRX) operation mode of the UE is scheduled; and stopping a transmission of precoding matrix index (PMI) transmissions when not in active time.

Another aspect of the present invention provides a user equipment (UE), comprising: a processor configured to control a receiver in the user equipment to have an active time; and the processor further configured to control a transmitter to refrain from transmitting a precoding matrix index (PMI) when not in active time.

BRIEF DESCRIPTION OF THE DRAWINGS

[0006] For a more complete understanding of this disclosure, reference is now made to the following brief description, taken in connection with the accompanying drawings and detailed description, wherein like reference numerals represent like parts.

5 [0007] FIG. 1 is a block diagram of a telecommunications system according to an embodiment of the disclosure.

[0008] FIG. 2 is a diagram illustrating on-durations and off-durations for a user equipment according to an embodiment of the disclosure.

10 [0009] FIG. 3a is an illustration of a periodic precoding matrix index (PMI) reporting resource relative to an on-duration and a retransmission window associated with the on-duration according to an embodiment of the disclosure.

2009228496 16 Apr 2013

[0010] FIG. 3b is an illustration of a periodic precoding matrix index reporting resource relative to an on-duration and a retransmission window associated with the on-duration, depicting some precoding matrix index transmissions turned off according to an embodiment of the disclosure.

[0011] FIG. 3c is an illustration of a periodic precoding matrix index reporting resource relative to an on-duration and a retransmission window associated with the on-duration, depicting some precoding matrix index transmissions turned off according to an embodiment of the disclosure.

[0012] FIG. 3d is an illustration of a periodic precoding matrix index reporting resource relative to an on-duration and a retransmission window associated with the on-duration, depicting some precoding matrix index transmissions turned off according to an embodiment of the disclosure.

[0013] FIG. 3e is an illustration of a periodic precoding matrix index reporting resource relative to an on-duration and a retransmission window associated with the on-duration, depicting some precoding matrix index transmissions turned off according to an embodiment of the disclosure.

[0014] FIG. 3f is an illustration of a periodic precoding matrix index reporting resource relative to an on-duration and a retransmission window associated with the on-duration, depicting some precoding matrix index transmissions turned off according to an embodiment of the disclosure.

[0015] FIG. 4a is an illustration of a periodic precoding matrix index reporting resource relative to uplink sub-frames and downlink sub-frames of an evolved node B according to an embodiment of the disclosure.

[0016] FIG. 4b is an illustration of a periodic precoding matrix index reporting resource relative to an on-duration and a retransmission window associated with the on-duration, depicting some precoding matrix index transmissions turned off according to an embodiment of the disclosure.

[0017] FIG. 5a is an illustration of a method of transmitting precoding matrix index control signals according to an embodiment of the disclosure.

[0018] FIG. 5b is an illustration of another method of transmitting precoding matrix index control signals according to an embodiment of the disclosure.

[0019] FIG. 6 is a diagram of a wireless communications system including a user equipment operable for some of the various embodiments of the disclosure.

[0020] FIG. 7 is a block diagram of a user equipment operable for some of the various embodiments of the disclosure.

[0021] FIG. 8 is a diagram of a software environment that may be implemented on a user equipment operable for some of the various embodiments of the disclosure.

[0022] FIG. 9 illustrates an exemplary general-purpose computer system suitable for implementing the several embodiments of the present disclosure.

DETAILED DESCRIPTION

[0023] It should be understood at the outset that although illustrative implementations of one or more embodiments of the present disclosure are provided below, the disclosed systems and/or methods may be implemented using any number of techniques, whether currently known or in existence. The disclosure should in no way be limited to the illustrative implementations, drawings, and techniques illustrated below, including the exemplary designs and implementations illustrated and described herein, but may be modified within the scope of the appended claims along with their full scope of equivalents.

[0024] In one embodiment, a user equipment (UE), is provided comprising a processor configured to transmit a control a receiver in the user equipment to have an active time; and the processor further configured to control a transmitter to stop transmitting precoding matrix index (PMI) transmissions when not in active time.

[0025] In another embodiment, a method is provided for transmitting a control signal from a user equipment (UE) to an evolved node B (eNB). The method includes the steps of determining when an active time of a discontinuous reception (DRX) operation mode of the UE is scheduled; and stopping a transmission of precoding matrix index (PMI) transmissions when not in active time.

[0026] In another embodiment, a user equipment (UE) is provided that includes a processor configured to transmit a precoding matrix index (PMI) using one of an assigned periodic PMI reporting resource that precisely aligns with the start of an on-duration of a

discontinuous reception (DRX) operation mode of the UE and a first assigned periodic PMI reporting resource after the start of an on-duration of a discontinuous reception (DRX) operation mode of the UE.

[0027] In another embodiment, a user equipment (UE) is provided that includes a processor configured to transmit a precoding matrix index (PMI) using a first assigned periodic PMI reporting resource after the start of a retransmission window.

[0028] Figure 1 illustrates an embodiment of a wireless telecommunications system 100 that includes a UE 10 capable of communicating with an ENB 20 or a similar component. Transmissions of various types of information can take place between the UE 10 and the ENB 20. For example, the UE 10 might send the ENB 20 various types of application layer data such as VoIP data packets and data packets containing information related to web browsing, emailing, and other user applications, all of which may be referred to as user plane data. Other types of information related to the UE's application layer will be familiar to one of skill in the art. Any signal containing such information will be referred to herein as a data signal 30. Information associated with a data signal 30 will be referred to herein as user plane data.

[0029] The UE 10 might also send the ENB 20 various types of control signaling such as layer 1 scheduling requests, layer 1 control signaling (CQI, PMI, NACK/ACK, etc.), high layer radio resource control (RRC) messages and mobility measurement messages, and other control messages, all of which may be referred to as control plane data, and is familiar to one of skill in the art. The UE 10 typically generates such messages as needed to initiate or maintain a call. Any such signal will be referred to herein as a control signal 40. Information associated with a control signal 40 will be referred to herein as control plane data.

[0030] Precoding matrix index (PMI) control signals and/or messages are included among these control signals. A PMI control signal may be a message transmitted from the UE 10 to the ENB 20 that identifies an index into a codebook of matrices to be employed to precode MIMO radio transmissions. In some contexts, the PMI control signal may be referred to as PMI feedback. Precoding is an operation that the ENB 20 may perform when transmitting to the UE 10 that may overcome certain radio channel conditions in

order to improve the MIMO signal received by the UE 10. Transmitting an index from a codebook of matrices may be more efficient than transmitting the specific values of the precoding matrix. A matrix codebook comprises a set of matrices selected to closely approximate members of a much larger set of possible matrices with acceptable distortion. In some contexts, the PMI control signal may be referred to as the PMI. In some contexts precoding may also be referred to as adapting the communication parameters or adapting parameters.

[0031] In some cases, a dedicated channel might exist between the UE 10 and the ENB 20 via which control plane data may be sent. Requests to send data on the uplink may also use this dedicated channel. This may be called a scheduling request. In other cases, a random access channel (RACH) may be used to initiate a scheduling request. That is, in some cases, a request for resources to send control plane data may be sent via a RACH, and, in other cases, the control plane data itself might be sent via a RACH.

[0032] When the UE 10 sends a control signal 40 to the ENB 20, the ENB 20 might return a response signal or other control signal to the UE 10. For example, if the UE 10 sends a mobility measurement message to the ENB 20, the ENB 20 might respond by sending an acknowledgement message or some other handover-related control message to the UE 10. Other types of responses that the ENB 20 might send upon receiving a control signal 40 from the UE 10 will be familiar to one of skill in the art. Any such response by the ENB 20 to a control signal 40 sent by the UE 10 will be referred to herein as a response signal 50.

[0033] In order to save battery power, the UE 10 might periodically alternate between a high-power mode and a low-power mode. For example, using techniques known as discontinuous reception (DRX), the UE 10 might periodically enter short periods of relatively high power consumption during which data can be received. Such periods will be referred to herein as on-durations and/or active time. Between the on-durations, the UE 10 might enter longer periods in which power consumption is reduced and data is not received. Such periods will be referred to herein as off-durations. A balance between power savings and performance can be achieved by making the off-durations as long as

possible while still keeping the on-durations long enough for the UE 10 to properly receive data.

[0034] The term “DRX” is used generically to refer to discontinuous reception. To avoid confusion, the terms “on-duration” and “off-duration” may also be used herein to refer to a UE’s capability to receive data. Besides the on-duration, the active time defines the time that the UE is awake, which could be longer than the on-duration due to the possible inactivity timer running which will keep the UE awake for additional time. Additional related discussion is found in 3rd Generation Partnership Project (3GPP) Technical Specification (TS) 36.321.

[0035] Figure 2 illustrates an idealized view of on-durations and off-durations for the UE 10. On-durations 210 with higher power usage alternate in time with off-durations 220 with lower power usage. Traditionally, the UE 10 receives data only during the on-durations 210 and does not receive data during the off-durations 220. As an example, it might be determined that an entire cycle of one on-duration 210 and one off-duration 220 should last 20 milliseconds. Of this cycle, it might be determined that an on-duration 210 of 5 milliseconds is sufficient for the UE 10 to receive data without significant loss of information. The off-duration 220 would then last 15 milliseconds.

[0036] The determination of the sizes of the on-durations 210 and the off-durations 220 might be based on the quality of service (QoS) parameters of an application. For example, a VoIP call might need a higher level of quality (e.g., less delay) than an email transmission. When a call is being set up, the UE 10 and the ENB 20 enter a service negotiation stage in which a QoS is negotiated based on the maximum allowable delay, the maximum allowable packet loss, and similar considerations. The level of service to which the user of the UE 10 subscribes might also be a factor in the QoS negotiations. When the QoS parameters for a call have been established, the ENB 20 sets the appropriate sizes for the on-durations 210 and the off-durations 220 based on that QoS level.

[0037] Turning now to FIG. 3a, PMI control signal transmissions are discussed. A plurality of assigned periodic PMI reporting intervals 250 are shown relative to the on-duration 210 and a retransmission window 230. In some contexts, the assigned periodic PMI reporting intervals 250 may be referred to as assigned periodic PMI reporting

resources. The PMI reporting intervals 250 depicted include a first PMI reporting interval 250a, a second PMI reporting interval 250b, a third PMI reporting interval 250c, a fourth PMI reporting interval 250d, a fifth PMI reporting interval 250e, a sixth PMI reporting interval 250f, a seventh PMI reporting interval 250g, an eighth PMI reporting interval 250h, a ninth PMI reporting interval 250i, a tenth PMI reporting interval 250j, an eleventh PMI reporting interval 250k, and a twelfth PMI reporting interval 250l. It is understood that the assigned periodic PMI reporting intervals 250 in a network is an ongoing sequence, and that many PMI reporting intervals 250 precede the first PMI reporting interval 250a and many PMI reporting intervals 250 follow the twelfth PMI reporting interval 250l. In an embodiment, the UE 10 may transmit PMI control signals during each PMI reporting interval 250 using the assigned PMI reporting resources, as indicated in FIG. 3a by the solid line arrows. The retransmission window 230 provides an opportunity for the ENB 20 to retransmit data to the UE 10 that the UE 10 was unable to receive properly during the on-duration 210. Note that the UE 10 may transmit some of the PMI control signals during the on duration 210 and the retransmission window 230. This may require that the UE 10 have two or more antennas with two different RF chains – a first RF chain associated with a first antenna for receiving and a second RF chain associated with a second antenna for transmitting – so the UE 10 can receive and transmit concurrently.

[0038] Turning now to FIG. 3b, PMI control signal transmissions are discussed further. In an embodiment, it may be inefficient for the UE 10 to transmit PMI control signals on every PMI reporting interval 250. Specifically, during some of the PMI reporting intervals when the ENB 20 is not transmitting to the UE 10, there may be no benefit associated with the UE 10 sending PMI control signals to the ENB 20, because the ENB 20 need not adapt communication parameters for communicating with the UE 10 at that time. A wide variety of techniques may be employed to reduce the transmissions of PMI control signals. As depicted in FIG. 3b by dashed arrowed line segments, the UE 10 may turn off or stop transmitting PMI control signals during the first PMI reporting interval 250a, the second PMI reporting interval 250b and during the fifth PMI reporting interval 250e through the twelfth PMI reporting interval 250l, thereby saving the power that otherwise would have been consumed by transmitting the PMI control signals during the PMI reporting intervals 250a,

250b, 250e, 250f, 250g, 250h, 250i, 250j, 250k, and 250l. The UE 10 analyzes the schedule of the on-duration 210 and determines to transmit on one of the PMI reporting intervals 250 during the first PMI reporting interval after the start of the on-duration 210 and to continue to transmit the PMI control signal during each successive PMI reporting interval until the end of the on-duration 210 or the end of the active time. The UE 10 may be instructed by the ENB 20 that it should suspend transmitting PMI until the end of the on-duration 210 or the end of the active time. It is understood that each of the PMI control signals transmitted by the UE 10 is independent of the other PMI control signals transmitted by the UE 10 and may contain new information based on current radio channel conditions.

[0039] Turning now to FIG. 3c, PMI control signal transmissions are discussed further. In an embodiment, the UE 10 may transmit the PMI control signal during the PMI reporting interval that immediately precedes the on-duration 210 and continues to transmit the PMI control signal during each successive PMI reporting interval 250 until the end of the on-duration or the end of the active time. By beginning transmitting the PMI control signal transmissions before the start of the on-duration 210, the ENB 20 may be able to receive the PMI control signal from the UE 10, to process the PMI information, and to determine how to adapt communication parameters by the start of the on-duration 210. In some contexts this may be referred to as resuming PMI control signal transmissions.

[0040] Turning now to FIG. 3d, PMI control signal transmissions are discussed further. In an embodiment, the UE 10 continues to periodically transmit the PMI control signals until the retransmission window 230 has ended, then the UE 10 stops transmitting PMI control signals. The UE 10 may begin transmitting the PMI control signal either during the first PMI reporting interval 250 of the on-duration 210, for example the third PMI reporting interval 250c as depicted in FIG. 3b, or during the PMI reporting interval 250 that immediately precedes the on-duration, for example the second PMI reporting interval 250b, as depicted in FIG. 3c. As an example, in FIG. 3d the UE 10 is depicted as periodically transmitting PMI control signals from the third PMI reporting interval 250c through the eighth PMI reporting interval 250h. This scenario may also be described as transmitting the PMI control signal during a first assigned periodic PMI reporting resource after the start

of the on-duration 210 and transmitting the PMI control signal during each successive assigned periodic PMI reporting resource until the end of the retransmission window 230.

[0041] Turning now to FIG. 3e, PMI control signal transmissions are discussed further. It may be inefficient for the UE 10 to transmit PMI control signals after the on-duration 210 has concluded or stopped and before the retransmission window 230 begins. The UE 10 analyzes the schedule of the on-duration 210 and may turn off or stop periodic transmissions of the PMI control signal after the on-duration 210 has ended or at the end of the active time. For example, as depicted in FIG. 3e, the UE 10 may turn on periodic transmission of PMI control signals during the third PMI reporting interval 250c through the fourth PMI reporting interval 250d, turn off periodic transmission of PMI control signals during the fifth PMI reporting interval 250e through the seventh PMI reporting interval 250g, turn on or resume periodic transmission of PMI control signals for the eighth PMI reporting interval 250h, and then turn off periodic transmission of PMI control signals at the ninth PMI reporting interval 250i. In an embodiment, the UE 10 may also transmit the PMI control signal during the seventh PMI reporting interval 250g.

[0042] Turning now to FIG. 3f, PMI control signal transmissions are discussed further. In an embodiment, it may be desirable to transmit the PMI control signals only during the retransmission window 230. The UE 10 may begin transmitting the PMI control signal with the first PMI reporting interval 250 in the retransmission window 230 or with the PMI reporting interval 250 that immediately precedes the retransmission window 230 and to transmit PMI control signals during each successive PMI reporting interval 250 until the end of the retransmission window 230.

[0043] One will readily appreciate that the several PMI control signal transmission scenarios admit of a variety of related combinations and extensions along the lines of the description above. All of these combinations and extensions are contemplated by the present disclosure. Additional technical details related to discontinuous reception (DRX) operation modes and assigned periodic precoding matrix indicator reporting resources may be found in TS 36.300 and TS 36.321 both of which are hereby incorporated herein by reference for all purposes.

[0044] Turning now to FIG. 4a, the timing relationship between the PMI reporting intervals 250 and a plurality of uplink sub-frames and downlink sub-frames of an ENB is discussed. In a practical wireless network a number of time lags are observed between the UE 10 transmitting the PMI control signal and the ENB 20 adapting the communication parameters based on the PMI control signals. A propagation delay is introduced by the time it takes for the radio frequency signal emitted by the UE 10 containing the PMI control signal to propagate through the radio channel to the ENB 20. The ENB 20 processing is segmented into uplink sub-frames 260 and downlink sub-frames 270, for example a first uplink sub-frame 260a, a second uplink sub-frame 260b, a third uplink sub-frame 260c, a first downlink sub-frame 270a, a second downlink sub-frame 270b, and a third downlink sub-frame 270c. The timing of the uplink sub-frame 260 edges and the downlink sub-frame 270 edges may not align due to the propagation delay and/or oscillator drift between the UE 10 and the ENB 20. As an example, the PMI control signal transmitted during the third PMI reporting interval 250c may be received by the ENB 20 in the first uplink sub-frame 260a, processed by the ENB 20 to adapt communication parameters in the second uplink sub-frame 260b, and the newly adapted communication parameters may be employed by the ENB 20 for communicating with the UE 10 during the third downlink sub-frame 270c. In an embodiment, the best case sub-frame delay is about two sub-frames. In another embodiment, the sub-frame delay may be about three sub-frames or about four sub-frames.

[0045] Turning now to FIG. 4b, PMI control signal transmissions are discussed further. In an embodiment, the UE 10 takes the time lags discussed above with reference to FIG. 4a into account in determining when to begin periodic transmission of the PMI control signal before the on-duration 210 and before the retransmission window 230. As an example, as depicted in FIG. 4b, beginning periodic transmission of the PMI control signal with the third PMI reporting interval 250c may not provide enough lead time for the ENB 20 to receive, process, and adapt communication parameters by the beginning of the on-duration 210. If the UE 10 began periodic transmission of the PMI control signal with the third PMI reporting interval, the first downlink sub-frame and also possibly the second downlink sub-frame may not benefit from adaptation based on a fresh PMI control signal

and less efficient communication operation between the UE 10 and the ENB 20 may result. For example, the ENB 20 may use the previously transmitted PMI control signal that indexes to a precoding matrix that does not suit the current radio channel and excessive distortion may result. The excessive distortion may cause the UE 10 to fail to receive one or more data packets, for example, and the ENB 20 may need to retransmit the data packets using HARQ, possibly decreasing the throughput of the radio channel and increasing the UE 10 power consumption for waking up to listen to the retransmissions.

[0046] As depicted, the UE 10 begins periodic transmission of PMI control signals with the second PMI reporting interval 250b, thereby providing enough time to permit the ENB 20 to receive the PMI control signal, process the PMI control signal, and adapt communication parameters by the start of the on-duration 210. Similarly, the UE 10 may determine when to start or resume periodic transmission of the PMI control signal before the retransmission window 230 taking into account the time needed by the ENB 20 to receive the PMI control signal, process the PMI control signal, and adapt communication parameters by the start of the retransmission window 230. The ENB 20 may instruct the UE 10 how to determine when to start or resume periodic transmission of the PMI control signal before the retransmission window 230.

[0047] Turning now to FIG. 5a, a method 300 of the UE 10 for controlling PMI control signal transmissions is discussed. At block 305, the UE 10 determines when the next on-duration 210 is scheduled. The ENB 20 may instruct the UE 10 to begin this process. At block 310, the UE 10 determines when the retransmission window 230 associated with the on-duration 210 is scheduled to end. In block 315, the UE 10 identifies or selects a PMI reporting interval 250 that precedes the start of the on-duration 210. In an embodiment, the UE 10 may select any PMI reporting interval 250 that precedes the start of the on-duration 210. In another embodiment, the UE 10 may select the PMI reporting interval 250 that immediately precedes the start of the on-duration 210. Another way of describing the behavior of this embodiment is that the UE 10 may select the last PMI reporting interval 250 that occurs before the start of the on-duration 210. In another embodiment, the UE 10 takes into account the time lags of radio frequency signal propagation, timing offsets associated with oscillator drifts, and processing by the ENB 20 to select the PMI reporting

interval 250 that precedes the on-duration 210. In an embodiment, the UE 10 may estimate the time lags to consume about a time duration of two sub-frames. In another embodiment, the UE 10 may estimate the time lags to consume about a time duration of three sub-frames or four sub-frames. In some circumstances, depending on timing alignments between the on-duration 210, the UE 10 may select the last PMI reporting interval 250 that occurs before the start of the on-duration 210 or the UE 10 may select the next to the last PMI reporting interval 250 that occurs before the start of the on-duration 210. In another embodiment, however, the UE 10 may select the first PMI reporting interval after the start of the on-duration 210. The UE 10 may select the first PMI reporting interval as the precise start of the on-duration 210, when the PMI reporting interval 250 precisely aligns with the start of the on-duration 210.

[0048] At block 320, the UE 10 transmits the PMI control signal on the selected PMI reporting interval 250. In an embodiment, the processing of block 320 may include a waiting process or a sleeping process wherein the process 300 only executes block 320 at the appropriate time, for example at the time of the selected PMI reporting interval 250. At block 325, if the retransmission window 230 associated with the on-duration 210 has not been completed, the process 300 returns to block 320. By looping through blocks 320 and 325, the UE 10 periodically transmits the PMI control signal to the ENB 20. In an embodiment, it is understood that the UE 10 re-determines the PMI values and/or information for each new transmission of the PMI control signal. It is also understood that the UE 10 transmits the PMI control signal at about the assigned time of the PMI reporting interval 250 over assigned PMI reporting resources.

[0049] At block 325, if the retransmission window 230 associated with the on-duration 210 has completed, the processing returns to block 305. This can be understood to include stopping periodic transmission of PMI control signals until the method 300 returns to block 320.

[0050] Turning now to FIG. 5b, a method 350 of the UE 10 for controlling PMI control signal transmissions is discussed. At block 355, the UE 10 determines when the next on-duration 210 is scheduled to begin and to end. At block 360, the UE 10 determines when the retransmission window 230 associated with the next on-duration 210 is scheduled to

begin and end. In block 365, the UE 10 identifies or selects the PMI reporting interval that precedes the next scheduled on-duration 210 to start periodic PMI control signal transmissions. As described with respect to block 315 above, the UE 10 may select the PMI reporting interval according to several different selection criteria, all of which are also contemplated by the method 350.

[0051] At block 370, the UE 10 transmits the PMI control signal on the selected PMI reporting interval 250. In an embodiment, the processing of block 370 may include a waiting process or a sleeping process wherein the process 350 only executes block 370 at the appropriate time, for example at the time of the selected PMI reporting interval 250. At block 375, if the on-duration 210 has not completed, the method 350 returns to block 370. By looping through blocks 370 and 375, the UE 10 periodically transmits the PMI control signal to the ENB 20. In an embodiment, it is understood that the UE 10 re-determines the PMI values and/or information for each new transmission of the PMI control signal. It is also understood that the UE 10 transmits the PMI control signal at about the assigned time of the PMI reporting interval 250 over assigned PMI reporting resources.

[0052] At block 375, if the on-duration 210 has completed, the processing proceeds to block 380. At block 380, the UE 10 identifies or selects the PMI reporting interval that precedes the retransmission window 230 to start or resume periodic PMI control signal transmissions. As described with respect to block 315 above, the UE 10 may select the PMI reporting interval according to several different selection criteria, all of which are also contemplated by method 350. In another embodiment, however, after on-duration 210 has completed the method 350 may complete and no PMI control signals may be transmitted during the retransmission window 230.

[0053] At block 385, the UE 10 transmits the PMI control signal on the selected PMI reporting interval 250. In an embodiment, the processing of block 385 may include a waiting process or a sleeping process wherein the process 350 only executes block 385 at the appropriate time, for example at the time of the selected PMI reporting interval 250. At block 390, if the retransmission window 230 has not completed, the method 350 returns to block 385. By looping through blocks 385 and 390, the UE 10 periodically transmits the PMI control signal to the ENB 20. In an embodiment, it is understood that the UE 10 re-

determines the PMI values and/or information for each new transmission of the PMI control signal. It is also understood that the UE 10 transmits the PMI control signal at about the assigned time of the PMI reporting interval 250 over assigned PMI reporting resources.

[0054] At block 390, if the retransmission window 230 has completed, the processing returns to block 355. This can be understood to include stopping periodic transmission of PMI control signals until the method 350 returns to block 370.

[0055] FIG. 6 illustrates a wireless communications system including an embodiment of the UE 10. The UE 10 is operable for implementing aspects of the disclosure, but the disclosure should not be limited to these implementations. Though illustrated as a mobile phone, the UE 10 may take various forms including a wireless handset, a pager, a personal digital assistant (PDA), a portable computer, a tablet computer, or a laptop computer. Many suitable devices combine some or all of these functions. In some embodiments of the disclosure, the UE 10 is not a general purpose computing device like a portable, laptop or tablet computer, but rather is a special-purpose communications device such as a mobile phone, a wireless handset, a pager, a PDA, or a telecommunications device installed in a vehicle. In another embodiment, the UE 10 may be a portable, laptop or other computing device. The UE 10 may support specialized activities such as gaming, inventory control, job control, and/or task management functions, and so on.

[0056] The UE 10 includes a display 402. In an embodiment, the UE 10 includes two antennas 403 – a first antenna 403A and a second antenna 403B – which may be used for MIMO operations. The two antennas 403 may also permit the UE 10 to transmit the PMI control signals during the on-duration 210 and/or during the retransmission window 230 on the first antenna 403A while concurrently receiving signals sent by the ENB 20 to the UE 10 on the second antenna 403B. The UE 10 also includes a touch-sensitive surface, a keyboard or other input keys generally referred as 404 for input by a user. The keyboard may be a full or reduced alphanumeric keyboard such as QWERTY, Dvorak, AZERTY, and sequential types, or a traditional numeric keypad with alphabet letters associated with a telephone keypad. The input keys may include a trackwheel, an exit or escape key, a trackball, and other navigational or functional keys, which may be inwardly depressed to

provide further input function. The UE 10 may present options for the user to select, controls for the user to actuate, and/or cursors or other indicators for the user to direct.

[0057] The UE 10 may further accept data entry from the user, including numbers to dial or various parameter values for configuring the operation of the UE 10. The UE 10 may further execute one or more software or firmware applications in response to user commands. These applications may configure the UE 10 to perform various customized functions in response to user interaction. Additionally, the UE 10 may be programmed and/or configured over-the-air, for example from a wireless base station, a wireless access point, or a peer UE 10.

[0058] Among the various applications executable by the UE 10 are a web browser, which enables the display 402 to show a web page. The web page may be obtained via wireless communications with a wireless network access node, a cell tower, a peer UE 10, or any other wireless communication network or system 400. The network 400 is coupled to a wired network 408, such as the Internet. Via the wireless link and the wired network, the UE 10 has access to information on various servers, such as a server 410. The server 410 may provide content that may be shown on the display 402. Alternately, the UE 10 may access the network 400 through a peer UE 10 acting as an intermediary, in a relay type or hop type of connection.

[0059] FIG. 7 shows a block diagram of the UE 10. While a variety of known components of UEs 10 are depicted, in an embodiment a subset of the listed components and/or additional components not listed may be included in the UE 10. The UE 10 includes a digital signal processor (DSP) 502 and a memory 504. As shown, the UE 10 may further include a front end unit 506, a radio frequency (RF) transceiver 508, an analog baseband processing unit 510, a microphone 512, an earpiece speaker 514, a headset port 516, an input/output interface 518, a removable memory card 520, a universal serial bus (USB) port 522, a short range wireless communication sub-system 524, an alert 526, a keypad 528, a liquid crystal display (LCD), which may include a touch sensitive surface 530, an LCD controller 532, a charge-coupled device (CCD) camera 534, a camera controller 536, and a global positioning system (GPS) sensor 538. In an embodiment, the UE 10 may include another kind of display that does not provide a touch sensitive screen. In an

embodiment, the DSP 502 may communicate directly with the memory 504 without passing through the input/output interface 518.

[0060] In one embodiment, the front end unit 506 interfaces with the two antennas 403 and may comprise one receive chain and one transmit chain. One antenna 403 is for transmitting and the other antenna 403 is for receiving. This allows the UE 10 to transmit the PMI signals at the same time it is receiving control and/or data information from the ENB 20.

[0061] The DSP 502 or some other form of controller or central processing unit operates to control the various components of the UE 10 in accordance with embedded software or firmware stored in memory 504 or stored in memory contained within the DSP 502 itself. In addition to the embedded software or firmware, the DSP 502 may execute other applications stored in the memory 504 or made available via information carrier media such as portable data storage media like the removable memory card 520 or via wired or wireless network communications. The application software may comprise a compiled set of machine-readable instructions that configure the DSP 502 to provide the desired functionality, or the application software may be high-level software instructions to be processed by an interpreter or compiler to indirectly configure the DSP 502.

[0062] The antenna and front end unit 506 may be provided to convert between wireless signals and electrical signals, enabling the UE 10 to send and receive information from a cellular network or some other available wireless communications network or from a peer UE 10. In an embodiment, the antenna and front end unit 506 may include multiple antennas to support beam forming and/or multiple input multiple output (MIMO) operations. As is known to those skilled in the art, MIMO operations may provide spatial diversity which can be used to overcome difficult channel conditions and/or increase channel throughput. The antenna and front end unit 506 may include antenna tuning and/or impedance matching components, RF power amplifiers, and/or low noise amplifiers.

[0063] The RF transceiver 508 provides frequency shifting, converting received RF signals to baseband and converting baseband transmit signals to RF. In some descriptions a radio transceiver or RF transceiver may be understood to include other signal processing functionality such as modulation/demodulation, coding/decoding,

interleaving/deinterleaving, spreading/despreading, inverse fast Fourier transforming (IFFT)/fast Fourier transforming (FFT), cyclic prefix appending/removal, and other signal processing functions. For the purposes of clarity, the description here separates the description of this signal processing from the RF and/or radio stage and conceptually allocates that signal processing to the analog baseband processing unit 510 and/or the DSP 502 or other central processing unit. In some embodiments, the RF Transceiver 508, portions of the Antenna and Front End 506, and the analog baseband processing unit 510 may be combined in one or more processing units and/or application specific integrated circuits (ASICs).

[0064] The analog baseband processing unit 510 may provide various analog processing of inputs and outputs, for example analog processing of inputs from the microphone 512 and the headset 516 and outputs to the earpiece 514 and the headset 516. To that end, the analog baseband processing unit 510 may have ports for connecting to the built-in microphone 512 and the earpiece speaker 514 that enable the UE 10 to be used as a cell phone. The analog baseband processing unit 510 may further include a port for connecting to a headset or other hands-free microphone and speaker configuration. The analog baseband processing unit 510 may provide digital-to-analog conversion in one signal direction and analog-to-digital conversion in the opposing signal direction. In some embodiments, at least some of the functionality of the analog baseband processing unit 510 may be provided by digital processing components, for example by the DSP 502 or by other central processing units.

[0065] The DSP 502 may perform modulation/demodulation, coding/decoding, interleaving/deinterleaving, spreading/despreading, inverse fast Fourier transforming (IFFT)/fast Fourier transforming (FFT), cyclic prefix appending/removal, and other signal processing functions associated with wireless communications. In an embodiment, for example in a code division multiple access (CDMA) technology application, for a transmitter function the DSP 502 may perform modulation, coding, interleaving, and spreading, and for a receiver function the DSP 502 may perform despreading, deinterleaving, decoding, and demodulation. In another embodiment, for example in an orthogonal frequency division multiplex access (OFDMA) technology application, for the

transmitter function the DSP 502 may perform modulation, coding, interleaving, inverse fast Fourier transforming, and cyclic prefix appending, and for a receiver function the DSP 502 may perform cyclic prefix removal, fast Fourier transforming, deinterleaving, decoding, and demodulation. In other wireless technology applications, yet other signal processing functions and combinations of signal processing functions may be performed by the DSP 502.

[0066] The DSP 502 may communicate with a wireless network via the analog baseband processing unit 510. In some embodiments, the communication may provide Internet connectivity, enabling a user to gain access to content on the Internet and to send and receive e-mail or text messages. The input/output interface 518 interconnects the DSP 502 and various memories and interfaces. The memory 504 and the removable memory card 520 may provide software and data to configure the operation of the DSP 502. Among the interfaces may be the USB interface 522 and the short range wireless communication sub-system 524. The USB interface 522 may be used to charge the UE 10 and may also enable the UE 10 to function as a peripheral device to exchange information with a personal computer or other computer system. The short range wireless communication sub-system 524 may include an infrared port, a Bluetooth interface, an IEEE 802.11 compliant wireless interface, or any other short range wireless communication sub-system, which may enable the UE 10 to communicate wirelessly with other nearby mobile devices and/or wireless base stations.

[0067] The input/output interface 518 may further connect the DSP 502 to the alert 526 that, when triggered, causes the UE 10 to provide a notice to the user, for example, by ringing, playing a melody, or vibrating. The alert 526 may serve as a mechanism for alerting the user to any of various events such as an incoming call, a new text message, and an appointment reminder by silently vibrating, or by playing a specific pre-assigned melody for a particular caller.

[0068] The keypad 528 couples to the DSP 502 via the interface 518 to provide one mechanism for the user to make selections, enter information, and otherwise provide input to the UE 10. The keyboard 528 may be a full or reduced alphanumeric keyboard such as QWERTY, Dvorak, AZERTY and sequential types, or a traditional numeric keypad with

alphabet letters associated with a telephone keypad. The input keys may include a trackwheel, an exit or escape key, a trackball, and other navigational or functional keys, which may be inwardly depressed to provide further input function. Another input mechanism may be the LCD 530, which may include touch screen capability and also display text and/or graphics to the user. The LCD controller 532 couples the DSP 502 to the LCD 530.

[0069] The CCD camera 534, if equipped, enables the UE 10 to take digital pictures. The DSP 502 communicates with the CCD camera 534 via the camera controller 536. In another embodiment, a camera operating according to a technology other than Charge Coupled Device cameras may be employed. The GPS sensor 538 is coupled to the DSP 502 to decode global positioning system signals, thereby enabling the UE 10 to determine its position. Various other peripherals may also be included to provide additional functions, e.g., radio and television reception.

[0070] FIG. 8 illustrates a software environment 602 that may be implemented by the DSP 502. The DSP 502 executes operating system drivers 604 that provide a platform from which the rest of the software operates. The operating system drivers 604 provide drivers for the wireless device hardware with standardized interfaces that are accessible to application software. The operating system drivers 604 include application management services ("AMS") 606 that transfer control between applications running on the UE 10. Also shown in Figure 8 are a web browser application 608, a media player application 610, and Java applets 612. The web browser application 608 configures the UE 10 to operate as a web browser, allowing a user to enter information into forms and select links to retrieve and view web pages. The media player application 610 configures the UE 10 to retrieve and play audio or audiovisual media. The Java applets 612 configure the UE 10 to provide games, utilities, and other functionality. A component 614 might provide functionality related to PMI feedback interaction as described herein. Although the component 614 is shown in FIG. 8 at an application software level, the component 614 may be implemented at a lower system level than is illustrated in FIG. 8.

[0071] Some aspects of the system 100 described above may be implemented on any general-purpose computer with sufficient processing power, memory resources, and

network throughput capability to handle the necessary workload placed upon it. FIG. 9 illustrates a typical, general-purpose computer system suitable for implementing aspects of one or more embodiments disclosed herein. The computer system 680 includes a processor 682 (which may be referred to as a central processor unit or CPU) that is in communication with memory devices including secondary storage 684, read only memory (ROM) 686, random access memory (RAM) 688, input/output (I/O) devices 690, and network connectivity devices 692. The processor 682 may be implemented as one or more CPU chips.

[0072] The secondary storage 684 is typically comprised of one or more disk drives or tape drives and is used for non-volatile storage of data and as an over-flow data storage device if RAM 688 is not large enough to hold all working data. Secondary storage 684 may be used to store programs which are loaded into RAM 688 when such programs are selected for execution. The ROM 686 is used to store instructions and perhaps data which are read during program execution. ROM 686 is a non-volatile memory device which typically has a small memory capacity relative to the larger memory capacity of secondary storage. The RAM 688 is used to store volatile data and perhaps to store instructions. Access to both ROM 686 and RAM 688 is typically faster than to secondary storage 684.

[0073] I/O devices 690 may include printers, video monitors, liquid crystal displays (LCDs), touch screen displays, keyboards, keypads, switches, dials, mice, track balls, voice recognizers, card readers, paper tape readers, or other well-known input devices.

[0074] The network connectivity devices 692 may take the form of modems, modem banks, ethernet cards, universal serial bus (USB) interface cards, serial interfaces, token ring cards, fiber distributed data interface (FDDI) cards, wireless local area network (WLAN) cards, radio transceiver cards such as code division multiple access (CDMA) and/or global system for mobile communications (GSM) radio transceiver cards, and other well-known network devices. These network connectivity devices 692 may enable the processor 682 to communicate with an Internet or one or more intranets. With such a network connection, it is contemplated that the processor 682 might receive information from the network, or might output information to the network in the course of performing the above-described method steps. Such information, which is often represented as a

sequence of instructions to be executed using processor 682, may be received from and outputted to the network, for example, in the form of a computer data signal embodied in a carrier wave. The network connectivity devices 692 may also include one or more transmitter and receivers for wirelessly or otherwise transmitting and receiving signal as are well known to one of ordinary skill in the art.

[0075] Such information, which may include data or instructions to be executed using processor 682 for example, may be received from and outputted to the network, for example, in the form of a computer data baseband signal or signal embodied in a carrier wave. The baseband signal or signal embodied in the carrier wave generated by the network connectivity devices 692 may propagate in or on the surface of electrical conductors, in coaxial cables, in waveguides, in optical media, for example optical fiber, or in the air or free space. The information contained in the baseband signal or signal embedded in the carrier wave may be ordered according to different sequences, as may be desirable for either processing or generating the information or transmitting or receiving the information. The baseband signal or signal embedded in the carrier wave, or other types of signals currently used or hereafter developed, referred to herein as the transmission medium, may be generated according to several methods well known to one skilled in the art.

[0076] The processor 682 executes instructions, codes, computer programs, scripts which it accesses from hard disk, floppy disk, optical disk (these various disk based systems may all be considered secondary storage 684), ROM 686, RAM 688, or the network connectivity devices 692. While only one processor 682 is shown, multiple processors may be present. Thus, while instructions may be discussed as executed by a processor, the instructions may be executed simultaneously, serially, or otherwise executed by one or multiple processors.

[0077] In another embodiment, a method is provided for transmitting a control signal from a user equipment (UE) to an evolved node B (ENB). The method includes determining when an on-duration of a discontinuous reception (DRX) operation mode of the UE is scheduled. The method includes beginning a periodic transmission of a precoding matrix index (PMI) control signal using one of an assigned periodic PMI

reporting resource that precisely aligns with the start of the on-duration and a first assigned periodic PMI interval after the scheduled start of the on-duration. The method may also include comprising stopping the periodic transmission of the PMI control signal after the end of one of the on-duration and an active time. The method may also include determining when a retransmission window ends, where the retransmission window is associated with the on-duration and beginning a periodic PMI control signal transmission at the time of a first assigned periodic PMI interval after the scheduled start of the retransmission window and stopping the periodic transmission of the PMI control signal after the retransmission window ends. The method may also include stopping the periodic transmission of the PMI control signal after a retransmission window ends, wherein the retransmission window is associated with the on-duration.

[0078] While several embodiments have been provided in the present disclosure, it should be understood that the disclosed systems and methods may be embodied in many other specific forms without departing from the spirit or scope of the present disclosure. The present examples are to be considered as illustrative and not restrictive, and the intention is not to be limited to the details given herein. For example, the various elements or components may be combined or integrated in another system or certain features may be omitted, or not implemented.

[0079] Also, techniques, systems, subsystems and methods described and illustrated in the various embodiments as discrete or separate may be combined or integrated with other systems, modules, techniques, or methods without departing from the scope of the present disclosure. Other items shown or discussed as coupled or directly coupled or communicating with each other may be indirectly coupled or communicating through some interface, device, or intermediate component, whether electrically, mechanically, or otherwise. Other examples of changes, substitutions, and alterations are ascertainable by one skilled in the art and could be made without departing from the spirit and scope disclosed herein.

CLAIMS:

1. A user equipment (UE), comprising:
a processor configured to control a receiver in the user equipment to have an active time; and
5 the processor further configured to control a transmitter to stop transmitting precoding matrix index (PMI) transmissions when not in active time.
2. The UE of claim 1 wherein the active time is part of a discontinuous receive (DRX) cycle.
10
3. The UE of any of the preceding claims wherein the user equipment is part of a long term evolution (LTE) network.
4. The UE of any of the preceding claims wherein the active time includes one of
15 an on-duration and a retransmission window.
5. A method for transmitting a control signal from a user equipment (UE) to an evolved node B (eNB), comprising:
determining when an active time of a discontinuous reception (DRX) operation
20 mode of the UE is scheduled; and
stopping a transmission of precoding matrix index (PMI) transmissions when not in active time.
6. The method of claim 5 wherein the UE and eNB are part of a long term evolution
25 (LTE) network.
7. The method of claim 5 or 6 wherein the active time includes one of an on-duration and a retransmission window.
- 30 8. A computer readable medium having computer-readable code embodied therein for execution by a processor in a computing device for causing the device to implement the steps of the method of any one of claims 5 to 7.
9. A user equipment (UE), comprising:
35 a processor configured to control a receiver in the user equipment to have an active time; and

the processor further configured to control a transmitter to refrain from transmitting a precoding matrix index (PMI) when not in active time.

5 10. A user equipment (UE) substantially as herein described with reference to an embodiment as shown in the accompanying drawings.

11. A method for transmitting a control signal from a user equipment (UE) to an evolved node B (eNB), said method substantially as herein described with reference to an embodiment as shown in the accompanying drawings.

10

Research In Motion Limited
Patent Attorneys for the Applicant/Nominated Person
SPRUSON & FERGUSON

15

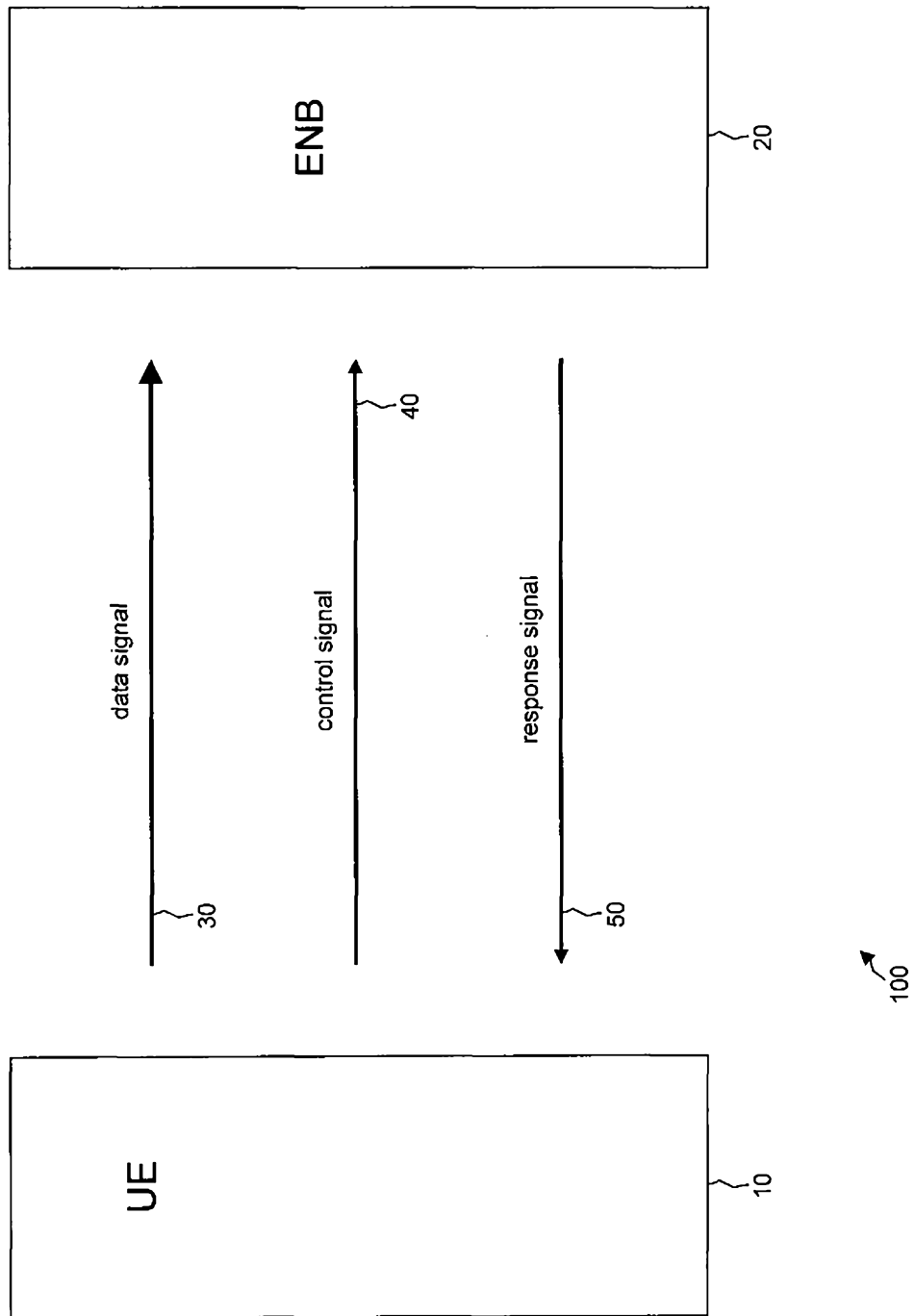

FIG. 1

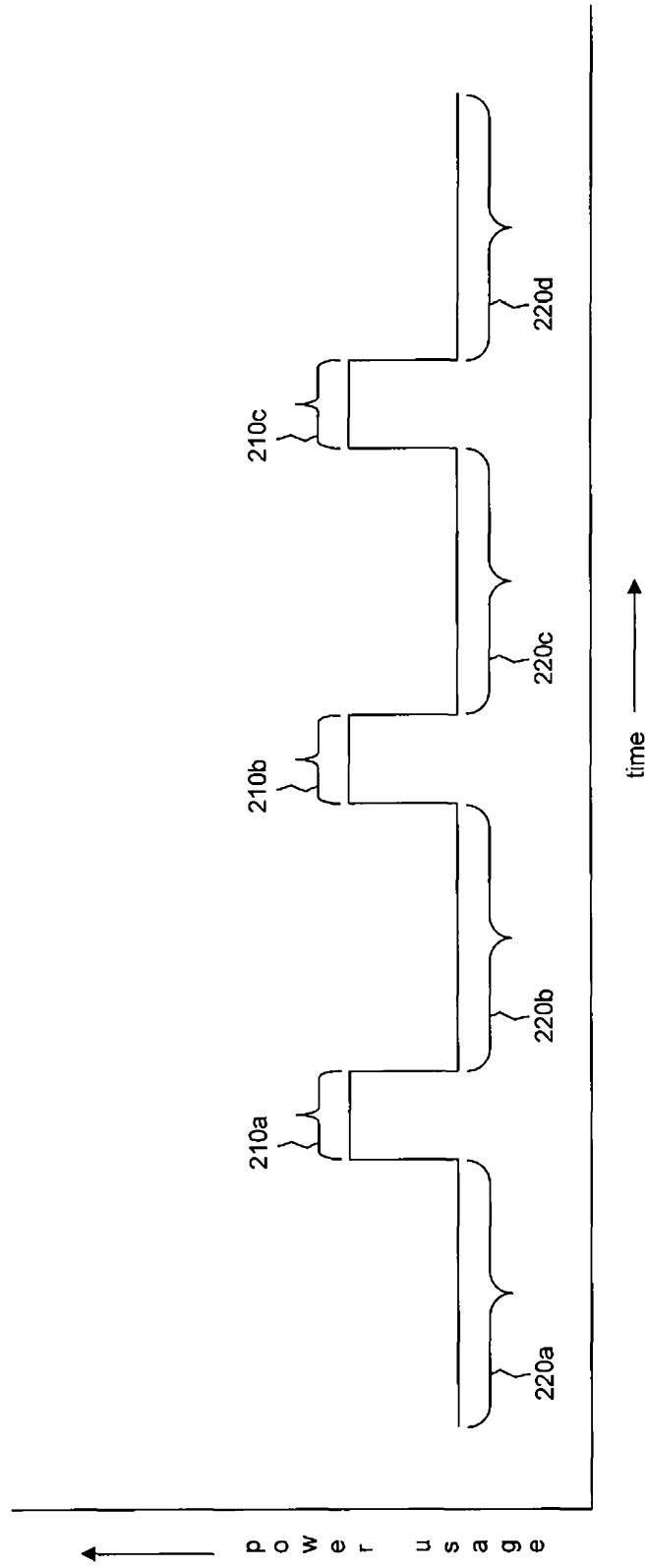
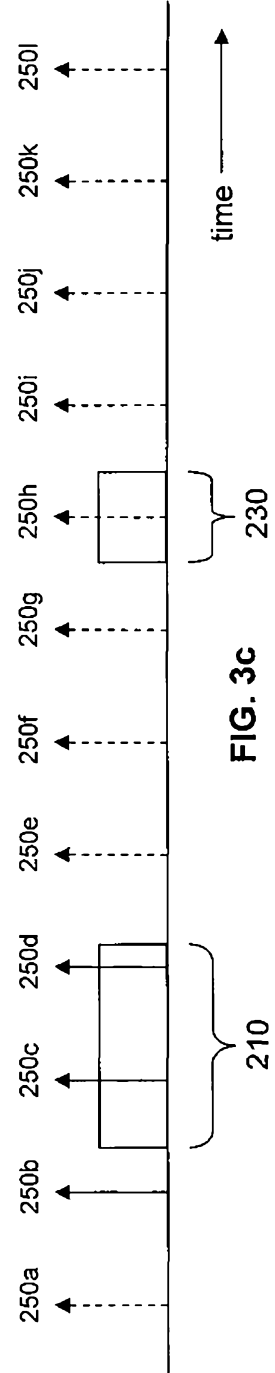
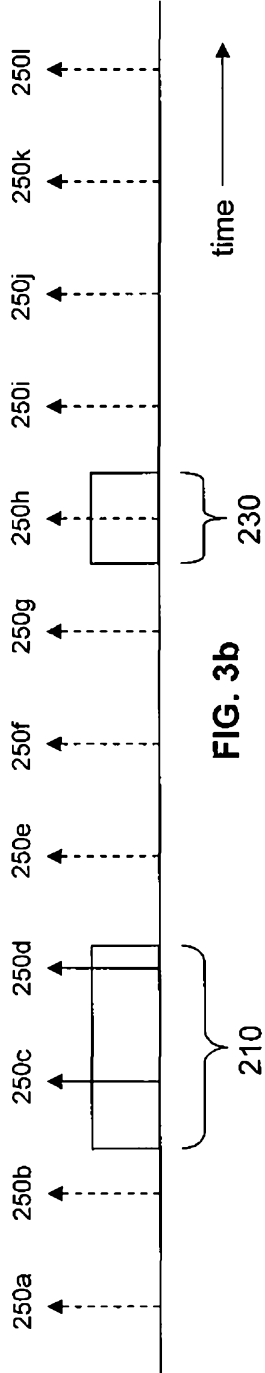
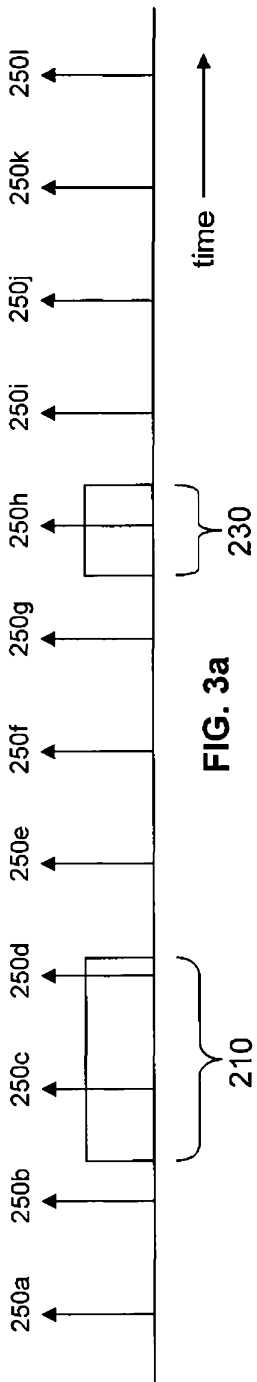
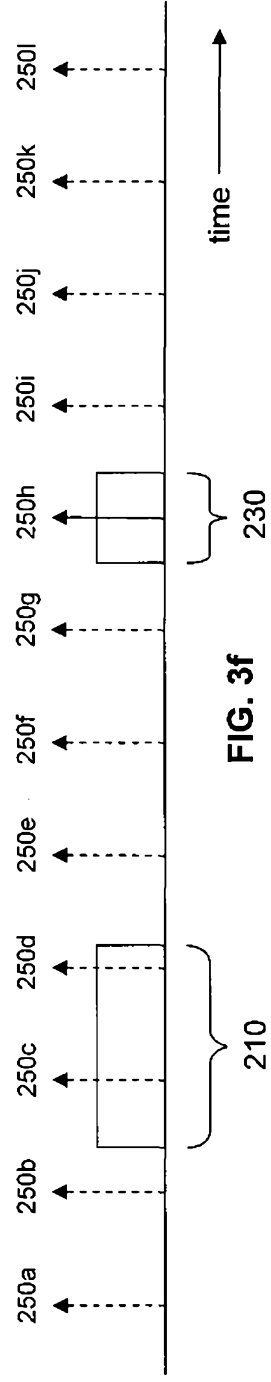
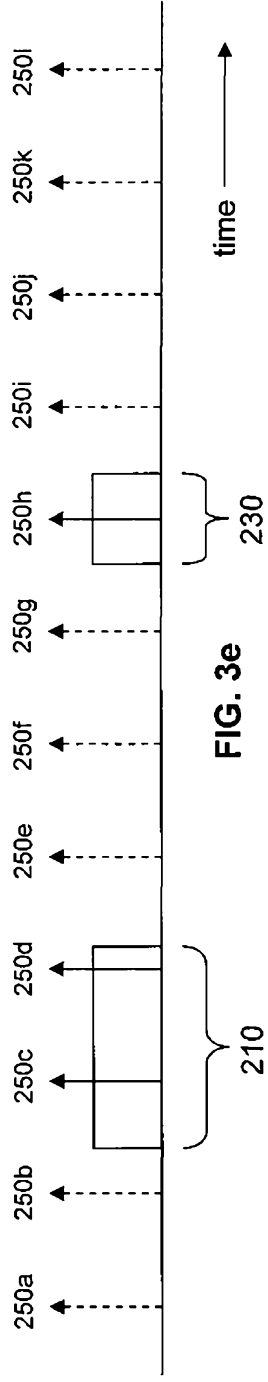
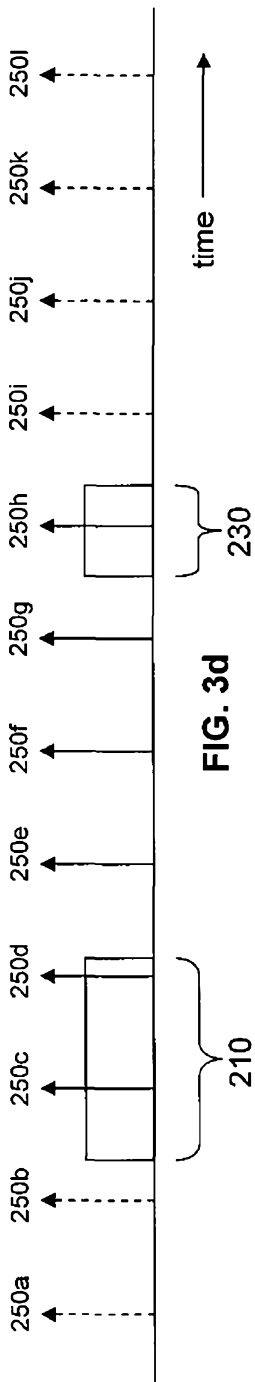

FIG. 2





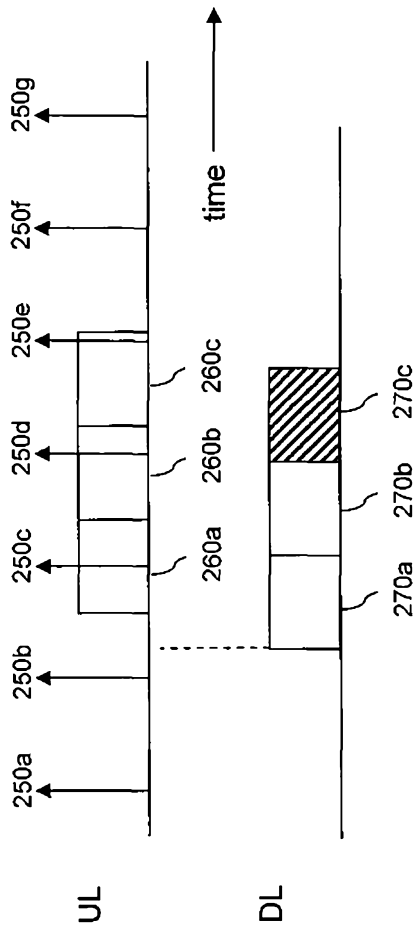

FIG. 4a

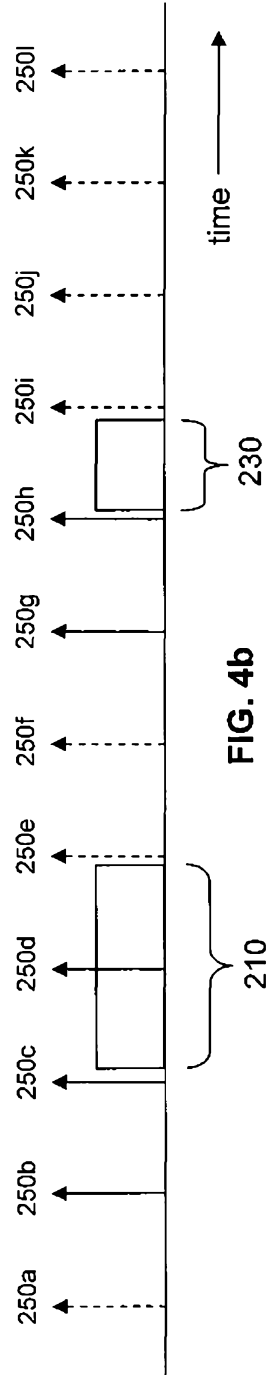

FIG. 4b

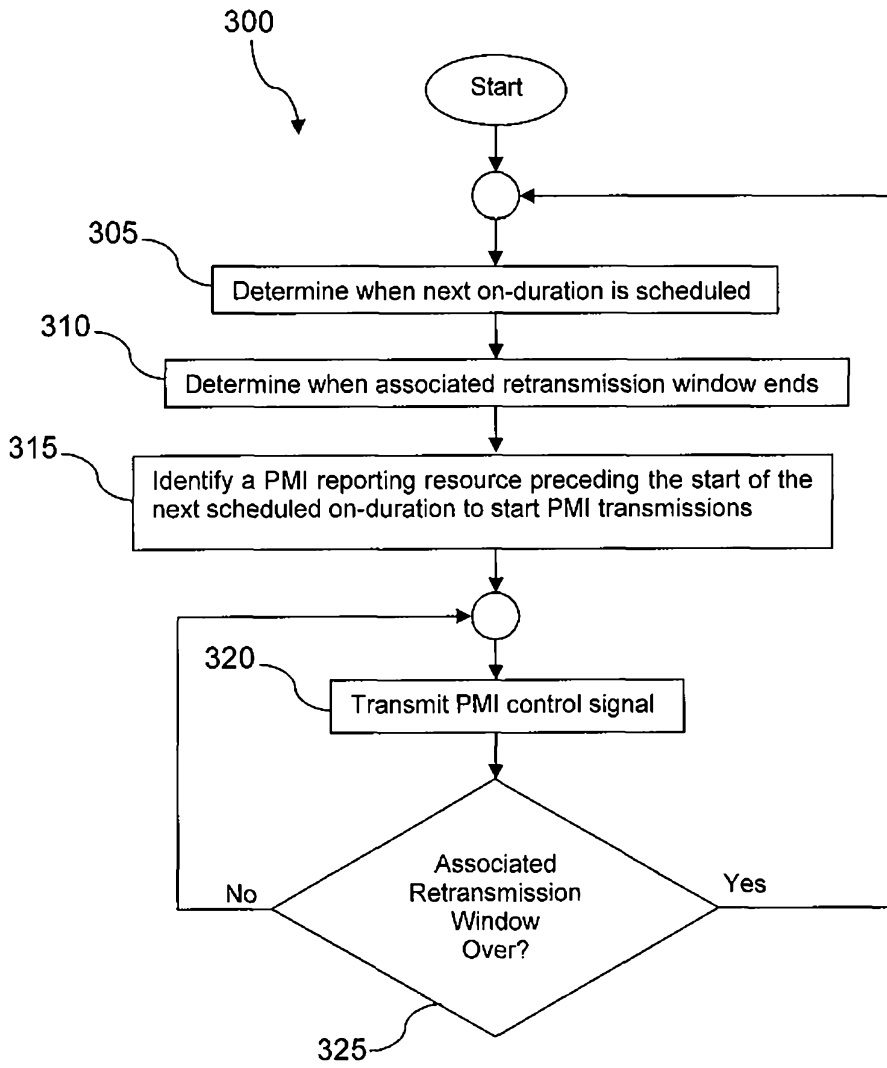

FIG. 5a

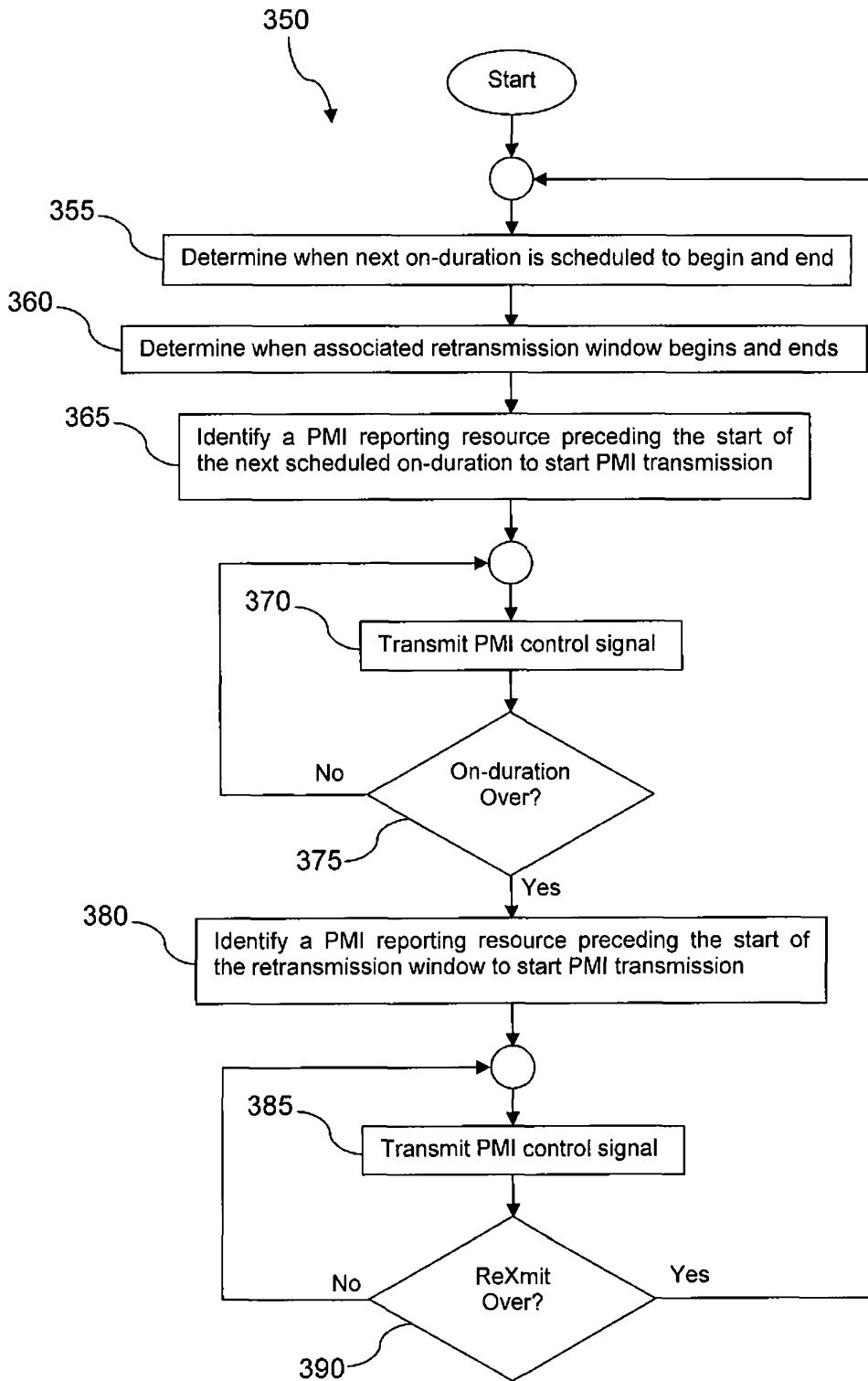
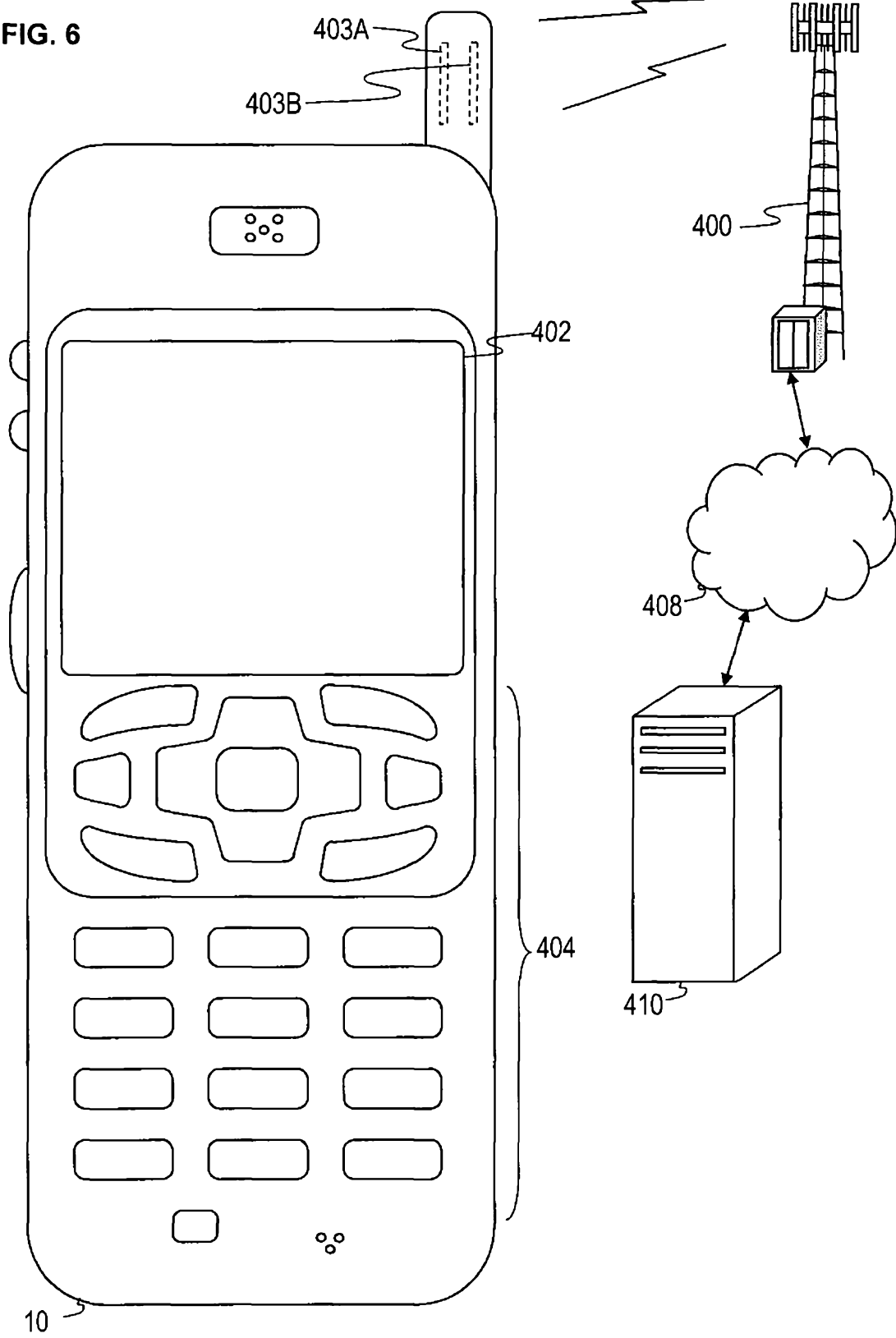
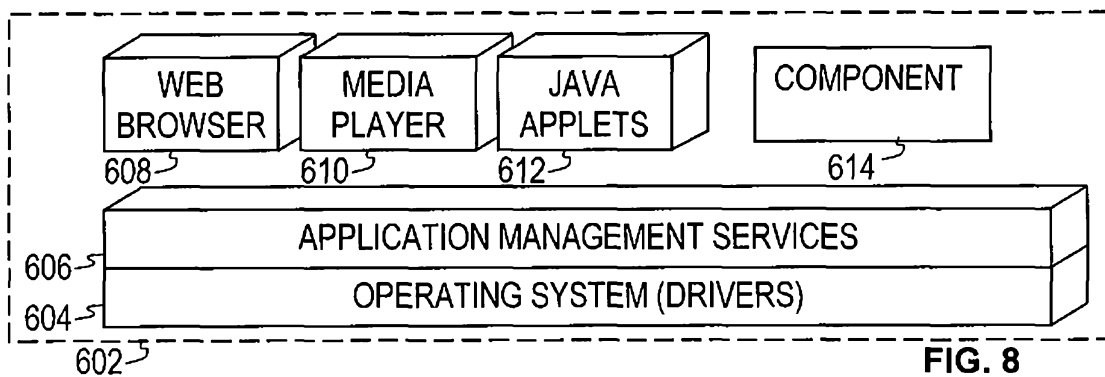
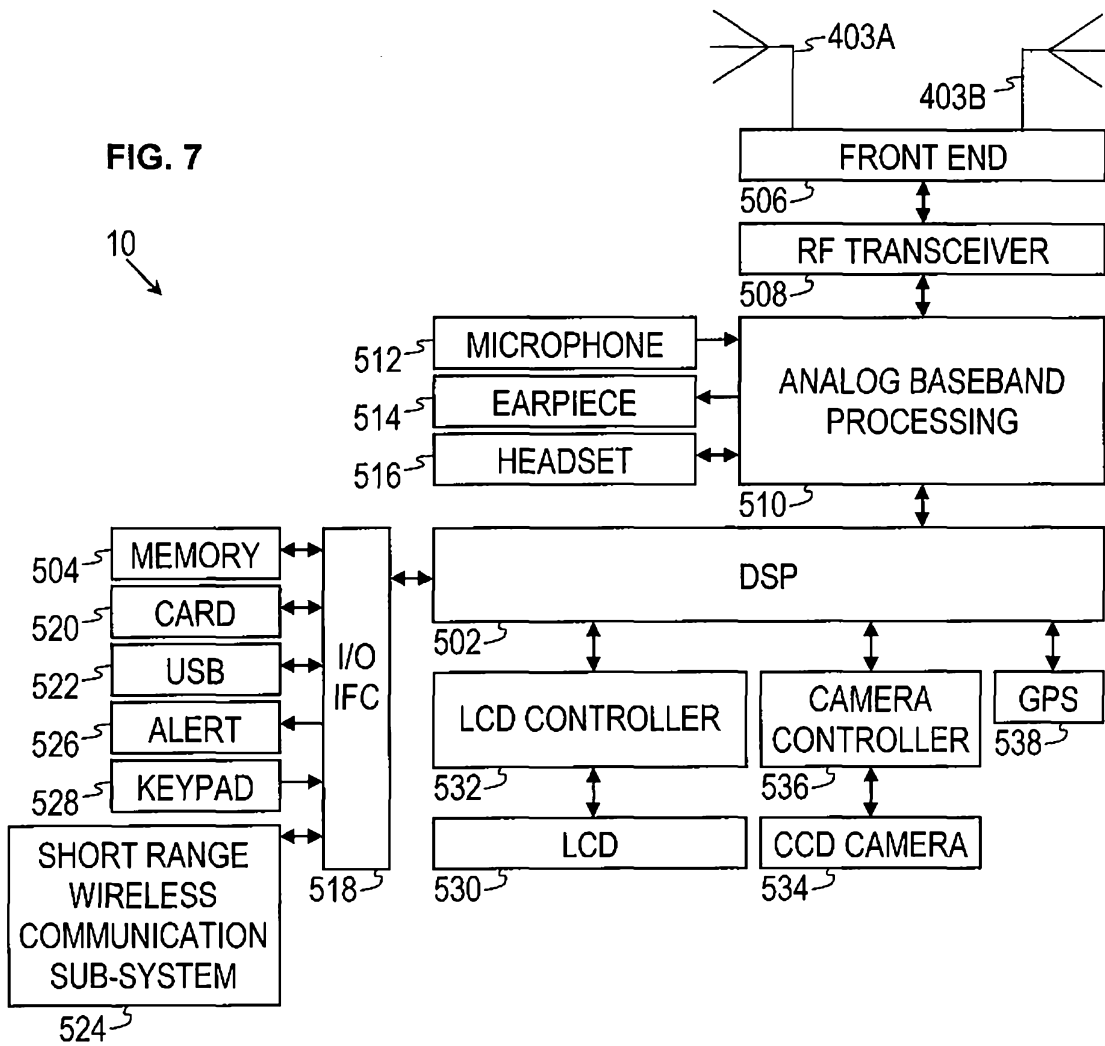

FIG. 5b

FIG. 6





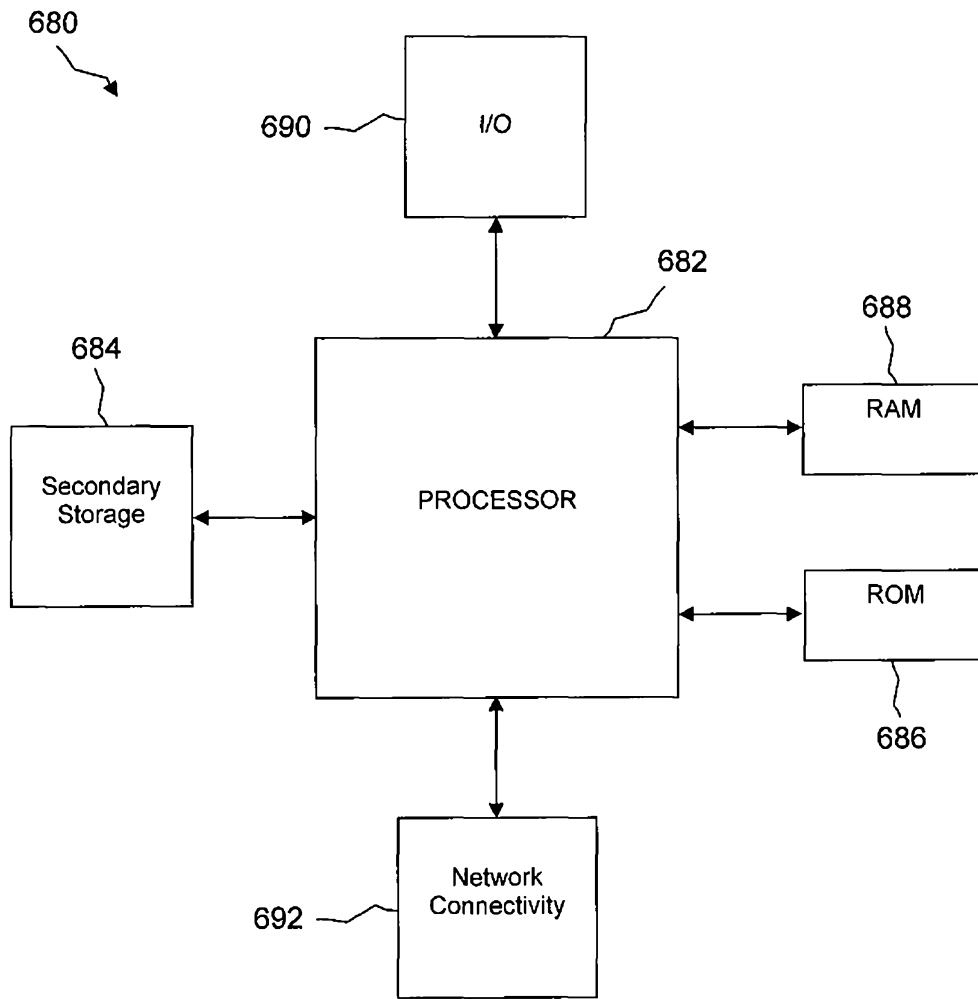

FIG. 9