

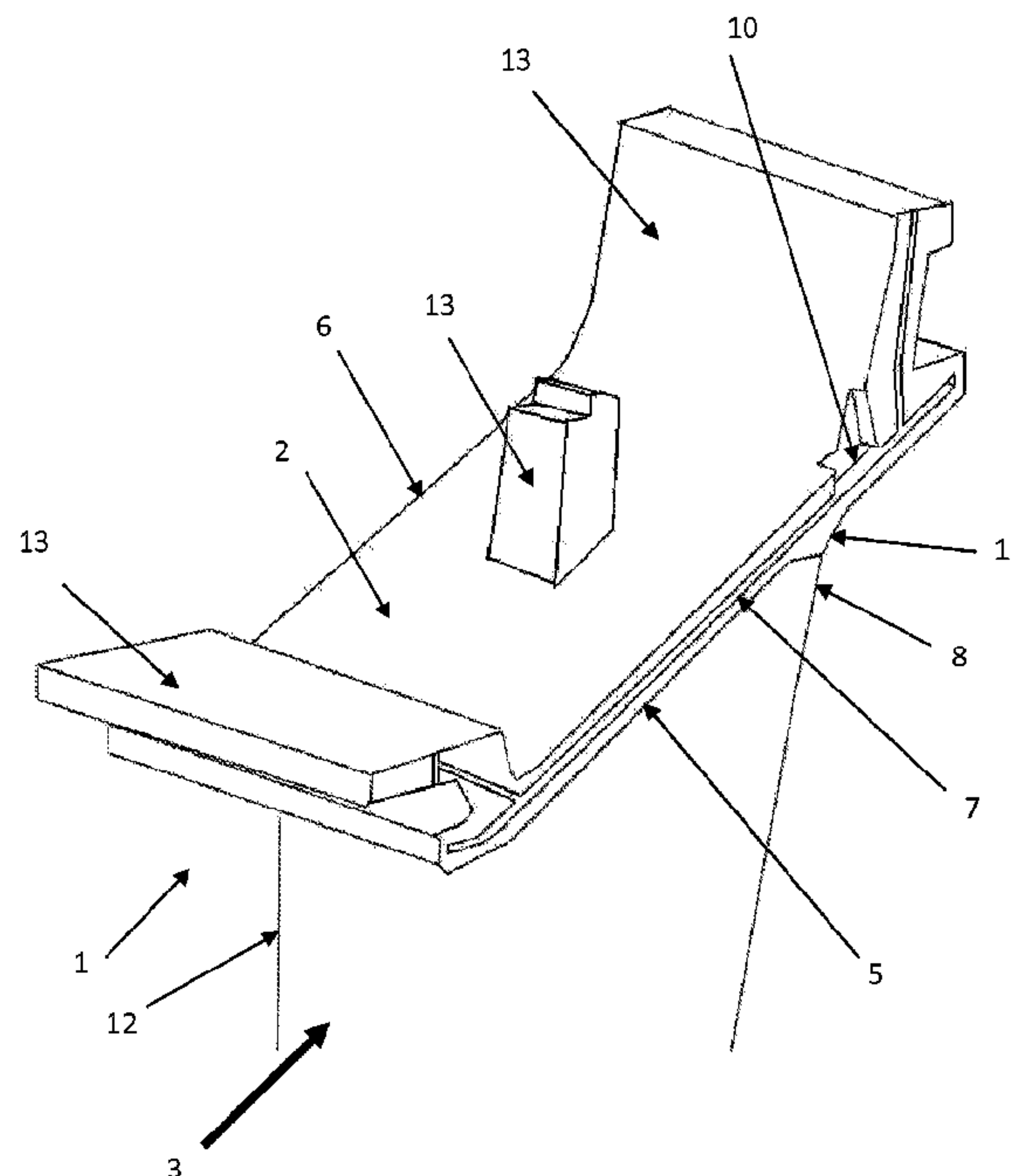

(86) **Date de dépôt PCT/PCT Filing Date:** 2008/06/23
 (87) **Date publication PCT/PCT Publication Date:** 2008/12/31
 (45) **Date de délivrance/Issue Date:** 2015/08/04
 (85) **Entrée phase nationale/National Entry:** 2009/12/15
 (86) **N° demande PCT/PCT Application No.:** EP 2008/057947
 (87) **N° publication PCT/PCT Publication No.:** 2009/000802
 (30) **Priorité/Priority:** 2007/06/28 (CH01044/07)

(51) **Cl.Int./Int.Cl. F01D 9/04** (2006.01),
F01D 11/00 (2006.01)
 (72) **Inventeurs/Inventors:**
KHANIN, ALEXANDER, RU;
KURGANOV, IGOR, RU;
VORONTSOV, SERGEY, RU;
ODINOKOV, VICTOR, RU
 (73) **Propriétaire/Owner:**
ALSTOM TECHNOLOGY LTD, CH
 (74) **Agent:** SMART & BIGGAR

(54) **Titre : AUBE DIRECTRICE POUR TURBINE A GAZ**
 (54) **Title: STATOR VANE FOR A GAS TURBINE ENGINE**



(57) **Abrégé/Abstract:**

The invention relates to a stator vane for a gas turbine engine, comprising a leading edge and a trailing edge and a vane platform extending at least between the leading edge and the trailing edge. The vane platform has first and second side walls extending substantially in the radial and axial directions of the gas turbine engine, whereby the first side wall, at least in the area of the trailing edge, is provided with a groove extending in the longitudinal direction of the vane platform for receiving a sealing plate, whereby the first side wall of the vane platform in the area of the trailing edge has a recess extending from the groove.

Abstract

The invention relates to a stator vane for a gas turbine engine, comprising a leading edge and a trailing edge and a vane platform extending at least between the leading edge and the trailing edge. The vane platform has first and second side walls extending substantially in the radial and axial directions of the gas turbine engine, whereby the first side wall, at least in the area of the trailing edge, is provided with a groove extending in the longitudinal direction of the vane platform for receiving a sealing plate, whereby the first side wall of the vane platform in the area of the trailing edge has a recess extending from the groove.

(Fig. 1)

Stator vane for a gas turbine engine

Field of technology

The present invention relates to a stator vane for a gas turbine engine, in particular a stator vane with a vane platform.

Prior art

In a gas turbine a plurality of stationary stator or guide vanes are used which are arranged in rows along the circumference of the turbine portion. As these stator vanes are subjected to the effects of the hot gases flowing out of the combustion chamber and of the high pressures, high stresses can arise in the stator vanes and the platforms. The platform is situated between the hot gas flow and space filled with cooling air. In order to seal this space from the hot gases the platform usually has side walls which are provided with a groove extending in the longitudinal direction of the platform. The grooves of two neighboring platforms (in the circumferential direction) receive a sealing plate extending between the two platforms. In some cases the distance, in the circumferential direction of the gas turbine, between the trailing edge of the stator vane and the groove can be very small. This can lead to considerable stress concentrations, particularly in the trailing edge of the stator vane and in the platform in the area of the trailing edge of the stator vane. Because of these stress concentrations the life time of the stator vane is significantly reduced.

79291-96

2

Summary of the invention

The invention may address these problems. The present invention aims to provide a stator vane for a gas turbine with a platform having a design, which may reduce the stress concentrations in the trailing edge of the stator vane and in the vane platform in the region of the trailing edge of the stator vane.

According to the invention these problems may be solved by providing a stator vane for a gas turbine having a vane platform. According to an aspect of the invention, there is provided a guide vane for a gas turbine, with a leading edge and a trailing edge and with a shroud which proceeds at least between the leading edge and the trailing edge and which has first and second side walls extending essentially radially and in the longitudinal direction of the gas turbine, at least the first side wall being provided, at least in the region of the trailing edge, with a groove for receiving a sealing plate, which groove proceeds in a longitudinal direction of the shroud, and having, in the region of the trailing edge, a clearance extending from the groove, wherein the depth of the clearance in the circumferential direction of the gas turbine is essentially equal to the depth of the groove, and in that the width of the clearance in the longitudinal direction of the shroud amounts to between once to three times its depth.

According to the invention a stator vane has a leading edge and a trailing edge and a platform extending at least between the leading and trailing edges. The platform has first and second side walls extending substantially in the axial and radial directions of the gas turbine. The first side wall is provided, at least in the area of the trailing edge, with a groove extending in the longitudinal direction of the platform for receiving a sealing plate, whereby the first side wall of the sealing plate in the area of the trailing edge has a recess extending from the groove.

The recess in the vane platform in the area of the trailing edge of the stator vane may reduce the stress concentrations in the trailing edge of the stator vane and in the vane platform in the area of the trailing edge of the stator vane. The low cycle fatigue and the creep rate in these areas may therefore be reduced.

79291-96

2a

In an advantageous embodiment of the invention the depth of the recess in the circumferential direction of the gas turbine is substantially the same as the depth of the groove. Through this, a considerable reduction in the stress concentrations

79291-96

3

may be observed in the trailing edge of the stator vane and in the vane platform in the area of the trailing edge of the stator vane.

The above and other objects, features and advantages of the invention will become more apparent from the following description of certain preferred embodiments thereof, when taken in conjunction with the accompanying drawings.

Short description of the drawings

The invention is described referring to an embodiment depicted schematically in the drawings, and will be described with reference to the drawings in more details in the following.

The drawings show schematically in:

- Figure 1 a perspective view of a stator vane with a platform according to an advantageous embodiment of the invention,
- Figure 2 a side view of a stator vane with a platform according to an advantageous embodiment of the invention
- Figure 3 the relationship between the trailing edge of the stator vane and the recess according to an advantageous embodiment of the invention,
- Figure 4 a sectional view of the platform in figure 2 through the line A-A,
- Figure 5 a side view of a prior art stator vane with a platform,

Figure 6 the relationship between the trailing edge of a prior art stator vane and the groove in the vane platform.

Detailed description of preferred embodiments

Figures 5 and 6 show a prior art stator vane 1 with a vane platform 2. In a gas turbine a plurality of such stationary stator vanes 1 are used, which are arranged in rows around the circumference of a turbine portion.

The stator vane 1 has a leading edge 12 and a trailing edge 8, whereby the vane platform 2 extends at least between the leading edge 12 and the trailing edge 8. Attachment elements 13 are provided on the radially outer side of the vane platform 2 for positioning the stator vane 1 in the radial and circumferential directions.

The vane platform 2 furthermore has side walls 5, 6 extending substantially in the longitudinal and radial directions of the turbine.

The vane platform 2 is located in the radial direction between a hot gas flow 3 and a space 4 filled with cooling air. In order to seal this space 4 from the hot gas flow the side walls 5, 6 are each provided with a groove 7 extending in the longitudinal direction of the vane platform 2. The grooves 7 of two neighboring vane platforms 2 receive a sealing plate which extends between the two vane platforms. A groove 7 extends in the axial direction of the gas turbine at least in the area of a trailing edge 8 of the stator vane 1, and the distance in the circumferential direction of the gas turbine between the trailing edge 8 of the stator vane 1 and the groove 7 can be very small, as can be seen from figure 6 which shows a cross section through a radially outer section of the vane portion together with a partial view in the area of the groove 7.

As the stator vane 1 is subjected, in use, to the effects of the hot gases 3 flowing out of the combustion chamber and the high pressures, high stress concentrations can arise in the trailing edge area of the stator vane 1 and in the vane platform 2 in the area of the trailing edge area of the stator vane 1. The life of the stator vane 1 is considerably reduced due to these stress concentrations in the area inside the circle 9 in figure 6. In figures 5 and 6 a stator vane 1 is provided with a radially outer vane platform. The stator vane 1 can however also be provided with a radially inner vane platform, which is similarly provided with a groove in the longitudinal direction of the vane platform, whereby in use stress concentrations arise in the trailing edge area of the stator vane 1 and in the radially inner vane platform in the region of the trailing edge 8 of the stator vane 1.

Figure 1 shows a stator vane 1 comprising a vane platform 2 according to a preferred embodiment of the invention. Similar elements are provided with similar reference numerals. According to the invention a first side wall 5 of the vane platform 2 in the area of the trailing edge 8 is provided with a recess 10 extending from the groove 7. In the preferred embodiment the recess 10 is provided directly opposite the trailing edge 8 in the longitudinal direction of the vane platform 2. The recess 10 preferably extends radially outwards and perpendicular to the groove 7. In particular only the first side wall 5 has such a recess 10.

The vane platform 2 can be provided with a raised portion 11 on the opposite side to the recess 10 in the radial direction, whereby the recess 10 is provided in the area of the raised portion 11 in the longitudinal direction of the vane platform 2. In particular, the recess 10 can be arranged in the area of a downstream end of the raised portion 11 in the longitudinal direction of the vane platform 2.

Referring to figure 3, which shows a cross section through a radially outer section of the vane portion together with a partial view in the area of the groove 7, it can be seen that the distance between the trailing edge 8 and the recess 10 in the

79291-96

6

circumferential direction of the gas turbine can be less than or equal to the depth of the groove 7. The stress concentrations however may be reduced in this area due to the recess 10 and therefore the low cycle fatigue and the creep rate in these areas may be reduced.

The depth of the recess 10 in the circumferential direction of the gas turbine is preferably substantially the same as the depth of the groove 7, as can be seen from figure 3. The width of the recess 10 in the longitudinal direction of the vane platform 2 is preferably between one and three times its depth and the profile of the recess is preferably substantially rectangular. The profile can however have other forms e.g. with side walls which extend at an angle to the longitudinal direction of the vane platform 2.

In figures 1 to 4 the stator vane is provided with a radially outer vane platform 2. The stator vane can however also be provided with a radially inner vane platform (not shown) which is similarly provided with a groove 7 extending in the longitudinal direction of the vane platform whereby, in use, stress concentrations arise in the trailing edge area of the stator vane and in the radially inner vane platform. In this case a first side wall of the radially inner platform in the area of the trailing edge 8 can be provided with a recess extending radially inwards from the groove 7.

The preceding description of the embodiments according to the present invention serves only an illustrative purpose and should not be considered to limit the scope of the invention.

Particularly, in view of the preferred embodiments, the man skilled in the art different changes and modifications in the form and details can be made without departing from the scope of the invention. Accordingly the disclosure of the current invention should not be limiting. The disclosure of the current invention should instead serve to clarify the scope of the invention which is set forth in the following claims.

List of references

- | | |
|----|--------------------|
| 1 | stator vane |
| 2 | platform |
| 3 | gas flow |
| 4 | space |
| 5 | first side wall |
| 6 | second side wall |
| 7 | groove |
| 8 | trailing edge |
| 9 | circle |
| 10 | recess |
| 11 | raised portion |
| 12 | leading edge |
| 13 | attachment element |

79291-96

8

CLAIMS:

1. A guide vane for a gas turbine, with a leading edge and a trailing edge and with a shroud which proceeds at least between the leading edge and the trailing edge and which has first and second side walls extending essentially radially and in
5 the longitudinal direction of the gas turbine, at least the first side wall being provided, at least in the region of the trailing edge, with a groove for receiving a sealing plate, which groove proceeds in a longitudinal direction of the shroud, and having, in the region of the trailing edge, a clearance extending from the groove, wherein the depth of the clearance in the circumferential direction of the gas turbine is essentially equal
10 to the depth of the groove, and the width of the clearance in the longitudinal direction of the shroud amounts to between once to three times its depth.
2. The guide vane as claimed in claim 1, wherein the clearance is provided in a radially outer shroud of the guide vane.
3. The guide vane as claimed in claim 1, wherein the clearance extends
15 radially outward essentially at right angles with respect to the groove.
4. The guide vane as claimed in claim 1, wherein the clearance lies essentially opposite the trailing edge in the longitudinal direction of the shroud.
5. The guide vane as claimed in claim 1, wherein the distance between the trailing edge and the clearance in the circumferential direction of the gas turbine
20 is smaller than the depth of the groove or is equal to the depth of the groove.
6. The guide vane as claimed in claim 1, wherein the profile of the clearance is a rectangular form.
7. The guide vane as claimed in claim 1, wherein that side of the shroud which lies opposite the clearance is provided with an elevation which is provided in
25 the region of the clearance.

79291-96

9

8. The guide vane as claimed in claim 1, wherein the clearance is provided in a radially inner shroud of the guide vane, the clearance extending radially inward essentially at right angles with respect to the groove.

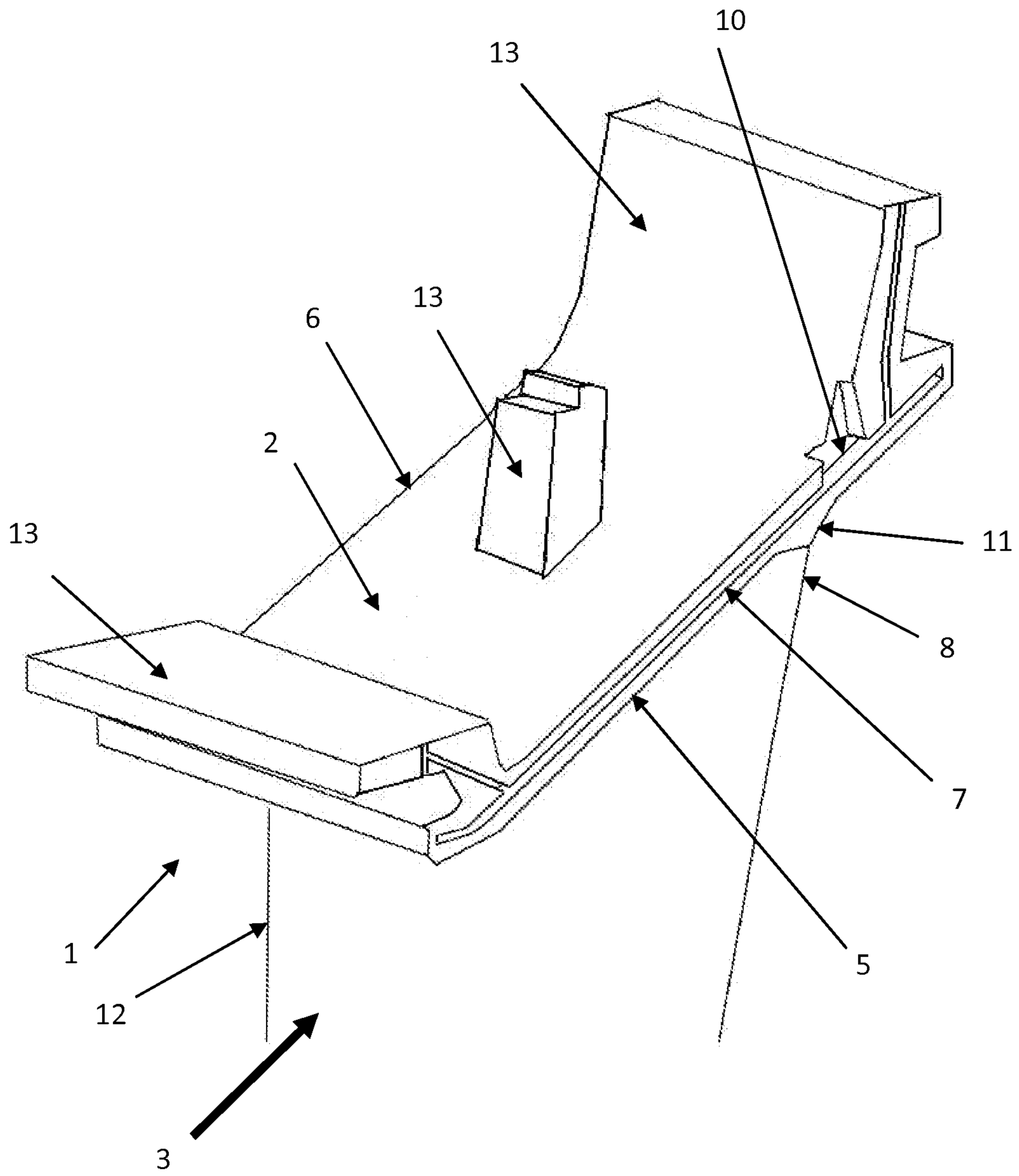

Fig. 1

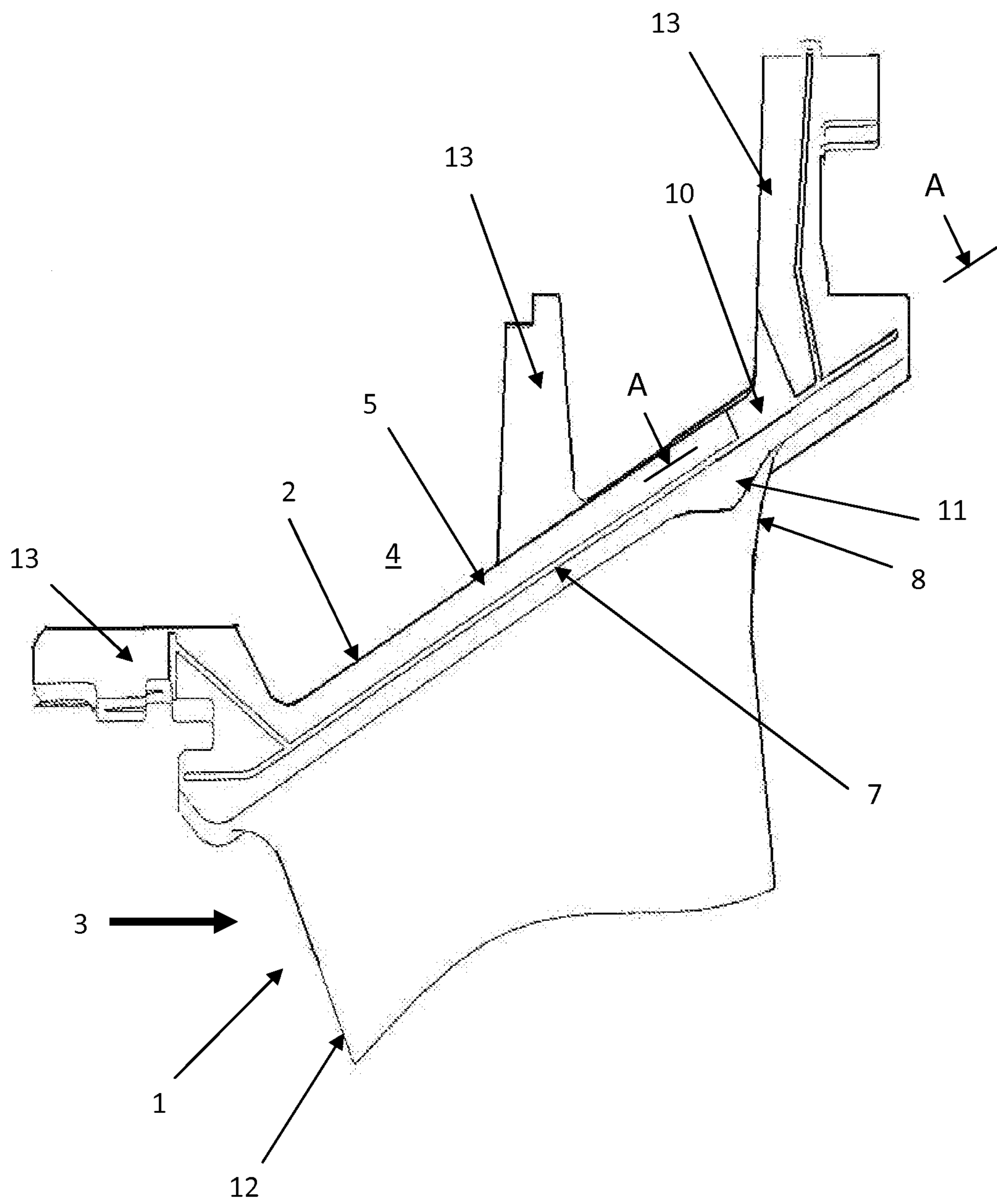

Fig. 2

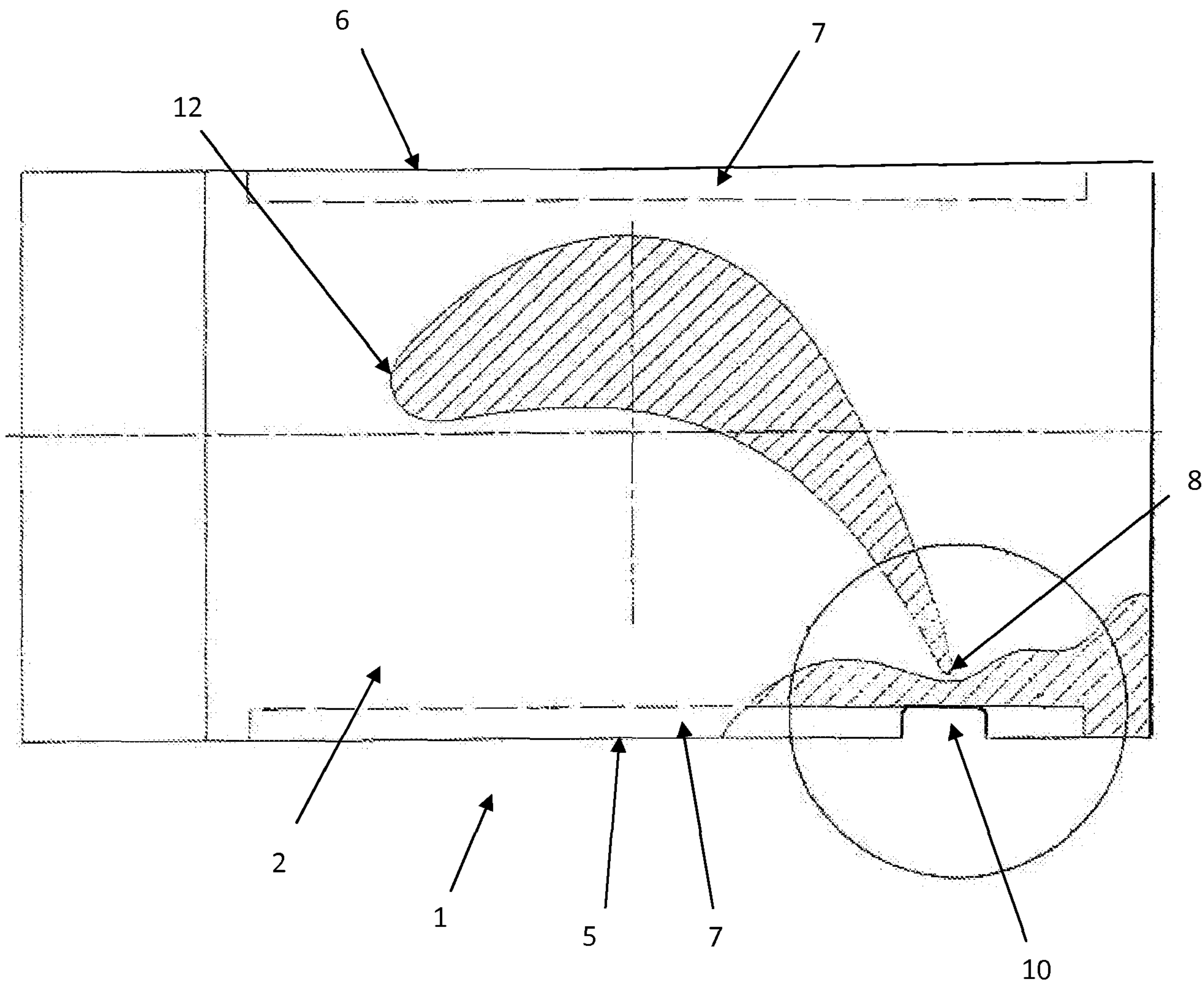

Fig. 3

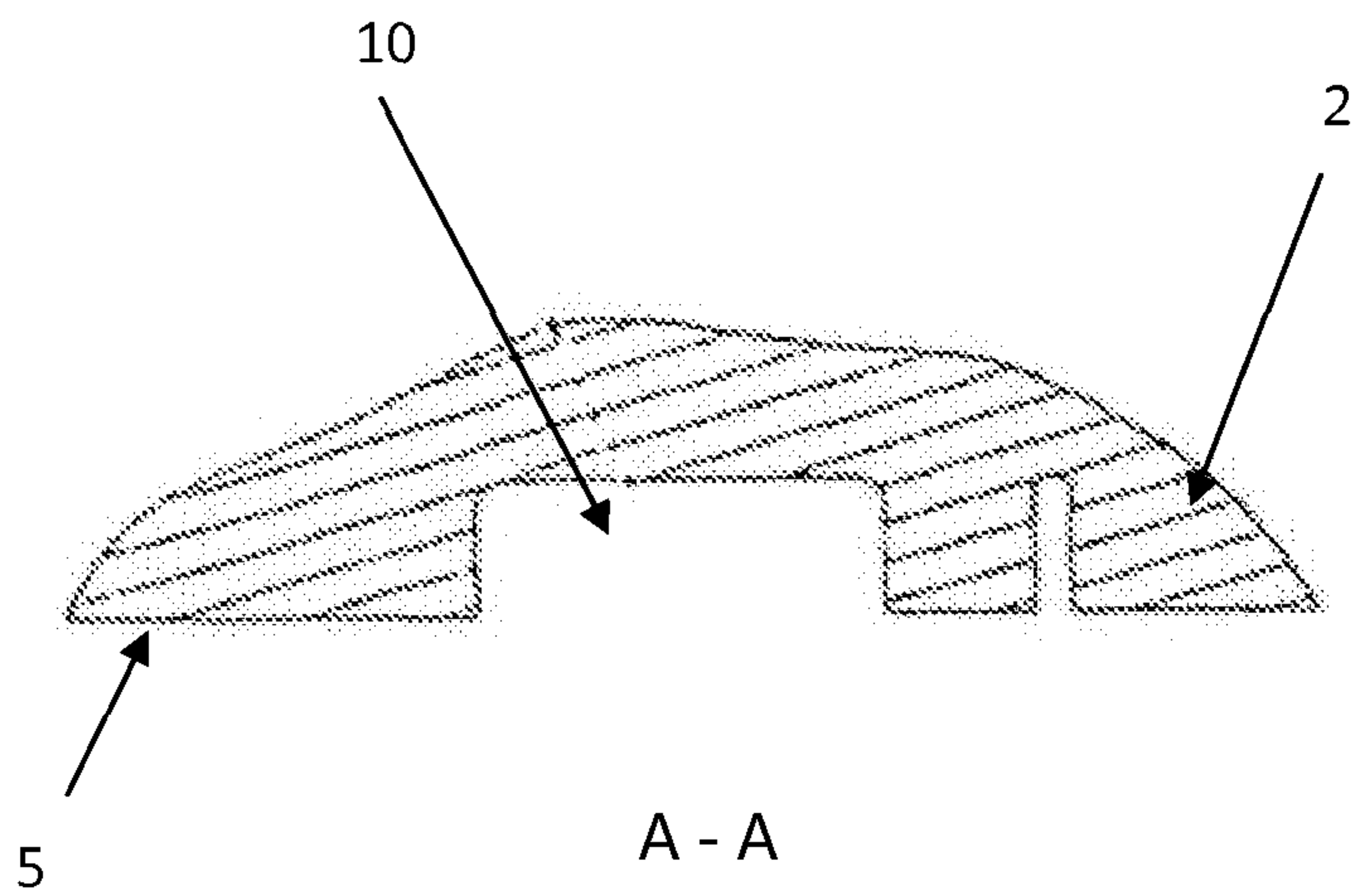

Fig. 4

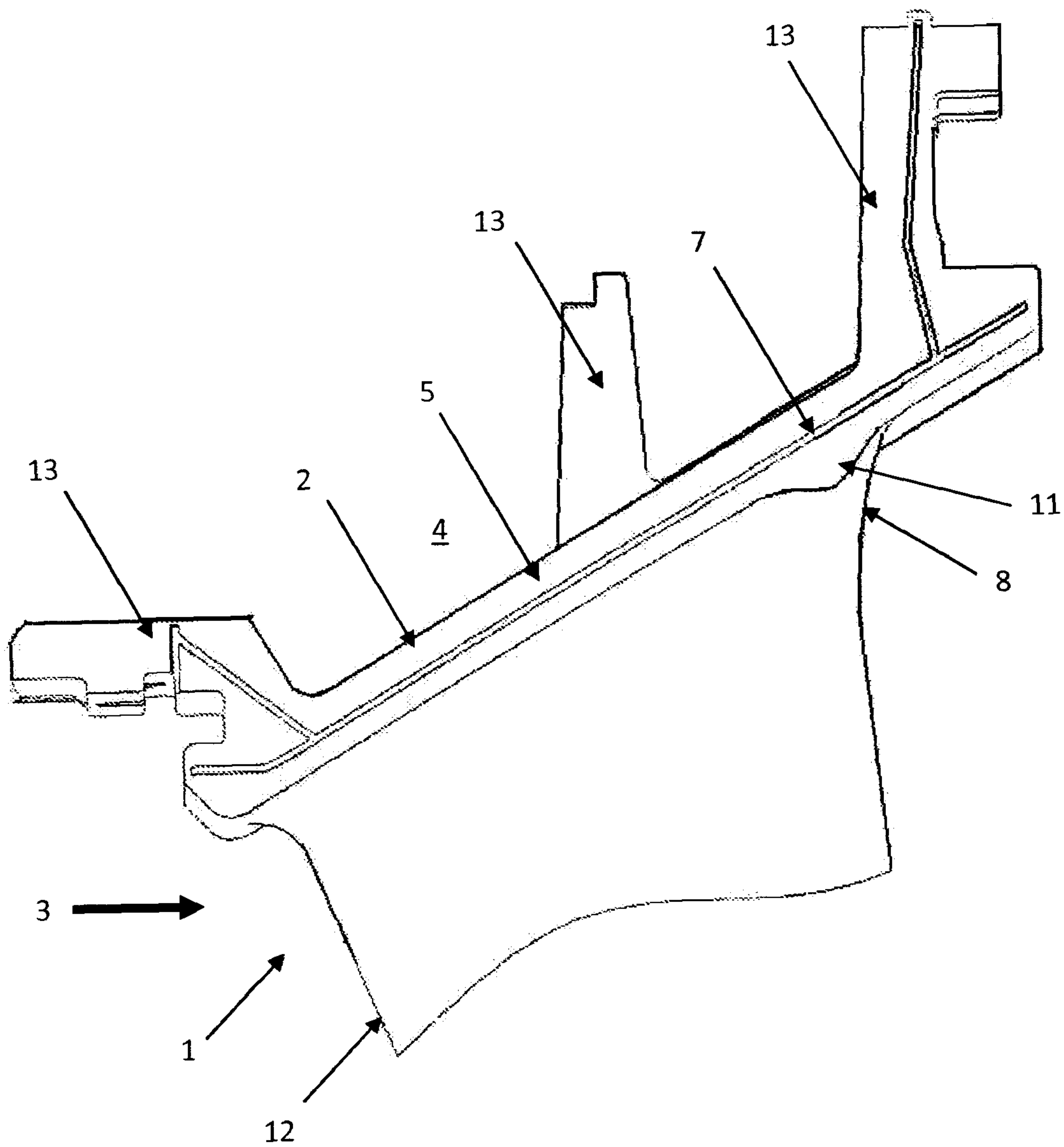

Fig. 5
(Prior Art)

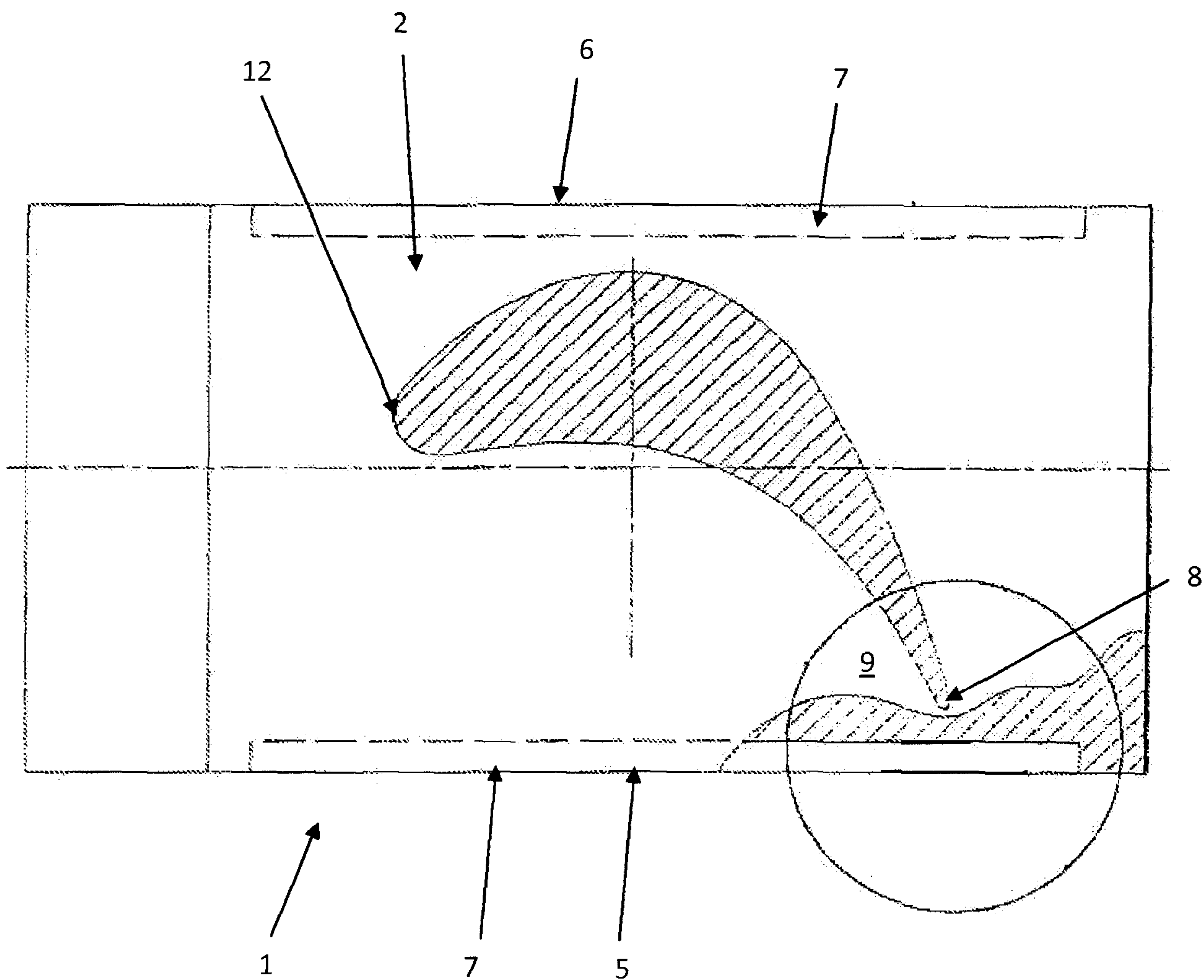

Fig. 6
(Prior Art)

