



(12) **EUROPEAN PATENT APPLICATION**

(43) Date of publication:
14.09.2022 Bulletin 2022/37

(51) International Patent Classification (IPC):
B66B 19/00 (2006.01)

(21) Application number: **22160857.3**

(52) Cooperative Patent Classification (CPC):
B66B 19/005; B66B 11/0045

(22) Date of filing: **08.03.2022**

(84) Designated Contracting States:
AL AT BE BG CH CY CZ DE DK EE ES FI FR GB GR HR HU IE IS IT LI LT LU LV MC MK MT NL NO PL PT RO RS SE SI SK SM TR
 Designated Extension States:
BA ME
 Designated Validation States:
KH MA MD TN

(72) Inventors:
 • **Yildiz, Oguzhan**
34445 Istanbul (TR)
 • **Ergen, Baris**
34662 Istanbul (TR)
 • **Selek, Mesut**
34896 Istanbul (TR)

(30) Priority: **08.03.2021 DE 102021105536**

(74) Representative: **Misselhorn, Hein-Martin**
Patent- und Rechtsanwalt
Am Stein 10
85049 Ingolstadt (DE)

(71) Applicant: **Wittur Holding GmbH**
85259 Wiedenzhausen (DE)

(54) **METHOD FOR MOUNTING AN ELEVATOR DRIVE**

(57) Method for mounting an elevator drive (2) in the shaft head of an elevator shaft (1), wherein the elevator drive (2) is lifted on a mounting slide (7) - consisting of a mounting bracket (9) and a counterweight (8) - by means of a lifting device (3) to the height of the intended mounting position above the elevator guide rails (4) and on a drive base frame (5) and is then moved from its position on the mounting bracket (9) into its exact intended mounting position, **characterized in that** a lifting device (3) is used which utilizes that space of the shaft (1) which is intended for the elevator car during operation.

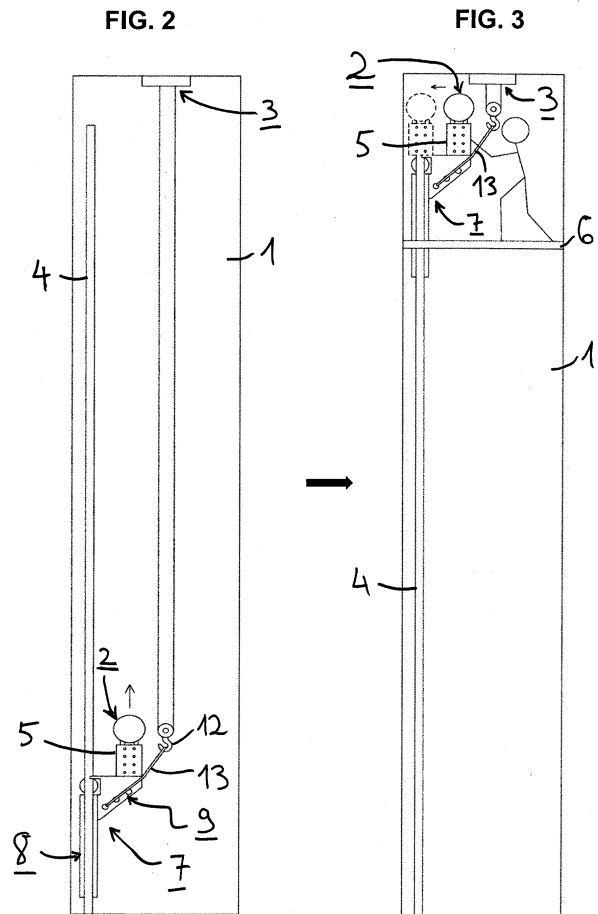

Description

[0001] The invention relates to a method for mounting an elevator drive in the shaft head of an elevator shaft in the manner of the generic term of claim 1, and to a system used for the corresponding mounting in the manner of the generic term of claim 5.

TECHNICAL BACKGROUND

[0002] Modern elevator systems are preferably implemented as "machine roomless elevator" (MRL) systems. This means that no additional machine room is required in the shaft head. On the one hand, this machine room is costly and, on the other, it mainly takes up space above or next to the shaft, which can be used for other purposes.

[0003] When installing the elevator drive, it has accordingly proved useful to install this elevator drive alone in the shaft head, preferably above and/or on the elevator guide rails of the elevator system. In order to save as much space as possible in the shaft head, this elevator drive is installed as close as possible to the shaft head ceiling.

[0004] For the installation of the elevator drive, a lifting device is usually used which is mounted - preferably temporarily - in the shaft head. Due to its positioning, it is not possible to lift the elevator drive to the desired position by means of the lifting device alone, directly under the shaft head ceiling, above the elevator guide rails.

[0005] Various methods and devices have already been proposed to solve this problem, but most of them are cumbersome or expensive to use.

STATE OF THE ART

[0006] For example, patent JP 2000 034072 A proposes a mounting device in which the lifting device used for mounting is placed on the side facing away from the elevator car in the space between the guide rails and the nearest shaft wall. This means that the shaft space provided for the elevator car is not impaired during installation and is available at this installation stage for a corresponding mobile working and transport platform.

[0007] However, this concept is accompanied by the fundamental problem that the lifting device used for the installation cannot be attached to the shaft head ceiling, or at least not without problems, since its rope running down the shaft runs the risk of getting in the way of the correct positioning of the elevator drive to be mounted at the top end of the guide rails.

[0008] For this reason, the said patent proposes to install the lifting device used for the installation on the guide rails near the shaft head but below the position in which the elevator drive is to be installed. In any case, this involves the problem that the maximum lifting height of the lifting device used for the installation is significantly below the position in the shaft head where the elevator drive is to be installed. In addition, in practice this type of instal-

lation is only possible without any problems if the lifting device used for installation is very compact. Moreover, it is usually necessary to temporarily install a bracket that connects the two guide rails and in the middle of which the lifting device used for installation can then be fixed. Otherwise, the lifting device must be operated in an unfavorable inclined lifting, which one tries to avoid because of the dangers involved. For these reasons, the patent in question also proposes to set up the lifting device required for the installation in the area of the shaft pit and to divert the lifting rope operated by it in the area of the shaft head via a pulley. This solves the problem of installation space in the shaft head, but does not eliminate the need for a bracket and does not solve the problem of the limited maximum lifting height.

[0009] The mounting method proposed by JP 2000 034072 A cannot be used where there is very little space between the counterweight guide rails and the shaft wall on the side facing away from the elevator car.

THE PROBLEM UNDERLYING THE INVENTION

[0010] In view of this, it is the object of the invention to specify means by which an elevator drive can be mounted easily and safely in the head area of an elevator shaft even if there is hardly any space available between the guide rails, on which the elevator drive is to be mounted, and the shaft wall on the side facing away from the elevator car - which may be mounted later.

THE INVENTIVE SOLUTION

[0011] According to the invention, this problem is solved with the features of the main claim directed to the method.

[0012] For this purpose, a special method is proposed for mounting an elevator drive in the shaft head of an elevator shaft. In this method, the elevator drive is lifted by means of a lifting device on a mounting slide - consisting of a mounting bracket and a counterweight - to the height of the intended mounting position, which is located above the elevator guide rails and on a drive base frame. The elevator drive is then moved from its position on the mounting bracket to its actual intended mounting position manually or fully or at least partially supported again by the lifting device.

[0013] The solution according to the invention is characterized by the use of a lifting device that utilizes the space of the shaft that is intended for the elevator car during operation.

[0014] The lifting device is thus preferably mounted in the center of the shaft and preferably temporarily on the shaft ceiling. This ensures that the elevator guide rails can be mounted as close as desired to the shaft wall. There is no need to provide additional clearance from the shaft wall for a lifting device and/or a component of the lifting device. Thus, the lifting device only uses the space that the elevator car travels in when operating as

intended. Because of the small distance between the elevator guide rails and the shaft wall, it is possible to maximize the horizontal dimensions of the elevator car.

[0015] Preferably, this maximization of the possible space for the car additionally increases both work safety and simplicity during the mounting. The space gained by the central lifting device can in fact also be used as space for the mounting work. The final - usually purely horizontal - movement of the elevator drive from its intended height to its intended installation position, as well as the attachment of the elevator drive to this final position, is usually carried out manually by a worker. This worker preferably takes up his working position on a fixed work platform in the shaft head area. Because of the additional space, the worker can move the elevator drive on the mounting bracket to the intended mounting position in a more relaxed and ergonomic position. Once the elevator drive has been positioned with sufficient accuracy, it can then be fixed in its final position. This can be done, for example, by aligning the through holes on the elevator drive and on the rail-mounted counterpart holding it so precisely that the retaining screws can be inserted and tightened.

[0016] If minimal alignment movements are still necessary, these can be carried out more easily and also more safely due to the additional space.

[0017] The term "shaft" or "elevator shaft" is characterized primarily by the fact that an elevator can travel in it. Thus, in a narrower sense, this term is used to describe a conventional shaft in the sense of an essentially closed, square travel tube. In its broader meaning, however, a "shaft" can also have a differently shaped shaft cross-section or otherwise shaped surrounding shaft walls, for example lattice constructions or the like.

[0018] The lifting device in question is usually a standard construction lifting device of a general type, often without special adaptation to an elevator. It is usually only temporary, until the installation work is completed on site. It can therefore be classified as an assembly tool. It is therefore usually not an additional elevator component that is included in the material costs of the elevator. In this context, the term "lifting device" within the meaning of the invention preferably includes a rope hoist, belt hoist or chain hoist. It is ideally equipped with a carrying tool. Preferably, this is in the form of a load hook, with the main task of lifting the load.

[0019] The "intended mounting position" within the meaning of the invention is preferably located at the upper end of the elevator guide rails. It is usually defined in such a way that the elevator drive is mounted ready for operation at already prefabricated mounting holes on the elevator guide rails or on the drive base frame, which is itself fixed to the elevator guide rails.

[0020] The said area of the shaft head lying below its intended installation position is, not only but in any case, an area lying less than 1.5 m below the underside of the shaft head ceiling or the end of the shaft head.

ANOTHER PROBLEM UNDERLYING THE INVENTION

[0021] Furthermore, it is an object of the invention to provide a system with which mounting of an elevator drive in the shaft head can be carried out easily and safely and with which, an additional horizontal space for the elevator car during operation can be created.

THE FURTHER INVENTIVE SOLUTION

[0022] The solution to the aforementioned problem is provided by means of a system with which the method of the type according to the invention can be carried out.

[0023] This system thus preferably includes a lifting device, an elevator drive and mounted elevator guide rails, at the upper end of which the elevator drive is to be mounted. In addition, the system includes a counterweight and a mounting bracket, which together form the mounting slide, and a drive base frame. This mounting slide is loaded with the elevator drive and moved by the lifting device to the height of its intended mounting position.

[0024] The system is characterized by the fact that the lifting device is mounted in the shaft in such a way that it uses the space of the shaft that is intended for the purposefully mounted elevator car in operation.

[0025] Thus, it is preferred that the lifting device is mounted centrally in the shaft and on the shaft ceiling.

[0026] The term "system" describes a totality of parts with the aid of which a method in the sense of the invention can be carried out.

[0027] The advantages mentioned in connection with the method described at the beginning can also be realized with the aid of such a system. The definitions of terms given at the beginning also apply here accordingly.

PREFERRED DESIGN OPTIONS

[0028] There are a number of ways in which the invention can be configured to further improve its effectiveness or usefulness.

[0029] Thus, it is particularly preferred to use in the method a spacer to the lifting device called "lifting aid" without any conceptual restriction, with which primarily a horizontal sometimes also a vertical distance between the position of the usually hook-shaped load suspension means of the lifting device and the position of the mounting bracket is to be compensated and bridged. This has the decisive advantage that the elevator drive to be mounted can pass the lifting device towards the end of the lifting process, so by passing it, it can reach a position in which the lifting device lies laterally next to the elevator drive to be mounted, although the lifting device is still active in lifting without restriction.

[0030] This avoids the unsafe and therefore undesirable tilting of the lifting rope or other comparable lifting means.

[0031] For mounting the lifting aid, holes are preferably used which are provided in the parts or bent components which form the mounting bracket. This lifting aid also preferably provides means of fixing the lifting device.

[0032] It is also preferred if the elevator drive and the drive base frame form a common assembly which is mounted before the lifting movement begins and this assembly is then attached to the mounting bracket before the lifting movement begins. Thus, it is preferred that only the drive base frame comes into direct contact with the mounting bracket. The result is that fixing the elevator drive in its final mounting position is simplified, since only the mounting bracket needs to be fixed to the elevator guide rails and the elevator drive is hereby automatically fixed as well.

[0033] Preferably, the method proceeds in such a way that the lifting movement in a purely vertical plane is sufficient to bring the elevator drive to the height of its intended mounting position. Thus, it is preferred that the interaction of a lifting aid and the lifting device results in the lifting device or its rope or comparable support means not colliding with the elevator drive or the mounting bracket in any position of the lifting motion. In this way, a generally safe lifting operation is possible and it can also be ensured that the intended height of the elevator drive is reached.

[0034] Preferably, the system according to the invention is designed such that the lifting aid has a substantially rigid design, such as that provided by a rod construction. Thus, the shape of the lifting aid does not substantially change during the lifting motion. In turn, this can prevent collision of the lifting aid with other components and ensure that the horizontal and/or vertical distance between the lifting aid and the mounting bracket is maintained. Furthermore, the lifting aid itself also does not collide with other components and possible entanglement in other components - as may be the case with a rope, for example - is prevented. This in turn leads to increased work safety.

[0035] Preferably, the lifting aid of the system is designed to allow the movement of the elevator drive on the mounting bracket, substantially horizontally, without substantial interference from the lifting aid. Since the elevator drive will be manually moved to its intended mounting position, substantially purely horizontally, in the course of the movement, it is preferred that the worker performing the movement have easy access to the elevator drive and that the path not be blocked by the lifting aid. On the one hand, this is possible by bringing the lifting aid close together in the area of the connection with the lifting device in such a way that the worker can easily reach past the lifting device on the left and right. On the other hand, this is possible in that the lifting aid in the area of the connection with the lifting device is designed in a projecting U-shape and the worker can reach through this U-shape.

[0036] This in turn ensures easier and more secure fixing in the intended mounting position.

[0037] It is also preferred that the mounting bracket of

the system is designed in such a way that it consists of at least two parallel opposite bent components attached to the counterweight. These bent components are preferably designed in such a way that they are shaped in a diametrically opposed manner - i.e. mirror-inverted. Furthermore, it is preferred that these bent components are simple sheet metal bending parts. However, manufacturing from other materials is also conceivable, which is why the parts are then no longer "bent". This design of the mounting bracket results in cost savings for the overall system and, in addition, in again simplified assembly.

[0038] Furthermore, it is preferred that the mounting bracket is designed in such a way that it offers the possibility of fixing the elevator drive and/or the drive base frame on the mounting bracket and also - after reaching the intended height

- being able to move it in such a way that an uncontrolled fall of the elevator drive and/or the drive base frame into the shaft is prevented during intended use.

[0039] Thus, it is preferred that the mounting bracket is equipped with oblong holes. The elevator drive or the mounting bracket

- on which the elevator drive is fixed - preferably have correspondingly suitable through holes through which at least 2 pairs of screws can be threaded. "Pair of screws" here means a set of screws, which are mounted on opposite sides of the mounting bracket, so corresponding screws on different bent components.

[0040] Before the lifting movement begins, it is now preferred to tighten the at least 2 pairs of screws with associated nuts to such an extent that it is no longer possible to move the elevator drive or the drive base frame. After completion of the lifting process - when the intended height is reached - the at least 2 pairs of screws are then loosened. It is preferable that these are only loosened to such an extent that displacement of the elevator drive or the drive base frame in the oblong holes can only take place in a "grinding" manner and the nuts are not removed. After the stop of the foremost pair of bolts is reached during horizontal movement to the intended mounting position, this pair can be completely loosened and removed. However, the at least one other pair must still remain in the grinding fixation.

[0041] Horizontal movement can then be continued until the elevator drive or mounting bracket can be fixed to the elevator guide rails. This fixing is carried out even before the loosening of the at least one other pair of screws. This prevents the elevator drive or the drive base frame from being temporarily unsecured during the entire mounting process. After this fixing to the elevator guide rails, the at least one pair of remaining screws can be removed from the oblong holes.

[0042] The "grinding" fixation thus means that signifi-

cantly increased work safety can be ensured. In addition, it also allows fine alignment movements to be carried out if necessary, thus facilitating mounting.

[0043] "Grinding" in the sense of the invention means that the screw connection is not completely loosened, but only the nuts are loosened slightly. This allows horizontal shifting - often only with increased force compared to when the screw connection is completely loosened.

[0044] Further advantageous design possibilities, modes of operation and advantages of the invention will now follow from the description of the preferred embodiments of the invention on the basis of the figures.

LIST OF FIGURES

[0045]

Fig. 1 shows a schematic diagram of the installation of an elevator drive in the shaft head area of an elevator shaft using only a lifting device and a worker.

Fig. 2 and Fig. 3 show a schematic side view of an elevator shaft showing the steps to be performed for installing an elevator drive in the shaft head area by means of the installation method according to the invention and the corresponding system.

Fig. 4 shows in spatial view and with detailed illustration of the exemplary individual parts of the system (without lifting device and without lifting aid) the individual subassemblies which must be assembled to carry out the method according to the invention.

Fig. 5 shows a three-dimensional view and a detailed illustration of the exemplary individual parts (without lifting device and lifting aid) of the assembled system for carrying out the procedure for mounting the elevator drive.

Fig. 6 shows a three-dimensional view of the two bent components used to form the mounting bracket.

PREFERRED EMBODIMENTS

[0046] First of all, Fig. 1 shows a side view of an elevator shaft 1 in which the mounting of an elevator drive 2 is carried out only by means of a lifting device 3 and a schematically depicted worker. At the same time, Fig. 1 visualizes the typical problem: The end of the elevator guide rails on which the elevator drive 2 is to be mounted is so close under the shaft head ceiling that the drive cannot be lifted into its intended mounting position with the aid of the lifting device alone.

[0047] The worker must therefore manually move the elevator drive to the end of the elevator guide rails 4 (shown by arrow) in order to be able to attach it there to the drive base frame 5 at the upper end of the elevator guide rails. This is the intended mounted position (shown

by dashed elevator drive). Often, the worker is not only confronted with the problem of having to lift the drive the last bit by hand into its mounting position. Relatively often, he even has the additional problem of having to align the elevator drive in a forced position just below the shaft head ceiling in order to align all the mounting holes so that he can screw the drive tight.

[0048] Fig. 2 and Fig. 3 show in side view of an elevator shaft a schematic execution of the steps to be performed for the mounting of an elevator drive in the shaft head area by means of the mounting method according to the invention and the corresponding system. The sequence is indicated by the thick black arrow.

[0049] First, Fig. 2 illustrates the preparations made in the method according to the invention.

[0050] First, an elevator or counterweight guide rail string of elevator guide rails 4, on which the elevator drive 2 is to be mounted, is set up.

[0051] It can be advantageous if, at this stage of the process, the second elevator guide rail for the counterweight or the car (depending on where the drive is to be fixed) has not yet been erected. This can be particularly useful in the case of narrow shafts. It is then possible to work as unhindered as possible in the shaft and, in particular, the elevator drive can then be raised largely freely.

[0052] The mounting slide 7 is then mounted on the elevator guide rails 4. Preferably, the elevator guide rails 4 are used to support the elevator drive 2 in its intended mounting position. As can be seen well from Fig. 2, the mounting slide is composed of two different assemblies. On the one hand, the counterweight 8, whereby this represents a complete frame construction (see Fig. 4 and Fig. 5). On the other hand, the mounting slide also comprises the mounting bracket 9, which preferably consists of two parallel steel or bent components 10 (see Fig. 4 and Fig. 5). This mounting bracket is attached to the counterweight, which itself has been movably mounted between the elevator guide rails 4. As one can see the mounting bracket protrudes - more than insignificantly, in most cases across the safety distance - into the shaft area in which the elevator car will travel later on.

[0053] Then, preferably, the assembly consisting of the elevator drive 2 and the drive base frame 5 is firmly fixed to the mounting bracket 9 (with at least 2 pairs of screws).

Fig. 4 again shows the various assemblies individually and Fig. 5 in the assembled state.

[0054] It can also be seen here that the elevator drive 2 preferably comprises the motor, a traction sheave and the feet.

[0055] The preparatory steps also include mounting the lifting device 3 in the area of the shaft head or on the shaft head ceiling, as also shown in Fig. 2.

[0056] The lifting device 3 must then be connected to the mounting slide 9. The lifting aid 13, which must be attached to the mounting bracket 9 beforehand, is preferably used for this purpose.

[0057] The lifting aid 13 is then attached to the lifting device 3, usually to the load hook 12. Sometimes a lifting

gear not shown in the figure is used for this purpose.

[0058] The elevator drive 2 is then lifted up the shaft 1 until it reaches the position shown in Fig. 3. This is the intended installation height. Now a temporary work platform 6 can be erected, at a height at which the worker can work ergonomically. The worker must move the elevator drive 2 or the assembly consisting of the elevator drive 2 and the drive base frame 5 into its intended mounting position (shown dashed in Fig. 3) essentially purely horizontally. The worker thus preferably carries out the assembly steps already mentioned for fixing to the elevator guide rails 4:

[0059] "After completion of the lifting operation - when the intended height has been reached - the at least 2 pairs of screws are loosened. It is preferable that these are only loosened to such an extent that movement of the elevator drive or the drive base frame in the oblong holes can only take place "grinding" and the nuts are not removed. After the stop of the foremost pair of screws is reached during horizontal movement to the intended mounting position, this pair can be completely loosened. However, the at least one other pair must still remain in the grinding fixation.

[0060] Horizontal movement can then be continued until the elevator drive or mounting bracket can be fixed to the elevator guide rails. This fixation is carried out even before the loosening of at least one other pair of screws. This optionally ensures that the elevator drive or the drive base frame are always secured during the entire installation. After this fixation to the elevator guide rails, the at least one pair of remaining screws can be removed from the oblong holes. "

[0061] Fig. 6 also shows the mounting bracket 9 of the system according to the invention. This consists of two bent components 10, each of which has the oblong hole 11 already mentioned.

OF REFERENCE SIGNS

[0062]

- | | |
|----|--|
| 1 | Elevator shaft |
| 2 | Elevator drive |
| 3 | Lifting device |
| 4 | Elevator guide rails |
| 5 | Drive base frame |
| 6 | Work platform |
| 7 | Mounting slide |
| 8 | Counterweight |
| 9 | Mounting bracket |
| 10 | Bent component of the mounting bracket |
| 11 | Oblong hole of a bent component |
| 12 | Load hook of the lifting device |
| 13 | Lifting aid |

Claims

1. Method for mounting an elevator drive (2) in the shaft head of an elevator shaft (1), wherein the elevator drive (2) is lifted on a mounting slide (7) - consisting of a mounting bracket (9) and a counterweight (8) - by means of a lifting device (3) to the height of the intended mounting position above the elevator guide rails (4) and on a drive base frame (5) and is then moved from its position on the mounting bracket (9) into its exact intended mounting position, **characterized in that** a lifting device (3) is used which utilizes that space of the shaft (1) which is intended for the elevator car during operation.
2. Method for mounting an elevator drive (2) according to one of the preceding claims, **characterized in that** a horizontal and/or vertical distance between the position of the lifting device (3) and the position of the mounting bracket (9) is compensated by a lifting aid (13).
3. Method for mounting an elevator drive (2) according to claim 1, **characterized in that** the assembly consisting of elevator drive (2) and drive base frame (5) is already mounted before the start of the lifting movement and this assembly is fastened to the mounting bracket (9) before the start of the lifting movement.
4. Method for mounting an elevator drive (2) according to one of the preceding claims, **characterized in that** the lifting movement of the lifting device (3) in a purely vertical plane is sufficient to bring the elevator drive (2) to the height of its intended mounting position.
5. System for mounting an elevator drive (2) in the shaft head of an elevator shaft (1), the system comprising a lifting device (3), an elevator drive (2), elevator guide rails (4) mounted in an elevator shaft (1) - at the upper end of which the elevator drive (2) is to be mounted -, a counterweight (8), a mounting bracket (9) and a drive base frame (5), **characterized in that** the lifting device (3) is mounted in the shaft (1) in such a way that it utilizes that space of the shaft (1) which is intended for the elevator car during operation.
6. System for mounting an elevator drive (2) according to claim 4, **characterized in that** the lifting aid (13) has a substantially rigid design, such as in a rod construction.
7. System for mounting an elevator drive (2) according to claim 4, **characterized in that** the lifting aid (13) is designed in such a way that a substantially horizontal sliding of the elevator drive (2) on the mounting bracket (9) is possible without a substantial interfer-

ence by the lifting aid (13).

8. System for mounting an elevator drive (2) according to one of the preceding claims, **characterized in that** the mounting bracket (9) is designed in such a way that it consists of at least two parallel opposite bent components (10) fixed to the counterweight (8). 5
9. System for mounting an elevator drive (2) according to one of the preceding claims, **characterized in that** the mounting bracket (9) is designed in such a way that it allows the elevator drive (2) and/or the drive base frame (5) to be mounted on the mounting bracket (9) and, moreover, to be moved in such a way that uncontrolled falling of the elevator drive (2) and/or the drive base frame (5) into the shaft (1) is prevented during intended use. 10 15

20

25

30

35

40

45

50

55

FIG. 1

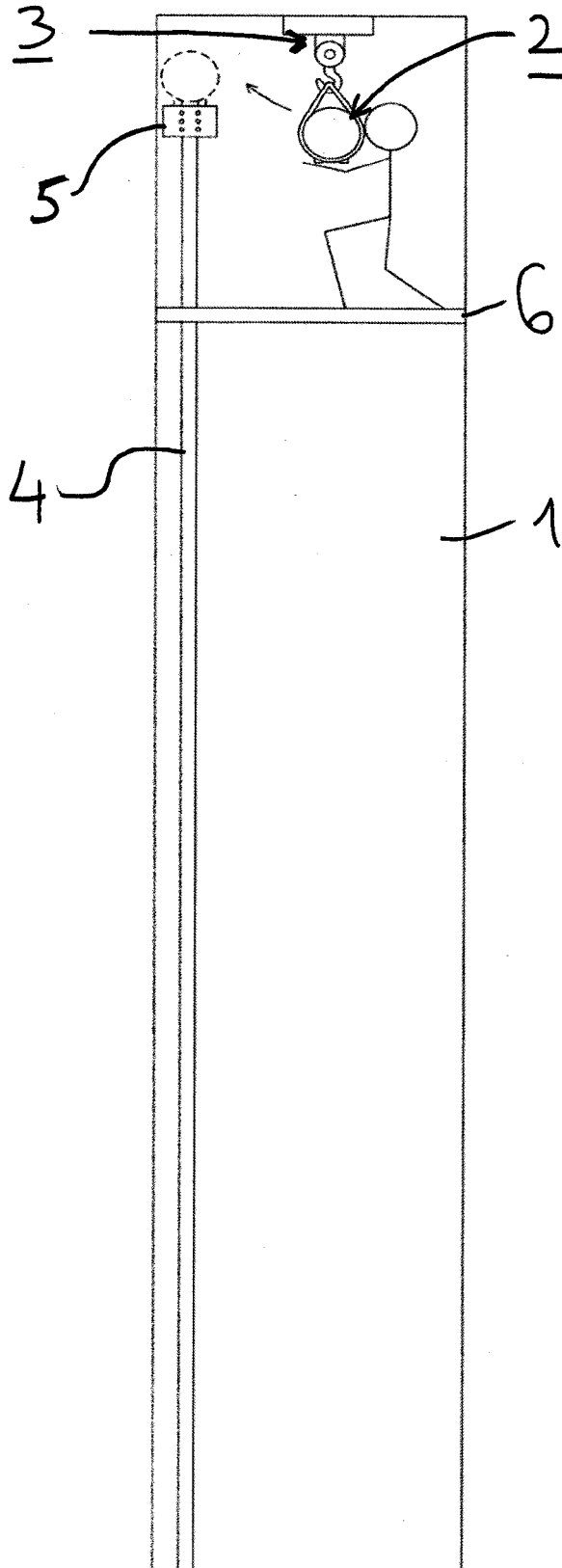

FIG. 2

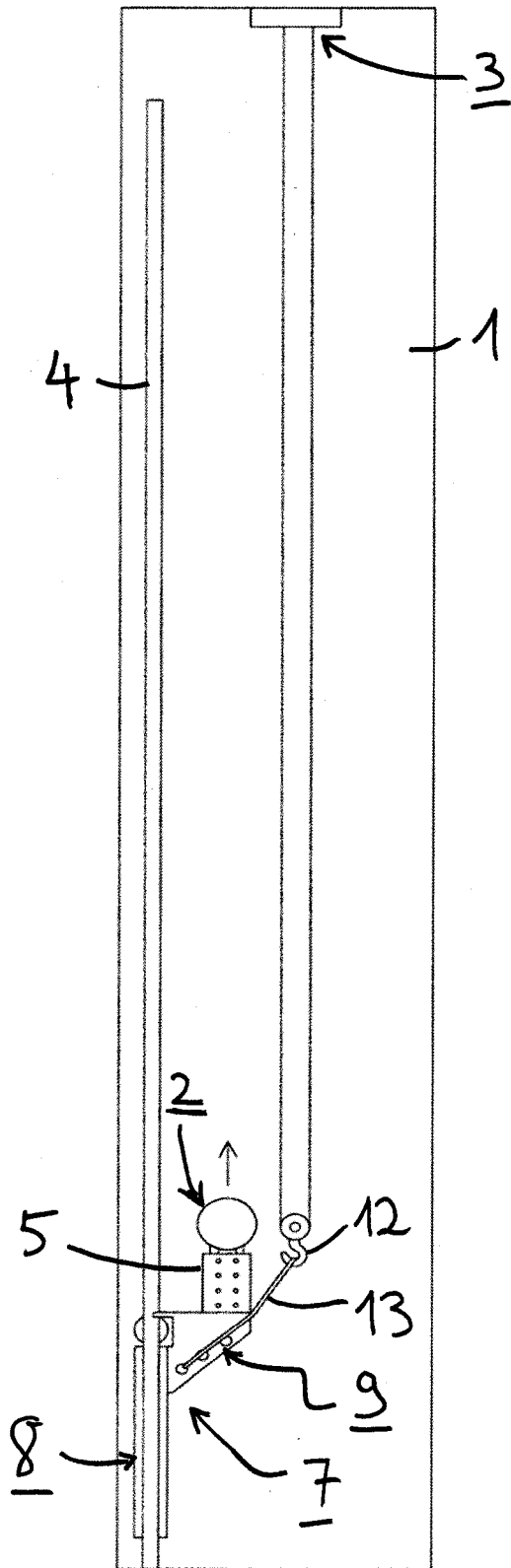

FIG. 3

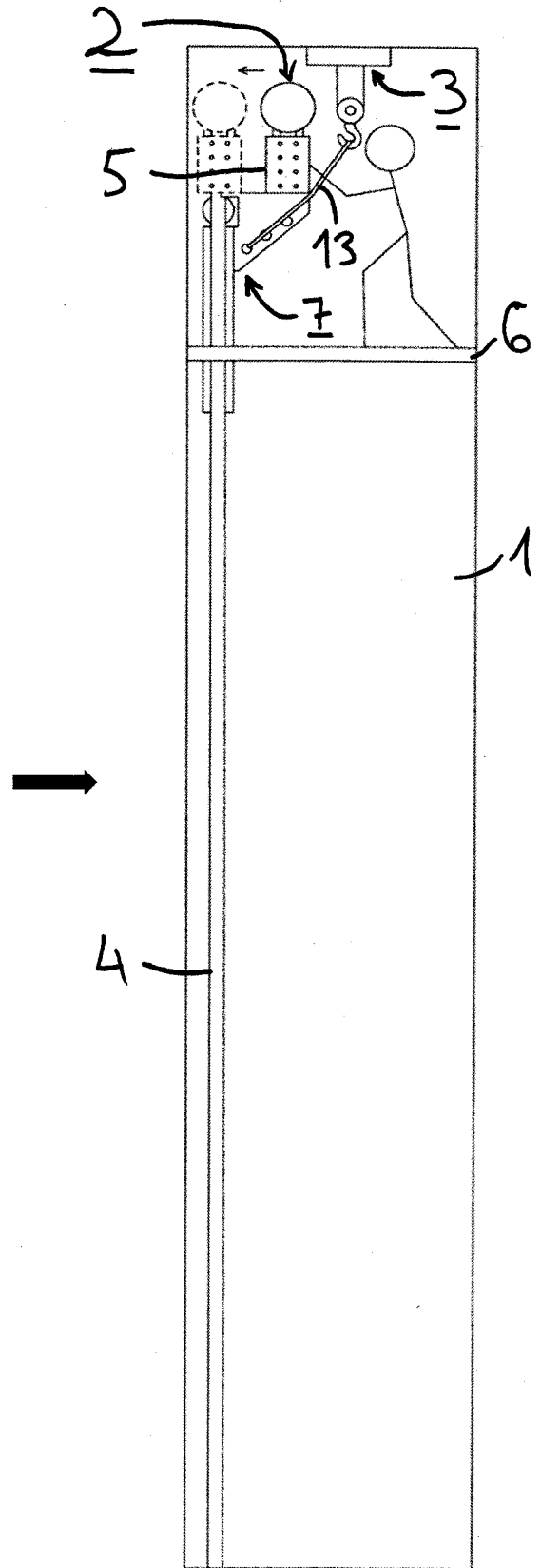

FIG. 4

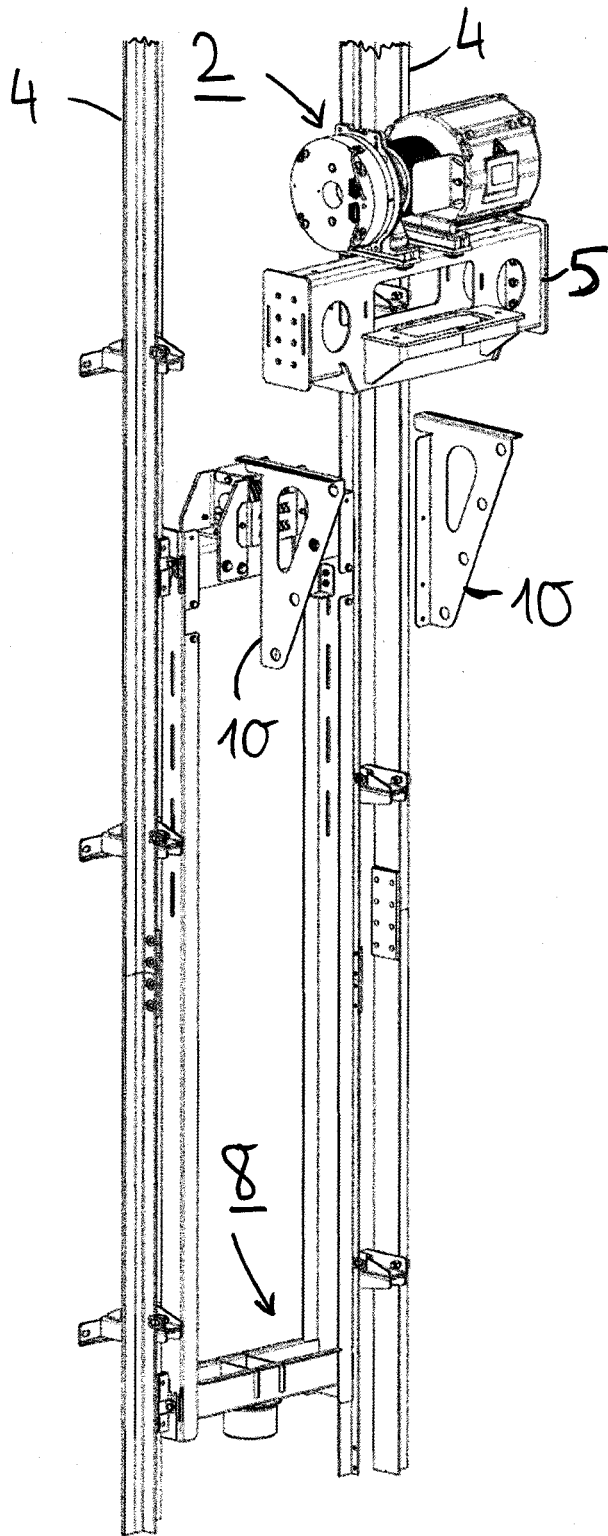

FIG. 5

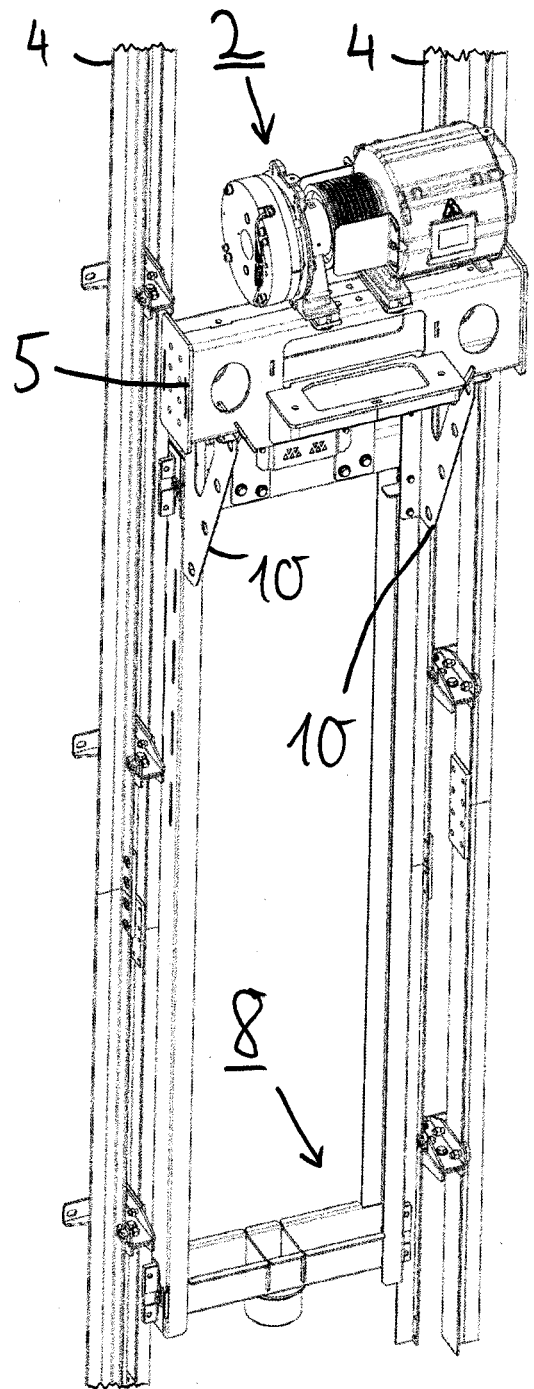
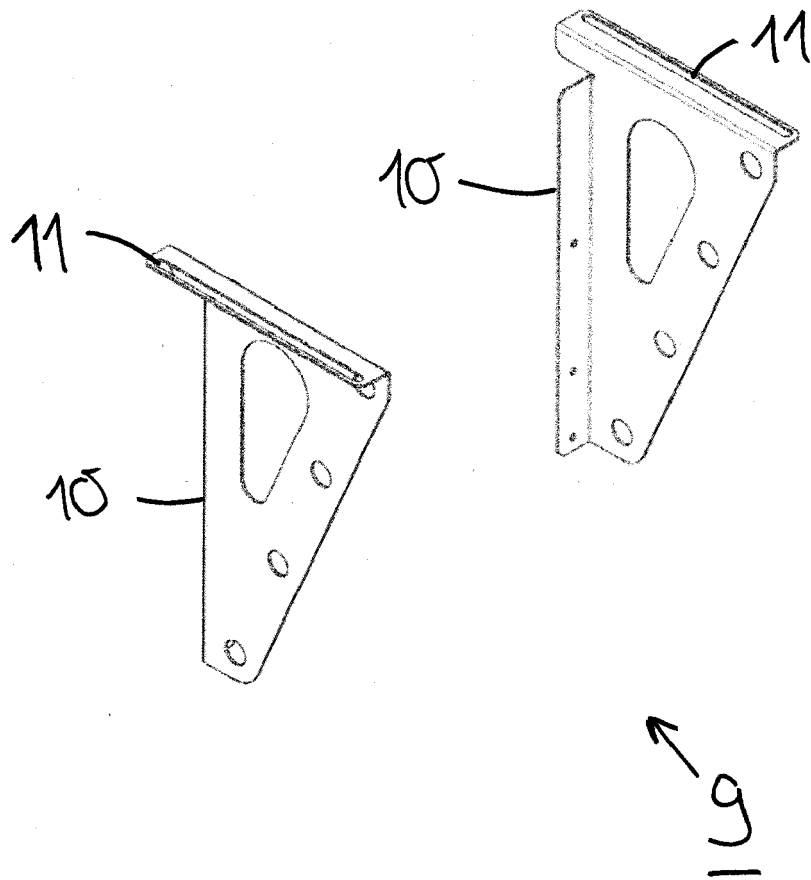

FIG. 6





EUROPEAN SEARCH REPORT

Application Number

EP 22 16 0857

5

10

15

20

25

30

35

40

45

DOCUMENTS CONSIDERED TO BE RELEVANT

Category	Citation of document with indication, where appropriate, of relevant passages	Relevant to claim	CLASSIFICATION OF THE APPLICATION (IPC)
X	US 10 252 889 B2 (BRUNO GILLES [FR]; GREUIN JACQUES [FR] ET AL.) 9 April 2019 (2019-04-09) * abstract; figures 1-7 * * column 3, line 50 - column 6, line 57 * -----	1-9	INV. B66B19/00
X	JP 2012 201497 A (TOSHIBA ELEVATOR CO LTD) 22 October 2012 (2012-10-22) * abstract; figures 2-11 * * paragraphs [0011] - [0043] * -----	1-9	
X,D	JP 2000 034072 A (HITACHI BUILDING SYS CO LTD) 2 February 2000 (2000-02-02) * abstract; figures 1-8 * -----	1-9	
X	US 2020/283271 A1 (MORSE JUSTIN CHARLES [US] ET AL) 10 September 2020 (2020-09-10) * figures 1-7 * * paragraphs [0013] - [0033] * -----	5-9	
			TECHNICAL FIELDS SEARCHED (IPC)
			B66B

The present search report has been drawn up for all claims

1

50

Place of search The Hague	Date of completion of the search 25 July 2022	Examiner Bleys, Philip
-------------------------------------	---	----------------------------------

55

EPO FORM 1503 03:82 (P04C01)

CATEGORY OF CITED DOCUMENTS
 X : particularly relevant if taken alone
 Y : particularly relevant if combined with another document of the same category
 A : technological background
 O : non-written disclosure
 P : intermediate document

T : theory or principle underlying the invention
 E : earlier patent document, but published on, or after the filing date
 D : document cited in the application
 L : document cited for other reasons

 & : member of the same patent family, corresponding document

**ANNEX TO THE EUROPEAN SEARCH REPORT
ON EUROPEAN PATENT APPLICATION NO.**

EP 22 16 0857

5 This annex lists the patent family members relating to the patent documents cited in the above-mentioned European search report.
The members are as contained in the European Patent Office EDP file on
The European Patent Office is in no way liable for these particulars which are merely given for the purpose of information.

25-07-2022

Patent document cited in search report	Publication date	Patent family member(s)	Publication date
US 10252889 B2	09-04-2019	CN 104321268 A	28-01-2015
		EP 2844600 A1	11-03-2015
		ES 2633592 T3	22-09-2017
		US 2015083525 A1	26-03-2015
		WO 2013165411 A1	07-11-2013

JP 2012201497 A	22-10-2012	NONE	

JP 2000034072 A	02-02-2000	NONE	

US 2020283271 A1	10-09-2020	NONE	

EPO FORM P0459

For more details about this annex : see Official Journal of the European Patent Office, No. 12/82

REFERENCES CITED IN THE DESCRIPTION

This list of references cited by the applicant is for the reader's convenience only. It does not form part of the European patent document. Even though great care has been taken in compiling the references, errors or omissions cannot be excluded and the EPO disclaims all liability in this regard.

Patent documents cited in the description

- JP 2000034072 A [0006] [0009]