

Jan. 1, 1924

1,479,593

F. C. FANTZ

BARREL HOISTING APPARATUS

Filed Dec. 13, 1919

2 Sheets-Sheet 1

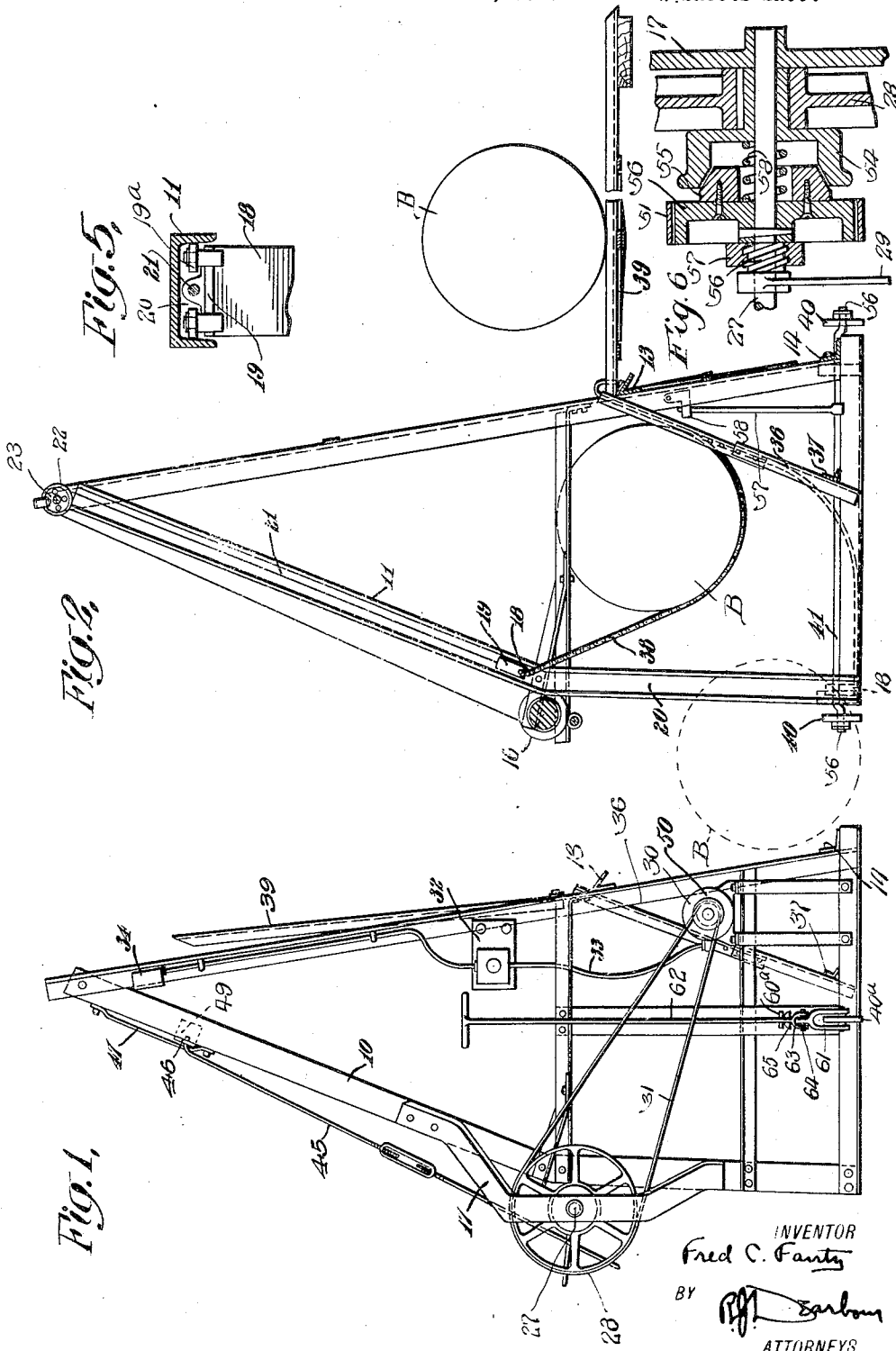

Fig. 1.

Fig. 2.

Fig. 5.

INVENTOR
 Fred C. Fantz
 BY *[Signature]*
 ATTORNEYS

UNITED STATES PATENT OFFICE.

FRED C. FANTZ, OF PORT ARTHUR, TEXAS, ASSIGNOR TO THE TEXAS COMPANY, A CORPORATION OF TEXAS.

BARREL-HOISTING APPARATUS.

Application filed December 13, 1919. Serial No. 344,510.

To all whom it may concern:

Be it known that I, FRED C. FANTZ, a citizen of the United States, residing at Port Arthur, in the county of Jefferson and State of Texas, have invented certain new and useful Improvements in Barrel-Hoisting Apparatus, of which the following is a specification.

My invention relates to hoisting apparatus for elevating and loading barrels, bales or packages and particularly to such as is adapted for loading heavy barrels or bales into freight cars.

One object of my invention is to provide a simple, durable and efficient hoist of the aforesaid character that shall be power operated, readily portable, and capable of continuous and rapid operation.

It is a comparatively simple and easy matter to load barrels into box cars from a loading platform substantially flush with the car floor up to the point when a single tier of barrels covers the entire car floor. It is then difficult and a relatively slow process to raise barrels of oil or other heavy barrels or bales onto the upper tier.

According to my invention I provide a simple hoist which is adapted to raise the barrels, bales or the like, very quickly and easily, and, if desired, at a continuous and uniform rate to the level of the upper tier or to some other predetermined height thereby decreasing the cost and increasing the speed of loading. The apparatus is also well adapted for unloading and for various other purposes.

In order that my invention may be thoroughly understood I will now proceed to describe an illustrative and preferred embodiment of the same in the following specification, and will then point out the novel features in appended claims:

Referring to the drawings:

Figure 1 is a side elevation of a hoisting apparatus arranged and constructed in accordance with my invention.

Figure 2 is a partially sectional elevation taken on the line 2—2 of Figure 3 and showing three barrels in different stages of passage through the apparatus.

Figure 3 is an elevation of the apparatus at right angles to Figure 1 looking at the discharge end of the apparatus.

Figure 4 is another elevation looking at the apparatus from the front or intake end.

Figure 5 is a sectional detail of the same apparatus drawn to a larger scale.

Figure 6 is an enlarged sectional detail of a clutch mechanism embodied in the apparatus.

In the drawings, like parts are designated by the same reference characters throughout all the figures.

The apparatus constitutes a self-contained unitary structure of portable character and comprises a supporting structure embodying a pair of A-shaped end frames 10 and 11 which are interconnected at the rear by rods 12, 13 and 14 and by cross bars 15. The supporting structure is so arranged that the lower front thereof is free and open to permit of an unobstructed introduction of a barrel or the like at the floor level while an elevated upper portion of the rear is open to allow the discharge of the barrel at a higher level. A rotatable drum 16 is mounted in suitable bearing brackets 17 which are offset so that the drum 16 is entirely outside of the space between the A frames and consequently does not interfere with the up and down sliding motion of a vertically movable hoisting bar 18. As clearly shown in section in Figures 2 and 5 this bar is relatively thin in respect to its width and terminates at each end in blocks or projections 19 which fit into and are adapted to slide in channels 20 formed in the front sections of the respective A-frames 10 and 11. These sections may conveniently be formed of channel-irons so as to form the track or channels in which the blocks 19 run from the bottom to the top of the supporting structure. The bar 18 may be provided with rollers 19^a or other friction reducing devices at the point of contact with guides 20.

The hoisting bar 18 is connected at its respective ends to hoisting cables or chains 21 which extend upwardly in the channels 20 over sheaves or pulleys 22, on a transverse shaft 23 at the top of the frame, and downward at the front of the apparatus onto the drum 16 to which they are attached, as clearly indicated in Figure 4. The arrangement of parts is such that when the drum is turned in one direction the chains or cables are wound thereon and the hoisting rod or bar 18 is lifted, this motion being guided by the channels. The weight of the bar is sufficient to descend by gravity

and rotate the drum in the opposite direction unless it is suitably restrained.

The drum has a shaft extension 24 which is provided with a gear wheel 25 in mesh with the pinion 26 on a driving shaft 27. This driving shaft has at its opposite end a driving pulley 28 which runs idly on the shaft except when engaged by a clutch, controlled and operated by a hand lever 29, which is interposed for the purpose of connecting or disconnecting the drum to or from the pulley 28 at the will of the operator. The clutch mechanism may be of any suitable type. For example, it may comprise a cone friction clutch such as is illustrated in detail in Fig. 6 wherein the driving pulley 28 is shown as being keyed to a driving clutch member 54 which runs idly on the shaft 27. A driven friction block or cone 55 is secured to a brake wheel 56 that is pinned to the shaft 27. The hand lever 29 is arranged to operate a clutch screw 56 which may work longitudinally through a stationary nut bearing 57. By means of the lever 29 and screw 56, the clutch cone 55 may be brought into driving engagement with the clutch member 54 against the resiliency of the spring 58, and when so engaged the shaft 27 is caused to rotate. Over the brake wheel 56 is the brake band 51 that is controlled and operated by the hand lever 52 whereby regulation is obtained of the speed with which the hoisting bar 18 is allowed to descend after having been lifted.

Any suitable means may be employed for driving the machine such as the electric motor 50 having a pulley 30 which is connected by a belt 31 to the pulley 28.

In the arrangement illustrated the motor 50 and a control switch 32 are mounted on the supporting structure and a current conducting cable 33 is arranged to connect between the motor and the switch and between the switch and a terminal plug 34 which may be conveniently located near the top of the frame so that a flexible connection may be established from any suitable source such as an over-head lamp socket to the apparatus.

The barrel hoisting mechanism per se with which my invention is particularly concerned, will now be described. It consists of a pair of spaced channel guides 36 which extend in an inclined plane across the lower back corner of the frame between the cross bar 13 and a cross tie 37 which is disposed between the rod 14 and the front of the apparatus. The arrangement of the guides is clearly shown in Figures 2 and 4.

These guides 36 are adapted to receive and position a pair of flexible hoisting members or chains 38 having their upper ends secured to the cross member 13 at the top of the guides 36, and at their outer or lower ends to the movable hoisting bar 18, so as

to form a cradle or sling which is adapted to receive a barrel B, bale or other article to be hoisted. These flexible supports are spaced so as to engage a barrel, for example, not far from its ends. Of course, any number of flexible hoisting members may be used. The arrangement is such that when the hoisting bar 18 is lowered to the bottom of the channels 20 and rests upon the floor or ground, the barrel may readily be rolled over it into the cradle, it already having been pointed out that the supporting structure has its lower front portion entirely free and unobstructed for this purpose.

Assuming that the motor is in operation, it is then only necessary to manipulate the control lever 29 to throw the clutch in order to cause the drum to rotate and hoist the bar 18 which carries with it one end of the flexible hoisting cradle or sling, thus elevating the barrel and finally discharging it through the unobstructed rear portion of the structure at the level desired. A pair of ways or discharge chutes 39 are hinged to the cross bar 13, as shown in Figure 3, and may be either folded up in the position of Figure 1, or let down in a horizontal position as shown in Figure 2. In the latter position, the chutes 39 are adapted to receive and deliver the discharged barrel to the place of disposal.

During the hoisting operation, the operator stands by the machine to suitably govern its movements through the agency of the control lever 29 and the brake lever 52. As soon as the movable hoisting bar and consequently the cradle has been raised sufficiently to roll off and discharge the barrel at the desired elevation through the rear of the apparatus, the operator throws the control lever 29 to disconnect the clutch and interrupt further upward movements of the cradle. Obviously, the hoisting bar and cradle immediately descend by gravity, the hoisting cables 21 being unwound from the drum 16. The speed of descent is under the control of the operator through the brake lever 52 as will be understood.

Of course, the apparatus is equally applicable for unloading purposes when it is desired to lower barrels from one level to another. In this case, the operation is merely reversed, as will be apparent without further description.

The level of discharge is determined by the height of the cross bar 13 which may be made adjustable, so that barrels, bales or the like, may be unloaded at any desired height. Thus the rear sections of the A-frames may be provided with a number of spaced holes 53 to coincide with a hole at each end of the cross bar 13 which may be held in adjusted position by means of pins or bolts. The height of the guides 36 also may be made adjustable by constructing each of two mem-

bers of telescoping sections. Provision may be made on cross bar 13 for adjusting and holding the flexible hoisting members or chains 38 to the desired length to suit the height of cross bar 13.

The entire structure is preferably mounted on trucks or wheels 40 and 40^a. The wheels 40 are mounted on an eccentric shaft 41 in such manner as to permit of their being raised to allow the frame to set firmly on the floor or lowered to make the device portable. The shaft 41 is mounted in suitable bearings on the frame and has its ends bent to provide offset or eccentric axles 56 for the wheels 40, 40. A lever 57 for rotating the shaft 41 is secured thereto and is held in place when the wheels are in operative position by the lug 58. The wheel 40^a is carried in a yoke 61 on the lower end of the rod 59 which is slidably mounted in the brackets 60 and 60^a. A bent handle 62 having a yoke member 63 is pivoted to the yoke member 61 upon the pin 64. A bearing block 65 is loosely mounted on the rod 59 between the lower bracket 60^a and the yoke member 63. The pin 64 acts as a fulcrum so that when the handle 62 is depressed the fingers of the yoke members 63 raise the bearing block 65 and the bracket 60^a so that that side of the apparatus is raised off the floor.

In order to provide against possible injury to the apparatus in the event that the operator fails to disconnect the clutch after the barrel is discharged, a safety mechanism is provided which is adapted to automatically actuate the control lever 29 to throw out the clutch and arrest the operation of the machine. This mechanism comprises a hooked projection 44 formed at the lower end of an extensibly adjustable rod 45 that has its upper end pivotally connected to one end of an arm 46 having its other end pivotally mounted to the upper front portion of the side frame 11. The arm 46 is swingable in position about its pivoted end and its opposite end is suitably positioned by a guide frame 47 attached to side frame 10. A projecting lug 49 forms a part of the arm 46 and extends into the path of the hoisting bar 18 in such manner that as the bar approaches its upper limit of travel, it engages the lug 49 and raises the arm, which in turn elevates the hooked projection 44 of the rod 45. This projection 44 then engages and actuates the control bar 29 whereby the clutch is released to disconnect the hoisting mechanism from the source of power and thus prevent injury that might otherwise be caused.

When the apparatus is in use the electric motor is permitted to operate continuously and the attendant by means of the lever 29 actuates the clutch to raise the cradle as fast as barrels are rolled on or supplied to the hoisting cradle, using the brake lever 52 to control the lowering of the cradle.

I have found that by the use of my hoist heavy barrels can be raised steadily and easily at the rate of eight barrels a minute for an indefinite period. Furthermore, the apparatus is compact, self-contained and unitary in construction and moreover is easily portable to wherever it may be desired to be utilized. It is especially adapted for its work by reason of the fact that it is so constructed as to permit the barrels, or other loads, to be easily and quickly rolled into the machine from the front and upon the hoisting cradle and, after being elevated, to be readily and expeditiously discharged at the desired height through the rear of the machine.

Apparatus of preferred form and construction has been illustrated and described for the purpose of showing a way in which this invention may be used, but the inventive thought upon which this application is based, is broader than this illustrative embodiment thereof, and I therefore intend no limitations other than those imposed by the appended claims.

What I claim is:

1. A hoist comprising a supporting structure, a hoisting cradle affixed thereto at the height to which the load is to be elevated and means for raising and lowering the opposite end of the cradle to permit a load to be introduced at the level of the floor on which the hoist is mounted and elevated to the upper level.

2. Hoisting apparatus comprising a cradle having one end affixed at a predetermined elevation and its opposite end secured to a cross bar and movable from a point below said elevation where it is adapted to receive a load over said cross bar and raise said bar to a point materially above said elevation where it is adapted to discharge its load at said level.

3. A hoist comprising a supporting structure, a flexible hoisting cradle affixed thereto at a predetermined upper level and comprising a cross bar secured to the cradle at its opposite end and arranged so that a load may be received or discharged over said cross bar and means for raising the cross bar from a lower level to a position to enable the cradle to discharge or receive a load at the upper level.

4. A hoist comprising a supporting structure, a flexible hoisting cradle affixed thereto at one end at a predetermined upper level, a movable cross bar affixed to the cradle at its opposite end and means for raising the movable cross bar from the floor level to a position above the aforesaid upper level.

5. A hoist comprising a supporting structure, a flexible hoisting cradle affixed at one end thereto at a predetermined upper level, a movable cross bar affixed to the cradle at its opposite end, guide frames extending to

the base of said structures and engaged by the ends of the cross bar and means for actuating the cross bar throughout the length of said guide frames.

5 6. A hoist comprising a supporting structure, a flexible hoisting cradle affixed at one end thereto at a predetermined upper level, a movable cross bar affixed to the cradle at its opposite end, guide frames by
10 which the cross bar may be guided to and from the base of said frames, a hoisting drum and flexible hoisting members secured to the movable bar and arranged and off of wind onto the hoisting drum during the raising and
15 lowering of one end of the flexible cradle.

7. A hoist comprising a supporting structure embodying channel guide bars, a movable hoisting bar having end members engaging said channel bars, an upper level
20 support, a flexible cradle secured to the upper level support at one end and to the movable hoisting bar at the opposite end and a driving motor for actuating the hoisting bar.

8. A hoist comprising a supporting structure embodying channel bars, a movable
25 hoisting bar having rollers adapted to engage the channel bars, an upper level support, means for adjusting the height of said support, a flexible cradle secured to the upper
30 level support at one end and to the movable hoisting bar at the opposite end and a driving motor for raising the hoisting bar.

9. A hoist comprising a supporting structure, an upper level support, means for ad-
35 justing the height of said support, a flexible cradle affixed at one end to said support, a movable cross bar affixed to the cradle at its opposite end, guide frames engaged by the ends of the cross bar, a
40 hoisting drum and flexible hoisting members secured to the movable bar and arranged to wind on the hoisting drum to raise one end of the flexible cradle.

10. A hoist comprising a supporting structure,
45 an upper level support, a flexible cradle affixed at one end to said support, a movable cross bar affixed to the cradle at its opposite end, channels in said supporting structure adapted to guide the cross bar to the
50 base of the hoist so that a load may be introduced over said cross bar to said cradle and means for vertically actuating said cross bar and cradle.

11. A hoist comprising a supporting structure, an upper level support, means for ad-
55 justing the height of said support, a flexible cradle affixed at one end to said support, a movable cross bar affixed to the cradle at its opposite end, channels in said supporting
60 structure adapted to guide the cross bar to the base of the hoist so that a load may be introduced over said cross bar to said cradle and means for vertically actuating said cross bar and cradle.

65 12. A hoist comprising a supporting struc-

ture, an upper level support, a flexible cradle affixed at one end to said support, means attached to the other end of the flexible cradle for vertically actuating same and means for
70 guiding said flexible cradle so that it may be lowered to the base of the hoist to receive a load from the floor level and may be elevated to discharge the load over said upper level support.

13. A portable unitary hoisting apparatus
75 comprising a supporting structure having an unobstructed receiving opening at the front and near the base thereof through which the load may be rolled into place and an unobstructed discharge opening at
80 the rear and in an elevated position through which the load may be discharged, a vertically movable hoisting device disposed within said supporting structure and adapted to occupy a lowered position to receive the
85 load as it is rolled into place, and means for raising said hoisting device and load disposed thereon and discharging the load through said elevated discharge opening.

14. A portable unitary hoisting appara-
90 tus comprising a supporting structure having an unobstructed opening at the front near the bottom to permit the load to be rolled into place and another unobstructed opening at the rear, and in an elevated position
95 to permit the load to be freely discharged, a flexible hoisting cradle fixed at one end to the rear of the supporting structure at the discharge level, and means for hoisting the front end of said cradle to raise the load
100 thereon and discharge it at the desired level through the elevated discharge opening.

15. A portable unitary hoisting apparatus comprising a supporting structure having
105 an unobstructed receiving opening at the front and near the base thereof through which the load may be rolled into place, and an unobstructed discharge opening at the rear and in an elevated position through
110 which the load may be discharged, a vertically movable hoisting cradle disposed within said supporting structure and comprising at least one flexible member having its rear end attached to the supporting structure at the discharge level, a vertically mov-
115 able horizontal bar attached to the free end of said flexible member or members and adapted to occupy a lowered position to allow the load to be rolled over it into place, and means operatively connected to said
120 movable bar for raising it and the load thereon until said load is rolled out of the elevated discharge opening.

16. A portable unitary hoisting apparatus adapted to be wheeled from place to place
125 comprising a supporting structure, a plurality of wheels upon which the structure is mounted, means for raising and lowering at least some of said wheels to render the apparatus portable or rest it immovably
130

upon the floor in condition for operation, a hoisting device carried by said supporting structure and adapted to occupy a lowered position substantially at the floor level to permit the load to be rolled thereon, and controllable power-actuated means for raising said hoisting device and load thereon.

17. A hoisting apparatus comprising a supporting structure, a vertically movable cradle carried thereby and adapted to occupy a lowered position substantially in the plane of the base of said structure to permit the load to be rolled thereon, a hoisting mechanism operatively connected to said cradle, a power device carried by said supporting structure, and controllable means for connecting and disconnecting the power device to and from said hoisting mechanism.

18. A hoisting apparatus comprising a supporting structure, a vertically movable cradle carried thereby and adapted to occupy a lowered position substantially in the plane of the base of said structure to permit the load to be rolled thereon, a hoisting mechanism operatively connected to said cradle, a power device carried by said supporting structure, a driving clutch interposed between said power device and said hoisting mechanism, a brake for said hoisting mechanism, and a control lever and brake lever respectively associated with said clutch and said brake device.

19. A hoisting apparatus comprising a supporting structure, a vertically movable cradle carried thereby and adapted to occupy a lowered position substantially in the plane of the base of said structure to permit the load to be rolled thereon, a hoisting mechanism operatively connected to said cradle, a power device carried by said supporting structure, manually operable control means for connecting and disconnecting said power device to and from said hoisting mechanism, and supplemental

means for insuring the automatic operation of said control means to disconnect the hoisting mechanism from the power device when the hoisting cradle is raised to a predetermined height.

20. A hoisting apparatus comprising a supporting structure, a flexible cradle carried thereby having one end thereof fixed to said structure at an elevated position, a vertically movable hoisting bar attached to the other end of said flexible cradle and adapted to occupy a lowered position in substantially the plane of the floor to permit the load to be rolled into place, a motor operated hoisting mechanism attached to said hoisting bar for raising said bar, cradle and load thereon, and automatic means engaged and actuated by said hoisting bar when it is raised to a predetermined height for arresting the operation of said hoisting mechanism.

21. A hoisting apparatus comprising a supporting structure, a cross bar support adjustably secured to said structure in an elevated position, a flexible cradle having one end attached to said cross bar support, a vertically movable hoisting bar secured to its opposite end and adapted to occupy a lowered position in substantially the plane of the floor, an extensible channel shaped guide for said flexible cradle attached to said cross bar support, means for raising and hoisting bar and cradle, and a discharge chute pivotally secured to said cross bar support and adapted to be either folded into an inoperative vertical position or to occupy a substantially horizontal discharge position, said extensible channel shaped guide and said discharge chute being adjustable with said adjustable cross bar support.

In witness whereof I have hereunto set my hand this 28 day of Nov., 1919.

FRED C. FANTZ.