

M. J. Lourentz,

Washing Machine,

N^o 57,740.

Patented Sep. 4, 1866.

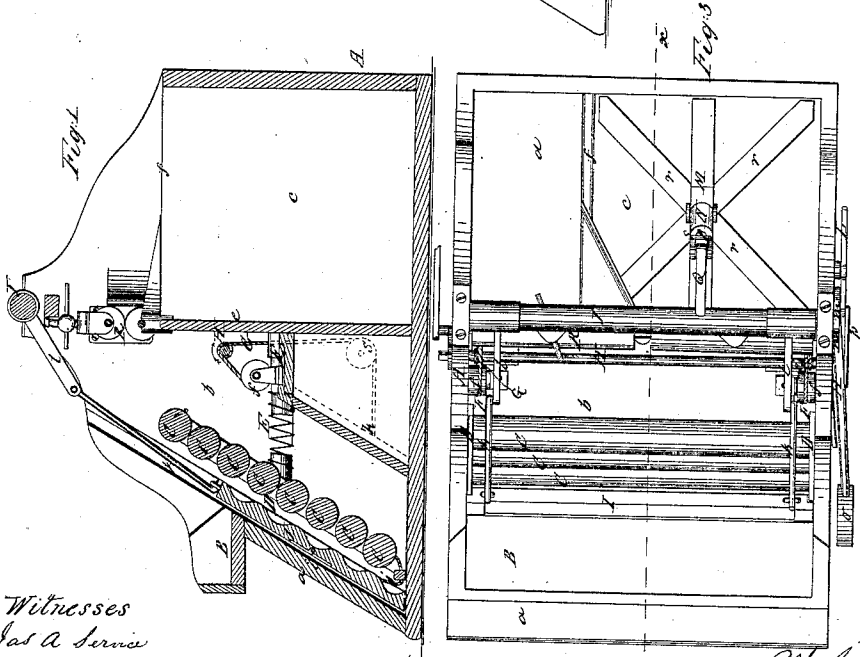
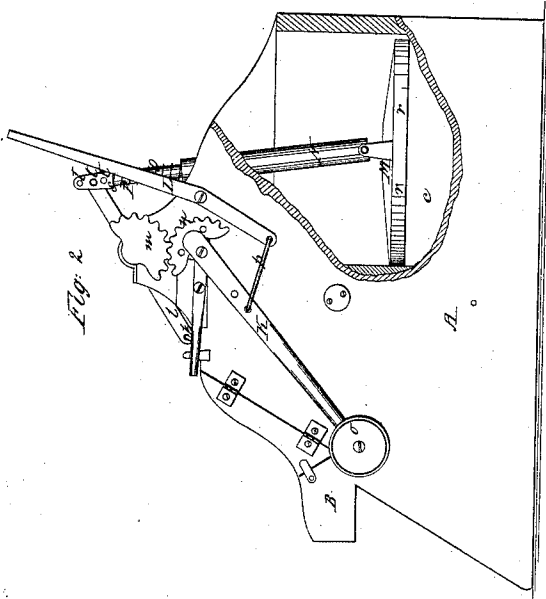

Witnesses
Jas A. Service
W. B. Huntington

Inventor
M. J. Lourentz
Per Munn & Co. Atty

UNITED STATES PATENT OFFICE.

M. J. LOURENTZ, OF LEAVENWORTH, KANSAS.

IMPROVEMENT IN WASHING-MACHINES.

Specification forming part of Letters Patent No. 57,740, dated September 4, 1866.

To all whom it may concern:

Be it known that I, M. J. LOURENTZ, of Leavenworth, in the county of Leavenworth and State of Kansas, have invented a new and Improved Clothes-Washing Machine; and I do hereby declare that the following is a full, clear, and exact description thereof, which will enable those skilled in the art to make and use the same, reference being had to the accompanying drawings, forming part of this specification, in which—

Figure 1 is a side sectional view of my invention, taken in the line *xx*, Fig. 3; Fig. 2, a side view of the same, partly in section; Fig. 3, a plan or top view of the same.

Similar letters of reference indicate corresponding parts.

This invention relates to a new and improved machine for washing clothes; and it consists in a novel construction and arrangement of parts, as hereinafter fully shown and described, whereby clothes may be thoroughly cleansed without injury, and with but a moderate expenditure of power.

A represents a case or box of quadrilateral form, the front side, *a*, of which is inclined and provided with a trough, *B*, for holding soap and clothes. This case or box is divided into three compartments, *b c d*, by vertical partitions *e f*, the front compartment, *b*, extending the whole width of the case or box and containing the rubbing mechanism of the machine. This rubbing mechanism consists of a series of rollers, *C*, placed one above the other in the same axial plane, and having their journals fitted in slides *D D*, which are connected by spiral springs *E* to slides *F*. To each of these slides *F* there is attached a cord, *G*, and these cords pass around pulleys *f* at the inner sides of the compartment *b*, and then pass around a shaft, *H*, and extend downward and pass around pulleys *g g*, and are secured to the inner sides of the compartment *b*, as shown at *h*. By turning the shaft *H* in the direction indicated by the arrow 1 the slides *F* will be moved in the direction indicated by arrow 2, and the rollers *C* adjusted forward toward a corrugated reciprocating rubber, *I*, and against the clothes between said rollers and the rubber *I* in the front part of the compartment *b*, and when the shaft *H* is turned

in the opposite direction the cords *G* will be slackened, and the springs *E* will force back the slides *F*. By this arrangement the clothes may be subjected to a greater or less pressure, as desired.

The reciprocating rubber *I* is composed of two equal parts connected by hinges *i*, and the lower end of the rubber and lower roller, *C*, are connected by cords *j* to prevent the clothes from passing underneath the lower roller and to turn the clothes as the rubber is raised and lowered. (See Fig. 1.) The upper end of the rubber *I* is connected by rods *k k*, with two arms, *l l*, attached to a rock-shaft, *J*, the bearings of which are in the upper parts of the sides of the case or box *A*. This shaft *J* has a toothed segment, *m*, at one end of it, which gears into a corresponding segment, *n*, at one end of a lever, *K*, said lever having a counterpoise, *o*, on its opposite end, and connected by a link, *p*, with a lever, *L*, by moving which back and forth the shaft *J* is rocked and the rubber *I* worked up and down, the counterpoise *o* facilitating the work. The clothes are subjected to the necessary rubbing and friction between the rubber *I* and rollers *C*. The compartment *b* is supplied with the requisite quantity of suds, and the clothes to be washed are placed between the rollers *C* and the rubber *I* by disengaging the rods *k k*, raising the rubber, and drawing its upper part over the trough *B*, the rollers *C* being drawn back by turning the shaft *H* in the proper direction. When the clothes are placed between said parts the rubber *I* is lowered, its upper end connected with the rods *k k*, the rollers *C* adjusted to give the necessary pressure to the clothes, and the rock-shaft *J* then operated.

In the compartment *c* there is fitted a pounder, *M*, constructed of cross-bars *r r*, attached to the lower end of a tubular rod, *N*, into the upper end of which a rod, *O*, passes and is allowed to slide freely, said rod *O* having a spiral spring, *P*, around it, the lower end of which bears upon the upper end of the rod *N*, and the upper end against a shoulder, *s*, at the upper end of rod *O*. The upper end of the rod *O* is connected to an arm, *Q*, on the rock-shaft *J*, so that an up-and-down motion will be given the pounder when the shaft *J* is operated. The spring *P* serves to equalize the

motion of the pounder and assists greatly the operating of it. The upper end of the rod O has several holes, *t*, made in it, so that the rod O may be adjusted higher or lower, according to the amount of clothes in the compartment *c*. This pounder M may be used for operating upon heavy clothes, such as quilts, &c., and it may also be used for rinsing clothes. The compartment *d* may be used for bluing clothing.

On the partition *e* a wringer, R, is secured for wringing the clothes. This wringer may be of the ordinary roller kind.

Having thus described my invention, I claim as new and desire to secure by Letters Patent—

1. The reciprocating rubber I, operated from

a rock-shaft, J, as shown, in combination with the pressure-rollers C, arranged with springs E, connected with adjustable bars or slides F, substantially as and for the purpose herein set forth.

2. The pounder M, connected with the rock-shaft J through the medium of the tubular rod N, sliding rod O, and spring P, substantially as and for the purpose specified.

3. The operating of the rock-shaft J through the medium of the toothed segments *m n*, counterpoised lever K, and hand-lever L, all arranged substantially as described.

M. J. LOURENTZ.

Witnesses:

C. H. CRANE,

S. B. WILLIAMS.