

(19) World Intellectual Property Organization
International Bureau



(43) International Publication Date
9 September 2011 (09.09.2011)

(10) International Publication Number
WO 2011/107573 A1

(51) International Patent Classification:
E04G 1/34 (2006.01)

(21) International Application Number:
PCT/EP2011/053250

(22) International Filing Date:
3 March 2011 (03.03.2011)

(25) Filing Language: English

(26) Publication Language: English

(30) Priority Data:
BG2010A000012 4 March 2010 (04.03.2010) IT

(72) Inventor; and

(71) Applicant : FERRARI, Alberto [IT/IT]; Via S. Antonio, 4, I-24024 Castione della Presolana (BG) (IT).

(74) Agents: GIAVARINI, Francesco et al.; Via Melchiorre Gioia, 64, I-20125 Milano (IT).

(81) Designated States (unless otherwise indicated, for every kind of national protection available): AE, AG, AL, AM, AO, AT, AU, AZ, BA, BB, BG, BH, BR, BW, BY, BZ, CA, CH, CL, CN, CO, CR, CU, CZ, DE, DK, DM, DO,

DZ, EC, EE, EG, ES, FI, GB, GD, GE, GH, GM, GT, HN, HR, HU, ID, IL, IN, IS, JP, KE, KG, KM, KN, KP, KR, KZ, LA, LC, LK, LR, LS, LT, LU, LY, MA, MD, ME, MG, MK, MN, MW, MX, MY, MZ, NA, NG, NI, NO, NZ, OM, PE, PG, PH, PL, PT, RO, RS, RU, SC, SD, SE, SG, SK, SL, SM, ST, SV, SY, TH, TJ, TM, TN, TR, TT, TZ, UA, UG, US, UZ, VC, VN, ZA, ZM, ZW.

(84) Designated States (unless otherwise indicated, for every kind of regional protection available): ARIPO (BW, GH, GM, KE, LR, LS, MW, MZ, NA, SD, SL, SZ, TZ, UG, ZM, ZW), Eurasian (AM, AZ, BY, KG, KZ, MD, RU, TJ, TM), European (AL, AT, BE, BG, CH, CY, CZ, DE, DK, EE, ES, FI, FR, GB, GR, HR, HU, IE, IS, IT, LT, LU, LV, MC, MK, MT, NL, NO, PL, PT, RO, RS, SE, SI, SK, SM, TR), OAPI (BF, BJ, CF, CG, CI, CM, GA, GN, GQ, GW, ML, MR, NE, SN, TD, TG).

Declarations under Rule 4.17:

— of inventorship (Rule 4.17(iv))

Published:

— with international search report (Art. 21(3))

[Continued on next page]

(54) Title: MODULAR STRUCTURE FOR SCAFFOLDING

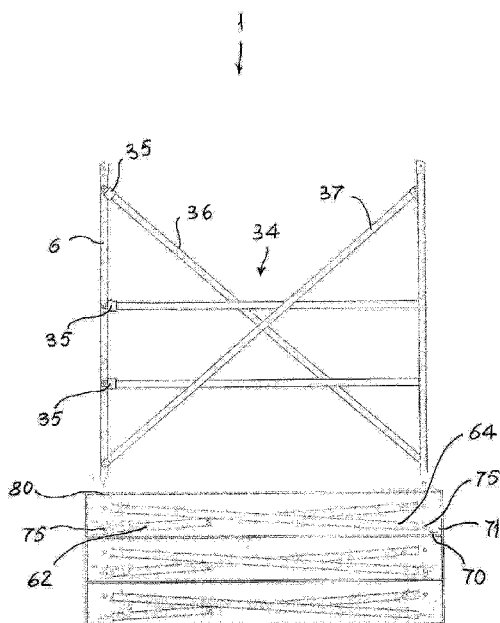

FIG. 1

(57) Abstract: A modular scaffolding structure comprising a plurality of collapsible parallel quadrangular platforms inter-connected by a plurality of struts comprising a first, lower end provided with first means of mobile coupling with a first corresponding platform, and a second, upper end provided with second means of mobile coupling with a second corresponding platform positioned adjointly above said first platform. The first means of mobile coupling allow the rotation of said struts around a hinge point and the second means of mobile coupling allow said second end of said struts to slide with respect to said second corresponding platform. The struts are movable between a first position in which they lie interposed between said first and second platform, and a second position in which they extend substantially perpendicular to said platforms. The structure also comprises first and second blocking means for blocking said first and second means of mobile coupling.

WO 2011/107573 A1

- *before the expiration of the time limit for amending the claims and to be republished in the event of receipt of amendments (Rule 48.2(h))*

MODULAR STRUCTURE FOR SCAFFOLDINGDESCRIPTION

The present invention relates to a modular scaffolding structure, particularly a modular scaffolding structure of a collapsible type.

Scaffolding types are known, for example for building or similar uses, constituted of a plurality of vertical struts, connected by transverse elements, forming the load-bearing structure of the scaffolding. On this load-bearing structure are then placed platforms for walking, as well as safety barriers for workers and/or to prevent the fall of materials.

The scaffolding assembly procedure is usually a complex and relatively long activity, requiring the use of a relatively large number of operators for relatively long periods of time.

It is also known that a minimum of three operators are required to assemble/disassemble the scaffolding and that they must have specific skills and requisites according to national safety standards.

Indeed, in certain countries, such as Italy for example, these operators must have completed a specific training course to be able to work in the sector and to be able to issue to the client the safety documentation relating to the scaffolding. In Italy, under current legislation, this document consists of the so-called P.I.M.U.S. (Scaffolding assembly, disassembly and maintenance plan).

For this reason, in recent years scaffolding are assembled and disassembled by firms specialising only in the assembly and disassembly of scaffolding.

In general, assembly and disassembly procedures are therefore complex and costly since they require the use of qualified, specialised labour for relatively long periods of time.

It would therefore be useful to have scaffolding that could be assembled in the shortest possible time with less use of specialist operators.

The aim of this invention is to provide a scaffolding structure that overcomes the problems described above.

The present invention therefore relates to a modular scaffolding structure, characterised in that it comprises a plurality of collapsible parallel quadrangular platforms inter-connected by a plurality of corresponding struts, said struts comprising a first, lower end provided with first means of mobile coupling with a first corresponding platform, and a second, upper end provided with second means of mobile coupling with a second corresponding platform positioned adjointly above said first platform, said first means of mobile coupling allowing the rotation of said struts around a hinge point and second means of mobile coupling allowing said second end of said struts to slide with respect to said second corresponding platform, said

struts being movable between a first position in which they lie parallel to said first and second platform and a second position in which they extend substantially perpendicular to said first and second platform, said structure also comprising first blocking means for blocking said first means of mobile coupling, and second blocking means for blocking said second means of mobile coupling.

In practice, the modular structure according to the invention is constituted of collapsible units that can be opened and closed, facilitating both transport and raising on site.

In this manner, the modular scaffolding structure can be pre-assembled in the warehouse, in complete safety, based on the client's needs. As described in more detail below, once the modular structure has been pre-assembled, it can be transported in its closed form to the site where it is to be used, and then raised extremely easily using a limited number of operators.

The modular structures according to the invention are then coupled together and anchored to the building, thereby enabling a scaffolding to be obtained extremely quickly and safely, using a limited number of operators.

Preferably, said first blocking means are operable by said second means of mobile coupling and said second blocking means are operable by said first means of mobile coupling.

According to a preferred embodiment of the invention, said first means of mobile coupling comprise means of hinging said struts with respect to said first platform and said second means of mobile coupling comprise pulley means operationally connected to said second platform and to said second end of said struts.

Normally, said platforms are substantially rectangular; other forms (square for example) are possible however.

Advantageously, the modular scaffolding structure according to the invention may comprise first means of protection connected to said struts and/or to said platforms.

For example, said first means of protection may comprise belt means and means for the self-winding of said belt means connected to said struts and/or to said platforms.

Moreover, preferably, the modular scaffolding structure according to the invention may comprise second means of protection connected to said struts and/or to said platforms.

Said second means of protection, may for example comprise sheeting means and means for the self-winding of said sheeting means connected to said struts and/or to said platforms.

Preferably, said platforms have pass-through openings.

A preferred embodiment of the modular scaffolding structure according to the invention, includes means of lateral coupling with corresponding modular structures, to create a complete scaffolding structure.

A scaffolding comprising a plurality of modular structures as described, also constitutes an aspect of this invention.

These and other features of the present invention will become more apparent from the following detailed description of an embodiment of a modular scaffolding structure according to the invention, which is illustrated by no way of limitation in the accompanying drawings, in which:

- figure 1 shows a cross-section view of an embodiment of a modular scaffolding structure according to the invention;
- figures 2a, 2b, 2c, show a cross-section view of an opening sequence for a modular scaffolding structure according to the invention;
- figure 3 shows a plan view of a detail of a modular scaffolding structure according to the invention;
- figures 4a, 4b, show a view of several embodiments of struts that can be used in a modular scaffolding structure according to the invention;
- figures 5a, 5b, 5c, 5d, 5e show details of an opening sequence for a modular scaffolding structure according to the invention;
- figures 6a, 6b, 6c shows details of a closure sequence for a modular scaffolding structure according to the invention;
- figure 7 shows a side view of an embodiment of a modular scaffolding structure according to the invention;
- figures 8a, 8b show respectively a side view and a front view of the modular structure illustrated in figure 7.

With reference to figures 1-4, a modular scaffolding structure, as a whole designated with reference number 1, comprising of collapsible parallel quadrangular platforms 2,3,4,5,70,80 that are inter-connected by a plurality of corresponding struts 6,61,62,63,64.

The struts 6,61,62,63,64 comprise a first, lower end 7, which is provided with first means of mobile coupling 71 with a first corresponding platform 70, and a second, upper end 8, provided with second means of mobile coupling 81 with a second corresponding platform 80 positioned adjoiningly above said first platform 70.

The structure 1 according to the invention is therefore in practice constituted by a plurality of collapsible overlying platforms connected by struts so that the top part of each platform is connected to the bottom end 7 of the struts above and the bottom part of each platform is connected to the top end 8 of the struts below. For the purposes of this invention, the terms above and below refer to the modular scaffolding structure in its normal operating position,

such as that illustrated in the accompanying drawings.

One of the peculiar features of the modular structure 1 according to the invention, is the fact that said first means of mobile coupling 71 allow the rotation of said struts 6,61,62,63,64 around a hinge point 75 and second means of mobile coupling 81 allow said second end 8 of said struts 6,61,62,63,64 to slide with respect to said second corresponding platform 80.

The struts 6,61,62,63,64 are therefore able to move between a first position in which they lie interposed between said first 70 and second platform 80 and a second position in which they extend substantially perpendicular to said first 70 and second platform 80.

Lastly, the structure 1 according to the invention also comprises first blocking means 40 for blocking said first means of mobile coupling 71 and second blocking means 50 for blocking said second means of mobile coupling 81.

In practice, with reference to figure 1, the structure 1 according to the invention, in its folded form, is substantially constituted of a compact, packed system of platforms and struts that can be pre-assembled far from the site of installation. The number of platforms that can be connected together depends on the client's needs (i.e. the total height of the scaffolding).

The structure is then transported in its folded form to the site where it is to be used and positioned at the points of use.

With reference to figures 2a, 2b, 2c, the structure is opened very simply by connecting the top end of the structure 1 to lifting means, for example a crane.

As a result of the traction exerted by the crane, the structure 1 opens progressively, floor after floor, beginning with the base element, thanks to the combined action of the rotation of the bottom end 7 of the struts around the hinge point 75 and the sliding of the top part 8 of the platforms with respect to the platform above them. As described in more detail below, the simultaneous opening of all the platforms is prevented by the presence of the first blocking means 40 that block the first means of mobile coupling 71 and the second blocking means 50 that block the second means of mobile coupling.

Preferably, said first blocking means 40 are operable by said second means of mobile coupling 81 and said second blocking means 50 are operable by said first means of mobile coupling 71.

In this manner the blocking and unblocking in succession of the platforms begins only after one platform has been completely opened.

A particularly preferred embodiment of the modular scaffolding structure 1 according to the invention, has it that the first means of mobile coupling 71 comprise means of hinging said struts 6,61,62,63,64 with respect to said first platform 70, while the second means of mobile

coupling 81 comprise pulley means operationally connected to said second platform 80 and to said second end 8 of said struts 6,61,62,63,64.

In practice, with reference to figure 2a, during opening of a given level (for example the second level as shown in figure 2a) the presence of the first and second blocking means prevents the simultaneous opening of the other levels. Once opening of the second level has been completed (figure 2b), the pulley means fixed to the top of the second level struts act, as explained in more detail below, on the first blocking means of the hinging means of the third level struts, by unblocking the rotation of said struts and allowing the opening of the third level (figure 2c).

As illustrated in figure 3, said platforms 2,3,4,5,70,80 are preferably rectangular in shape.

Moreover, preferably, the modular scaffolding structure 1 according to the invention, comprises means of lateral coupling with corresponding modular structures.

For example, these means of lateral coupling may consist of attachment elements positioned at the level of the platforms or walking surfaces with male/female shaped ends 101 for coupling with the adjoining surfaces.

For example, U-shaped elements may be positioned on the top part of the platforms, for example four U-shaped elements positioned on the short sides of the platforms, used for fastening the bottom part of the struts. These U-shaped elements may be fixed (welded) or fixed in place subsequently using flat-head screws. In this case, the positioning of the elements must not create any obstacle to the sliding elements positioned under the platform.

Advantageously, the platforms also have on top a fixed longitudinal foot guard 102, on the outside (i.e. on the side opposite the building) and possibly also a portion of foot guard on the inside (building side). Contextually, the foot guard may also have a continuation below the platform, forming "louvres" 103 that extend downwards.

The foot guard/louvre assembly has several functions.

For example, it can be used when closing to form the "packages" of the modular structure 1 when it is folded. In fact, when the scaffolding is closed, these louvres rest on top of one another forming the package that protects all the elements inside and above all prevents the crushing of the internal elements.

Moreover, the foot guard helps prevent the fall of materials from the walking surface.

The foot guard/louvre assembly may also be provided with holes for the passage of a strap (fastened to a crane, mobile crane, winch, etc.) for raising and lowering the scaffolding during the assembly/disassembly phase, and to facilitate the loading/unloading of the package, and may also be provided with hooks for fastening means of protection.

A further function of the foot guard/louvre assembly is that of protecting from dirt (plaster, cement, paint, etc.) the guides and the sliding element (pulley).

As far as the head section platforms are concerned (first and last), they may also have a foot guard fixed to the external short side; alternatively, the platforms may be all the same, providing however for the addition of a foot guard at the head section (similar to traditional scaffolding).

Preferably, the central part of the walking surface may be made of a non-slip, grained material (similar to current systems) that, among other things, also enables a reduction in weight. At the strut attachment and sliding points, it is possible to provide reinforcements of different material and/or thickness, so as to support the sliding of the pulleys and support the loading and thrust forces at the hinges.

On the bottom of the platform, guides are usually positioned for the struts to slide along. These guides may be of any shape, since in substance they only need to act as rails.

The guides may be fixed to the platform using flat-head screws, welded or recessed into the platform. They may be single-piece bars or pieces that slot into one another.

In the embodiment illustrated, the pulleys operationally coupling to the top of the struts are hooked to the guides placed under the platform. For correct maintenance or for their replacement, the pulleys can be assembled/disassembled even when the scaffolding is raised, for example by using props that temporarily replace the strut.

Preferably, the pulleys can be self-lubricated and self-cleaning, i.e. they can have a lubricant inside them that lubricates the guide with each movement, as well as brushes that help to keep said guide clean.

With reference to figures 4a, 4b, the struts can be different according to the height and the use of the scaffolding.

For example, with reference to figure 4b, a first type of strut comprises two "legs" 63, 64 connected to one another by means of a cross member 66 placed at the top 8. This cross member 66 enables the weights and forces on the scaffolding to be discharged homogeneously. A second type of strut, illustrated in figure 4a, consists of a pair of legs 61 and 62 that are the same and not joined together.

In practice, also with reference to figure 3, the strut illustrated in figure 4b is hinged to the short side of a platform 2, with legs 63 and 64 positioned inside legs 61 and 62, which in turn are hinged to the opposing short side of the platform. In this manner, the upward opening and sliding of the legs 61, 62, 63 and 64 are not hindered and mutually impeded.

Moreover, as with traditional scaffolding, it is possible to have a ladder column, in which case

the platforms will have pass-through openings and hooks or catches for positioning ladders. Obviously, the platforms with the openings can be for a full column or can be spread over various columns.

Should the module include pass-through openings in platforms with respective ascending and descending ladders, the struts will preferably be of the type illustrated in figure 4a, since the ladders will be fixed to the platforms, thereby constituting an interference for the cross member 66 of the strut illustrated in figure 4b.

The struts can be of any form (tubular, square, rhomboidal, etc.). At the top 8 and bottom 7 they advantageously have narrowing structures, forming "plates" for connection with the first 71 and second 81 means of mobile coupling.

Advantageously, at the bottom of the strut it is possible to provide catches, for example welded elements 95 on the strut that, when the strut is vertical, can act on the blocking means preventing any involuntary operation of said means with the consequent activation of the disassembly procedure.

Moreover, the struts on the bottom platform can be height adjusted (as with current scaffolding) so as to ensure the perfect horizontal positioning of the structure, regardless of the conformation of the supporting surface.

As mentioned above, preferably the first means of mobile coupling 71 comprise means of hinging said struts with respect to said first (bottom) platform 70 and said second means of mobile coupling 81 comprise pulley means operationally connected to said second (top) platform 80 and to the second end 8 of said struts 6,61,62,63,64.

In practice, in the embodiment illustrated, the means of hinging may comprise the U-shaped elements fixed to the platform 2, and to these U-shaped elements the bottom part 7 of a strut 6 is hinged. This hinge thus serves for fastening of the strut by means of a horizontal pin 75 and also for positioning the blocking/unblocking system. Moreover, these hinges advantageously have a raised rear part 98 that acts as a further catch for the strut 6 when it is in a vertical position.

In the embodiment illustrated, the hinge has a hole for the passage of a vertical blocking pin 50.

Note that, when the struts are in a vertical position (when the scaffolding is assembled), they rest on the base of the hinge, which in turn rests on the platform. In this manner, a strut discharges the forces and weights onto the corresponding strut below, and so on, until these forces and weights are completely discharged to the ground.

In the embodiment illustrated, the horizontal pins 75 serve to fix the struts 6 to the hinge, but

above all to move the blocking and unblocking elements, comprising at least one washer 69 and one lever 93 respectively. The horizontal pins 75 are threaded at the ends for engaging with a closure nut, while the central part has different sections for engaging with the blocking and unblocking elements.

The blocking elements preferably comprise a pair of blocking washers 69 (appropriately shaped to interact with the catches) that are mounted fixed to the right and left of the horizontal pin 75 and have the function of blocking the struts during closure and keeping the upper struts blocked in position when opening.

In practice, the washers 69 are “fixed” onto the horizontal pin and therefore have no type of “play”, and act as a block for the blocking system (as illustrated in more detail below), by holding the struts closed.

The unblocking elements comprise a pair of blocking levers 93 that are mounted to the right and left of the horizontal pin 75.

These levers 93, as illustrated in more detail below, act only during the closure phase, and serve to unblock the lower level of the modular scaffolding structure. In practice, as illustrated in more detail below, when the lever 93 raises the vertical blocking pin 50, the upper level of the modular scaffolding structure is blocked by the washer 69 and, immediately after the upper level is blocked, the lower level is unblocked because the lever 93 has fully raised the vertical blocking pin 50 that was blocking the second means of mobile coupling 81 (the pulley means in the case illustrated) on the level below.

The pulley means comprise, at the bottom of the pulley, a U-shaped element, similar to the U-shaped elements present on the platform 2, which enables coupling with the top part 8 of a strut 6. The top part of the pulley is coupled with a sliding guide integral with the bottom part of a platform 2.

Inside the pulley there are holes for housing the vertical blocking pins 50. As explained in more detail below, on opening the modular structure 1, the pulleys compress at least one seal rubber seal 91 that, normally, holds in a raised position a corresponding vertical blocking pin 50. As a result of the compression exerted by the pulley, the rubber seal 91 retracts, thereby allowing said vertical pin 50 to descend into a corresponding hole in the pulley, blocking it in position.

With reference to figures 5a-5e, the operation of the first 40 and second 50 blocking means during opening of a modular structure 1 according to the invention is now illustrated.

When the structure 1 is in a closed and packed position, the vertical blocking pins 50 are supported at a certain height by catches or rubber seals 91, which are present on the bottom

louvres of the platform 2, and are held in this position during the raising and opening of said structure (figure 5a). When the pulley (or the sliding element in general) reaches the final position (figure 2), the rubber seals 91 are compressed against the pulley allowing the vertical pins 50 to enter the pulley stop holes, thereby blocking the lower level (which is at this stage in a totally raised and opened position). The vertical pins 50 advantageously have a horizontal arm 15 that, following lowering of the pin 50, acts on a pressure-operated unblocking system 40 (figure 5c) which in turn makes the catches that were blocking the blocking washers 69 of the upper strut move backwards, thereby enabling the unblocking of the upper strut. The unblocked upper strut is raised (figure 5d) and the unblocking lever 93 passes through a dovetail opening in the horizontal arm 15 of the vertical pin 50 (allowing only the descent of the lever 93 and preventing it from rising), until it reaches the final position illustrated in figure 5e. In this position, the catches 95 on the strut act on the vertical pin 50 preventing any involuntary raising of the pin with the consequent activation of the disassembly procedure.

With reference to figures 6a-6c the typical operation of the first 40 and second 50 blocking means during closure of a modular structure 1 according to the invention is now illustrated.

With reference to figure 6a, closure operations begin from the top. When the struts begin to fold down, the lever 93 is raised at the same time, since it is integral with the horizontal pin 75. In this movement, the lever 93 acts on the horizontal arm 15 of the vertical pin 50 causing it to rise gradually.

The progressive folding of the upper strut and the consequent progressive raising of the vertical pin 50 enables the corresponding raising of the pressure-operated unblocking system 40 (figure 6b). In this manner, when the upper struts are fully folded (figure 6c), the pressure-operated unblocking system 40 returns to the blocking position of the blocking washer 69 that, in turn, prevents all opening movement of the upper strut. Moreover, when the upper strut is blocked, the pulley below is uncoupled, since the vertical pin 50 is completely raised and disengaged from the corresponding hole in said pulley. When the pulley moves, the rubber seals 91 return to their original non-compressed position, thereby blocking the vertical pin 50 in the raised position.

In the example described, this system of operation is substantially similar for all levels. Only for the last (highest) level can it be different. In this level, the struts can conveniently be mounted in a fixed position, i.e. without the presence of the pressure-operated unblocking system. In this case, the vertical pins 50 are also fitted with rings or hooks, used for the passage of a cord or similar traction system, which when activated raises the vertical pins 50 of the last level, thereby initiating the unblocking procedure and the folding of the entire

modular structure 1. For safety reasons, when the cord is pulled, the modular structure 1 is conveniently tied to a crane (or any device, winch, mobile crane or similar) by means of safety harnesses.

Preferably, the modular scaffolding structure 1 according to the invention comprises first means of protection 34 connected to said struts 6,61,62,63,64 and/or to said platforms 2,3,4,5,70,80.

Advantageously, said first means of protection 34 comprise belt means 36,37,38,39 and means for the self-winding 35 of said belt means 36,37,38,39 connected to said struts 6,61,62,63,64 and/or to said platforms 2,3,4,5,70,80.

These belt means (for example harnesses) can be of various types, possibly both horizontal 38, 39, and diagonal, 36, 37, and possibly positioned both on the long external side and on the short external side of the structure 1. Moreover, the presence is possible of adjustable belt means (i.e. fitted with an adjustment system) in the case of staggered scaffolding structures, for example when going around the corner of a building, the scaffolding head sections do not meet.

Note that the belt means 36, 37 on the long side, in addition to forming a safety parapet, also serve, during the disassembly phase, to apply the initial closing thrust to the struts.

The presence of self-winding means 35 means that there are never slack sections when the structure is folding, thus avoiding any obstruction.

Moreover, preferably said belt means are self-cleaning and have catches or brushes or similar devices to eliminate any fouling.

It is also possible to have harnesses that tie various adjacent structures together, these harnesses being mounted only when the various modular structures constituting the scaffolding have been erected. It is preferable, however, to have means of lateral coupling between two adjacent structures 1 of the type described above.

In order to allow the attachment of said belt means, the struts may conveniently have threaded bars placed at different heights. These bars serve for attaching the diagonal and horizontal safety belt means. The bars are preferably present on all struts, even those on the building side, to enable the possible use of belt means on all four sides of the structure 1.

With reference to figures 7, 8a, 8b, the modular scaffolding structure 1 according to the invention, may also preferably comprise second means of protection 54 connected to said struts 6,61,62,63,64 and/or to said platforms 2,3,4,5,70,80.

Said second means of protection 54 comprise for example sheeting means 56 and means for the self-winding 55 of said sheeting means 56 connected to said struts 6,61,62,63,64 and/or to

said platforms 2,3,4,5,70,80.

As can be seen from figures 7, 8a, 8b, said sheeting means 56 are advantageously positioned below the walking surface at the height of a platform 2. When the modular structure 1 is closed, the roll of sheet means 56, which are preferably of a self-winding and self-cleaning type, is protected by the louvre 103 descending from the platform above.

The sheeting means 56 are fixed to the platform below, for example by fastening them to hooks presents on the inside of the foot guard 102.

When the modular structure 1 opens upwards, the sheeting means 56 also open automatically, while the means for the self-winding 55 of said sheeting means 56 allow the immediate winding of said sheeting means 56 during the structure 1 closure phase, thereby preventing the creation of obstacles or impediments. This element may also be replaced or adjusted when the scaffolding is raised.

As can be seen from the previous description, the technical solutions adopted for the modular scaffolding structure according to the invention enable it to fully achieve the pre-set tasks and objects.

First of all, the modular structure according to the invention makes it possible to create scaffolding structures in which there is a drastically reduced risk of falling from a height, since the presence is no longer required of operators who assemble the scaffolding piece by piece at hazardous heights, even if they are secured with safety harnesses.

Moreover, assembly and disassembly of the scaffolding is much faster, thus reducing considerably the presence of specialised labour during installation, with a consequent significant reduction in costs.

Another aspect to underline is the fact that the structure according to the invention can be adapted to extremely diverse situations in terms of the heights to be reached, since the structure can easily be adapted according to height and use, simply by removing or adding platforms and relative struts during the pre-assembly phase.

In the case of extremely tall buildings, which would render problematic the transport of the modular structure in a single packed unit, both for its dimensions and its weight, the scaffolding can in any case be constructed by adding successive packages to the scaffolding structure as required, and thus erecting it using successive modules.

Moreover, the modular structure according to the invention can also be easily adapted to situations in which the scaffolding, instead of resting on the ground, is anchored at a height. Once the package is anchored at a height, it can be opened downwards using the opposite procedure from that used for raising from the ground.

As mentioned above, the raising (or downward lowering) of the modular structure according to the invention can be conveniently carried out with the help of a crane, mobile crane or similar. It is possible, however, to have the structure fitted with autonomous means of movement (for example electric motors suitably connected to the various platforms or telescopic raising systems) which would allow the opening and closure of the scaffolding automatically.

The modular structure thus conceived is extremely reliable because the pre-assembly phase can be conducted calmly, verifying always the state of wear of the components and the materials. The modular structure also has a simple, extremely compact and easy-to-build configuration, which advantageously makes it possible to keep down manufacturing and assembly costs.

In practice, the materials used and dimensions and contingent forms can be any according to requirements and to the state of the art.

CLAIMS

1. A modular scaffolding structure (1) characterised in that it comprises a plurality of collapsible parallel quadrangular platforms (2,3,4,5,70,80) inter-connected by a plurality of corresponding struts (6,61,62,63,64), said struts (6,61,62,63,64) comprising a first, lower end (7) provided with first means of mobile coupling (71) with a first corresponding platform (70), and a second, upper end (8) provided with second means of mobile coupling (81) with a second corresponding platform (80) positioned adjointly above said first platform (70), said first means of mobile coupling (71) allowing the rotation of said struts (6,61,62,63,64) around a hinge point (75) and second means of mobile coupling (81) allowing said second end (8) of said struts (6,61,62,63,64) to slide with respect to said second corresponding platform (80), said struts (6,61,62,63,64) being able to move between a first position in which they lie interposed between said first (70) and second platform (80) and a second position in which they extend substantially perpendicular to said first (70) and second platform (80), said structure (1) also comprising first blocking means (40) for blocking said first means of mobile coupling (71), and second blocking means (50) for blocking said second means of mobile coupling (81).
2. A modular scaffolding structure (1) according to claim 1, characterised in that said first blocking means (40) are operable by said second means of mobile coupling (81) and said second blocking means (50) are operable by said first means of mobile coupling (71).
3. A modular scaffolding structure (1) according to claim 1 or 2, characterised in that said first means of mobile coupling (71) comprise means of hinging said struts (6,61,62,63,64) with respect to said first platform (70) and said second means of mobile coupling (81) comprise pulley means operationally connected to said second platform (80) and to said second end (8) of said struts (6,61,62,63,64).
4. A modular scaffolding structure (1) according to one or more of the previous claims, characterised in that said platforms (2,3,4,5,70,80) are substantially rectangular.
5. A modular scaffolding structure (1) according to one or more of the previous claims, characterised in that it comprises first means of protection (34) connected to said struts (6,61,62,63,64) and/or to said platforms (2,3,4,5,70,80).
6. A modular scaffolding structure (1) according to claim 5, characterised in that said first means of protection (34) comprise belt means (36,37,38,39) and means for the self-winding (35) of said belt means (36,37,38,39) connected to said struts

- (6,61,62,63,64) and/or to said platforms (2,3,4,5,70,80).
7. A modular scaffolding structure (1) according to one or more of the previous claims, characterised in that it comprises second means of protection (54) connected to said struts (6,61,62,63,64) and/or to said platforms (2,3,4,5,70,80).
 8. A modular scaffolding structure (1) according to claim 7, characterised in that said second means of protection (54) comprise sheeting means (56) and means for the self-winding (55) of said sheeting means (56) connected to said struts (6,61,62,63,64) and/or to said platforms (2,3,4,5,70,80).
 9. A modular scaffolding structure (1) according to one or more of the previous claims, characterised in that said platforms (2,3,4,5,70,80) have pass-through openings.
 10. A modular scaffolding structure (1) according to one or more of the previous claims, characterised in that it comprises means of lateral coupling with corresponding modular structures.
 11. Scaffolding comprising a plurality of modular structures (1) according to one or more of the previous claims.

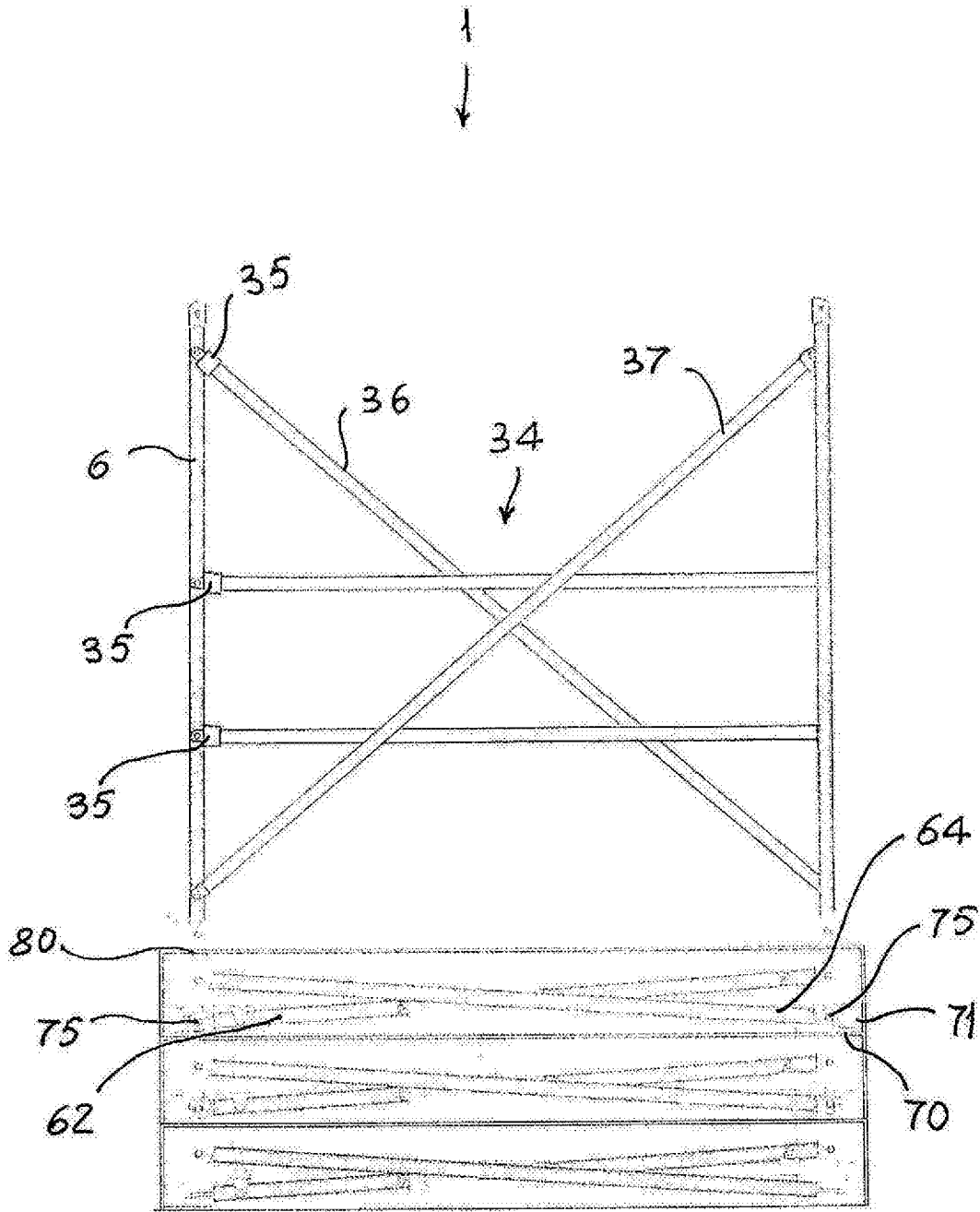
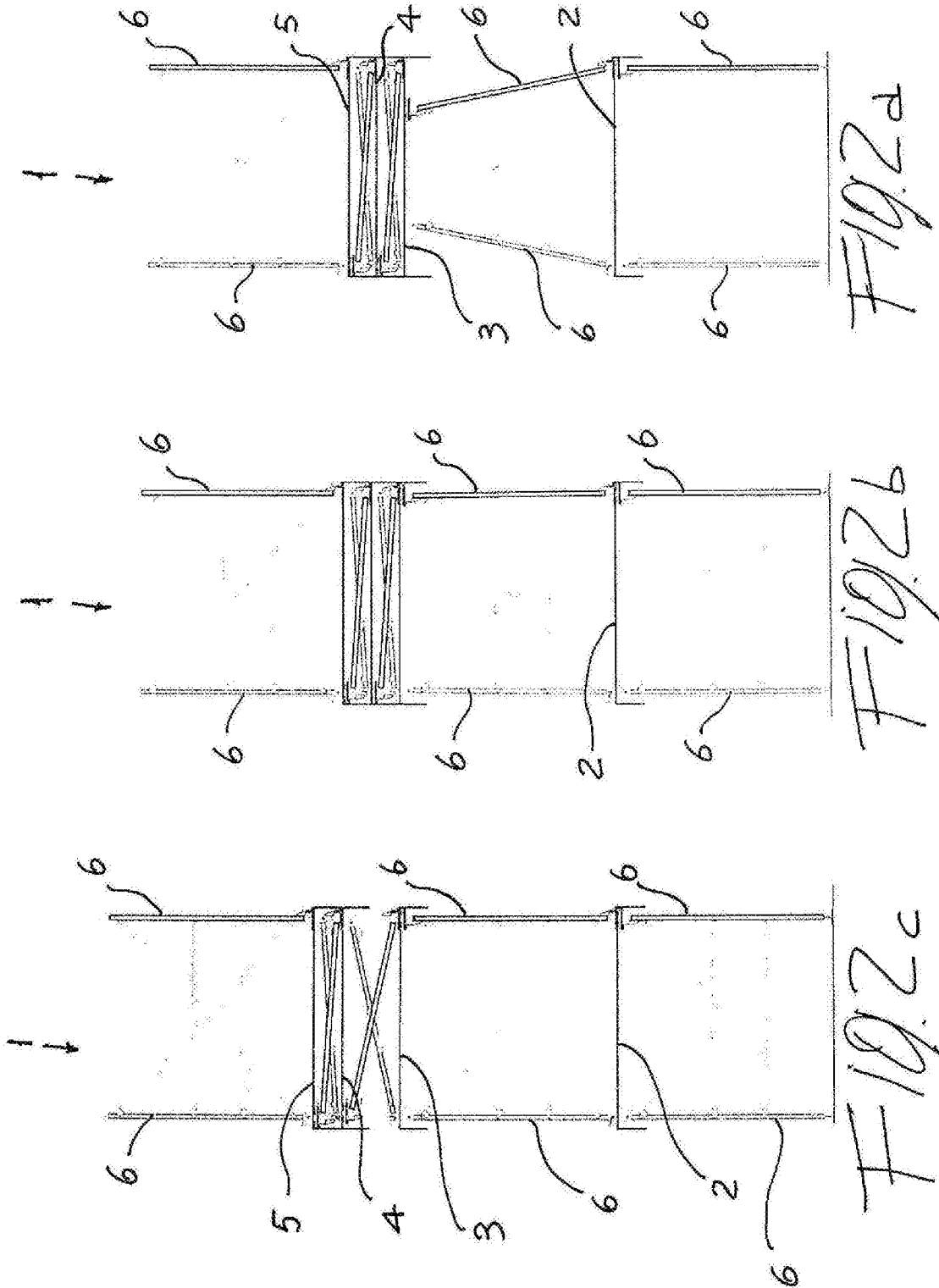

Fig. 1



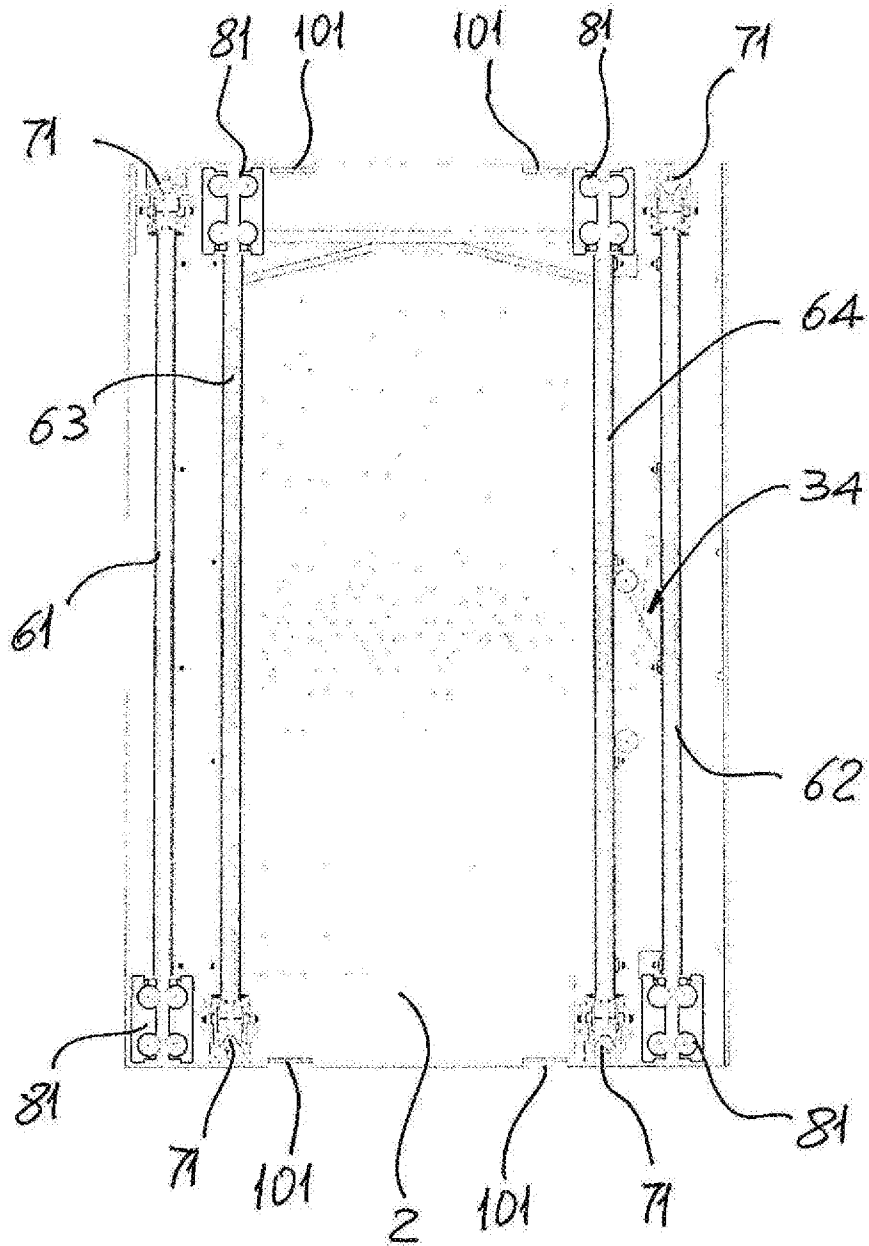

FIG. 3

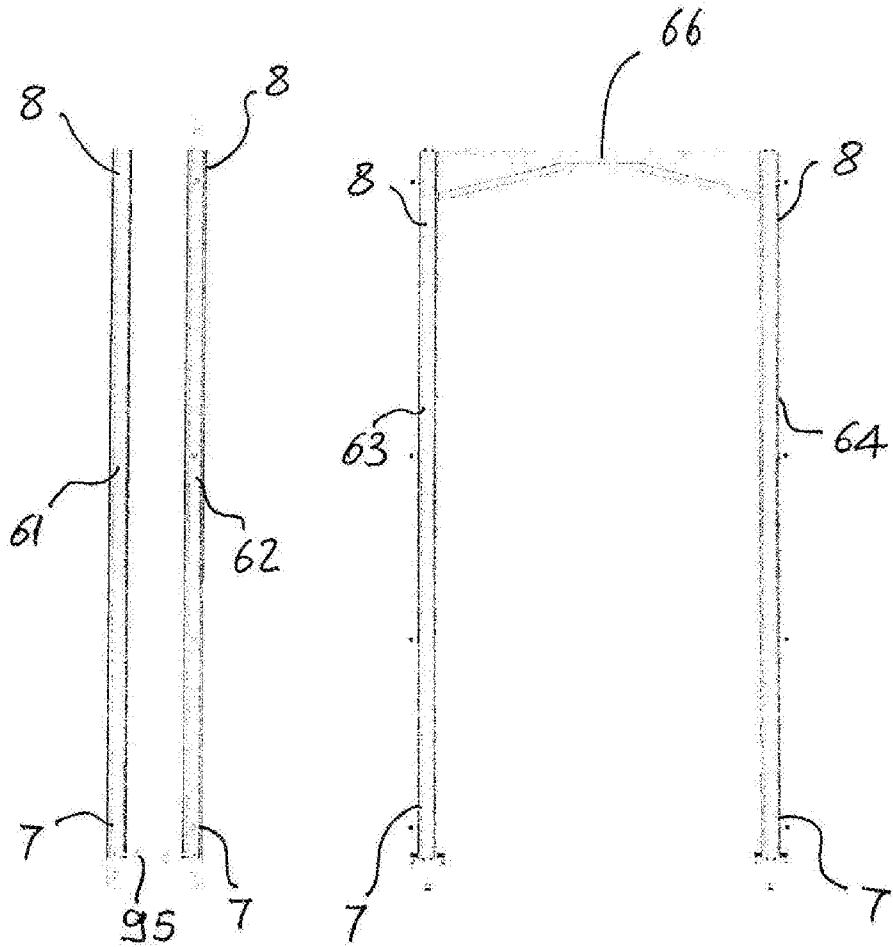

FIG. 4d

FIG. 4b

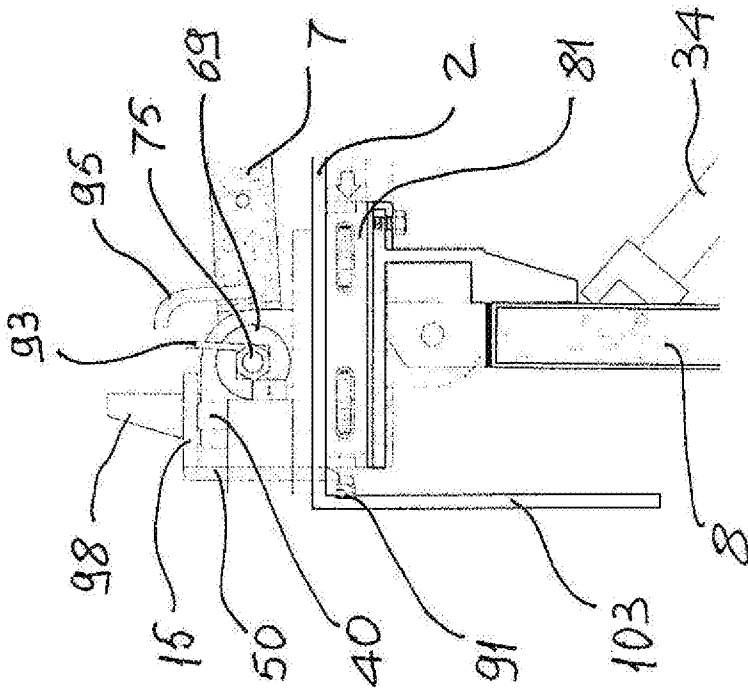

Fig. 10.5a

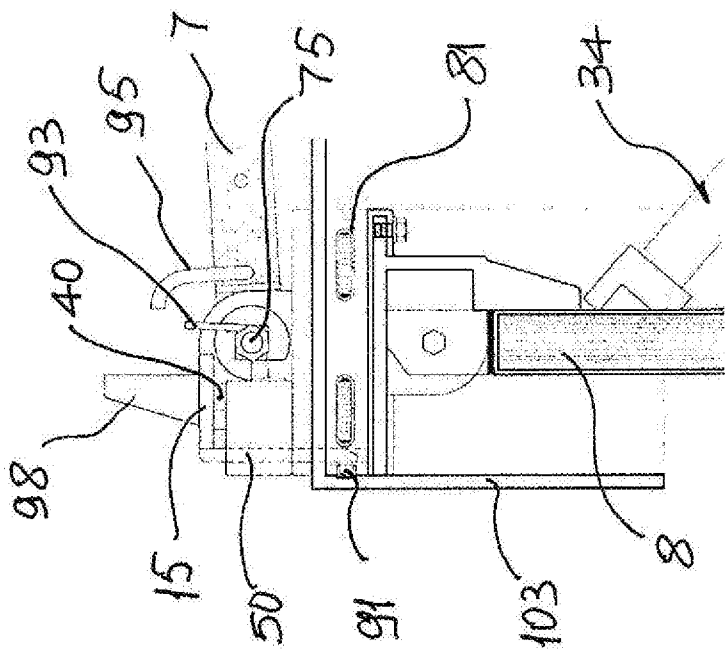

Fig. 10.5b

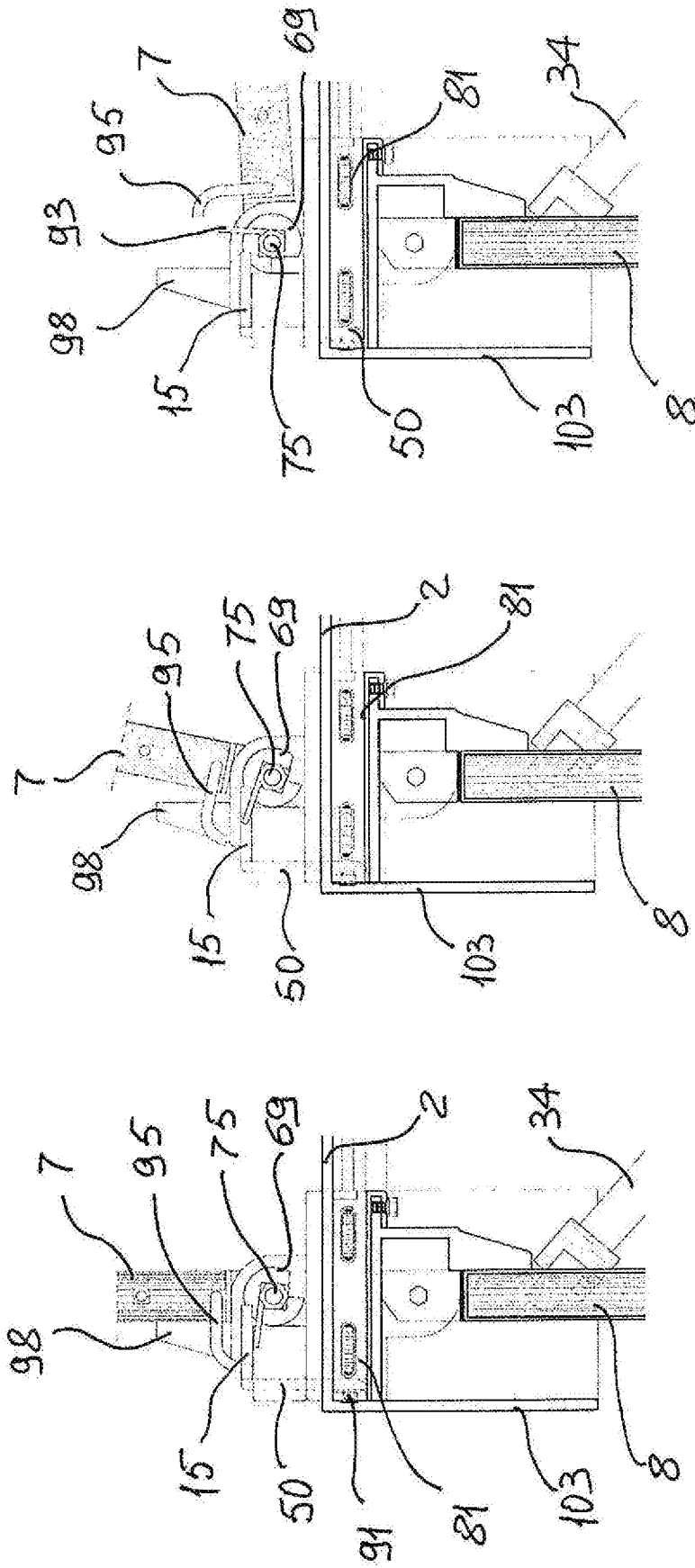

Fig. 5c

Fig. 5d

Fig. 5e

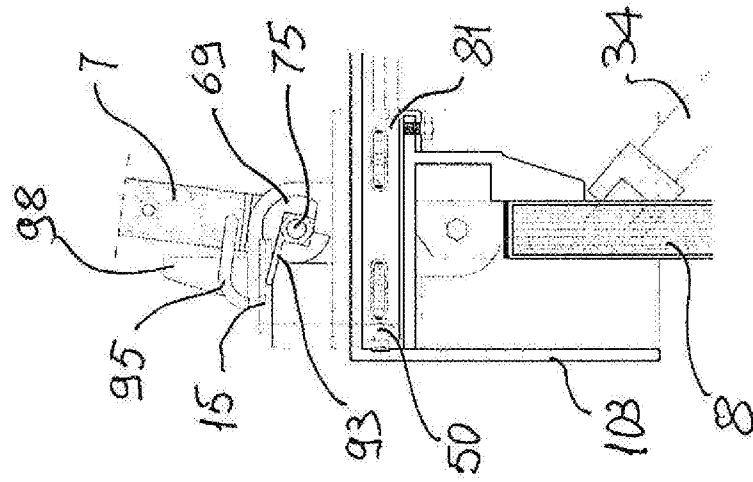

Fig. 6a

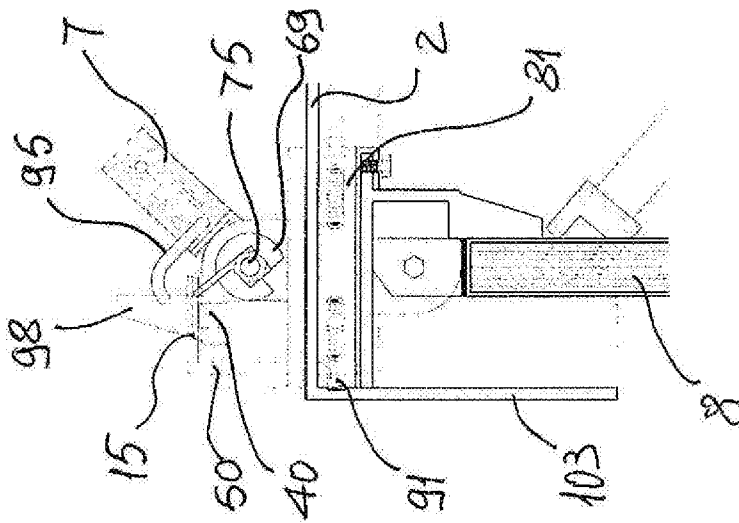

Fig. 6b

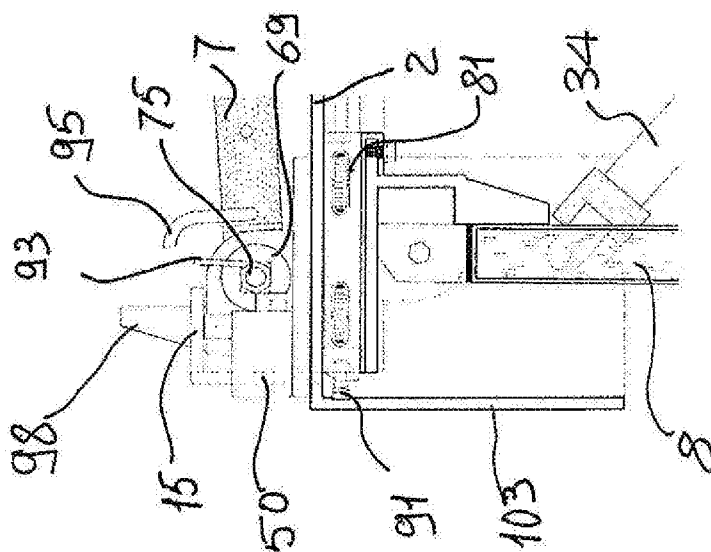

Fig. 6c

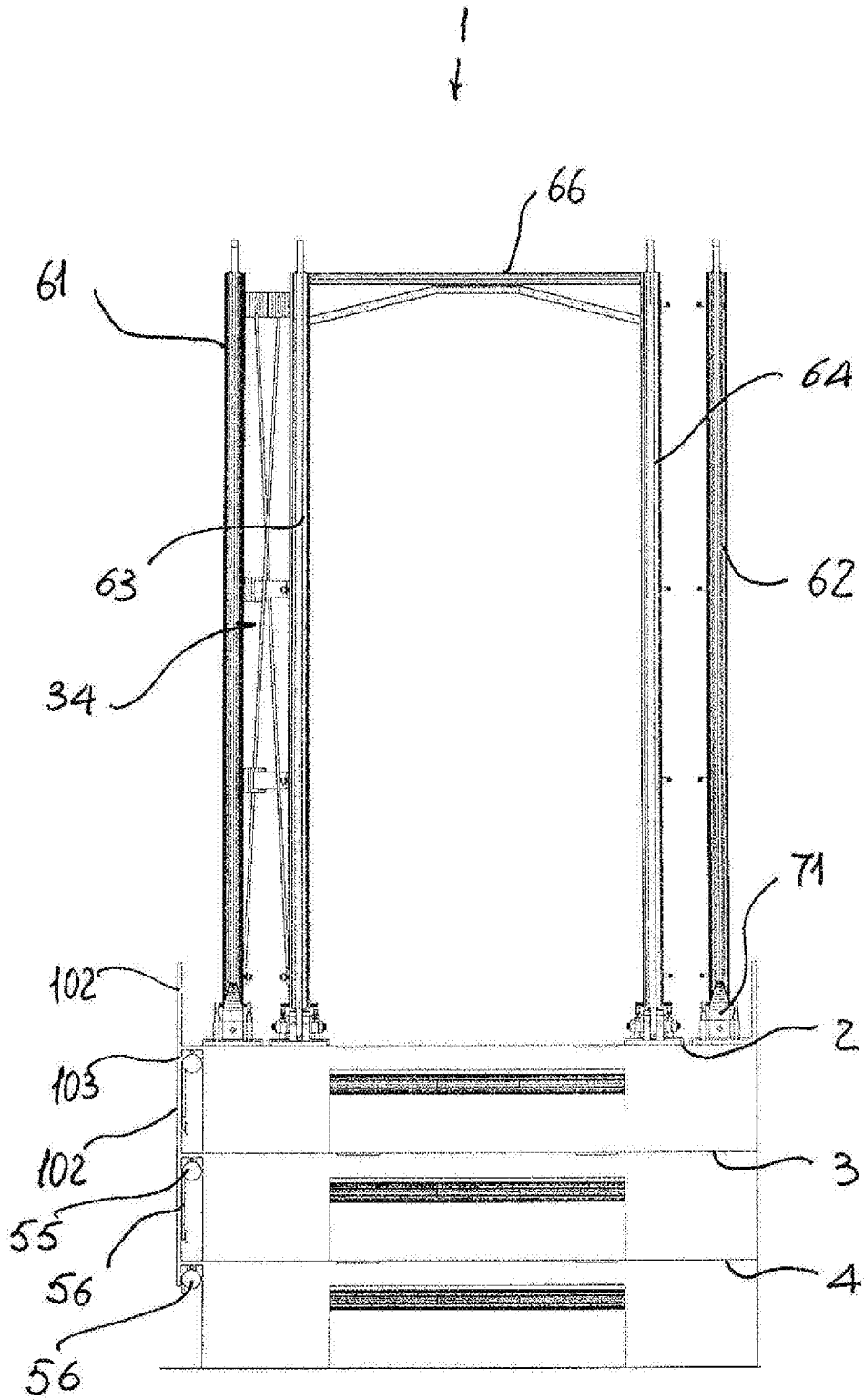

FIG. 7

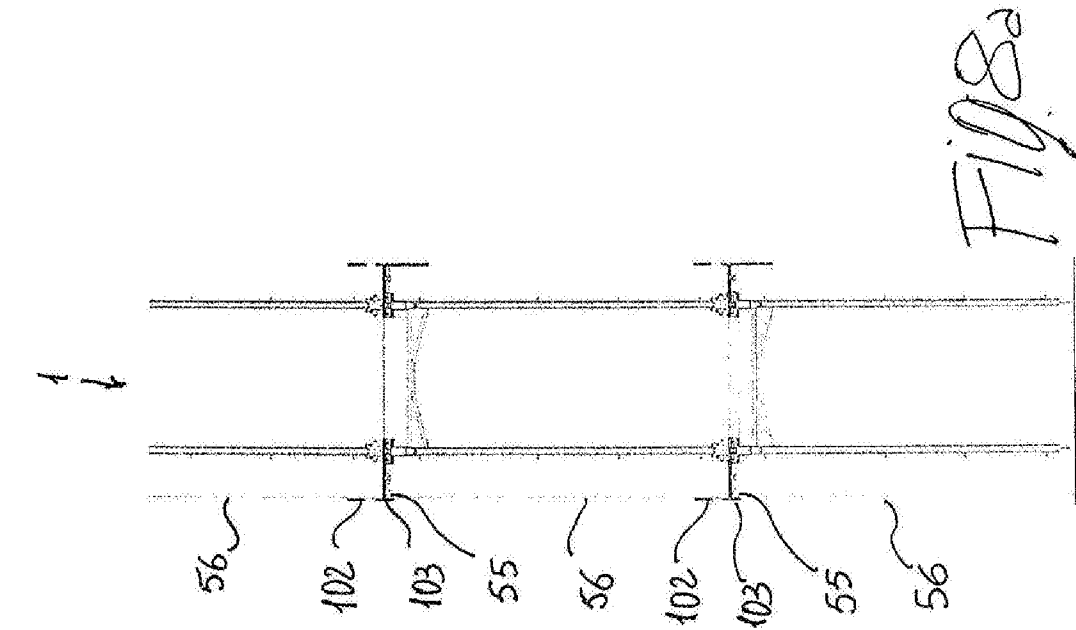

FIG. 8a

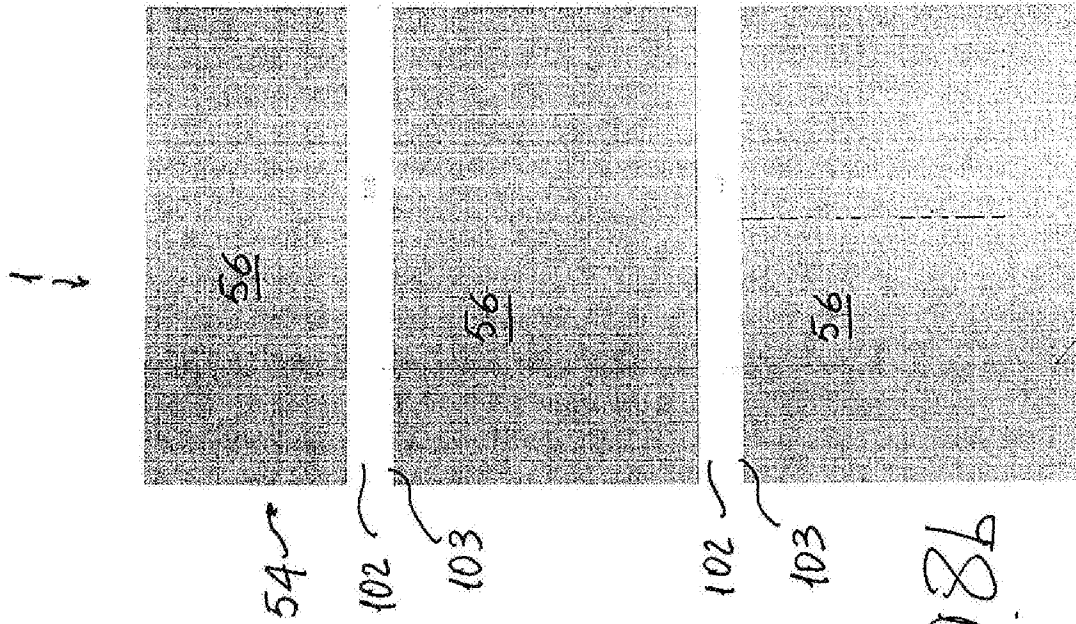

FIG. 8b

INTERNATIONAL SEARCH REPORT

International application No
PCT/EP2011/053250

A. CLASSIFICATION OF SUBJECT MATTER
INV. E04G1/34
ADD.
According to International Patent Classification (IPC) or to both national classification and IPC

B. FIELDS SEARCHED
Minimum documentation searched (classification system followed by classification symbols)
E04G

Documentation searched other than minimum documentation to the extent that such documents are included in the fields searched

Electronic data base consulted during the international search (name of data base and, where practical, search terms used)
EPO-Internal

C. DOCUMENTS CONSIDERED TO BE RELEVANT

Category*	Citation of document, with indication, where appropriate, of the relevant passages	Relevant to claim No.
X	JP 5 179796 A (DAIKI SHOJI KK) 20 July 1993 (1993-07-20) abstract; figures 1,4 -----	1-11
X	CH 662 150 A5 (EBERHARD M BUEHNENBAU WEESSEN) 15 September 1987 (1987-09-15) page 2, right-hand column, line 56 - page 3, right-hand column, line 24 -----	1-4
A	GB 2 323 623 A (CORLETT ANTONY JOHN [GB]) 30 September 1998 (1998-09-30) page 1; figures 3-5 -----	1,11

Further documents are listed in the continuation of Box C.

See patent family annex.

* Special categories of cited documents :

- "A" document defining the general state of the art which is not considered to be of particular relevance
- "E" earlier document but published on or after the international filing date
- "L" document which may throw doubts on priority claim(s) or which is cited to establish the publication date of another citation or other special reason (as specified)
- "O" document referring to an oral disclosure, use, exhibition or other means
- "P" document published prior to the international filing date but later than the priority date claimed

- "T" later document published after the international filing date or priority date and not in conflict with the application but cited to understand the principle or theory underlying the invention
- "X" document of particular relevance; the claimed invention cannot be considered novel or cannot be considered to involve an inventive step when the document is taken alone
- "Y" document of particular relevance; the claimed invention cannot be considered to involve an inventive step when the document is combined with one or more other such documents, such combination being obvious to a person skilled in the art.
- "&" document member of the same patent family

Date of the actual completion of the international search
4 July 2011

Date of mailing of the international search report
25/07/2011

Name and mailing address of the ISA/
European Patent Office, P.B. 5818 Patentlaan 2
NL - 2280 HV Rijswijk
Tel. (+31-70) 340-2040,
Fax: (+31-70) 340-3016

Authorized officer
Saretta, Guido

INTERNATIONAL SEARCH REPORT

Information on patent family members

International application No

PCT/EP2011/053250

Patent document cited in search report	Publication date	Patent family member(s)	Publication date
JP 5179796	A	20-07-1993	NONE
CH 662150	A5	15-09-1987	NONE
GB 2323623	A	30-09-1998	NONE