

March 16, 1937.

J. G. JACKSON

2,073,965

MAGNETIC BLOW-OUT DEVICE

Original Filed April 24, 1933

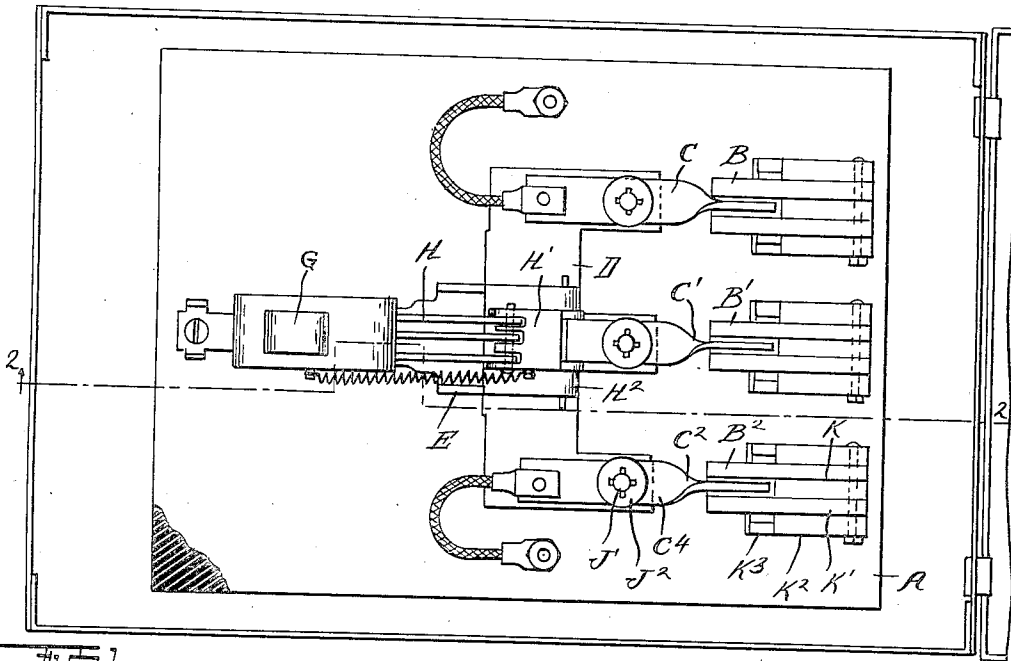

FIG. 1.

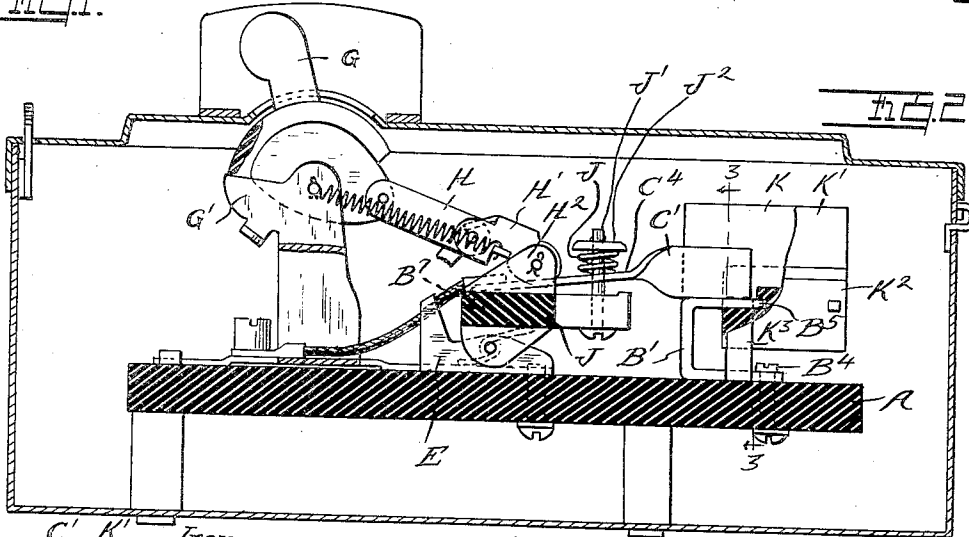

FIG. 2.

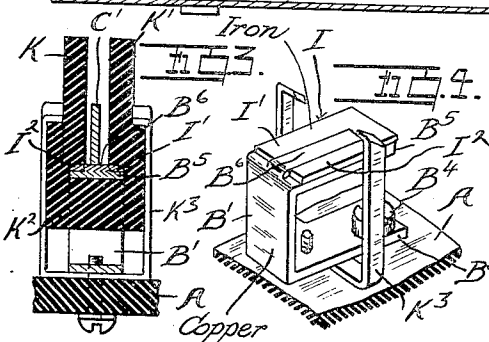

FIG. 3.

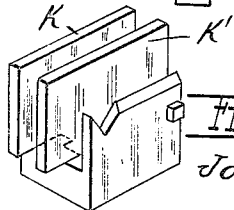

FIG. 4.

FIG. 5.

INVENTOR  
John G. Jackson

BY  
*William Fisher & William H. Bell*  
ATTORNEYS

# UNITED STATES PATENT OFFICE

2,073,965

## MAGNETIC BLOW-OUT DEVICE

John G. Jackson, Detroit, Mich., assignor to Square D Company, Detroit, Mich., a corporation of Michigan

Original application April 24, 1933, Serial No. 667,696, Patent No. 2,009,050, July 23, 1935. Divided and this application February 12, 1934, Serial No. 710,935

22 Claims. (Cl. 200-144)

The invention relates to circuit breakers and has more particular reference to the means employed for suppressing the electric arc when the contacts are separated. The present application forms a division of my prior application Serial Number 667,696, filed April 24, 1933, now Patent No. 2,009,050 issued July 23, 1935. It is the object of the invention to obtain a construction in which the arc generated upon separation of the contacts is effectively suppressed. To this end the invention consists in the peculiar construction and arrangement of a magnetic member in combination with one of the contact members and further in the combination therewith of electrical and heat insulated guard plates as hereinafter set forth.

In the drawing:

Fig. 1 is a plan view of a switch or circuit breaker to which my improvements are applied;

Fig. 2 is a cross section on line 2-2, Fig. 1;

Fig. 3 is a cross section on line 3-3 of Fig. 2;

Fig. 4 is a perspective view showing the stationary electrical contact with the magnetic deflector and with the arc deflecting housing removed therefrom;

Fig. 5 is a similar view of the removed arc deflecting housing.

My improved arc suppressing means may be applied to various constructions of electrical switches or circuit breakers, but as specifically illustrated it is applied to a circuit breaker of the following construction:

A is an insulator base plate for the circuit breaker on which are mounted the stationary contacts B, B', B<sup>2</sup> and the cooperating movable contacts C, C', C<sup>2</sup> which latter are carried by a rockable insulator member D pivotally mounted in a bracket E on the base A. A torsion spring F sleeved upon the pivot pin F' in the bracket E serves to resiliently hold the member D in open position. There is also a manually operable handle G pivotally secured upon a bracket G' connected by toggle links H, H', to a bracket H<sup>2</sup> on the rockable member D forming a means for closing the circuit and holding the contacts locked in closed position against the tension of a spring F.

For arc suppression and for guarding against welding of the stationary and movable contacts to each other, I have devised the following construction:

Each of the stationary contacts B, B', B<sup>2</sup> is formed of a bar of high electrical conductivity such as copper and preferably bent into substantially U form. The base portion B<sup>3</sup> is secured to

the base A and is provided with a connector clamping screw B<sup>4</sup>. The top portion B<sup>5</sup> is parallel to the base B<sup>3</sup> and has secured thereto a U-shaped member I of iron or other magnetic material having parallel legs I', I<sup>2</sup> overlapping said portion B<sup>5</sup> and a comparatively narrow slot or space therebetween. Filling this space is an upwardly extending tongue B<sup>6</sup> which is substantially flush with the upper face of the member I and forms the contact face for bearing against the movable contact member C. The latter is also preferably formed of a flat bar of copper or other conductive material which is twisted to have an outer end portion C<sup>3</sup> extending in a vertical plane above the tongue B<sup>6</sup> and a horizontal portion C<sup>4</sup>, the end of which rests upon the rockable member D. At the end of the portion C<sup>4</sup> is a downwardly projecting tongue B<sup>7</sup> engaging a recess in the member D to retain the contact from lateral displacement and intermediate the ends of the member C is a spring J sleeved upon a pin J' which passes upward through the member D and bar C and has a detachable collar or abutment J<sup>2</sup> for the spring at its upper end. The arrangement is such that in the closed position of the contacts the portion C<sup>4</sup> will be at an oblique angle to the member D, the spring J being tensioned to hold the portion C<sup>3</sup> against the portion B<sup>6</sup>. This also permits an acceleration of the member D during opening movement before it lifts the contact C from the cooperating contact to impart an initial higher velocity thereto.

Mounted on the member B<sup>5</sup> is a casing formed of electrical insulator and heat resisting material such as asbestos fibre with a binder of Portland or Magnesite cement and which comprises a pair of plates K K' parallel to each other on opposite sides of the portion C<sup>3</sup> and above the portions I', I<sup>2</sup> of the member I. This casing is also provided with a portion K<sup>2</sup> which surrounds the member B<sup>5</sup> and the end portion of the member I exposing only the portion B<sup>6</sup>. A spring clip K<sup>3</sup> secured to the base A and embracing the casing serves to hold the same from displacement. Thus when the metallic circuit is broken by the separation of the member C from the tongue portion B<sup>6</sup> the continued flow of current through the arc will develop a magnetic field which operates to deflect the arc outward between the plates K and K' and away from the member C<sup>3</sup>.

The tongue B<sup>6</sup> may be formed of the same material as the member B but to avoid danger of melting and welding I preferably form this tongue of an electrically conductive but heat resistant material. Thus silver may be used for

its high electrical conductivity and may be alloyed with some high fusing metal such as tungsten or molybdenum, or other similar metals. The small amount of material required for making the tongue will permit the use of such expensive metals without greatly adding to the cost of the structure.

The arc suppressing means as above described is exceedingly simple in construction and effective in operation. It will be noted that the U-shaped magnetic member is completely protected by the insulator housing and at the same time the legs of the U extend in fairly close proximity to each other. This will develop a strong magnetic field which reacts upon the arc to expel it in an outward direction away from the contacts C<sup>3</sup> and B<sup>6</sup>, and towards the closed end of the U. It will also be noted that the insulator housing thoroughly protects all portions of the stationary electrical contact members with the exception of the tongue B<sup>6</sup>, and this portion is preferably formed of an alloy having a high fusing point so as to avoid any danger of welding to the movable contact.

25 What I claim as my invention is:

1. In a circuit breaker, the combination with fixed and movable contact members, of a U-shaped magnetic member mounted directly on one of said contact members with the legs thereof in a plane substantially parallel to its contacting surface and exposing only sufficient surface between the legs of the U for engagement with the cooperating contact member.

2. In a circuit breaker, the combination with fixed and movable contact members, each of oblong cross section, said movable contact being in a plane transverse to the plane of said fixed contact, and a U-shaped magnetic member mounted on the contact face of said fixed contact with only sufficient width between the legs of the U for engagement with said movable contact.

3. In a circuit breaker, the combination with fixed and movable contacts, of a U-shaped magnetic member mounted on the face of one of said contacts and exposing only sufficient area between the legs of the U for engagement with the cooperating contact, and parallel barrier plates mounted on said first mentioned contact and covering said U-shaped magnetic member.

4. In a circuit breaker, the combination with fixed and movable contacts of oblong cross section, the movable contact being arranged and movable in a plane transverse to the plane of the fixed contact and centrally thereof, a U-shaped magnetic member mounted directly on said fixed contact exposing only sufficient area of the latter for engagement with said movable contact, and barrier plates mounted directly on said fixed contact on opposite sides of said movable contact and covering said U-shaped magnetic member.

5. In a circuit breaker, the combination with fixed and movable contacts of oblong cross section, the movable contact being arranged and movable in a plane transverse to the plane of the fixed contact and centrally thereof, a U-shaped magnetic member mounted directly on said fixed contact in a plane substantially parallel to its contacting surface with only sufficient width between the legs of the U for engagement with said movable contact, a tongue on said fixed contact projecting upward between the legs of the U and slightly above the upper surface thereof, and barrier plates mounted di-

rectly on said fixed contact on opposite sides of said tongue and movable contact and enclosing said U-shaped member.

6. In a circuit breaker, the combination with fixed and movable contacts, of a U-shaped magnetic member mounted on one of said contacts in a plane substantially parallel to its contacting surface and exposing only sufficient surface between the legs of the U for engagement with the cooperating contact, and a tongue projecting between the legs of the U formed of highly conductive non-welding material.

7. In a circuit breaker, the combination with fixed and movable contacts of oblong cross section, said movable contact being in a plane transverse to the plane of said fixed contact and centrally thereof, a U-shaped magnetic member mounted directly on said fixed contact in a plane substantially parallel to its contacting surface with only sufficient width between the legs of the U for engagement of said movable contact, a tongue projecting from said fixed contact between the legs of the U and formed of highly conductive non-welding material, and barrier plates mounted directly on said fixed contact on opposite sides of said tongue and movable contact and enclosing said U-shaped member.

8. In a circuit breaker, the combination with fixed and movable contact members, said movable contact member being arranged and movable in a plane transverse to the plane of said fixed contact, and a U-shaped magnetic member mounted directly on said fixed contact with the legs thereof in a plane substantially parallel to its contacting surface with sufficient width between the legs of the U for engagement with said movable contact.

9. In a circuit breaker, the combination with fixed and movable contacts, of a U-shaped magnetic member mounted directly on the face of one of said contacts in a plane substantially parallel to its contacting surface and exposing sufficient area between the legs of the U for engagement with the cooperating contact, and parallel barrier plates mounted directly on said first mentioned contact and covering at least a portion of said U-shaped magnetic member.

10. In a circuit breaker, the combination with fixed and movable contacts, the movable contact being arranged and movable in a plane transverse to the plane of the fixed contact and centrally thereof, a U-shaped magnetic member mounted on said fixed contact in a plane substantially parallel to its contacting surface exposing sufficient area of the latter for engagement with said movable contact, and barrier plates mounted directly on said fixed contact on opposite sides of said movable contact and covering at least a part of said U-shaped magnetic member.

11. In a circuit breaker, the combination with fixed and movable contacts, the movable contact being arranged and movable in a plane transverse to the plane of the fixed contact and centrally thereof, a U-shaped magnetic member mounted directly on said fixed contact in a plane substantially parallel to its contacting surface with sufficient width between the legs of the U for engagement with said movable contact, a tongue on said fixed contact projecting upward between the legs of the U, and barrier plates mounted directly on said fixed contact on opposite sides of said tongue and movable contact and enclosing at least a part of said U-shaped member.

12. In a circuit breaker, the combination with fixed and movable contacts, said movable contact being arranged and movable in a plane transverse to the plane of said fixed contact, and an insulator member including parallel barrier plates on opposite sides of said movable contact member and slotted to be slidably engageable with the opposite edge portions of said fixed contact member. 5
13. In a circuit breaker, the combination with fixed and movable contacts, the fixed contact extending laterally beyond the opposite sides of said movable contact, and an insulator member having parallel portions adjacent to said movable contact member, a portion extending beneath said fixed contact member and being slotted for engagement with the laterally projecting portions of said fixed contact member and thereby secured thereto. 10
14. A composition contact for a circuit breaker having a U-shaped magnetic portion, a contact portion between the legs of the U and a conducting portion overlapped by said legs. 15
15. A composition contact for a circuit breaker comprising a U-shaped magnetic portion closed at one end and having pole portions at the opposite end, a conducting contact portion located between the legs of the U-shaped magnetic portion and a conducting portion adjacent to and overlapped by said legs. 20
16. A contact for circuit breaker including a conducting portion and a U-shaped magnetic plate mounted on the contact face thereof with its legs spaced apart to expose a contacting surface. 25
17. In a circuit controlling device, fixed and movable contact members and a substantially U-shaped magnetic member mounted with its legs on either side of and with the plane of said legs closely adjacent to the point of separation of said contacts and substantially parallel barrier plates mounted over said magnetic member on either side of the plane of movement of said movable contact. 30
18. In a circuit controlling device, fixed and movable contacts and a flat magnetic member positioned closely adjacent to the point of break of said contacts with its plane substantially parallel to the contact surface of said fixed contact, said member having a slot therein exposing sufficient surface of said fixed contact for engagement with said movable contact, and substantially parallel barrier plates mounted over said magnetic member on either side of the plane of movement of said movable contact. 35
19. In a circuit breaker, fixed and movable contacts, said fixed contact having a flat face, a plate-like, U-shaped magnetic member mounted on said face and exposing only sufficient surface between the legs of the U for engagement with said movable contact, and a tongue on said fixed contact substantially filling the slot between the legs of the U. 5
20. In a circuit breaker, fixed and movable contacts, said fixed contact having a flat face, a plate-like, U-shaped magnetic member mounted on said face and exposing only sufficient surface between the legs of the U for engagement with said movable contact, and a tongue of highly conducting non-welding material on said fixed contact substantially filling the slot between the legs of the U. 10
21. In a circuit breaker, fixed and movable contacts, said fixed contact having a flat face, a plate-like, U-shaped magnetic member mounted with its plane parallel and closely adjacent to said face and exposing only sufficient surface between the legs of the U for engagement with said movable contact, and parallel barrier plates disposed on either side of said movable contact and over said member, said plates being spaced apart a distance substantially equal to the spacing between the legs of said U. 15
22. In a circuit breaker, fixed and movable contacts, said fixed contact having a flat face, a plate-like, U-shaped magnetic member mounted on said face and exposing only sufficient surface between the legs of the U for engagement with said movable contact, a tongue on said fixed contact substantially filling the slot between the legs of the U, and parallel barrier plates disposed on either side of said movable contact and over said member, said plates being spaced apart a distance substantially equal to the spacing between the legs of said U. 20

JOHN G. JACKSON.