

(19) World Intellectual Property  
Organization  
International Bureau



(43) International Publication Date  
10 June 2004 (10.06.2004)

PCT

(10) International Publication Number  
**WO 2004/049395 A2**

- (51) International Patent Classification<sup>7</sup>: **H01L**
- (21) International Application Number:  
PCT/US2003/033767
- (22) International Filing Date: 24 October 2003 (24.10.2003)
- (25) Filing Language: English
- (26) Publication Language: English
- (30) Priority Data:  
60/429,082 25 November 2002 (25.11.2002) US  
10/672,655 25 September 2003 (25.09.2003) US

(81) Designated States (*national*): AE, AG, AL, AM, AT, AU, AZ, BA, BB, BG, BR, BY, BZ, CA, CH, CN, CO, CR, CU, CZ, DE, DK, DM, DZ, EC, EE, ES, FI, GB, GD, GE, GH, GM, HR, HU, ID, IL, IN, IS, JP, KE, KG, KP, KR, KZ, LC, LK, LR, LS, LT, LU, LV, MA, MD, MG, MK, MN, MW, MX, MZ, NI, NO, NZ, OM, PG, PH, PL, PT, RO, RU, SC, SD, SE, SG, SK, SL, SY, TJ, TM, TN, TR, TT, TZ, UA, UG, US, UZ, VC, VN, YU, ZA, ZM, ZW.

(71) Applicant (*for all designated States except US*): CAS-CADE MICROTECH, INC. [US/US]; 2430 NW 206th Avenue, Beaverton, OR 97006 (US).

(84) Designated States (*regional*): ARIPO patent (GH, GM, KE, LS, MW, MZ, SD, SL, SZ, TZ, UG, ZM, ZW), Eurasian patent (AM, AZ, BY, KG, KZ, MD, RU, TJ, TM), European patent (AT, BE, BG, CH, CY, CZ, DE, DK, EE, ES, FI, FR, GB, GR, HU, IE, IT, LU, MC, NL, PT, RO, SE, SI, SK, TR), OAPI patent (BF, BJ, CF, CG, CI, CM, GA, GN, GQ, GW, ML, MR, NE, SN, TD, TG).

(72) Inventors; and  
(75) Inventors/Applicants (*for US only*): DUNKLEE, John [US/US]; 10440 S.W. Terrace, Tigard, OR 97224 (US). COWAN, Clarence, E. [US/US]; 13710 NE Chehalem Drive, Newberg, OR 97132 (US).

**Declaration under Rule 4.17:**  
— of inventorship (*Rule 4.17(iv)*) for US only

(74) Agent: RUSSELL, Kevin, L.; Chernoff Vilhauer McClung & Stenzel LLP, 1600 OSD Tower, 601 SW Second Avenue, Portland, OR 97204 (US).

**Published:**  
— without international search report and to be republished upon receipt of that report

*For two-letter codes and other abbreviations, refer to the "Guidance Notes on Codes and Abbreviations" appearing at the beginning of each regular issue of the PCT Gazette.*

(54) Title: PROBE STATION WITH LOW INDUCTANCE PATH

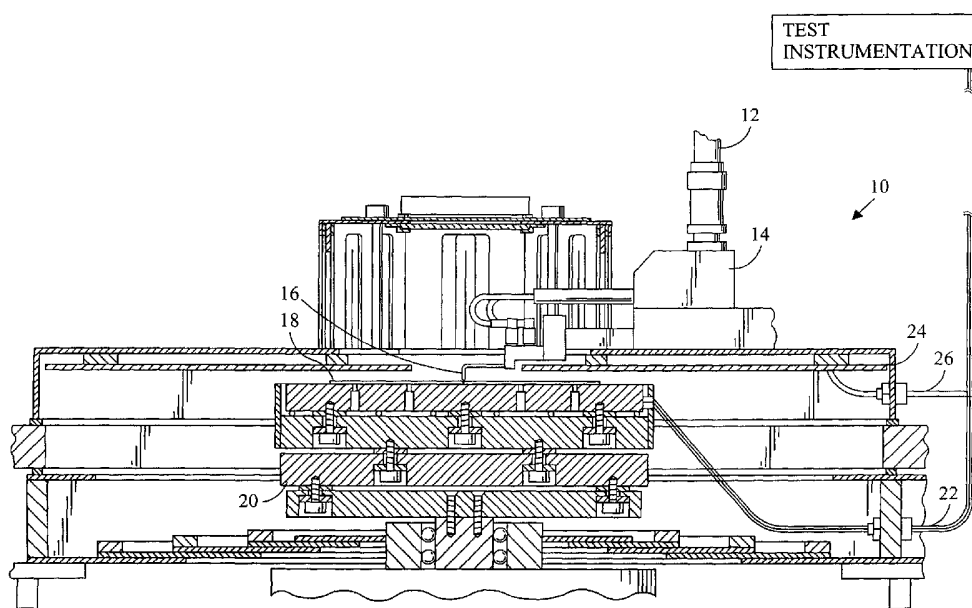

(57) Abstract: A probe assembly suitable for high-current measurements of an electrical device.

WO 2004/049395 A2

## PROBE STATION WITH LOW INDUCTANCE PATH

## BACKGROUND OF THE INVENTION

The present invention relates to probe stations, commonly known as  
5 package or wafer probers, used manually, semi-automatically, or fully automatically to  
test electrical devices such as semiconductor wafers.

Existing probe stations are capable of performing both low-current and  
high frequency measurements in an electronically quiet environment. The environment  
may be provided by, for example, incorporating one or more guard and electromagnetic  
10 interference (EMI) shield structures within an environmental enclosure. Guard and EMI  
shield structures are well known and discussed extensively in technical literature. See,  
for example, an article by William Knauer entitled "Fixturing for Low Current/Low  
Voltage Parametric Testing" appearing in *Evaluation Engineering*, November, 1990,  
pages 150-153. Examples of existing probe stations that provide such guard and EMI  
15 shield structures can be found in commonly owned U.S. Patent Nos. 5,434,512; and  
5,266,889 which are hereby incorporated by reference.

Probe stations deliver a test signal to an electrical device, such as a  
semiconductor wafer, whose characteristics are to be measured. Test conditions are  
desirably controlled and substantially free of electromagnetic interference, though not  
20 necessarily, that may emanate from test instrumentation or other nearby electrical  
equipment, or that may result from spurious air currents or the like. To provide a  
controlled and substantially noise-free test environment, existing probe stations that  
incorporate guard structures will usually at least partially surround the test signal path  
with a guard signal that closely approximates the test signal, thus inhibiting  
25 electromagnetic current leakage from the test signal path to its immediately surrounding  
environment. Similarly, EMI shield structures may provide a shield signal to the  
environmental enclosure surrounding much of the perimeter of the probing environment.  
The environmental enclosure may typically be connected to shield, earth ground,  
instrumentation ground, or some other desired potential.

To provide test, guard, and shield signals to the probe station, existing probe stations often include a multistage chuck upon which the electrical device rests while being tested. The top stage of the chuck, which supports the electrical device, typically comprises a solid, electrically conductive metal plate through which the test  
5 signal may be routed. A middle stage and a bottom stage of the chuck similarly comprise solid electrically conductive plates through which a guard signal and a shield signal may be routed, respectively. In this fashion, an electrical device resting on such a multistage chuck may be both guarded and shielded from below. Similarly, single stage and dual stage chucks, and chucks with substantial openings centrally defined therein are likewise  
10 frequently employed.

Further reduction in interference can be obtained by locating a suspended conductive plate over the electrical device which is typically electrically insulated from the test signal path and connected to the guard signal. The suspended plate defines a central opening so that the probe assembly may make electrical contact with the electrical  
15 device. In this fashion, the electrical device can be guarded from both below and above by signals closely approximating that delivered to the electrical device.

Though such a probe station is effective in performing low-current testing and high frequency testing of electrical devices, the aforementioned existing probe stations unfortunately often exhibit significant inductance to high current measurements, and particularly when testing using pulsed signals. The high inductance tends to resist  
20 fast changes in the current levels, and results in higher than desirable voltage and current levels.

What is desired, therefore, is a probe station that is suitable for performing high current and/or pulsed tests.

25

#### BRIEF DESCRIPTION OF THE SEVERAL VIEWS OF THE DRAWINGS

FIG. 1 shows a schematic of an existing probe station having guard and electromagnetic shield structures.

FIG. 2 illustrates a general schematic of FIG. 1.

FIG. 3 shows schematic of a modified probe station exhibiting reduced inductance.

FIG. 4 illustrates a general schematic of FIG. 3.

FIG. 5 shows schematic of another modified probe station exhibiting reduced inductance.

FIG. 6 shows schematic of yet another modified probe station exhibiting reduced inductance.

FIG. 7 shows schematic of a further modified probe station exhibiting reduced inductance.

FIG. 8 shows schematic of a modified probe station exhibiting reduced inductance.

#### DETAILED DESCRIPTION OF THE PREFERRED EMBODIMENT

FIG. 1 shows a general schematic diagram of an existing probe station having guard and electromagnetic shield structures. A test signal is provided through a test path 12 to a probe 14 having probe needles 16 that contact an electrical device 18 resting upon a chuck 20. The probe needles may alternatively be any type of contacts, such as for example, probe cards, probes on movable positioners, optical signals, and membrane probes. The chuck 20 receives a guard signal through a first transmission line 22 while a suspended guard member 24 receives a guard signal through a second transmission line 26. The first transmission line 22 likewise includes a test signal path to the chuck 20. The first transmission line 22, the test path 12, the probe 14, the needles 16, the device 18, and the chuck 20 together form a large loop, as shown in FIG. 1, to a common signal source at the test instrumentation. Normally within the probe station the transmission line 22 is within a service loop that is several feet long to accommodate movement of the chuck 20.

The present inventors came to the realization that when using high current or pulsed tests, the large test loop that originates from the test equipment and passes

through the chuck creates undesirable inductance. The inductance resulting from this large loop often interferes with test measurements, and in particular high current and/or pulsed signals. In addition, the transmission line 22 is normally a small conductor which is not especially suitable for carrying high currents. FIG. 2 illustrates more schematically the resulting test loop for purposes of clarity.

The present inventors further determined that reducing or otherwise modifying this previously unrecognized source of inductance for high current and/or pulsed signals, namely, the inductive test loop could improve such measurements. The modification may include modifying or otherwise providing another test signal path from the chuck 20 to the test instrumentation. FIG. 3 shows one embodiment of a probe station 10 with a test loop having a decreased length. Rather than routing the test signal from the chuck 20 through transmission line 22, a transmission line 28 may interconnect the chuck 20 with the suspended guard member 24, which is then electrically connected to the test instrumentation by another transmission line 29. The suspended guard member 24 typically has its guard potential removed when performing this test. Accordingly, the suspended guard member 24 is being used in a non-traditional manner, namely, not interconnected to a guard potential. The interconnection of the transmission line 28 at the chuck 20 may be one of the layers of the chuck 20 such as the top layer of the chuck 20. The at least partially encircling conductive member 33, normally connected to guard potential, may have a height greater than the top surface of the chuck, even with the top surface of the chuck, or below the top surface of the chuck. Preferably, there is an air gap between the conductive member 33 and the chuck 20. The air gap may be partially filled, substantially filled, or completely filled with dielectric material. The signal path to or from the top surface of the chuck may be provided through an opening in the conductive member 33. Electrically connecting the chuck 20 to the suspended guard member 24 by the transmission line 28, and to the test instrumentation by transmission line 29, results in a smaller loop path than that provided by previously existing probe stations, as shown schematically in FIG. 4. By reducing the length of the test path loop, electrical

performance is improved, particularly when testing an electrical device using high-current and/or pulsed signals.

It is to be understood that the suspended plate may be suspended from above, typically using insulators, or supported by supports from within the probe station, or supported by the chuck or chuck assembly. Normally the suspended plate does not  
5 move together with the chuck 20, but is rather maintained in a fixed spatial relationship with respect to the probe station 10. Also, it is to be understood that the suspended plate may be any conductive member within the probe station that has the characteristic that it does not move together with the chuck 20, but is rather maintained in a fixed spatial  
10 relationship with respect to the probe station 10. Alternatively, the suspended member may be any conductive member within the probe station that is free from being electrically connected to a guard and/or shield potential when used in the aforementioned configuration.

The interconnections from the chuck 20 to the suspended guard 24 is  
15 preferably totally within the environmental enclosure. A further explanation of the environmental enclosure is disclosed in U.S. Patent No. 5,457,398, incorporated by reference herein. Interconnection within the environmental enclosure potentially reduces the length of the conductive path to less than it would have been had the interconnection been, at least in part, exterior to the environmental enclosure, or otherwise the test path  
20 passing from within the environmental enclosure to outside the environmental enclosure to within the environmental enclosure.

The transmission lines 28 and 29, shown schematically in FIGS. 2-4 may be embodied in many different structures. For example, the transmission lines 28 and 29 may be a traditional transmission line, such as a wire, coaxial cable, triaxial cable, and  
25 one or more conductive tabs. Alternatively, as depicted in FIG. 5, the transmission line 28 may comprise a conductive shell or bowl 50 that contacts the test path of the chuck 20 (e.g., top layer) at its lower end and the suspended plate 24 at its upper end. The shell 50 preferably encircles a major portion of the chuck 20 and more preferably substantially all of the chuck 20. In addition, the shell 50 while preferably forming a substantially closed

loop may have a size less than, at least in part, the exterior periphery defined by the chuck 20. Also, preferably the conductive shell 50 includes a flexible upper portion in contact with the suspended member so that upon pressing engagement a good conductive interconnection is made even while the conductive shell 50 moves horizontally relative to the suspended plate 24. Moreover, the shell 50 may be detachably engageable with the suspended member by changing its height, such as for example, using “flip-up” fingers. In addition, a flexible upper portion also permits a greater range of movement of the chuck in the z-axis direction. In addition, the shell may be solid, flexible, and/or perforated with openings as desired. The openings, in particular, may be useful for permitting air flow around the device under test.

Referring to FIG. 6, the reduced inductance test path may be included within the structure that includes an enclosure 37 that surrounds the chuck therein. During testing of the device under test the enclosure 37 moves together with the chuck 20. The interconnection 28 to the suspended member may be by a cable or otherwise from a location within the chamber or otherwise connected to the chuck therein.

Referring to FIG. 7, a dual probe assembly may be used to provide a test signal path. A first probe 70 may provide a test signal to the device under test. The test signal then passes through the device under test and to the chuck 20. The chuck 20 is electrically interconnected to the suspended plate 24. A second probe 72 may receive the test signal from the suspended plate 24. Alternatively, the second probe 72 may be directly interconnected to the chuck 20 to receive the test signal.

Referring to FIG. 8, a single probe assembly 80 may be used to provide and sense a test signal path. The probe 80 may provide a test signal to the device under test through a first probe tip 82. The test signal then passes through the device under test and to the chuck 20. The chuck 20 is electrically interconnected to the suspended plate 24. The single probe assembly 80 may receive the test signal from the suspended plate 24 through a second probe tip 84. Alternatively, the second tip of the probe assembly 80 may be direct interconnection to the chuck 20 to receive the test signal. In this manner a single probe assembly may both provide the test signal and sense the test signal. Also, it

is preferred that the interconnected from the probe assembly 80 to the test instrumentation is a single cable assembly, more preferably a twisted pair of wires, to minimize inductance. The twisted pair of wires preferably extends at least 50% of the distance between the probe and the test instrumentation.

5                   The terms and expressions employed in the foregoing specification are used therein as terms of description and not of limitation, and there is no intention in the use of such terms and expressions of excluding equivalents of the features shown and described or portions thereof, it being recognized that the scope of the invention is defined and limited only by the claims that follow.



## CLAIMS

1. A probe assembly for probing an electrical device, said probe assembly comprising:
- 5 (a) a chuck having a first conductive member suitable for supporting an electrical device; and
- (b) a second conductive member spaced apart from said chuck, wherein said electrical device is spaced between said first conductive member and said second conductive member, wherein
- 10 said first conductive member is electrically interconnected to said second conductive member, wherein said first conductive member and said second conductive member are electrically connected to the same potential.
- 15 2. The probe assembly of claim 1 wherein said second conductive member is electrically interconnected to a test signal of said electrical device.
3. The probe assembly of claim 1 wherein said first conductive member comprises a first plate, said second conductive member comprises a
- 20 second plate, and wherein said second conductive member is spaced further distant from said electrical device than said first conductive member.
4. The probe assembly of claim 1 wherein said second conductive member
- 25 comprises a second plate and is vertically spaced apart from said first conductive member.

5. The probe assembly of claim 1 wherein said second conductive member is electrically interconnected to said first conductive member completely within an environmental chamber.
- 5 6. The probe assembly of claim 1 wherein said second conductive member is free from being supported by said chuck.
7. The probe assembly of claim 1 wherein said first conductive member is electrically interconnected to a first probe, wherein said second conductive member is electrically interconnected to a second probe.
- 10 8. The probe assembly of claim 1 wherein said first conductive member and said second conductive member are electrically interconnected to a first probe.
- 15 9. The probe assembly of claim 1 wherein said first probe is electrically interconnected to test instrumentation using a twisted pair of wires over at least 50% of the distance between said first probe and said test instrumentation.
- 20 10. The probe assembly of claim 1 further comprising a detachable substantially closed loop member engageable with said first conductive member and said second conductive member, where said loop member includes a flexible member interconnecting said first conductive member and said second conductive member.
- 25

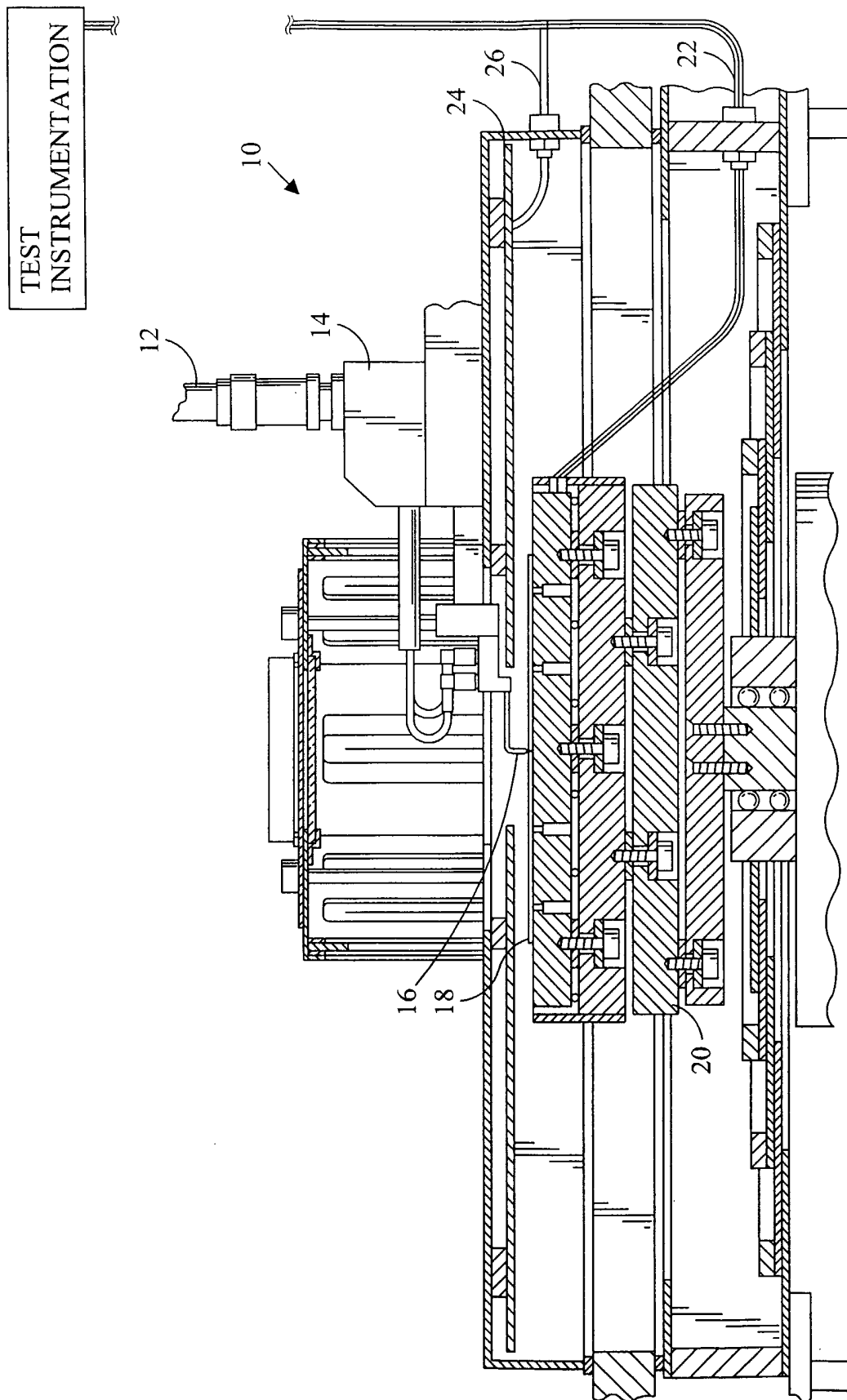

FIG. 1

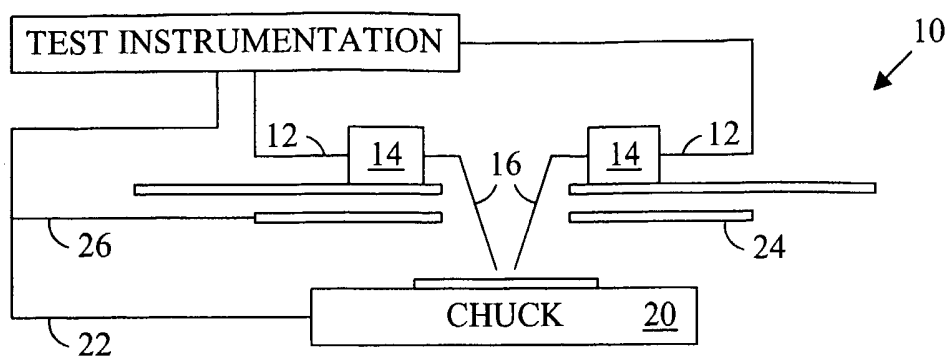

FIG. 2

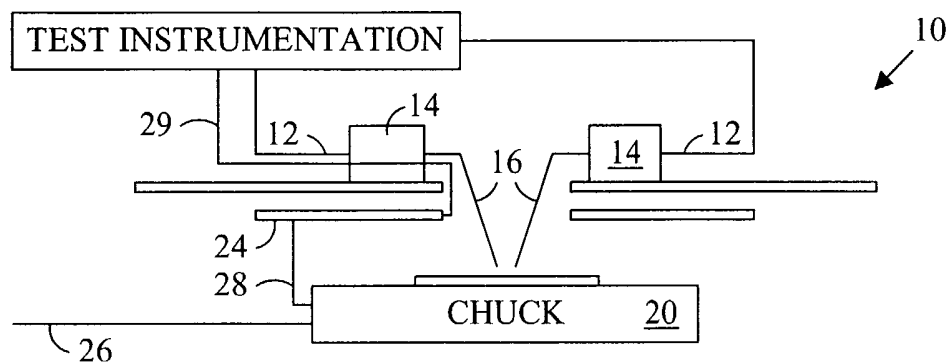

FIG. 4

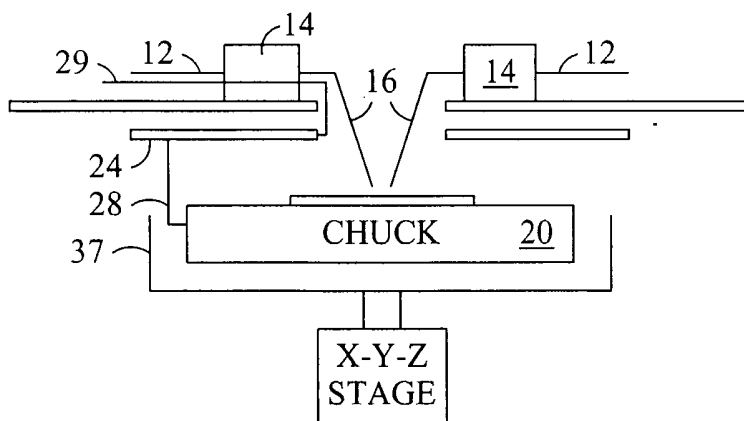

FIG. 6

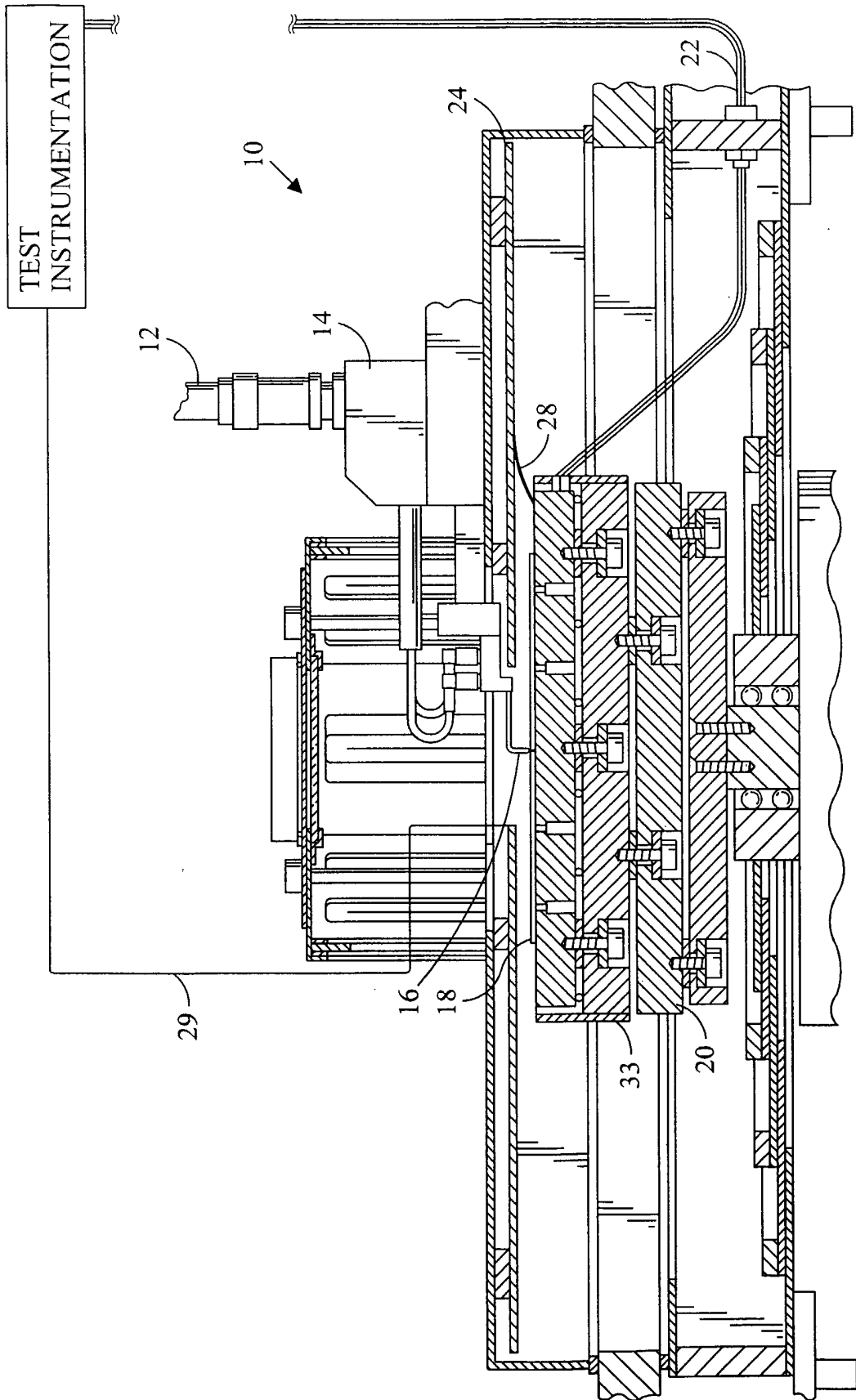

FIG. 3

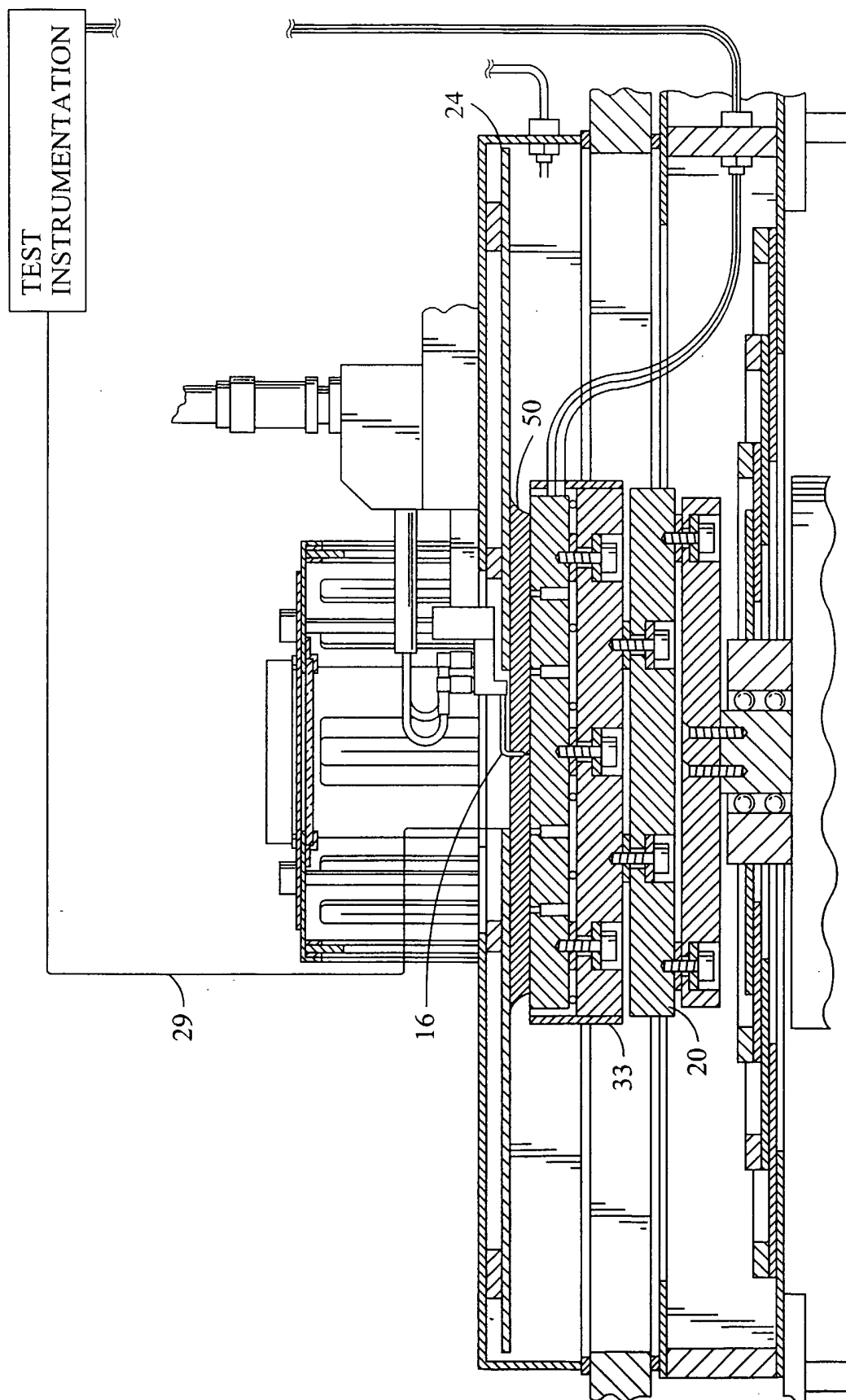

FIG. 5

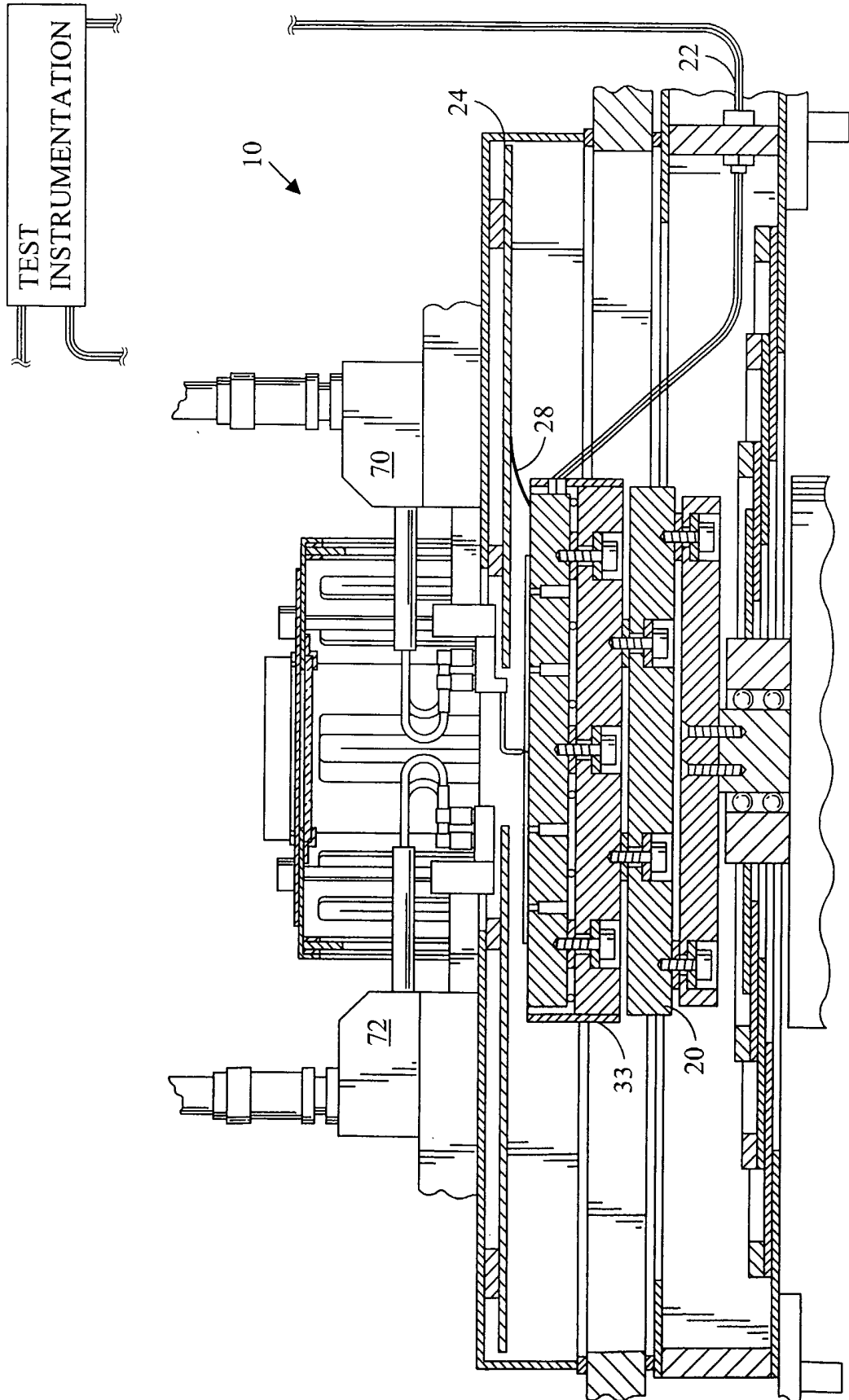

FIG. 7

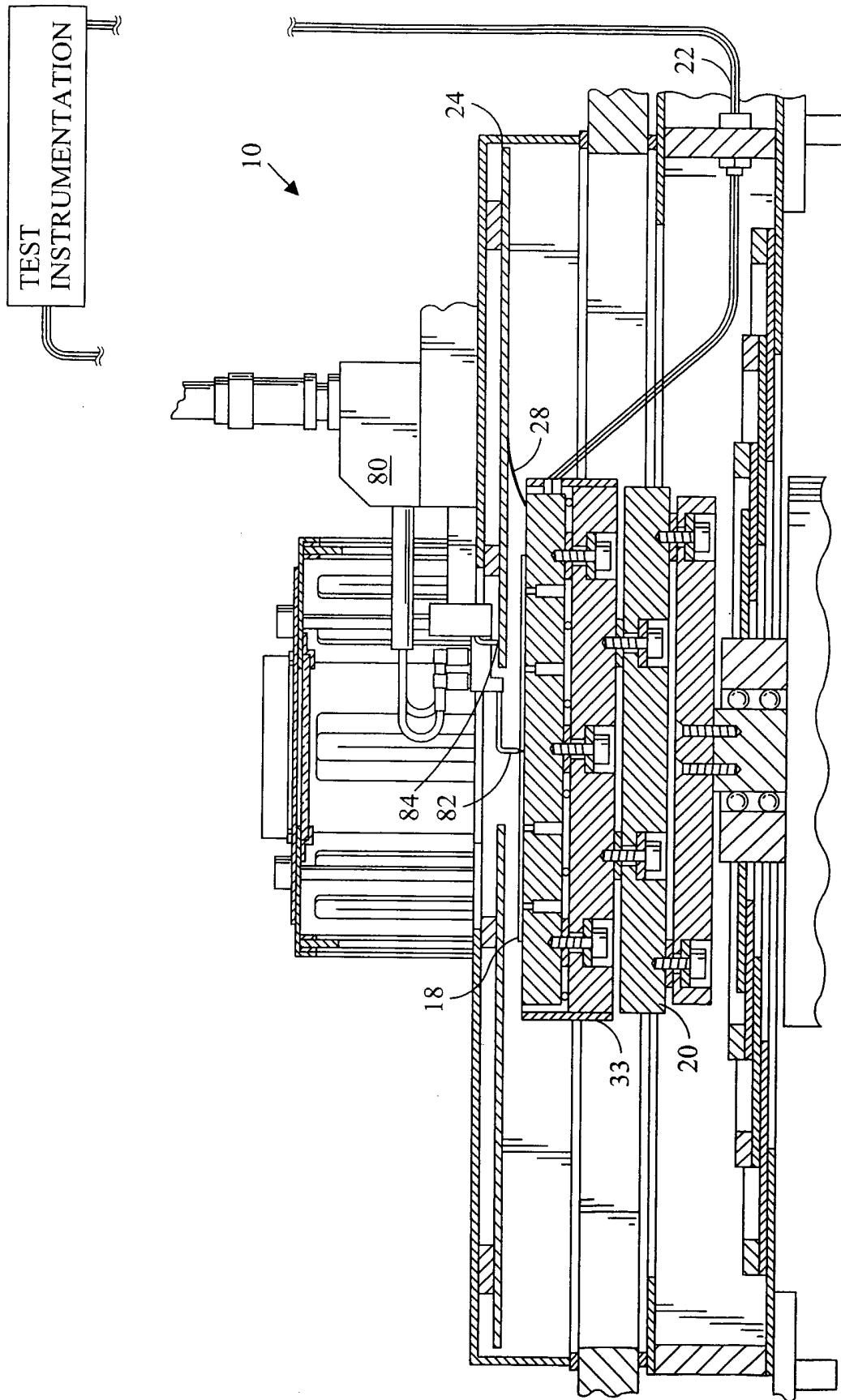

FIG. 8