

A. SYMES.
DISPLAY APPARATUS.
APPLICATION FILED MAY 19, 1904.

4 SHEETS—SHEET 1.

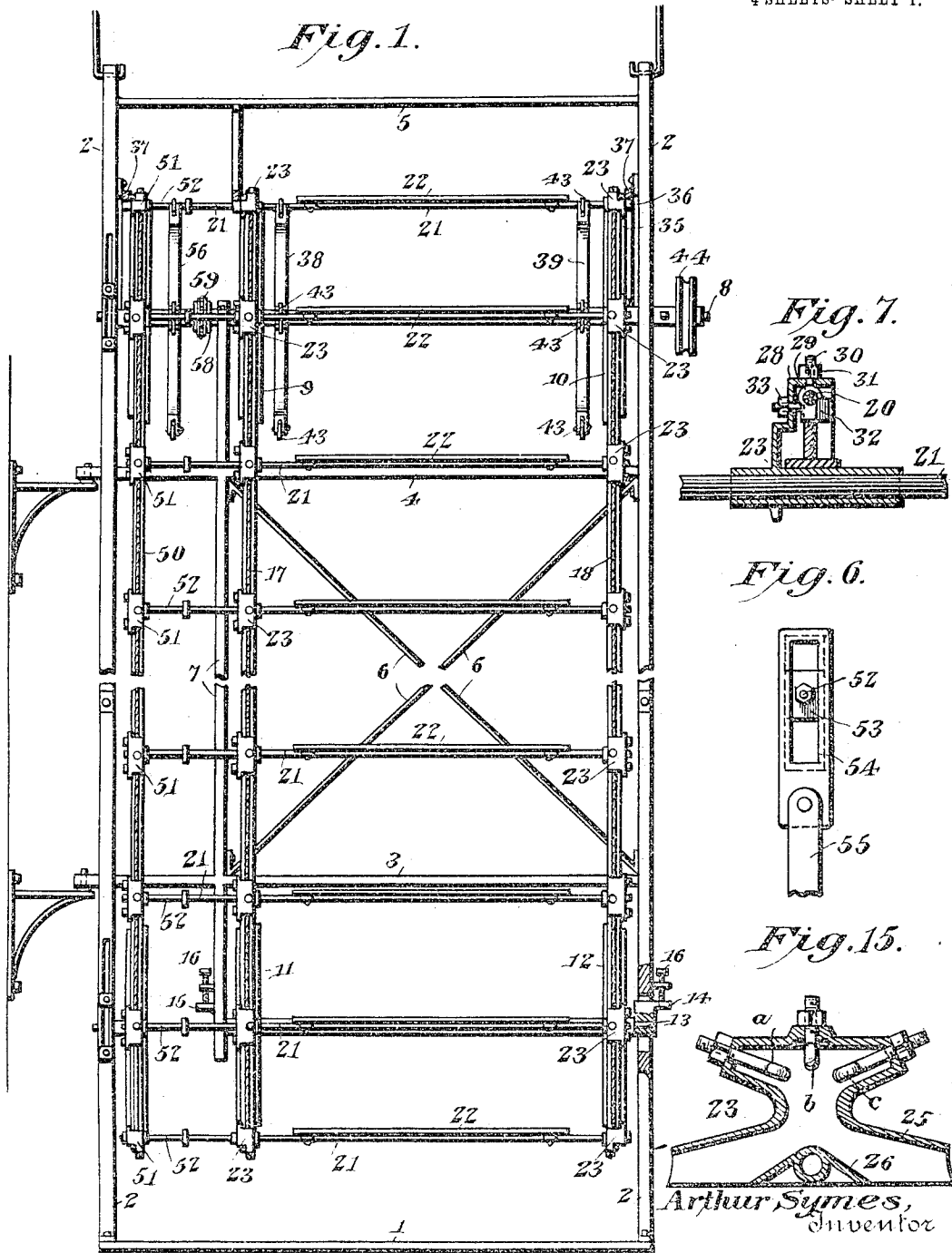

Witnesses
Jas. E. McLaughlin
Louis L. Gulik

354
E. G. Figgess
Attorney

A. SYMES.
DISPLAY APPARATUS.
APPLICATION FILED MAY 19, 1904.

4 SHEETS—SHEET 2.

Fig. 2.

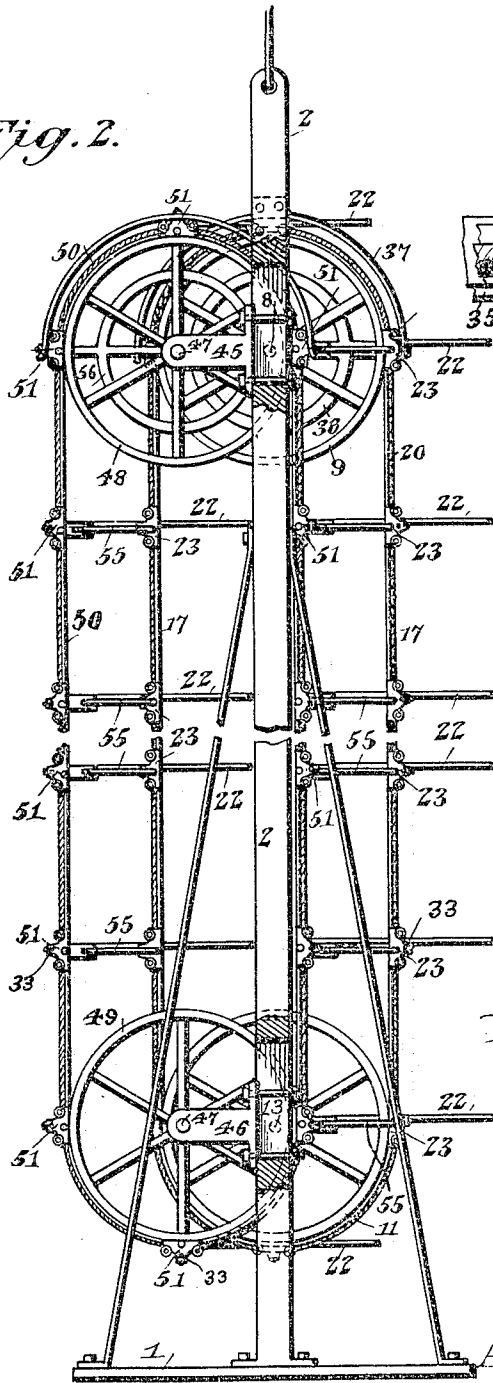

Fig. 8.

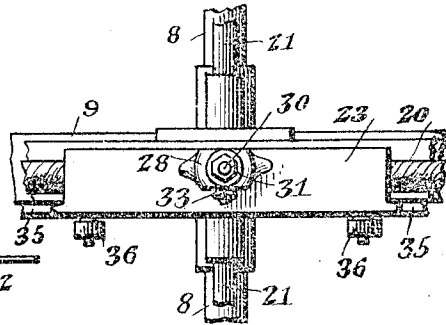

Fig. 9.

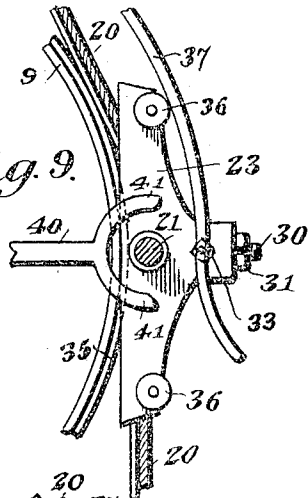
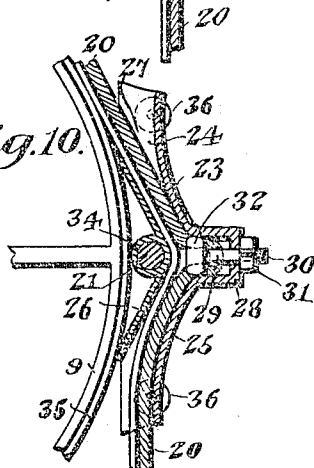

Fig. 10.



Arthur Symes, Inventor

Witnesses
 Jas. E. McCathran
 Louis E. Gulikn

331

E. G. Siggers
 Attorney

A. SYMES.
DISPLAY APPARATUS.
APPLICATION FILED MAY 19, 1904.

4 SHEETS—SHEET 3.

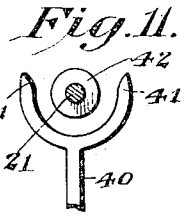
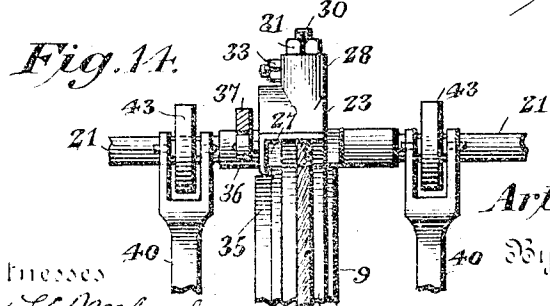
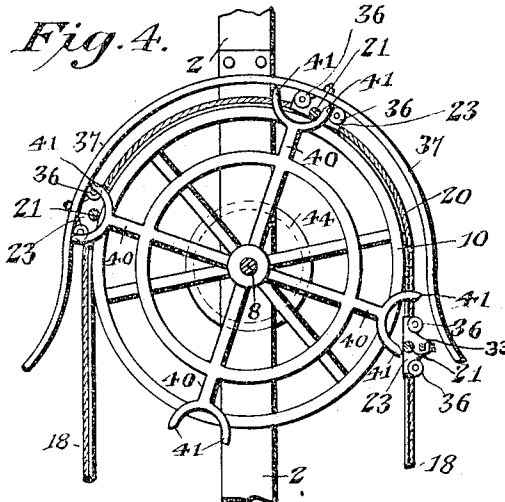
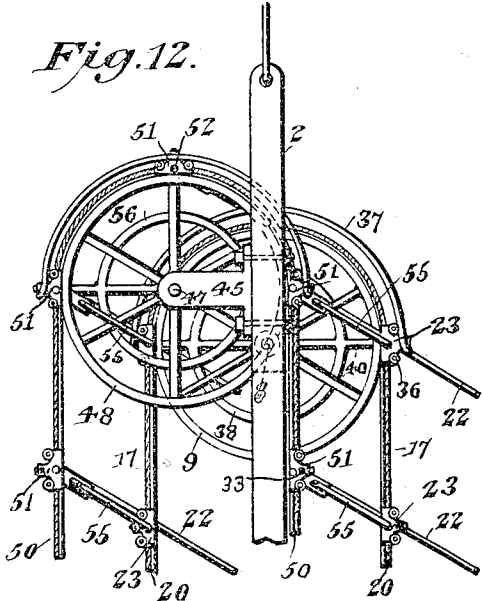
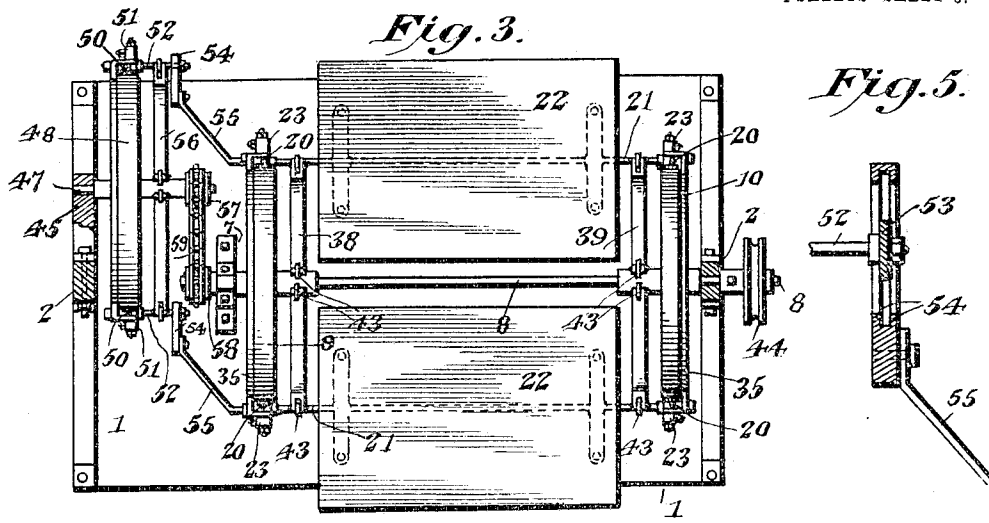

Arthur Symes, Inventor

Witnesses
James E. McCutcheon
Louis G. Julihn

B. G. Siggers
 Attorney

A. SYMES.
DISPLAY APPARATUS.
APPLICATION FILED MAY 19, 1904.

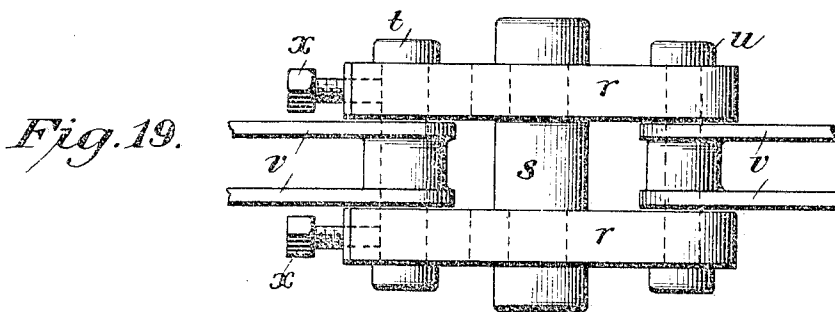
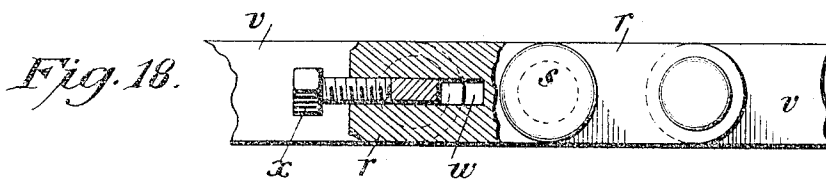
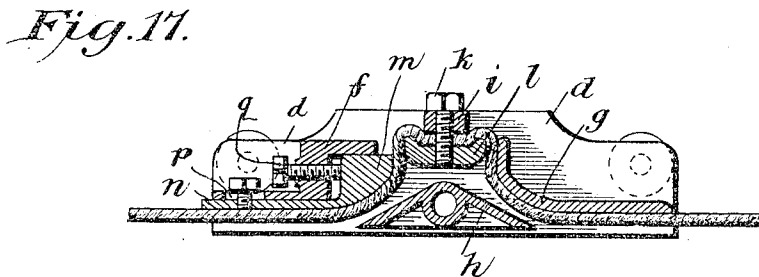
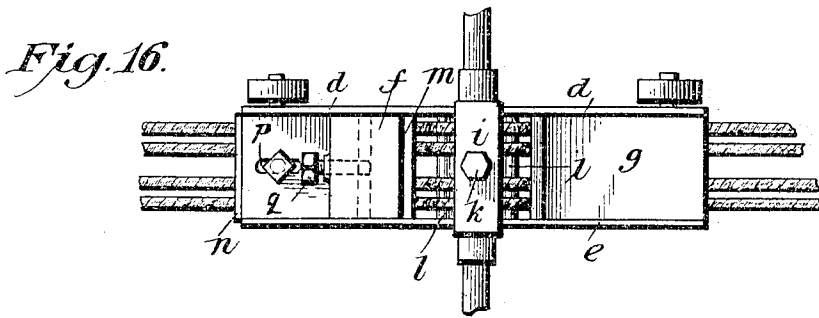

Arthur Symes, Inventor

Witnesses
 Jas. E. McClathran
 Lewis S. Julihn

By *E. G. Siggers*
 Attorney

UNITED STATES PATENT OFFICE.

ARTHUR SYMES, OF RIVER FALLS, WISCONSIN, ASSIGNOR TO AUTOMATIC SHELVING COMPANY, OF RIVER FALLS, WISCONSIN, A CORPORATION OF WISCONSIN.

DISPLAY APPARATUS.

SPECIFICATION forming part of Letters Patent No. 793,243, dated June 27, 1905.

Application filed May 19, 1904. Serial No. 208,754.

To all whom it may concern:

Be it known that I, ARTHUR SYMES, a citizen of the United States, residing at River Falls, in the county of Pierce and State of Wisconsin, have invented a new and useful Display Apparatus, of which the following is a specification.

This invention relates to display apparatus of that type which is characterized by endless elevating and conveying means especially adapted to exhibit a moving display, but capable of use in various other relations. Apparatus of this character ordinarily includes a suitable frame, within which are mounted sprockets supporting and driving a pair of endless carriers arranged to convey certain objects, which may be, for instance, a series of shelves associated with mechanism of some character for maintaining the shelves in proper position as they traverse a given path of movement. Many objections have been urged against this class of mechanism, among which may be mentioned the prohibitive frictional resistance opposed to their operation, the noise occasioned by the connections, particularly when sprockets and chains are utilized as carriers, the great increase of friction, and in some instances the total derangement of the apparatus occasioned by the unequal lengthening or stretching of the carriers after continued use and the lack of compensation for uneven or irregular movements or for lost motion. My aim is to overcome these various objections by causing endless carriers of novel construction to travel around independently-revoluble idlers and to be propelled in unison by drivers which engage suitable members—as, for instance, shelf or platform hangers—projecting from the carriers, the direct connection between the traveling structure and the drivers and the capability of the idlers for independent movement serving to insure proper action of the carriers without material friction even after the apparatus has been in use for a considerable period.

A further object of the invention is to associate with the traveling shelving an endless controller which, like the carriers, is mounted

to travel around idlers and is positively driven, so that proper movement in unison of the endless carriers and controller will be insured, notwithstanding uneven stretching or elongation of these elements in the course of use.

A still further object of the invention is to provide a novel connection between the shelf-hangers and the controller whereby the shelves will be constantly maintained in predetermined positions during their travel and whereby slight irregularities of movement will be compensated for.

Another object of the invention is to simplify the provision for adjusting the positions of the shelves with respect to the horizontal plane and to obviate the necessity for the employment of guides for maintaining the shelves in proper position during their travel.

Another object is to improve the connection between the endless carrying and controlling bands and the shelf-hangers and to provide simple and effective means constituting a part of said connection for taking up slack in the bands in order to compensate for the stretching or elongation thereof.

Still another object of the invention is to provide means for insuring proper substantially antifrictional movement of the bands around the idlers.

Finally, the object of the invention is to mount the entire apparatus in a strong light framework of skeleton form capable of being suspended from the ceiling, carried by wall-brackets, or incased in a cabinet and capable of being disposed vertically, horizontally, or at any desired inclination.

Other objects subordinate to those enumerated will appear during the course of the succeeding description of the illustrated structure.

In the accompanying drawings, Figure 1 is a front elevation of my apparatus complete. Fig. 2 is a side elevation thereof, a portion of the frame being broken away to show one mode of adjusting the controller. Fig. 3 is a detail plan view of the subject-matter of Fig. 1. Fig. 4 is a sectional elevation showing the manner in which the drivers engage the shelf-

hangers. Fig. 5 is a detail sectional view of the compensating connection between the controller and the shelf-hangers. Fig. 6 is an elevation of the subject-matter of Fig. 5. Fig. 7 is a detail sectional view of one of the hanger-brackets. Fig. 8 is a plan view of one of the brackets shown opposite the periphery of an idler. Fig. 9 is a side elevation of the subject-matter of Fig. 8. Fig. 10 is a sectional view thereof. Fig. 11 is a detail view of a portion of one of the driver-arms and a cooperating antifriction-roller. Fig. 12 is a side elevation of the upper portion of the apparatus, showing the controller in one of its adjusted positions. Fig. 13 is a modification showing the yoke of one of the driver-arms provided with antifrictional rollers. Fig. 14 is a modification in which drivers are located at opposite sides of each of the carrier-idlers. Fig. 15 is a sectional view of a modified form of hanger-bracket. Fig. 16 is a plan view of another modified form of hanger-bracket. Fig. 17 is a sectional view thereof. Fig. 18 is a sectional elevation of a hanger-bracket designed for use in connection with a sprocket-chain, and Fig. 19 is a plan view of the same subject-matter.

Like numerals of reference are employed to designate corresponding parts in the several figures of the drawings.

The entire structure is mounted in a light (preferably metallic) frame of skeleton form comprising a base 1, from which rise a pair of vertical side bars 2, connected by transverse frame-bars 3, 4, and 5 and stiffened by suitable diagonal braces 6. The frame also comprehends a third vertical bar 7, located somewhat nearer one side of the frame and terminating short of the ends thereof. The frame thus constructed may be suspended, carried by wall-brackets, or otherwise supported—as, for instance, in a show-window for the display of merchandise, &c., its open skeleton form preventing material obstruction of the light—or, if desired, the frame may be mounted in a suitable cabinet and in any event may be supported in a vertical, inclined, or horizontal position, as desired.

Adjacent to the upper end of the frame is mounted a driving-shaft 8, loosely supporting a pair of idlers 9 and 10. These idlers are in the form of comparatively large pulleys of any suitable construction and are arranged directly over a pair of similar idlers 11 and 12, mounted near the lower end of the frame upon short stud-shafts 13, extending inwardly from vertically-adjustable journal-boxes 14 and 15, mounted in the frame-bars 2 and 7, respectively, and shiftable by means of adjusting-screws 16. The several idlers 9, 10, 11, and 12 are all loosely mounted for independent rotary movement and are arranged in vertically-alined pairs for the reception of endless carriers 17 and 18, which preferably comprise belts in direct contact with the pe-

ripheries of the idlers and cables 20, cushioned by the belts. It should be distinctly understood, however, that the invention in its broader aspects is not limited to carriers of any specific construction, since it is obvious that chains, belts, or cables might be substituted for the combination belt and cable carriers illustrated in the drawings. The latter, however, I consider preferable.

The carriers 17 and 18 are connected by what may be termed "shelf-hangers" 21, preferably in the form of rods connected to both carriers and equipped with means for the attachment of shelves 22, disposed between the carriers, as shown in Figs. 1 and 3, and arranged to travel in an endless series as the carriers are propelled in unison by means to be described. The manner of connecting the shelf-hangers and carriers may be varied within wide limits; but by preference I employ what may be termed "hanger-brackets" 23, which are made to perform several other functions—that is to say, these brackets serve primarily as means for connecting the hangers and carriers. They also serve to clamp the cable and belt of each carrier together and are equipped with means whereby the cables may be drawn up or tightened after stretching or elongation thereof or loosened to avoid unnecessary friction in the bearings of the idlers. In Figs. 7, 8, 9, and 10 one of the hanger-brackets is clearly illustrated. Each bracket 23 is preferably in the form of a light casting closed at its outer side by a wall 24, from which extend flanges 25 and 26, defining a channel 27, the ends of which diverge from a dome 28. Through the channel thus formed a portion of the carrier is extended, the cable being drawn up into the dome by an adjustable tightener in the form of an eye 29, through which the cable is passed. The eye 29 is formed with a threaded shank 30, extended through the top wall of the dome and provided with the nut 31, by means of which the eye may be adjusted in order to draw up the cable or to slack the same when it is desired. In order to prevent the cable from being pulled through the eye by the weight imposed upon the carrier beyond either end of the bracket, the latter is additionally provided with a cable-lock in the form of a headed bolt 32, passed through one side wall of the dome 28 below the eye 29 and provided exterior to the dome with a nut 33, by means of which the head of the bolt may be adjusted to clamp the cable, and thus prevent accidental movement thereof. (See Fig. 7.) It should be noted at this point that the walls of the channel 27 are so formed that sharp corners, around which the cable or belt might be drawn and abraded, are avoided. Directly below the apex of the bottom flange 26 of each hanger-bracket is located a transverse cylindrical socket 34 for the reception of the shelf-hanger or rod, which

passes through the alined sockets of a pair of brackets secured to the respective carriers, as clearly shown in Figs. 1 and 3. In order to prevent sidewise slipping of the carriers, the outer edges of the peripheries of the idlers are formed with depressions or channels 35, into which extend the edges of the side walls 24 of the hanger-brackets, (see particularly Fig. 8.) and to insure the proper movement of the brackets around the pulleys the former are provided adjacent to their opposite ends with antifriction-rollers 36, working against the inner faces of segmental guides 37, concentric with the pulleys. (See Fig. 9.)

Having now seen the manner in which the carriers are mounted and connected and the means provided for the support of the shelves, it is in order to describe the mechanism whereby the carriers are positively driven to present the shelves in succession opposite a given point. Instead of applying power to the pulleys over which the carriers are led the carriers are driven positively by drivers 38 and 39, rigid with the shaft 8, and each comprising a series of connected driver-arms 40, provided with terminal yokes 41, arranged to engage the shelf-hangers or rods 21 at points adjacent to the carriers. (See Figs. 3 and 4.)

The antifrictional engagement of the yokes and hangers may be secured in a variety of ways. For instance, as shown in Fig. 11, antifriction-rollers 42 may be mounted upon the hangers for engagement with the yokes, or, if desired, the opposite ends of the yokes may be equipped with rollers 43 instead. (See Fig. 13.)

The shaft 8 may be driven in any suitable manner—as, for instance, by means of a mechanically, electrically, or manually operated motor geared to a power-pulley 44, fixed on the shaft beyond one side of the frame. It will now be obvious that when the driving-shaft is rotated the drivers 38 and 39, moving therewith, will engage the shelf-hangers or bars 21 and will cause the carriers to move in unison for the purpose of advancing the series of shelves carried by the hangers.

It appears proper at this point to direct particular attention to the special advantage accruing from the use of independent idlers for the carriers and driving mechanism operating independently of the idlers instead of through the same. It frequently happens that after continued use of an apparatus of this character one or the other of the carriers will stretch or elongate to some slight extent, and the shelf-supporting bars or hangers may therefore bear a slightly-abnormal relation to the yokes. If, therefore, the idlers were connected for movement in unison, one or the other of the carriers would have to slip, and this movement would be opposed by the friction induced between the extensive coacting surfaces of the wheel and the slipping carrier.

By the arrangement I employ, on the contrary,

any slight relative movement of the two carriers made necessary by irregularities of the character mentioned will be accommodated by the relative movement of the idlers, which will readily yield in order to compensate for the lost motion, material friction being thus avoided. Again, suppose instead of entering the yoke properly one of the hangers should assume the position indicated by the lower right-hand hanger in Fig. 4. Ordinarily this relation would speedily result in the derangement of the apparatus, whereas by the employment of independent idlers that one of them over which the carrier shown in Fig. 4 is passed will move forward slightly independently of the other idler to restore the proper relation between the yoke and the hanger. In short, I reduce the friction incidental to the operation of the machine to a minimum by providing independent mountings for both carriers and by providing additional means for positively driving the carriers in unison, but with a capability of such slight relative movement without slipping as will compensate for slight irregularities incidental to the continued use of the apparatus.

It is now in order to describe the means for retaining the shelves in predetermined positions as they traverse a prescribed path. Extended rearwardly from the left-hand side bar 2 of the frame are a pair of independently vertically adjustable bearing-brackets 45 and 46, from which extend stud-shafts 47 for the loose revoluble support of idlers 48 and 49, similar in all respects to the idlers which support the carriers. The shafts 47 are normally located in the horizontal planes in which the axes of the upper and lower carrier-idlers are located; but, as will be seen in Fig. 2, these shafts are offset to the rear, so that the upper and lower idlers 48 and 49 are out of alinement with the upper and lower idlers which support the carriers. The idlers 48 and 49 are designed for the support of an endless controller 50, identical in construction with the endless carriers 17 and 18 and likewise provided with hanger-brackets 51, similar to the brackets 23, by means of which laterally-disposed pins 52 are connected to the controller. These pins 52 are received by sliding boxes 53, mounted in the slotted vertically-disposed extremities 54 of angular arms 55, with which the hangers 21 are formed. (See Figs. 3 and 5.) The sliding boxes 53 constitute a yielding connection between the hangers and the controller, and this arrangement is still another feature for avoiding friction by accommodating or compensating for slight irregularities resulting from the uneven stretching or expansion of the controller with respect to the carriers.

The upper stud-shaft 47 constitutes the driving-shaft for the controller and, like the shaft 8, is equipped with a driver 56, constructed like the drivers 38 and 39, but designed to engage the pins 52 to positively drive the end-

less controller just as the endless carriers are driven by the drivers 38 and 39. Since the carriers and controller must all move in unison, it is preferable to drive the shaft 47 from the shaft 8, and in the present embodiment of the invention said shafts are provided with sprocket-wheels 57 and 58, geared together by a sprocket-chain 59. It will now be seen that the endless controller and the endless carriers are positively driven, that the controller and carriers are passed around independent idlers, and are driven in unison by driving mechanism which will compel the maintenance of the proper relations of the parts without, however, creating undue friction and binding in the event of slight maladjustment or derangement.

It is sometimes desirable to fix to the shafts objects to be displayed or to set the shelves at an angle in order that the display may be better observed from the front of the apparatus. If such an angular relation of the shelves is desired, it is simply necessary to adjust the controller vertically by shifting the bearing brackets 45 and 46 so as to move the axes of the controller idlers out of the horizontal planes in which the axes of the carrier idlers are located. Of course if extended adjustment is necessary the chain 59 is replaced by another of sufficient length. Such an adjustment is illustrated in Fig. 12, wherein it will be noted that the controller has been elevated, causing the angular or crank arms of the hangers to be swung and the shelves to be shifted to inclined positions. This same character of adjustment of the controller is useful when it is desired to set the apparatus at an inclination and to maintain the shelves in horizontal position, since it will be seen that by swinging the apparatus to the right from the position shown in Fig. 12 the shelves will be moved to horizontal positions, which will be maintained during the operation of the device.

Obviously the shelves may be omitted and replaced by any other provision for the support of the display. Similarly the shelf hangers or rods may be continuous, as shown, or may comprise sections secured to the opposite ends of the shelves. Attention may also be directed to the fact that while the separate driver for the controller is preferable it may in some instances be omitted, as the connections between the hangers and the controller will be sufficient for the operation of the controller. In Fig. 14 I have shown a possible variation of the described construction, the departure residing in the provision of drivers at both sides of each idler, as this arrangement may be desirable in some instances, and in Fig. 15 I have shown a modified form of hanger-bracket, in the dome of which are three angularly-related independently-adjustable screw-eyes *a*, *b*, and *c*, through which the cable is designed to pass. When this construction is employed, the cable may be se-

curely clamped by the intermediate eye *b* and either portion of the cable extending from opposite sides of said eye may be drawn up by adjusting either of the eyes *a* or *c*.

In Figs. 16 and 17 I have illustrated another form of hanger-bracket, which is particularly designed for use in an apparatus designed for heavy work and having its carriers made up of a number of strands or cables. This bracket comprises side flanges *d* and *e*, between which are located transverse connecting-webs *f*, *g*, and *h* and a transverse bar *i*. Through the bar *i* is passed a clamping-screw *k*, which carries a clamp *l*, arranged to clamp the cables comprising the carrier against the bar *i*, and thus effect a secure connection between the carrier and the bracket. The web *f* is of angular form, and with it is associated a tightener *m*, arranged to slide longitudinally of the bracket for the purpose of taking up slack in the carrier and provided with a tailpiece *n*, carrying a set-screw *n'*, accommodated in a slot *p* in the horizontal portion of the web *f*. The tightener or tightening-block *m* is adjusted by means of a tightening-screw *q*, passed through the vertical portion of the angular web *f*, as shown in Fig. 17, and having an exposed head by means of which the screw may be turned to move the block for the purpose of tightening the cables. The opposed faces of the tightening-block *m* and the web or flange *g* are curved to prevent the wearing of the cables, and the web *h* is located at the central portion of the bracket only in order to permit the cable to flex sufficiently to prevent sharp bends in the latter at the points where it extends radially from the idlers.

In Figs. 18 and 19 is shown a hanger-bracket adapted for use in this type of apparatus when sprocket-chains instead of cables or belts are employed as carriers. A pair of side plates *r* are connected by the sleeve *s*, which receives the hanger-rod, and at the opposite ends of these plates are retained transverse pintles or connectors *t* and *u*, which are engaged by links *v* of a sprocket-chain. One or both of the connectors, but preferably the connector *t*, is designed to have lateral movement for the purpose of taking up slack in the chain, such movement being accommodated by slots *w* in the plates *r*. For the purpose of moving the connector *t* to adjust the chain each of the plates *r* is equipped with a tightening-screw *x*, screwed into the end of the plate and bearing against the connector *t*. By turning up these screws the connector *t* may be shifted laterally to adjust the chain, as will be apparent.

Having described the preferred embodiment of my invention, I desire to direct particular attention to the fact that while the structure is designed for use as a display apparatus, since it avoids the many objections ordinarily urged against this type of devices, it is, nevertheless,

less, designed with special reference to its use for general elevating and conveying purposes, since its meritorious characteristics are in no way dependent upon the nature of the articles or objects conveyed. Furthermore, when used as a conveyer many variations of the illustrated arrangement may be resorted to. For instance, any desired number of sets of idlers may be variously located in order that conveyance may be effected in a number of different directions. For instance, the carriers by obvious rearrangement of the idlers may be made to travel in vertical, horizontal, and inclined paths. It is also apparent that various portions of the mechanism described are useful in this connection without reference to the various associated mechanisms which are grouped in the illustrated embodiment of the invention. For instance, under some conditions when there is no necessity for maintaining the shelves or platforms in horizontal position at all times the controller may be omitted, whether the apparatus is being used for display purposes or as an elevator or conveyer. Similarly the carriers, with their idlers, drivers, and brackets, may be utilized as a means for transmitting power, since this arrangement involves material novelty, aside from its utility in connection with conveying or display apparatus. The same may be said of the individual carriers and of the hanger-brackets. Finally, it should be noted that while the frame structure which has been described is desirable for the reasons stated the upper and lower idlers and drivers may be separately mounted in suitable frames located any desired distance apart.

It is thought that from the foregoing the construction, operation, and many advantages of my improved elevating, conveying, and display apparatus will be apparent to those skilled in the art without further description; but while the present embodiment of the invention is thought at this time to be preferable I desire to reserve the right to effect such changes, modifications, and variations of the illustrated structure as may fall fairly within the scope of the protection prayed.

What I claim as new is—

50 1. In an apparatus of the class described, the combination with an endless carrying device, including a pair of connected endless carriers capable of limited independent movement in the direction of travel, of idlers constituting separate, independent, relatively movable supports for the respective carriers, and driving mechanism independent of the idlers and engaging the endless carrying device to drive the same.

60 2. In an apparatus of the class described, the combination with a pair of endless carriers, independent idlers supporting the carriers, and connecting devices connecting the carriers at intervals, of operating mechanism including a

driver arranged to engage successive connecting devices to move the carriers. 65

3. In an apparatus of the class described, the combination with a pair of endless carriers, independent idlers supporting the carriers, and hangers arranged at intervals and connecting the carriers; of a rotary driver arranged to engage successive hangers to move the carriers in unison. 70

4. In an apparatus of the class described, the combination with a pair of endless carriers, independent idlers supporting the same, and hangers connecting the carriers; of a rotary driver engaging successive hangers to drive the carriers, shelves supported by the hangers, and controlling mechanism for maintaining the shelves in predetermined positions during the travel thereof. 75

5. In an apparatus of the class described, the combination with endless connected carriers, an endless controller, and independent idlers supporting the controller and carriers respectively; of hangers connecting the carriers and controller for movement in unison, and driving means engaging the hangers. 80

6. In an apparatus of the class described, the combination with endless carriers, and an endless controller; of independent idlers supporting the carriers and controller respectively, hangers connecting the carriers and having angular ends, pins extended from the controller and having loose engagement with the angular ends of the hangers, and driving means for the carriers. 85

7. In an apparatus of the class described, the combination with endless carriers, and an endless controller; of independent idlers for the carriers and controller respectively, hangers connecting the carriers and provided with angular ends, pins extended laterally from the controller and engaging the angular ends of the hangers, and driving mechanism engaging the hangers and pins respectively. 90

8. In an apparatus of the class described, the combination with endless carriers, and an endless controller; of hangers connecting the carriers and provided with angular ends, pins extended from the controller and engaging the angular ends of the hangers, and driving mechanism including a rotary driver engaging the hangers to drive the carriers, a second rotary driver engaging the pins to drive the controller, and gearing connecting said drivers. 95

9. In an apparatus of the class described, the combination with endless carriers, an endless controller, and independent idlers for the carriers and controller respectively; of means for effecting the relative adjustment of the idlers to take up the slack in the carriers and controller, hangers connected with the carriers and having angular slotted ends, pins extending into the slotted ends of the hangers from the controller, shelves carried by the hangers intermediate of the carriers, rotary driv- 100

ers geared to each other and arranged to engage the hangers and pins respectively, and means for rotating one of the drivers.

10. In an apparatus of the class described, the combination with a frame, idlers mounted therein, endless carriers passed around the idlers, and means for connecting the carriers for movement in unison; of adjustable journal-boxes mounted on the frame, stud-shafts extending from said boxes, idlers mounted on said shafts, a controller passed around the idlers, shelves mounted intermediate of the carriers and movable therewith, and means for operatively connecting the controller with the shelves to maintain the latter in proper position during their travel.

11. In an apparatus of the class described, the combination with a vertically-disposed frame, a pair of endless carriers, idlers supporting the same, and hangers connecting the carriers and having angular ends; of bearing-brackets extending rearwardly from the frame and adjustable lengthwise thereof, stud-shafts extending from said brackets, idlers mounted on the shafts, an endless controller passed around said idlers, means for connecting the controller to the angular ends of the hangers, and mechanism for driving the carriers and controller.

12. In an apparatus of the class described, the combination with a frame; of a pair of endless carriers disposed endwise thereof, an endless controller offset in rear of the frame and adjustable endwise thereof, hangers connecting the carriers and having angular ends in operative connection with the controller, and mechanism for driving the carriers and controller in unison.

13. In an apparatus of the class described, the combination with a pair of endless carriers, and independent idlers supporting the same; of a driving-shaft constituting a support for one pair of idlers, hangers connecting the carriers, driving mechanism including a driver fixed to the driving-shaft and having yokes disposed to engage the hangers, shelves supported by the hangers, and means for maintaining the shelves in proper position during their travel.

14. In an apparatus of the class described, the combination with a pair of endless carriers, and independent idlers supporting the same; of a driving-shaft constituting a support for a pair of said idlers, hangers connecting the carriers, shelves supported by the hangers, and a pair of drivers fixed to the driving-shaft adjacent to the idlers thereon, said drivers each comprising a series of radially-disposed arms having terminal yokes arranged to engage the hangers.

15. In an apparatus of the class described, the combination with a pair of endless carriers; of hangers connecting the carriers and provided with angular ends, boxes slidably mount-

ed in said ends, an endless controller having laterally-disposed pins extended into the sliding boxes, and mechanism for driving the carriers and controller.

16. In an apparatus of the class described, the combination with a pair of endless carriers; of hanger-brackets secured to the carriers and having transverse sockets, hangers fitted into the sockets of the brackets and connected to the carriers, and shelves supported by the hangers.

17. In an apparatus of the class described, the combination with a flexible carrier; of a hanger-bracket provided with a channel for the carrier and with a socket for the reception of a hanger.

18. In an apparatus of the character described, the combination with a hanger-bracket provided with a longitudinally-disposed channel; and a transversely-disposed socket; of a flexible carrier extended through the channel, and adjustable means for connecting the bracket and the carrier.

19. In an apparatus of the class described, the combination with a hanger-bracket provided with a longitudinal channel, a dome, and a transverse hanger-socket; of a flexible carrier passed through the channel in the bracket, and adjustable means for drawing a portion of the carrier into the dome of the bracket.

20. In an apparatus of the class described, the combination with a hanger-bracket provided with a longitudinal channel, a dome, and a transverse hanger-socket; of a flexible carrier passed through the channel in the bracket, adjustable means for drawing a portion of the carrier into the dome of the bracket, and means for securing the carrier and bracket against relative movement.

21. In an apparatus of the class described, the combination with a hanger-bracket provided with a longitudinal channel, a dome communicating with the channel midway of its ends, and a transverse hanger-socket located at the side of the channel opposite the dome; of an endless carrier passed through the channel of the bracket, and means located within the dome for adjustably retaining the carrier.

22. In an apparatus of the class described, the combination with a hanger-bracket provided with a longitudinal channel, a dome communicating with the channel midway of its ends, and a transverse hanger-socket located at the side of the channel opposite the dome; of an endless carrier passed through the channel of the bracket, and an adjustable screw-eye located in the dome and engaged by the carrier.

23. In an apparatus of the character described, the combination with a hanger-bracket provided with a longitudinal channel, a dome communicating with the channel midway of its ends, and a transverse hanger-socket located at the side of the channel opposite the

dome; of an endless carrier passed through the channel of the bracket, an adjustable screw-eye located in the dome and engaged by the carrier, and a locking device in the form of a headed bolt passed transversely through the dome and arranged to clamp the carrier against one wall thereof.

24. In an apparatus of the class described, the combination with an idler, and a flexible carrier; of a hanger-bracket connected to the carrier and provided with a hanger-socket, an arcuate guard concentric with the idler, and rollers mounted on the bracket and arranged to engage the guard.

25. In an apparatus of the class described, the combination with a flexible carrier, of a

hanger-bracket, and means associated with said bracket for adjusting the carrier.

26. In an apparatus of the class described, the combination with a flexible carrier, of a hanger-bracket, means associated with the bracket for securing the latter to the carrier, and means also associated with the bracket for taking up slack in the carrier.

In testimony that I claim the foregoing as my own I have hereto affixed my signature in the presence of two witnesses.

ARTHUR SYMES.

Witnesses:

WARREN P. KNOWLES,
BERTRAM SYMES.