



US00D832494S

(12) **United States Design Patent**
Antony et al.

(10) **Patent No.:** **US D832,494 S**

(45) **Date of Patent:** **** Oct. 30, 2018**

- (54) **LIGHTING MODULE HEATSINK**
- (71) Applicant: **Flex Ltd.**, Singapore (SG)
- (72) Inventors: **Ashish Antony**, Anna, TX (US); **Kevin Emr**, Dallas, TX (US); **Jordon Musser**, Dallas, TX (US)
- (73) Assignee: **Flex Ltd.**, Singapore (SG)
- (**) Term: **15 Years**
- (21) Appl. No.: **29/613,359**
- (22) Filed: **Aug. 9, 2017**
- (51) **LOC (11) Cl.** **26-05**
- (52) **U.S. Cl.**
USPC **D26/138**
- (58) **Field of Classification Search**
USPC D25/119, 164; D26/28, 30, 31, 118, 2, D26/73, 74, 75, 76, 78, 122, 121, 138, D26/136, 137, 139-145, 155, 71, 60, 68, D26/113
CPC F21V 31/03; F21V 7/0083; F21V 29/004; B60Q 1/04; B60Q 1/26
See application file for complete search history.

- 2,606,998 A 8/1952 Winkler et al.
- D173,255 S 10/1954 Brooks et al.
- 2,715,449 A 8/1955 Lemmerman et al.
- D188,436 S 7/1960 Budke et al.
- 3,009,055 A 11/1961 Franzese
(Continued)

OTHER PUBLICATIONS

Flex Essentials Series Sell Specification Sheets, Published Jun. 2016 (28 pages).

(Continued)

Primary Examiner — Mark A Goodwin
Assistant Examiner — Benjamin M Weeks
(74) *Attorney, Agent, or Firm* — Carter, DeLuca, Farrell & Schmidt, LLP

(57) **CLAIM**

The ornamental design for a lighting module heatsink, as shown and described.

DESCRIPTION

FIG. 1 is a perspective view of a lighting module heatsink in accordance with the present design;
FIG. 2 is a front view of the lighting module heatsink of FIG. 1, shown increased in scale for clarity;
FIG. 3 is a rear view of the lighting module heatsink of FIG. 1, shown increased in scale for clarity;
FIG. 4 is a left, side view of the lighting module heatsink of FIG. 1;
FIG. 5 is a right, side view of the lighting module heatsink of FIG. 1;
FIG. 6 is a top view of the lighting module heatsink of FIG. 1; and,
FIG. 7 is a bottom view of the lighting module heatsink of FIG. 1.
The broken lines provided in the drawings form no part of the claimed design.

1 Claim, 3 Drawing Sheets

(56) **References Cited**

U.S. PATENT DOCUMENTS

D120,548 S	5/1940	Guth
D122,145 S	8/1940	MacCarthy
D122,887 S	10/1940	Beals
D123,067 S	10/1940	Rubinstein
D123,887 S	12/1940	Koehler
D127,398 S	5/1941	Jordan
D128,961 S	8/1941	Hrabak
D129,726 S	9/1941	Scribner
D130,570 S	12/1941	Borkland
2,312,617 A	3/1943	Beck
D139,669 S	12/1944	Lippincott
D142,126 S	8/1945	Sabatini
D150,735 S	8/1948	Schwartz et al.
D151,575 S	10/1948	Winkler et al.

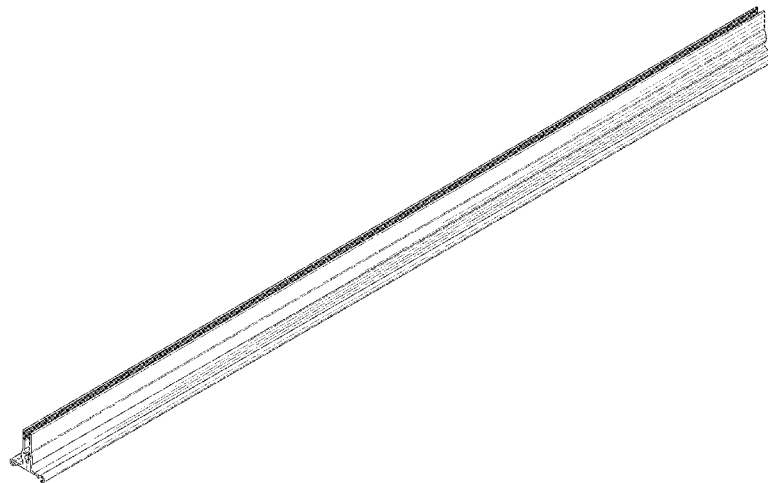

(56)

References Cited

U.S. PATENT DOCUMENTS

3,209,142	A	9/1965	Michel et al.	7,786,375	B2	8/2010	Swanson et al.
D208,491	S	9/1967	Brooks	7,804,022	B2	9/2010	De Ceuster
D255,851	S	7/1980	Crane	7,807,918	B2	10/2010	Shingleton et al.
D291,598	S	8/1987	Elkerbout	7,812,250	B2	10/2010	Smith
4,726,781	A	2/1988	Bernhart et al.	7,820,475	B2	10/2010	De Ceuster et al.
D379,530	S *	5/1997	Leonelli D25/124	7,824,070	B2	11/2010	Higley et al.
6,061,978	A	5/2000	Dinwoodie et al.	7,838,062	B2	11/2010	Cousins et al.
6,076,943	A	6/2000	Lassovsky	7,851,698	B2	12/2010	De Ceuster et al.
6,274,402	B1	8/2001	Verlinden et al.	D632,418	S	2/2011	Bisberg et al.
6,295,818	B1	10/2001	Ansley et al.	7,883,343	B1	2/2011	Mulligan et al.
6,313,395	B1	11/2001	Crane et al.	7,888,587	B2	2/2011	Shingleton et al.
6,333,457	B1	12/2001	Mulligan et al.	7,888,588	B2	2/2011	Shingleton
6,337,283	B1	1/2002	Verlinden et al.	7,893,409	B1	2/2011	Cousins
6,387,726	B1	5/2002	Verlinden et al.	D634,063	S *	3/2011	Peifer D26/138
6,423,568	B1	7/2002	Verlinden et al.	7,897,867	B1	3/2011	Mulligan et al.
6,495,750	B1	12/2002	Dinwoodie	7,945,413	B2	5/2011	Krein
6,501,013	B1	12/2002	Dinwoodie	7,956,281	B2	6/2011	O'Brien et al.
D472,007	S	3/2003	Weitgasser	7,958,886	B2	6/2011	Barsun et al.
6,536,326	B2	3/2003	Unger et al.	7,982,434	B2	7/2011	Kimball et al.
6,570,084	B2	5/2003	Dinwoodie	7,994,657	B2	8/2011	Kimball et al.
6,684,637	B2	2/2004	Beale	8,004,865	B2	8/2011	Krein et al.
6,722,357	B2	4/2004	Shingleton	8,008,575	B2	8/2011	De Ceuster et al.
D489,830	S *	5/2004	Barnett D25/119	D644,609	S	9/2011	Marroquin
6,745,687	B1	6/2004	Kaminar	D644,610	S	9/2011	Marroquin
D492,809	S	7/2004	Weitgasser	8,029,683	B2	10/2011	Rose et al.
6,809,251	B2	10/2004	Dinwoodie	D649,687	S *	11/2011	Trzesniowski D26/138
6,809,253	B2	10/2004	Dinwoodie	8,061,091	B2	11/2011	Botkin et al.
6,883,290	B2	4/2005	Dinwoodie	8,062,693	B2	11/2011	Cousins
D510,315	S	10/2005	Shugar et al.	8,065,844	B2	11/2011	Botkin et al.
D511,576	S	11/2005	Shingleton et al.	8,080,819	B2	12/2011	Mueller et al.
D516,017	S	2/2006	Mascolo	D652,985	S *	1/2012	Trzesniowski D26/138
6,998,288	B1	2/2006	Smith et al.	8,101,849	B2	1/2012	Almy et al.
D519,444	S	4/2006	Mascolo	8,108,081	B2	1/2012	Lenox
D521,172	S	5/2006	Chen	8,120,933	B2	2/2012	Chapman et al.
7,072,096	B2	7/2006	Holman et al.	8,134,217	B2	3/2012	Rim et al.
7,135,350	B1	11/2006	Smith et al.	8,148,627	B2	4/2012	Rose et al.
7,140,742	B2	11/2006	Pohlert et al.	8,158,877	B2	4/2012	Klein et al.
7,144,214	B2	12/2006	Kinpara et al.	8,163,638	B2	4/2012	De Ceuster et al.
7,155,870	B2	1/2007	Almy	8,172,989	B2	5/2012	Pass
7,172,184	B2	2/2007	Pavani et al.	8,174,856	B2	5/2012	Chapman
7,178,295	B2	2/2007	Dinwoodie	8,188,363	B2	5/2012	Xavier et al.
7,178,941	B2	2/2007	Roberge et al.	D662,256	S *	6/2012	Klu D26/138
7,297,865	B2	11/2007	Terao et al.	D662,653	S *	6/2012	Hochman D26/138
7,297,866	B2	11/2007	Aschenbrenner	8,192,048	B2	6/2012	Kristoffersen et al.
D562,225	S	2/2008	Almy et al.	8,192,056	B2	6/2012	Villard
7,328,534	B2	2/2008	Dinwoodie	8,193,788	B2	6/2012	Chapman
RE40,158	E	3/2008	Weitgasser	8,198,528	B2	6/2012	Luan et al.
D564,958	S	3/2008	Almy et al.	8,206,009	B2	6/2012	Tickner et al.
7,339,110	B1	3/2008	Mulligan et al.	8,207,444	B2	6/2012	Cousins
D565,505	S	4/2008	Shugar et al.	8,207,637	B2	6/2012	Marroquin et al.
7,388,147	B2	6/2008	Mulligan et al.	8,211,731	B2	7/2012	Harley et al.
7,390,961	B2	6/2008	Aschenbrenner et al.	8,215,071	B2	7/2012	Lenox
7,435,134	B2	10/2008	Lenox	8,220,210	B2	7/2012	Botkin et al.
7,438,432	B2	10/2008	Yaphe et al.	8,221,600	B2	7/2012	Ganti
7,455,787	B2	11/2008	Rose et al.	8,221,601	B2	7/2012	Chen et al.
7,468,485	B1	12/2008	Swanson	8,222,516	B2	7/2012	Cousins
D586,737	S	2/2009	Shugar et al.	8,227,942	B2	7/2012	Marroquin et al.
D592,785	S	5/2009	Bisberg et al.	8,230,850	B2	7/2012	Barsun et al.
7,530,830	B1	5/2009	Lenox	D665,123	S *	8/2012	Douglas D26/138
7,554,030	B2	6/2009	Shingleton	8,234,824	B2	8/2012	Botkin et al.
7,554,031	B2	6/2009	Swanson et al.	8,242,354	B2	8/2012	Smith
7,557,292	B2	7/2009	Shingleton et al.	D666,974	S	9/2012	Marroquin et al.
7,622,912	B1	11/2009	Adams et al.	8,258,395	B2	9/2012	Wares
7,633,006	B1	12/2009	Swanson	8,263,899	B2	9/2012	Harley et al.
7,648,257	B2	1/2010	Villard	8,276,329	B2	10/2012	Lenox
7,663,342	B2	2/2010	Kimball et al.	8,279,642	B2	10/2012	Chapman et al.
7,670,638	B2	3/2010	Luan et al.	8,279,649	B2	10/2012	Esrarn et al.
7,681,090	B2	3/2010	Kimball et al.	8,284,574	B2	10/2012	Chapman et al.
7,705,237	B2	4/2010	Swanson	8,291,654	B2	10/2012	Botkin et al.
7,708,578	B1	5/2010	Lenox	8,294,022	B2	10/2012	Lenox
7,718,888	B2	5/2010	Cousins	8,304,644	B2	11/2012	Wares et al.
7,737,357	B2	6/2010	Cousins	8,308,324	B2	11/2012	Van Horn et al.
7,755,916	B2	7/2010	Krein et al.	8,317,987	B2	11/2012	Abas et al.
7,774,998	B2	8/2010	Aschenbrenner	D673,320	S	12/2012	Guercio et al.
7,780,472	B2	8/2010	Lenox	8,322,300	B2	12/2012	Pavani et al.
				8,324,015	B2	12/2012	Harley et al.
				8,325,499	B2	12/2012	Krein et al.
				8,334,161	B2	12/2012	Dennis et al.
				8,334,489	B2	12/2012	Beardsworth et al.

(56)

References Cited

U.S. PATENT DOCUMENTS

8,336,539	B2	12/2012	Linderman et al.	8,709,851	B2	4/2014	Dennis et al.
8,350,411	B2	1/2013	Kimball et al.	8,712,745	B2	4/2014	Wayne et al.
8,350,417	B1	1/2013	Dooley et al.	8,716,596	B1	5/2014	Swanson
8,352,220	B2	1/2013	Wayne et al.	8,737,093	B1	5/2014	Baker et al.
8,360,601	B2	1/2013	Muschaweck et al.	8,737,100	B2	5/2014	Chapman et al.
8,377,738	B2	2/2013	Dennis et al.	8,744,791	B1	6/2014	Kraft et al.
8,378,706	B2	2/2013	Kinyon et al.	8,748,736	B2	6/2014	Luan et al.
8,393,707	B2	3/2013	Cudzinovic et al.	8,754,627	B1	6/2014	Le
8,399,287	B1	3/2013	Mulligan et al.	8,757,567	B2	6/2014	Ciasulli et al.
8,402,703	B2	3/2013	Brandt et al.	8,763,316	B2	7/2014	Concho et al.
8,409,902	B1	4/2013	Harley et al.	8,767,421	B2	7/2014	Chapman
8,409,911	B2	4/2013	Cousins	8,772,894	B2	7/2014	Smith
8,409,912	B2	4/2013	de Ceuster et al.	8,774,007	B2	7/2014	Hussain et al.
8,423,312	B2	4/2013	Krein	8,776,781	B2	7/2014	Meydbray
8,424,255	B2	4/2013	Lenox et al.	8,778,787	B2	7/2014	Manning
8,426,974	B2	4/2013	Linderman et al.	8,785,233	B2	7/2014	Loscutoff et al.
8,448,391	B2	5/2013	Botkin et al.	8,785,236	B2	7/2014	Harley et al.
8,448,652	B2	5/2013	Almy et al.	8,785,830	B2	7/2014	Judkins
8,449,238	B2	5/2013	Mulligan et al.	8,786,095	B2	7/2014	Linderman et al.
8,450,134	B2	5/2013	De Ceuster et al.	8,790,957	B2	7/2014	Li et al.
8,450,985	B2	5/2013	Gray et al.	8,793,942	B2	8/2014	Almy et al.
8,451,638	B2	5/2013	Chapman et al.	8,796,061	B2	8/2014	Bunea
8,455,806	B2	6/2013	Judkins	8,796,535	B2	8/2014	Linderman
8,456,876	B2	6/2013	Chapman	8,796,884	B2	8/2014	Naiknaware et al.
8,460,963	B2	6/2013	Smith	8,802,486	B2	8/2014	Li et al.
8,461,813	B2	6/2013	Chapman	8,809,671	B2	8/2014	Linderman et al.
8,462,518	B2	6/2013	Marroquin et al.	8,815,631	B2	8/2014	Cousins
8,482,947	B2	7/2013	Chapman et al.	8,817,510	B2	8/2014	Esrasm et al.
8,486,746	B2	7/2013	Rim et al.	8,818,924	B2	8/2014	Wayne et al.
8,492,253	B2	7/2013	Manning	8,822,257	B2	9/2014	Rim et al.
8,503,200	B2	8/2013	Chapman et al.	8,822,262	B2	9/2014	Loscutoff et al.
8,508,964	B2	8/2013	Gray et al.	8,822,812	B2	9/2014	Wares
8,516,754	B2	8/2013	Botkin et al.	8,823,356	B2	9/2014	Chapman
8,519,729	B2	8/2013	Capulong et al.	8,824,178	B1	9/2014	Baker et al.
D690,453	S	9/2013	Guercio et al.	8,839,784	B2	9/2014	Wares et al.
8,528,366	B2	9/2013	Berrada Sounni et al.	8,842,454	B2	9/2014	Johnson et al.
8,530,990	B2	9/2013	Linderman et al.	8,859,933	B2	10/2014	Harley et al.
8,534,007	B2	9/2013	Almy et al.	8,860,162	B2	10/2014	Linderman et al.
8,546,681	B2	10/2013	Wares et al.	8,860,242	B1	10/2014	Pruett et al.
8,548,637	B2	10/2013	Lenox	8,877,617	B2	11/2014	Wong et al.
8,552,288	B2	10/2013	Xavier	8,878,053	B2	11/2014	Cousins
8,557,093	B2	10/2013	Cousins et al.	8,881,415	B2	11/2014	Barton
8,558,101	B2	10/2013	Mascolo et al.	8,883,247	B2	11/2014	Cousins et al.
8,563,849	B2	10/2013	Johnston et al.	8,893,713	B2	11/2014	Wares et al.
8,567,134	B1	10/2013	Grushkowitz et al.	8,901,010	B2	12/2014	Westerberg et al.
8,572,836	B2	11/2013	Lenox	8,904,717	B2	12/2014	Lenox
8,580,599	B2	11/2013	Rim et al.	8,912,038	B2	12/2014	Li et al.
8,584,406	B2	11/2013	Wexler et al.	8,922,062	B2	12/2014	Johnson et al.
8,584,667	B2	11/2013	Linderman et al.	8,922,185	B2	12/2014	Ehlmann et al.
8,586,397	B2	11/2013	Wu et al.	8,929,094	B2	1/2015	Marroquin et al.
8,586,403	B2	11/2013	Harley et al.	8,943,765	B2	2/2015	Danning et al.
8,597,970	B2	12/2013	Cousins et al.	8,945,978	B2	2/2015	Behnke
8,599,587	B2	12/2013	Chapman et al.	8,946,541	B2	2/2015	Wares et al.
8,604,404	B1	12/2013	Linderman	8,955,267	B2	2/2015	Wexler et al.
8,609,977	B2	12/2013	Jones et al.	8,956,018	B2	2/2015	Deshpande et al.
8,611,107	B2	12/2013	Chapman et al.	8,962,082	B2	2/2015	Pavani et al.
8,615,941	B2	12/2013	Botkin et al.	8,962,373	B2	2/2015	Cousins et al.
8,624,561	B1	1/2014	Slavin	8,963,185	B2	2/2015	Cousins
8,624,621	B2	1/2014	Capulong et al.	8,963,375	B2	2/2015	DeGraaff
8,629,383	B2	1/2014	Beardsworth et al.	8,964,401	B2	2/2015	Escamilla et al.
8,630,077	B2	1/2014	Johnston et al.	8,975,175	B1	3/2015	Pass
8,634,216	B2	1/2014	Chapman	8,975,717	B2	3/2015	Smith
8,636,198	B1	1/2014	Linderman et al.	8,988,096	B1	3/2015	Naiknaware
8,647,911	B2	2/2014	Smith	8,991,682	B2	3/2015	Linderman et al.
8,650,813	B2	2/2014	Botkin et al.	8,992,803	B2	3/2015	Loscutoff et al.
8,656,660	B2	2/2014	Danning	9,010,041	B2	4/2015	Danning
8,658,454	B2	2/2014	Pass et al.	9,018,033	B2	4/2015	Wu
D700,991	S	3/2014	Johnson et al.	9,018,516	B2	4/2015	Shepherd et al.
8,661,753	B2	3/2014	Lenox	9,020,653	B2	4/2015	Lenox
8,662,008	B2	3/2014	Abas et al.	9,029,689	B2	5/2015	Phu et al.
8,664,519	B2	3/2014	De Ceuster et al.	9,035,167	B2	5/2015	Swanson et al.
8,679,889	B2	3/2014	Cousins et al.	9,035,168	B2	5/2015	Barton
D703,858	S	4/2014	Miller	9,035,172	B2	5/2015	Kim et al.
8,683,761	B2	4/2014	Danning	9,035,633	B1	5/2015	Slavin et al.
8,692,111	B2	4/2014	Kim et al.	9,038,421	B2	5/2015	Berrada Sounni et al.
				9,048,740	B2	6/2015	Gray et al.
				9,054,255	B2	6/2015	Swanson et al.
				9,059,604	B2	6/2015	Johnson
				9,062,854	B2	6/2015	Livesay et al.

(56)

References Cited

U.S. PATENT DOCUMENTS

9,065,354	B2	6/2015	Chapman et al.	9,316,417	B2	4/2016	Danning
9,070,804	B2	6/2015	Cousins	9,322,437	B2	4/2016	Agullo
9,077,202	B1	7/2015	Baker	9,322,963	B2	4/2016	Linderman et al.
9,082,925	B2	7/2015	Solomon et al.	9,326,339	B2	4/2016	Nieberlein et al.
9,083,121	B2	7/2015	DeGraaff et al.	9,328,427	B2	5/2016	Behnke
9,087,939	B2	7/2015	Harley et al.	9,329,322	B2	5/2016	Yamada et al.
9,093,919	B2	7/2015	Chapman et al.	9,337,369	B2	5/2016	Smith
9,101,082	B1	8/2015	Dorenkamp et al.	9,342,088	B2	5/2016	Batten et al.
9,112,066	B2	8/2015	Dennis et al.	9,347,619	B2	5/2016	Schupple et al.
9,112,097	B2	8/2015	Tu	9,353,970	B2	5/2016	Linderman et al.
9,116,202	B2	8/2015	Capulong et al.	9,362,427	B2	6/2016	Sewell et al.
9,136,710	B1	9/2015	Baker et al.	D776,854	S *	1/2017	Baumeister D26/76
9,142,696	B2	9/2015	Loscutoff et al.	D782,106	S *	3/2017	Porciatti D26/138
9,147,795	B2	9/2015	Li et al.	D791,400	S *	7/2017	Sonneman D26/138
9,153,712	B2	10/2015	Zhu	D806,937	S *	1/2018	Klus D26/138
9,159,521	B1	10/2015	Chen et al.	D817,534	S *	5/2018	Noh D26/76
9,160,408	B2	10/2015	Krohne et al.	2002/0181229	A1	12/2002	Wei
9,166,079	B2	10/2015	Manning	2011/0312119	A1	12/2011	Rose et al.
9,178,104	B2	11/2015	Moors et al.	2012/0134189	A1	5/2012	Krein
9,184,324	B2	11/2015	Wares et al.	2012/0180845	A1	7/2012	Cole et al.
9,184,327	B2	11/2015	Rose et al.	2012/0192925	A1	8/2012	Grushkowitz et al.
9,185,759	B2	11/2015	Nieberlein et al.	2012/0216852	A1	8/2012	Almy et al.
9,186,741	B2	11/2015	Kumaria et al.	2013/0000694	A1	1/2013	Bunea et al.
9,190,839	B2	11/2015	Johnston et al.	2013/0106196	A1	5/2013	Johnson et al.
9,193,014	B2	11/2015	Danning	2013/0239947	A1	9/2013	Almy et al.
9,196,758	B2	11/2015	Rim et al.	2013/0255749	A1	10/2013	Kinyon et al.
D744,684	S	12/2015	Guercio et al.	2013/0305787	A1	11/2013	Berrada Sounni et al.
D744,690	S	12/2015	Boyer et al.	2013/0340379	A1	12/2013	Danning
9,202,960	B2	12/2015	Luan et al.	2013/0340380	A1	12/2013	Danning
9,212,808	B2	12/2015	Higley et al.	2014/0000187	A1	1/2014	Botkin et al.
9,217,206	B2	12/2015	Behnke et al.	2014/0000695	A1	1/2014	Stone
9,219,173	B2	12/2015	Swanson et al.	2014/0000705	A1	1/2014	Sounni et al.
9,222,193	B2	12/2015	Abas et al.	2014/0014499	A1	1/2014	Cousins et al.
9,224,902	B2	12/2015	Swanson	2014/0034111	A1	2/2014	Bunea et al.
9,225,256	B2	12/2015	Chapman et al.	2014/0034122	A1	2/2014	Cousins
9,225,285	B2	12/2015	Peurach et al.	2014/0034455	A1	2/2014	Mulligan et al.
9,231,129	B2	1/2016	Harley et al.	2014/0036563	A1	2/2014	Chapman et al.
9,231,145	B2	1/2016	Smith	2014/0048119	A1	2/2014	Johnston et al.
9,239,153	B2	1/2016	Goodman et al.	2014/0090637	A1	4/2014	Grushkowitz
9,240,682	B2	1/2016	Sivakumar et al.	2014/0090638	A1	4/2014	Grushkowitz
9,243,818	B2	1/2016	Shugar et al.	2014/0090701	A1	4/2014	Rim et al.
9,246,037	B2	1/2016	Linderman	2014/0102505	A1	4/2014	Lenox
9,246,046	B1	1/2016	Harrington et al.	2014/0102512	A1	4/2014	Jones et al.
9,249,044	B2	2/2016	Judkins et al.	2014/0116495	A1	5/2014	Kim et al.
9,249,523	B2	2/2016	Rim	2014/0133197	A1	5/2014	Chapman
9,252,314	B2	2/2016	Wares et al.	2014/0150846	A1	6/2014	Beardsworth et al.
9,252,319	B2	2/2016	Loscutoff et al.	2014/0174905	A1	6/2014	Landry
9,253,935	B2	2/2016	Morris et al.	2014/0182661	A1	7/2014	Kinyon
9,257,575	B1	2/2016	Pass et al.	2014/0190561	A1	7/2014	De Ceuster et al.
9,257,847	B2	2/2016	Johnson et al.	2014/0202492	A1	7/2014	Grossman et al.
9,263,183	B2	2/2016	Chapman et al.	2014/0238470	A1	8/2014	Ciasulli et al.
9,263,601	B2	2/2016	Wu et al.	2014/0261626	A1	9/2014	Ripoll Agullo
9,263,602	B2	2/2016	Harley et al.	2014/0268908	A1	9/2014	Zhou et al.
9,263,622	B2	2/2016	Pass et al.	2014/0290715	A1	10/2014	Meydbray
9,263,625	B2	2/2016	Smith et al.	2014/0291852	A1	10/2014	Linderman et al.
9,263,895	B2	2/2016	Naiknaware et al.	2014/0305501	A1	10/2014	Li et al.
9,266,468	B2	2/2016	Mizushiro et al.	2014/0306092	A1	10/2014	Judkins
9,267,649	B2	2/2016	Janik et al.	2014/0311054	A1	10/2014	Concho et al.
D751,976	S	3/2016	Mackler et al.	2014/0322855	A1	10/2014	Bunea
9,273,845	B2	3/2016	Eom et al.	2014/0345688	A1	11/2014	Cousins
9,276,635	B2	3/2016	Rothblum et al.	2014/0352761	A1	12/2014	Linderman et al.
9,279,457	B2	3/2016	Grushkowitz	2014/0373910	A1	12/2014	Luan et al.
9,279,569	B2	3/2016	Lamonato et al.	2015/0000724	A1	1/2015	Pass et al.
9,281,419	B2	3/2016	Klein et al.	2015/0004737	A1	1/2015	Harley
9,281,429	B2	3/2016	Xavier et al.	2015/0020867	A1	1/2015	Linderman et al.
9,281,431	B2	3/2016	Linderman	2015/0040944	A1	2/2015	Dinwoodie et al.
9,285,081	B2	3/2016	Douglas et al.	2015/0047690	A1	2/2015	Shen et al.
9,293,624	B2	3/2016	Cudzynovic et al.	2015/0053248	A1	2/2015	Rim et al.
9,300,224	B2	3/2016	Johnson et al.	2015/0083215	A1	3/2015	Cousins
D754,064	S	4/2016	Mackler et al.	2015/0090328	A1	4/2015	Smith
9,303,285	B2	4/2016	Piazza et al.	2015/0090329	A1	4/2015	Pass
9,306,085	B2	4/2016	Westerberg et al.	2015/0108692	A1	4/2015	Harley et al.
9,312,042	B2	4/2016	Sewell et al.	2015/0117067	A1	4/2015	Naiknaware et al.
9,312,406	B2	4/2016	Loscutoff et al.	2015/0122305	A1	5/2015	Marroquin et al.
9,312,425	B2	4/2016	Kim et al.	2015/0128437	A1	5/2015	Barton
				2015/0144197	A1	5/2015	Cousins et al.
				2015/0146315	A1	5/2015	Wares et al.
				2015/0155819	A1	6/2015	Wexler et al.
				2015/0163074	A1	6/2015	Pruett et al.

(56)

References Cited

U.S. PATENT DOCUMENTS

2015/0180238	A1	6/2015	DeGraaff	2016/0020827	A1	1/2016	Krohne et al.
2015/0180404	A1	6/2015	Braunstein et al.	2016/0027953	A1	1/2016	Moors et al.
2015/0194539	A1	7/2015	Shepherd et al.	2016/0028345	A1	1/2016	Wares et al.
2015/0194927	A1	7/2015	Naiknaware	2016/0035908	A1	2/2016	Rose et al.
2015/0206988	A1	7/2015	Loscutoff et al.	2016/0036380	A1	2/2016	Johnston et al.
2015/0212535	A1	7/2015	Ehlmann et al.	2016/0043267	A1	2/2016	Rim et al.
2015/0214744	A1	7/2015	Lenox	2016/0043684	A1	2/2016	Harif
2015/0222225	A1	8/2015	Danning	2016/0064576	A1	3/2016	Luan et al.
2015/0229221	A1	8/2015	Gray et al.	2016/0065119	A1	3/2016	Danning
2015/0249405	A1	9/2015	Chapman et al.	2016/0071991	A1	3/2016	Smith
2015/0249423	A1	9/2015	Braunstein et al.	2016/0071996	A1	3/2016	Swanson et al.
2015/0263200	A1	9/2015	Dennis et al.	2016/0071999	A1	3/2016	Loscutoff et al.
2015/0270803	A1	9/2015	Barton	2016/0079450	A1	3/2016	Harley et al.
2015/0280038	A1	10/2015	Sethi et al.	2016/0079911	A1	3/2016	Rose et al.
2015/0282365	A1	10/2015	Escamilla et al.	2016/0087425	A1	3/2016	Sivakumar et al.
2015/0287875	A1	10/2015	Phu et al.	2016/0090662	A1	3/2016	Capulong et al.
2015/0288328	A1	10/2015	Swanson et al.	2016/0105027	A1	4/2016	Johnson et al.
2015/0311357	A1	10/2015	Harley et al.	2016/0108541	A1	4/2016	Abas et al.
2015/0325710	A1	11/2015	Tu	2016/0111583	A1	4/2016	Harrington et al.
2015/0326168	A1	11/2015	Johnson	2016/0112003	A1	4/2016	Morris et al.
2015/0326178	A1	11/2015	Capulong et al.	2016/0118516	A1	4/2016	Harley et al.
2015/0333617	A1	11/2015	Chapman et al.	2016/0133759	A1	5/2016	Pass et al.
2015/0340868	A1	11/2015	Chapman	2016/0133767	A1	5/2016	Smith et al.
2015/0342084	A1	11/2015	Dorenkamp et al.	2016/0134233	A1	5/2016	Chapman et al.
2015/0349158	A1	12/2015	Manning	2016/0142100	A1	5/2016	Rothblum et al.
2015/0349706	A1	12/2015	Grossman et al.	2016/0156309	A1	6/2016	Almogly et al.
2015/0349709	A1	12/2015	Ponec et al.	2016/0164300	A1	6/2016	Johnson et al.
2015/0364625	A1	12/2015	Solomon et al.	2016/0164427	A1	6/2016	Chapman et al.
2015/0372638	A1	12/2015	DeGraaff et al.				
2015/0377518	A1	12/2015	Maxey et al.				
2015/0380578	A1	12/2015	Zhu				
2016/0011246	A1	1/2016	Fischer et al.				

OTHER PUBLICATIONS

Flex Lighting Solutions Specification Sheets, Essentials Series,
Published May 2017 (9 pages).

* cited by examiner

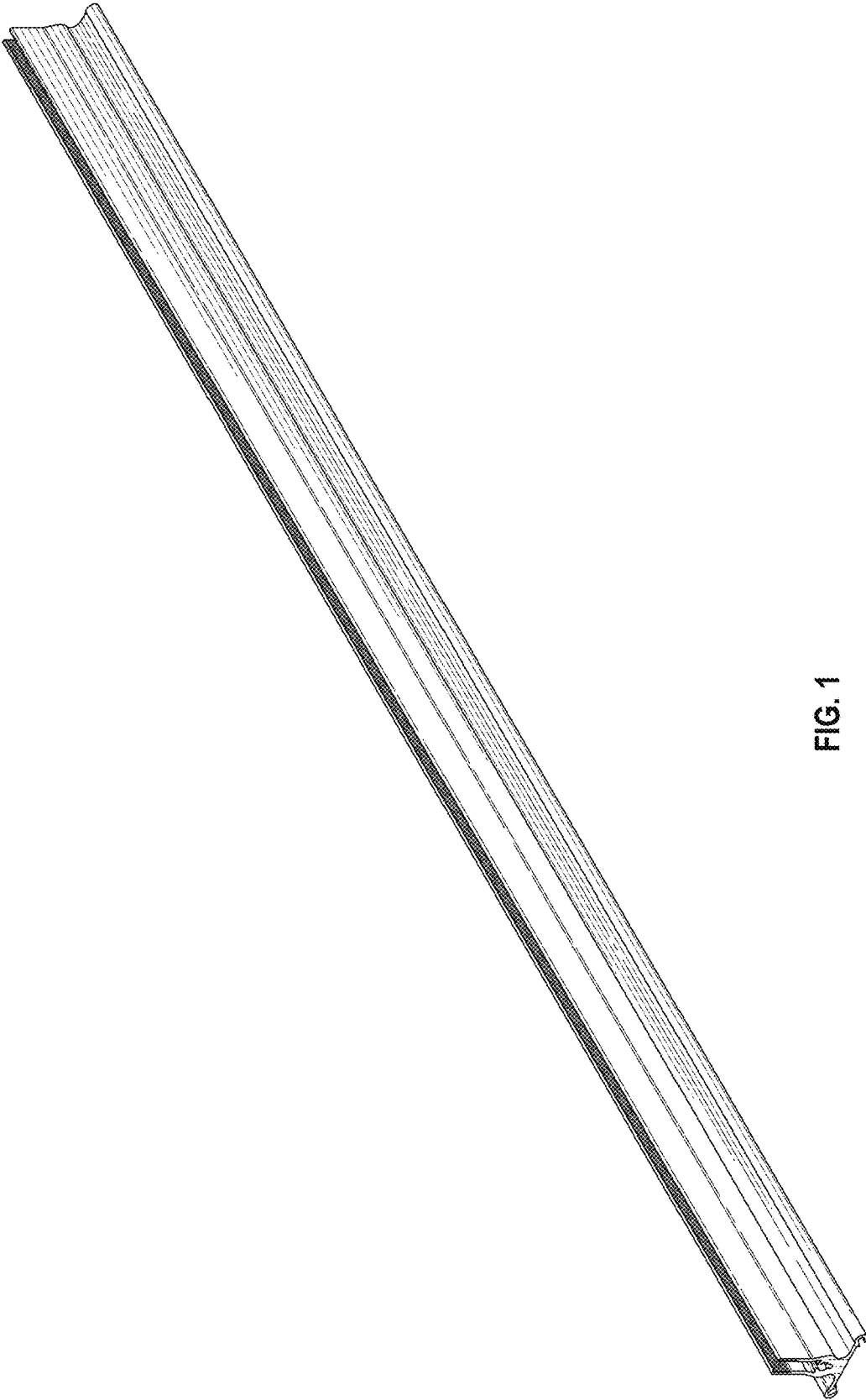

FIG. 1

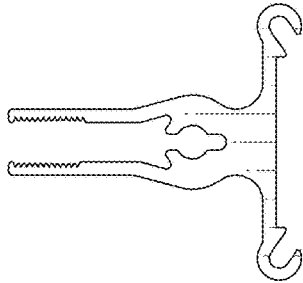

FIG. 2

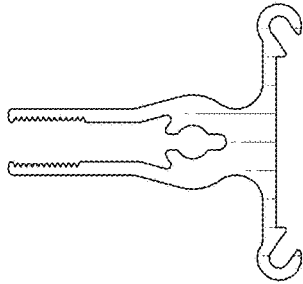

FIG. 3



FIG. 4



FIG. 5

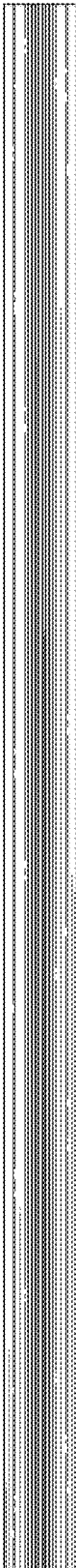

FIG. 6



FIG. 7