

M. NEUMANN.  
 AUTOMATIC CALF FEEDER.  
 APPLICATION FILED MAR. 14, 1919.

1,325,035.

Patented Dec. 16, 1919.  
 3 SHEETS—SHEET 1.

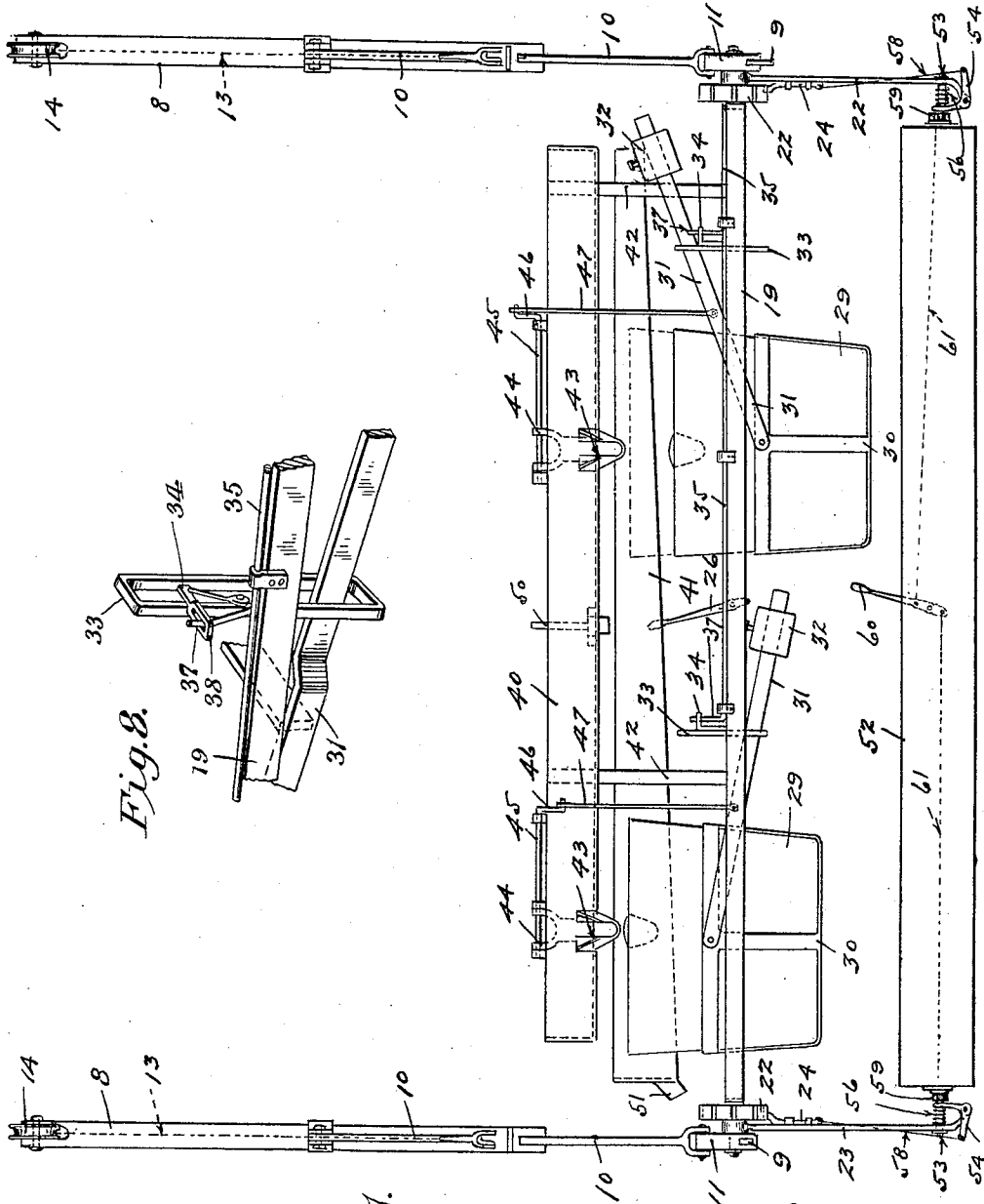

Fig. 8.

Fig. 1.

Witnesses  
 a H. Opsahl  
 Eva C. König

Inventor.  
 Math Neumann  
 By his Attorneys  
 Williamson, Neumann

1,325,035.

Patented Dec. 16, 1919.

3 SHEETS—SHEET 2.

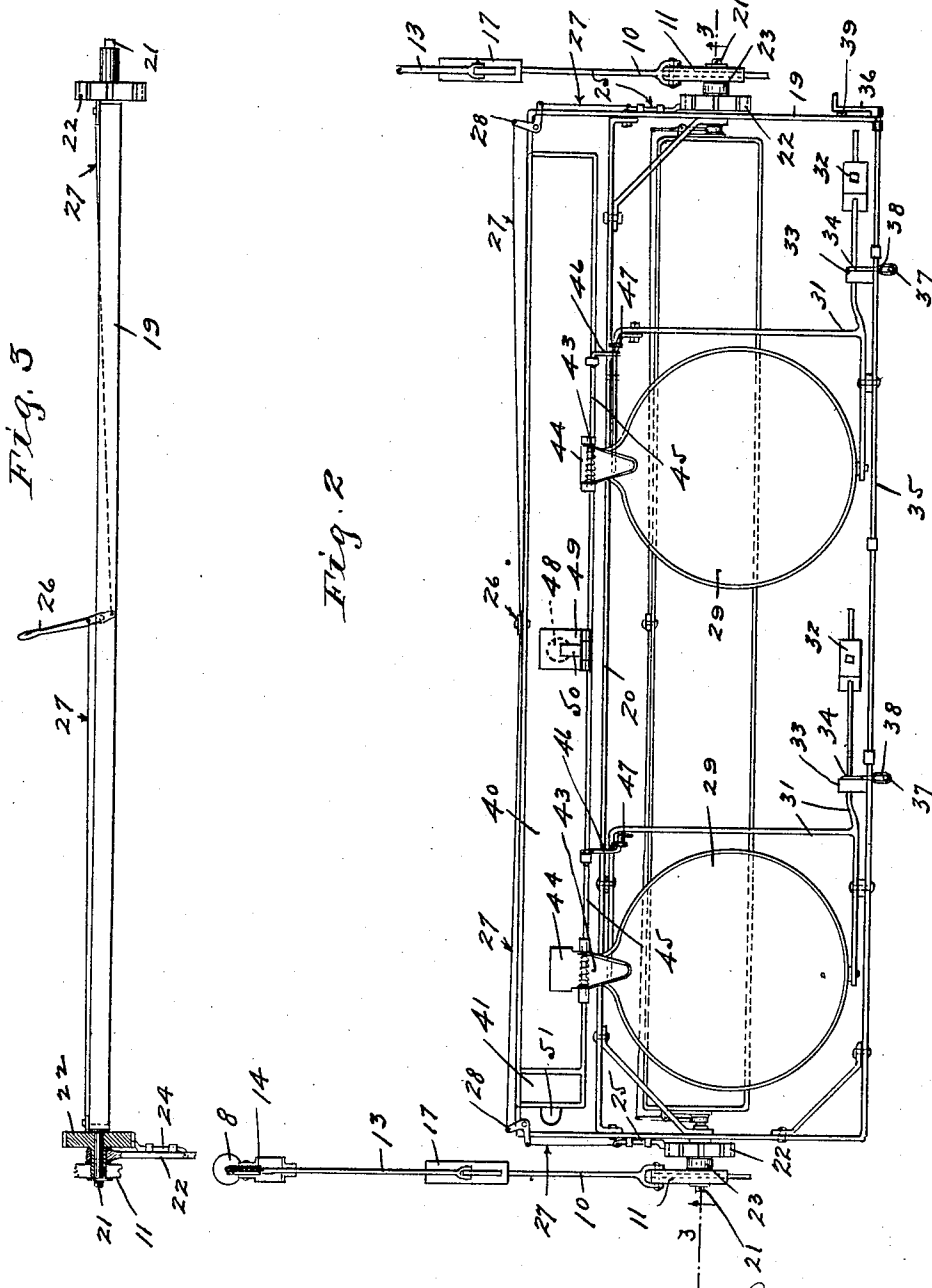

Witnesses.  
 A. H. Opsahl  
 Era C. König.

Inventor.  
 Math Neumann  
 By his Attorneys  
 Williamson & Neuman

M. NEUMANN.  
 AUTOMATIC CALF FEEDER.  
 APPLICATION FILED MAR. 14, 1919.

1,325,035.

Patented Dec. 16, 1919.  
 3 SHEETS—SHEET 3.

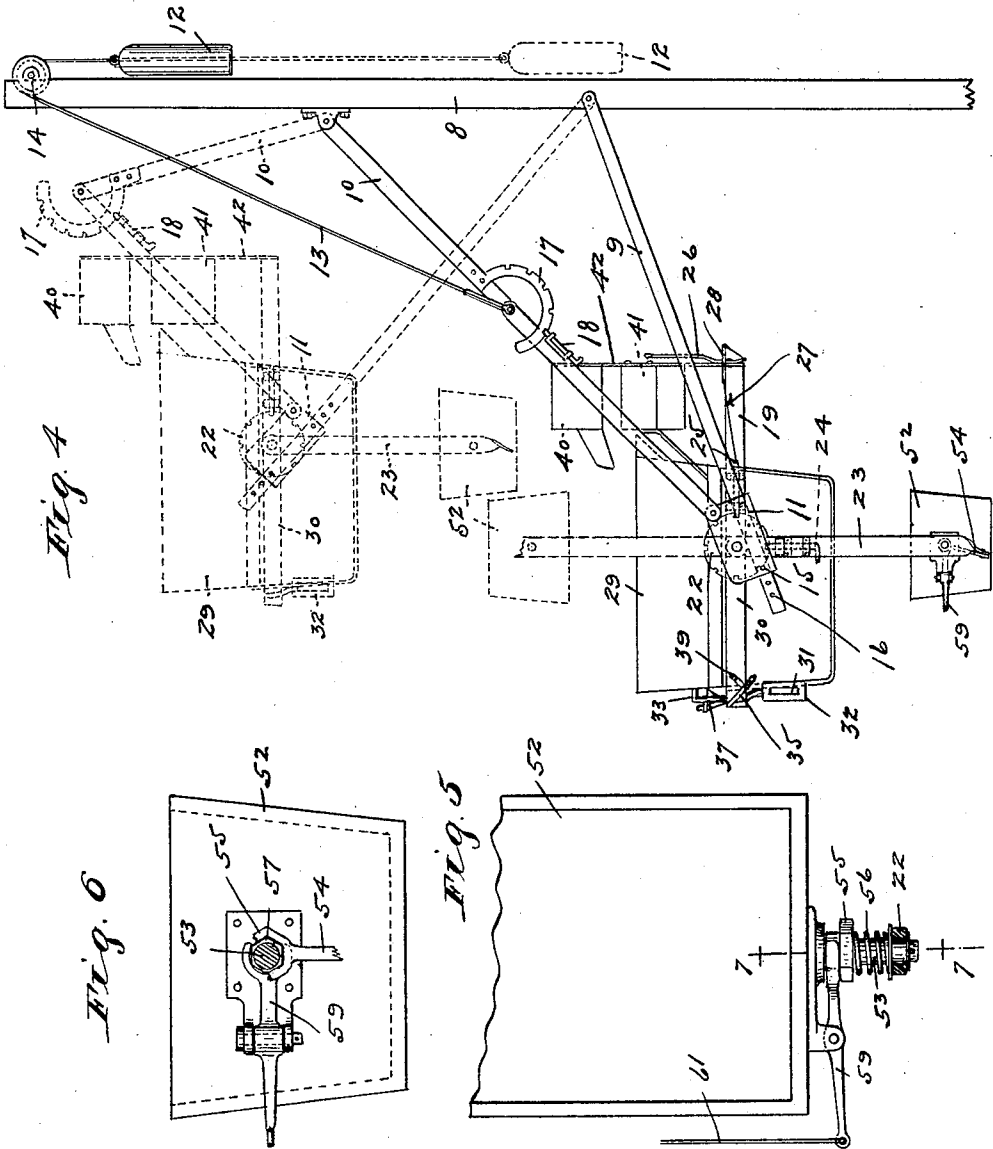

Witnesses,  
 A. H. Opahl  
 Eva E. König.

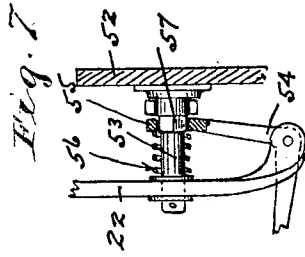

Inventor  
 Math Neumann  
 By his Attorneys  
 William Duerksen

# UNITED STATES PATENT OFFICE.

MATH NEUMANN, OF MONTICELLO, MINNESOTA.

## AUTOMATIC CALF-FEEDER.

1,325,035.

Specification of Letters Patent.

Patented Dec. 16, 1919.

Application filed March 14, 1919. Serial No. 282,729.

*To all whom it may concern:*

Be it known that I, MATH NEUMANN, a citizen of the United States, residing at Monticello, in the county of Wright and State of Minnesota, have invented certain new and useful Improvements in Automatic Calf-Feeders; and I do hereby declare the following to be a full, clear, and exact description of the invention, such as will enable others skilled in the art to which it appertains to make and use the same.

My present invention relates to automatic calf feeders and is in the nature of an improvement on U. S. Letters Patent, 1,276,946, issued to me August 27, 1918, and of the same title.

To the above end, the invention consists of the novel devices and combinations of devices hereinafter described and defined in the claims.

In the accompanying drawings, which illustrate the invention, like characters indicate like parts throughout the several views.

Referring to the drawings:

Figure 1 is a front elevation of the invention;

Fig. 2 is a fragmentary plan view of the same;

Fig. 3 is a detail view, with some parts sectioned on the line 3—3 of Fig. 2;

Fig. 4 is an end elevation, with some parts shown in different positions by means of broken lines;

Fig. 5 is a fragmentary plan view of the dry feed trough, with some parts sectioned;

Fig. 6 is an end elevation of the dry feed trough, with some parts sectioned;

Fig. 7 is a detail view with some parts sectioned on the line 7—7 of Fig. 5; and

Fig. 8 is a fragmentary perspective view of the frame and mechanism for supporting one of the drinking pails.

The numeral 8 indicates two laterally spaced upright posts or timbers, which may or may not be a part of a barn structure, and from which the feeding apparatus is either directly or indirectly supported.

Pivotaly secured to each post 8, for vertical swinging movement, is an arm 9, the outer end of which is supported from the respective post by an overlying toggle link 10. Slidably mounted on the arms 9, are blocks 11 to which the links 10 are pivoted and which blocks afford the connections between said arms and links.

Counterweights 12 for the feeding apparatus are secured by cables 13, one to each of the joints of the toggle links 10. The intermediate portions of the cables 13 run over guide sheaves 14 journaled on the upper ends of the post 8. These counterweights 12 tend to buckle the toggle links 10 and raise the outer ends of the arms 9, as indicated by broken lines in Fig. 4. The blocks 11 are held against inward sliding movement on the arms 9 and in different longitudinal adjustment thereon by pins 15 mounted in said blocks and adapted to be inserted through any one of a plurality of longitudinally spaced holes 16 in said arms. To secure the members of the toggle links 10 in alignment, or in different angular adjustment, and thereby support the outer ends of the arms 9 in different elevations, there is secured to one of the members of each link a notched segment 17, and to the other member thereof a cooperating lock bolt 18.

Located between the arms 9 and supported from the sliding blocks 11, is a horizontal rectangular frame 19 having a longitudinal central bar 20 that is suitably braced therefrom. A pair of alined trunnions 21 are rigidly secured to the ends of the frame 19 and journaled in the sliding blocks 11. On each trunnion 21, is loosely journaled a notched wheel 22 having a hub on which is pivoted a depending arm 23. Sliding bolts 24 are mounted on the arms 23 for engagement with the notched wheels 22 to lock said arms and wheels for common movement on the trunnions 21. To lock the frame 19 to the wheels 22, sliding bolts 25 are mounted on the ends of said frame for interlocking engagement with said wheels. To release the sliding bolts 25, there is intermediately pivoted to the back of the frame 19 a hand lever 26, which is connected on opposite sides of its fulcrum to the sliding bolts 25 by a pair of reversely extended rods 27. Bell cranks 28 are interposed in the connections 27 at the two rear corners of the frame 19.

Two drinking pails 29 are removably mounted, each in a skeleton bracket 30, pivotaly suspended, at diametrically opposite points, from the prongs of a bifurcated lever or scale beam 31. The prongs of said lever 31 are, in turn, intermediately pivoted, at diametrically opposite points, in the front bar of the frame 19 and the bar 20. On the free end of each lever 31, is an ad-

justable sliding weight or poise 32. If desired, the levers 31 may be graduated to indicate pounds or fractions thereof for co-operation with the weights 32, as in my above identified patent. When the drinking pails 29 are emptied, the weights 32 hold the same in raised positions, as indicated at the left, in respect to Fig. 1.

The levers 31, forward of the weights 32, work in loop-like guides 33 secured to the front bar of the frame 19. Spring-projected latches 34 are provided for automatically securing the levers 31 in raised positions. These latches 34 are pivoted to the guides 33, yieldingly held in the path of movement of the lever 31 and adapted to be cammed by said levers out of their paths of upward movement, as in my hereinbefore identified patent. After the levers 31 have passed above the latches 34, said latches are spring-projected in their paths of movement, and thereby hold said levers with the pails 29 in their lowermost positions. To release the latches 34, there is mounted on the frame 19 a rock shaft 35 having on its outer end an operating crank 36 and also having a pair of upwardly projecting fingers 37. These fingers 37 project through elongated openings 38 in the latches 34 and normally permit free movement of said latches to and from operative positions. A latch plate 39 on the frame 19, with which the crank 36 yieldingly interlocks, is provided for holding said crank, and hence, the fingers 37 in different positions.

An upper trough 40 and a lower trough 41 are supported by legs 42 from the frame 19. Milk or other liquid food to be fed to the calves is poured into the trough 40 and distributed therefrom to the drinking pails 29. Two spout-equipped ports 43 are formed in the front of the upper trough 40 and arranged to discharge into the drinking pails 29. These ports 43 are normally closed, from the inside, by flap valves 44 secured on shafts 45 journaled on the trough 40 and provided with cranks 46, which are connected by links 47 to the levers 31. These connections between the levers 31 and valves 44 are arranged to open said valves when the drinking pails 29 are raised.

In the bottom of the trough 40 is a drain 48 normally closed by a spring-pressed flap valve 49 and through which drain the contents in the trough 40 may be drained into the trough 41. Secured to the valve 49, is a hand piece 50 which projects above the trough 40. The trough 41 is inclined toward one end and in its lowest end is a discharge spout 51.

A trough 52, for meal or other dry food, is provided at its ends with a pair of aligned trunnions 53 journaled in the arms 23. To lock the trough 52 to the arms 23, bell cranks 54 are pivoted to the projected lower ends

of the arms 23 and have on their vertical arms heads 54 with angular openings through which project the trunnions 53. Coiled springs 56, encircling the trunnions 53, are compressed between the arms 23 and the heads 55 on the bell cranks 54, and normally hold said heads interlocked with angular hubs 57 on said trunnions. The other or horizontal arms of the bell cranks 54 are connected by rods 58 to the sliding bolts 24. To release the bell cranks 54 from the hubs 57, there is fulcrumed to the ends of the trough 52 shipper levers 59, the prongs of which embrace the trunnions 53 between the ends of said trough and the bell crank 54. These shipper levers 59 are simultaneously operated by a hand lever 60 intermediately pivoted to the back of the trough 52 and connected to said levers by a pair of reversely extended rods 61.

#### *Operation.*

The operation of the above described invention may be briefly described as follows:—

Before feeding takes place, the pails 29, being empty, are independently held in their raised positions by the weights 32. In this position of the pails 29, the valves 44 are held open by the connections 45—46 and 47. Milk or other liquid to be fed to the calves is poured into the trough 40 and part thereof will flow through the open ports 43 and into the pails 29. As the raised pails 29 are filling, the increasing weight therein will overcome the weights 32 and carry said pails downward. This downward movement of the pails 29 will gradually, and then finally close the valve 44, and, at the limit of the upward movement of the weighted ends of the levers 31, said levers are automatically locked against return movement by the latches 34, as previously described. Meal or other dry food to be fed to the calves is placed in the trough 52.

By buckling the links 10, the pails 29 may be supported in different elevation above the floor. While only two pails 29 are shown, it is, of course, understood that any desired number may be provided. If only one pail 29 is to be used, the other one may be lowered and held by the respective latch 34. If any milk remains in the trough 40, the same may be drained through the opening 48 into the trough 41 and from said trough 41, it is discharged through the spout 51 into a receptacle provided to receive the same.

After the feeding has taken place, the pails 29 may be removed from their holders, cleansed and replaced, and the apparatus then raised by releasing the latches 18 and buckling the links 10, as indicated by broken lines in Fig. 4. The counterweight 12, of course, holds the apparatus where set. By operating the lever 26, the sliding bolts 25

may be simultaneously released from the wheels 22, thus permitting the apparatus to be turned on the trunnions 21 to adjust the same horizontally or turn said apparatus upside down. Latches may, of course, be provided for securing the pails 29 in their frames 30, as in my prior patent, heretofore referred to. Also, by operating the lever 60, the latches 24 may be simultaneously released from the notched wheels 22, thus releasing the arm 23 for swinging movement on the trunnions 21, and the shipper levers 59 are also simultaneously operated therewith to release the bell cranks 54, and thereby permit the trough 52 to be turned on its trunnions 53.

What I claim is:—

1. In a stock feeding apparatus, the combination with a vertically adjustable support, of a frame pivoted at each end to said support, notched members secured in respect to the ends of the frame, a pair of depending arms having their upper ends loosely pivoted at the axes of the notched members, a trough pivotally supported at its ends from said arms, and latches for adjustably and independently locking the frame and arms to the notched members and adjustably locking the trough to the arms.

2. In a stock feeding apparatus, the combination with a vertically adjustable support, of a frame pivoted at each end to said support, notched members secured in respect to the ends of the frame, a pair of depending arms having their upper ends loosely pivoted at the axes of the notched members, a trough pivotally supported at its ends from said arms, latches for adjustably and independently locking the frame and arms to the notched members and adjustably locking the trough to the arms, and means for simultaneously releasing the latches for the arms and trough.

3. In a stock feeding apparatus, the combination with a vertically adjustable support, of a pair of arms loosely pivoted to the support, a trough pivoted to the arms, latches adjustably locking the arms to the support and the trough to the arms, and means for simultaneously releasing the latches.

In testimony whereof I affix my signature in presence of two witnesses.

MATH NEUMANN.

Witnesses:

J. W. PORIBYL,  
T. W. REMSON.