

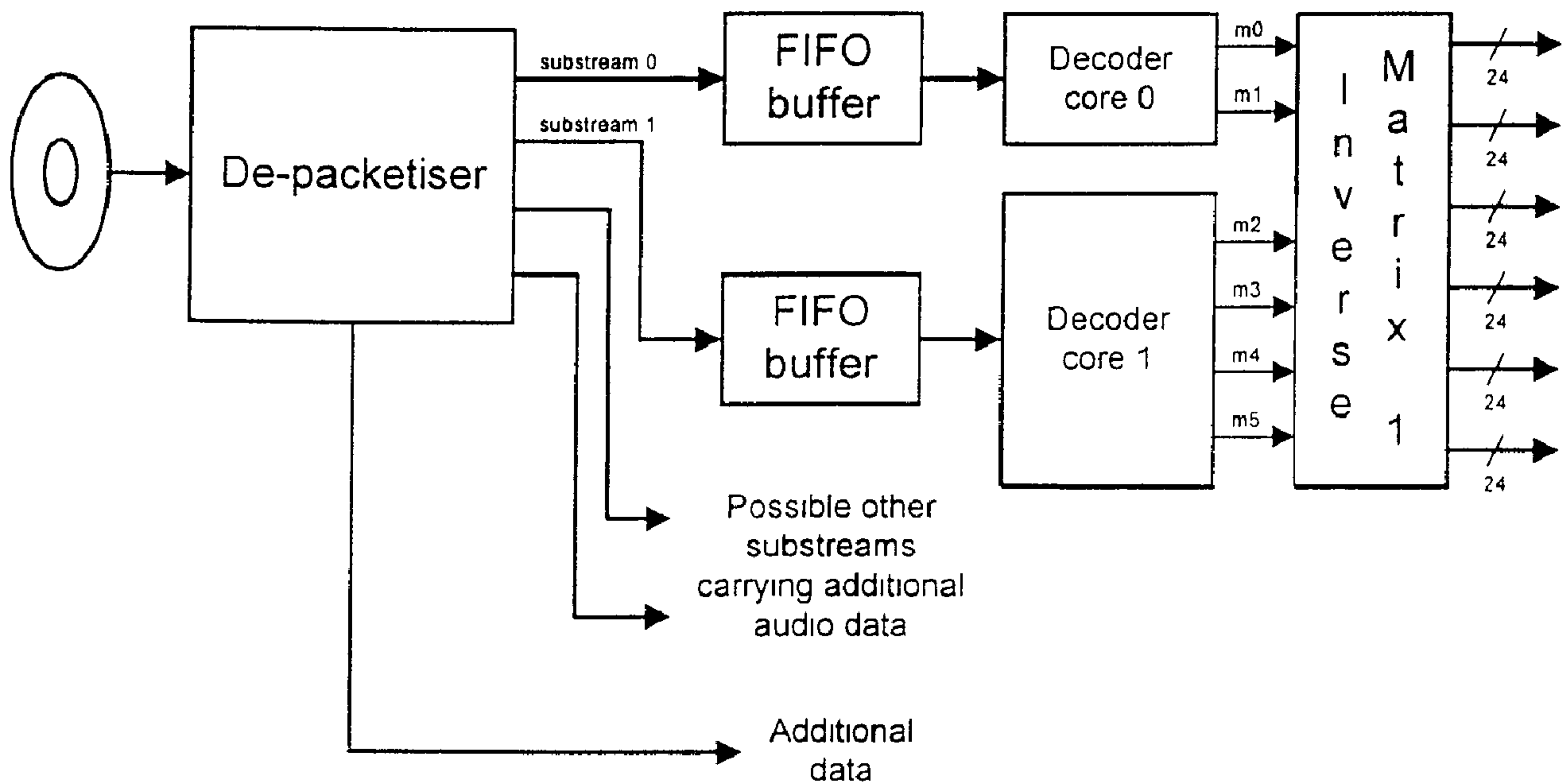

(86) Date de dépôt PCT/PCT Filing Date: 2000/04/07
 (87) Date publication PCT/PCT Publication Date: 2000/10/12
 (85) Entrée phase nationale/National Entry: 2001/09/24
 (86) N° demande PCT/PCT Application No.: GB 2000/001308
 (87) N° publication PCT/PCT Publication No.: 2000/060746
 (30) Priorités/Priorities: 1999/04/07 (9907919.6) GB;
 1999/04/07 (9907918.8) GB

(51) Cl.Int.⁷/Int.Cl.⁷ H04S 3/02, H04H 5/00
 (71) Demandeur/Applicant:
 DOLBY LABORATORIES LICENSING CORPORATION,
 US
 (72) Inventeurs/Inventors:
 STUART, JOHN ROBERT, GB;
 LAW, MALCOLM JAMES, GB;
 CRAVEN, PETER GRAHAM, GB
 (74) Agent: SMART & BIGGAR

(54) Titre : PERFECTIONNEMENTS MATRICIELS DE CODAGE ET DE DECODAGE SANS PERTE
 (54) Title: MATRIXING IMPROVEMENTS TO LOSSLESS ENCODING AND DECODING



(57) **Abrégé/Abstract:**

A lossless encoder and decoder are provided for transmitting a multichannel signal on a medium such as DVD-Audio. The encoder accepts additionally a downmix specification and splits the encoded stream into two substreams, such that a two-channel decoder of meagre computational power can implement the downmix specification by decoding one substream, while a multichannel decoder can decode the original multichannel signal losslessly using both substreams. Further features provide for efficient implementation on 24-bit processors, for confirmation of lossless reproduction to the user, and for benign behaviour in the case of downmix specifications that result in overload. The principle is also extended to mixed-rate signals, where for example some input channels are sampled at 48kHz and some are sampled at 96kHz.

(12) INTERNATIONAL APPLICATION PUBLISHED UNDER THE PATENT COOPERATION TREATY (PCT)

(19) World Intellectual Property Organization
International Bureau(43) International Publication Date
12 October 2000 (12.10.2000)

PCT

(10) International Publication Number
WO 00/60746 A3

- (51) International Patent Classification⁷: H04S 3/02, H04H 5/00
Stonecroft Close, Hangleton, Hove, East Sussex BN3 8BP (GB). STUART, John, Robert [GB/GB]; 21 Storeys Way, Cambridge CB3 0DP (GB).
- (21) International Application Number: PCT/GB00/01308
- (22) International Filing Date: 7 April 2000 (07.04.2000)
- (25) Filing Language: English
- (26) Publication Language: English
- (30) Priority Data:
9907918.8 7 April 1999 (07.04.1999) GB
9907919.6 7 April 1999 (07.04.1999) GB
- (74) Agent: ELKINGTON AND FIFE; Prospect House, 8 Pembroke Road, Sevenoaks, Kent TN13 1XR (GB).
- (81) Designated States (*national*): AE, AL, AM, AT, AU, AZ, BA, BB, BG, BR, BY, CA, CH, CN, CR, CU, CZ, DE, DK, DM, EE, ES, FI, GB, GD, GE, GH, GM, HR, HU, ID, IL, IN, IS, JP, KE, KG, KP, KR, KZ, LC, LK, LR, LS, LT, LU, LV, MA, MD, MG, MK, MN, MW, MX, NO, NZ, PL, PT, RO, RU, SD, SE, SG, SI, SK, SL, TJ, TM, TR, TT, TZ, UA, UG, US, UZ, VN, YU, ZA, ZW.
- (71) Applicant (*for all designated States except US*): DOLBY LABORATORIES LICENSING CORPORATION [US/US]; 100 Potrero Avenue, San Francisco, CA 94103 (US).
- (72) Inventors; and
- (75) Inventors/Applicants (*for US only*): CRAVEN, Peter, Graham [GB/GB]; 6 Kings Road, Lancing, West Sussex BN15 8EA (GB). LAW, Malcolm, James [GB/GB]; 14
- (84) Designated States (*regional*): ARIPO patent (GH, GM, KE, LS, MW, SD, SL, SZ, TZ, UG, ZW), Eurasian patent (AM, AZ, BY, KG, KZ, MD, RU, TJ, TM), European patent (AT, BE, CH, CY, DE, DK, ES, FI, FR, GB, GR, IE, IT, LU, MC, NL, PT, SE), OAPI patent (BF, BJ, CF, CG, CI, CM, GA, GN, GW, ML, MR, NE, SN, TD, TG).
- Published:
— With international search report.

[Continued on next page]

(54) Title: MATRIXING FOR LOSSELESS ENCODING AND DECODING OF MULTICHANNELS AUDIO SIGNALS

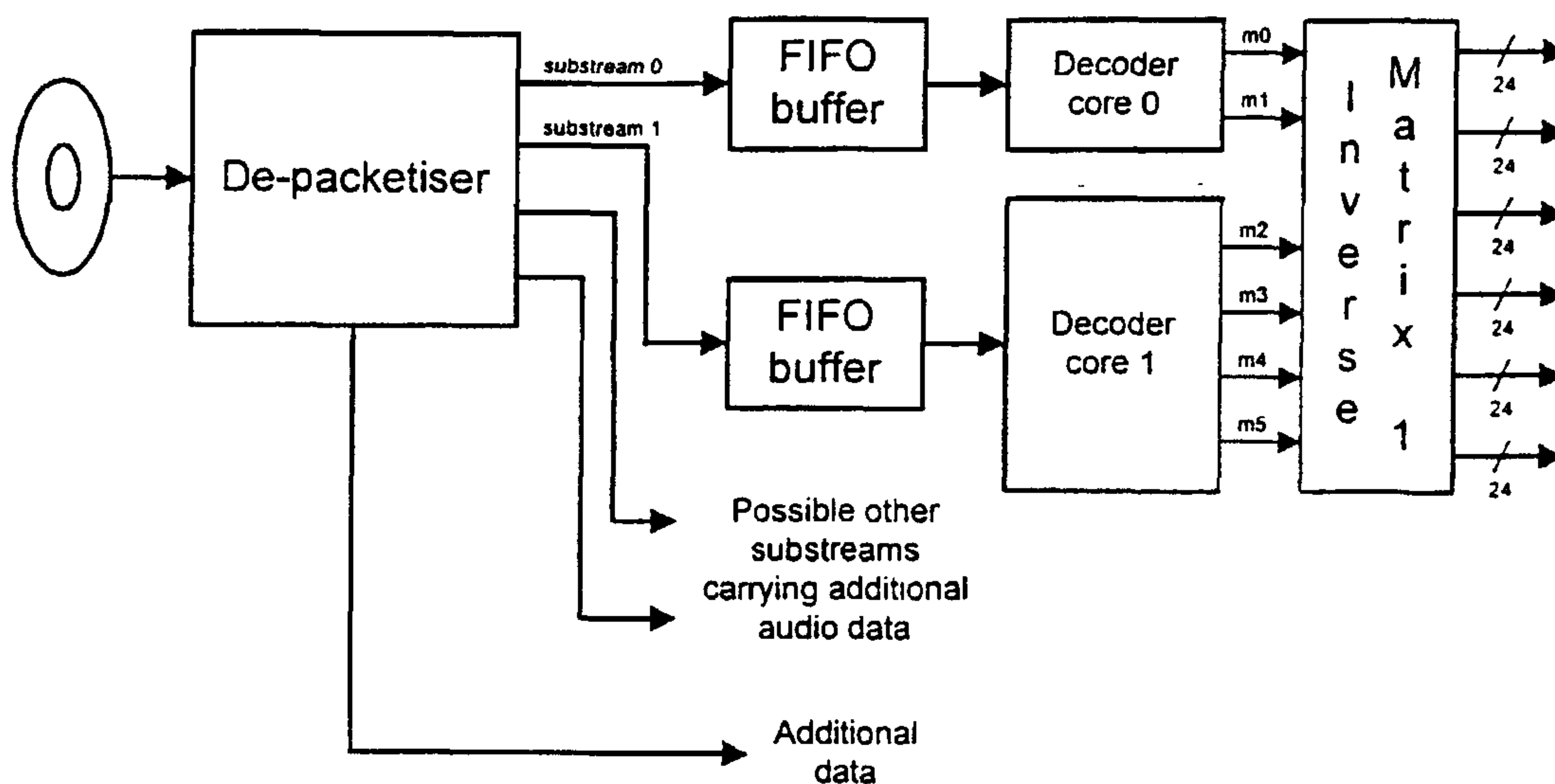

(57) Abstract: A lossless encoder and decoder are provided for transmitting a multichannel signal on a medium such as DVD-Audio. The encoder accepts additionally a downmix specification and splits the encoded stream into two substreams, such that a two-channel decoder of meagre computational power can implement the downmix specification by decoding one substream, while a multichannel decoder can decode the original multichannel signal losslessly using both substreams. Further features provide for efficient implementation on 24-bit processors, for confirmation of lossless reproduction to the user, and for benign behaviour in the case of downmix specifications that result in overload. The principle is also extended to mixed-rate signals, where for example some input channels are sampled at 48kHz and some are sampled at 96kHz.

WO 00/60746 A3

WO 00/60746 A3



(88) Date of publication of the international search report:
8 March 2001

For two-letter codes and other abbreviations, refer to the "Guidance Notes on Codes and Abbreviations" appearing at the beginning of each regular issue of the PCT Gazette.

- 1 -

DESCRIPTION**MATRIX IMPROVEMENTS TO LOSSLESS ENCODING AND DECODING****Field of Invention**

The invention relates to the encoding and decoding of digital signal streams, particularly digital audio streams, with reference to matrixing multichannel signals.

Background to the Invention

Lossless compression is now an established means of reducing the data rate required for storing or transmitting a digital audio signal. One method of reducing the data rate of a multichannel signal is to apply matrixing so that dominant information is concentrated in some of the transmitted channels while the other channels carry relatively little information. For example, two-channel audio may have nearly the same waveform in the left and right channels if conveying a central sound image, in which case it is more efficient to encode the sum and difference of the two channels. This process is described in some detail in WO-A 96/37048, including the use of a cascade of 'primitive matrix quantisers' to achieve the matrixing in a perfectly invertible or lossless manner.

The process disclosed in WO-A 96/37048 also envisages the use of matrix quantisers to apply a matrix to a multichannel original digital signal in order to derive matrixed digital signals representing speaker feeds more suitable for general domestic listening. These matrixed signals may be recorded on a carrier such as a DVD, and the ordinary player will simply feed each matrixed signal to a loudspeaker. The advanced player, however, may invert the effect of the matrix quantisers and thus reconstruct the original digital signal exactly in order to reproduce it in an alternative manner.

In a commercial application of DVD-Audio there is a requirement to combine the above two concepts so that a transmission system using lossless compression may also provide both a matrixed signal and an original signal. In this application the required matrixed signal has two

- 2 -

channels whereas the original signal has more than two channels, thus additional information must be provided to allow the multichannel signal to be recovered; however, the additional information should not impose a computational overhead for decoders that wish to decode the two-channel matrixed signal only.

Currently, digital audio is often transmitted with 24 bits, and popular Digital Signal Processing (DSP) chips designed for audio such as the Motorola 56000 series also easily handle a 24-bit word. However the processing described in WO-A 96/37048 can generate numbers requiring a word width greater than the original signal. Because the use of 'double-precision' computation is prohibitively expensive, a method is needed to allow the processing to be substantially carried out while not requiring an increased word width.

Finally the consumer, having bought equipment designed to provide lossless reproduction, would like reassurance that the signal recovered is indeed lossless. Conventional parity and CRC checks within the encoded stream will show errors due to data corruption within the stream, but they will not expose errors due to matrixing or other algorithmic mismatch between an encoder and a decoder.

Summary of the Invention

According to a first aspect of the invention, there is provided a stream divided into two substreams, the first substream providing information relating to a 'downmix' signal obtained by matrixing and containing fewer channels than an original multichannel digital signal, and the second substream providing additional information allowing the original multichannel digital signal to be losslessly recovered by a decoder. In the context where both substreams are conveyed using lossless compression, a decoder that decodes only the downmix signal needs to decompress the first substream only and can therefore use fewer computational resources than are required to decode the multichannel digital signal.

In a variant of this first aspect, the first substream may be replaced by a plurality of substreams, allowing a plurality of different matrixed presentations to be selected. Again however, the last substream will contain additional information that allows a complete original multichannel digital signal to be reproduced losslessly.

- 3 -

In a preferred implementation of the first aspect an encoder furnishes the downmix signal using a cascade of one or more primitive matrix quantisers, each of which implements an n by n matrix, followed by selection of the m channels required for the downmix.

A multichannel decoder will take the signals from both substreams and apply a cascade of inverse primitive matrices in order to recover the original multichannel signal. It might be considered natural to order the channels that are input to the decoder's cascade so that the channels from the first substream are placed at the beginning. However this may result in incorrect channel ordering at the output of the decoder's cascade, so preferably a channel permutation is specified by the encoder and implemented by the decoder to recover the correct channel order.

Preferably, any truncation or rounding within the matrixing should be computed using dither. In this case, for lossless coding, the dither signal must be made available to the decoder in order that it may invert the computations performed by the encoder and thus recover the original signal losslessly. The dither may be computed using an 'autodither' method as envisaged in WO-A 96/37048; but in the context of a lossless compression scheme, autodither can be avoided by providing a dither seed in the encoded stream that allows a decoder to synchronize its dithering process to that which was used by the encoder.

Therefore according to a second aspect of the invention, there is provided a lossless compression system including a dither seed in the encoded bitstream. The dither seed is used to synchronise a pseudo-random sequence generator in the decoder with a functionally identical generator in an encoder.

In an important application of the invention, the downmix has two channels, and is most conveniently derived by the application of two primitive matrix quantisers to the original multichannel digital signal. In embodiments that implement the second aspect of the invention, dither is required by each quantiser; moreover different dither should be provided for the two quantisers and the preferred probability distribution function (PDF) for each dither is triangular. An efficient way to furnish two such triangular PDF (TPDF) dither signals, which is referred to herein as 'diamond dither', is to add and subtract two independent rectangular PDF (RPDF) signals. For further details and generalisation to more channels, see R. Wannamaker, "Efficient Generation of Multichannel Dither Signals", AES 103rd Convention, New York, 1997, preprint

no. 4533.

Accordingly, in a preferred implementation of the second aspect, the encoder uses a single sequence generator to furnish two independent RPDF dither signals, and the sum and difference of these signals is used to provide the dither required by two primitive matrix quantisers used to derive a two-channel downmix.

WO-A 96/37048 describes the use of primitive matrix quantisers within a lossless compression system, and above we have referred to a preferred implementation of the first aspect, which also uses primitive matrix quantisers in order to place the information required for a 'downmix' signal into a separate substream.

Accordingly, in a third aspect of the invention there are provided encoders and decoders containing uncommitted primitive matrix quantisers, the encoder having logic that accepts a downmix specified as a matrix of coefficients, allocates a number of primitive matrix quantisers to furnish the downmix and optionally allocates a further number to provide matrixing to reduce the data rate. The encoder furnishes a stream containing specifications of the primitive matrix quantisers to be used, and optionally may include the addition of dither. In a preferred implementation, the dither is generated as two RPDF dither sequences, and the encoder specifies a coefficient for each dither sequence. Diamond dither is thus obtainable by specifying two coefficients of the same sign in the case of a first primitive matrix quantiser, and two coefficients of opposite sign in the case of a second primitive matrix quantiser.

In an elementary implementation of the third aspect, the primitive matrices are chosen so that the downmix signals are transmitted directly in the first substream. However, this may not be optimal for several reasons. Considering the n channels of a multichannel subspace as defining an n -dimensional vector space, the signals that result in a nonzero output in a linear downmix will form a subspace. If the downmix has m -channels then the subspace will usually also be of dimension m . The signals in the first substream should then convey the m -dimensional subspace optimally, which may require its transmitted channels to be a matrixed representation of the downmix channels. Thus matrixing facilities are usually needed even by a decoder designed to recover a downmix signal only.

Audio signals are normally conveyed using at most 24 bits, and in a lossless reproduction system such as Meridian Lossless Packing[®] (MLP), it is guaranteed that the output will not

- 5 -

exceed 24 bits because the original input did not exceed 24 bits. A description of MLP may be obtained from DVD Specifications for Read-Only Disc, Part 4: Audio Specifications, Packed PCM, MLP Reference Information, Version 1.0, March 1999, and from WO-A 96/37048. In the case of the downmix, the output level is defined by the matrix in the decoder. In principle one could scale the matrix coefficients so that the output can never exceed the saturation threshold defined by a 24-bit word, but in practice this results in unacceptably low output level. Moreover it is not acceptable for the encoder to limit or clip the downmix signals, as this cannot be done without affecting the reconstructed multichannel signal which would then not be lossless. An output level that exceeds the saturation threshold is referred to herein as 'overload'. Occasional overload of the downmix signal is considered acceptable, except that digital overload, if allowed to 'wrap-round', is extremely objectionable. The consequence of wrap-round is discussed below in more detail. Therefore in a preferred implementation of the first aspect of the invention, a decoder that decodes a downmix signal has clipping or similar limiting facilities after the computation of the matrix so that the effects of overload are not objectionable.

Another consequence of the 24-bit tradition in high quality audio is the availability of DSP processing chips having a 24-bit internal word width. Each primitive matrix quantiser as disclosed in WO-A 96/37048 modifies one channel of a multichannel signal by adding proportions of the other channels. Such a primitive matrix quantiser has a straight-through gain of unity. The invention in a fourth aspect provides for a primitive matrix quantiser that accepts a gain coefficient for the modified channel, and has an additional data path known as *lsb_bypass*. The gain may be set to a value less than unity in order to avoid overload. The quantised output of the primitive matrix quantiser will then contain less information than its input, with the remaining information being contained in additional least significant bits (LSBs) that are generated by application of the gain coefficient. Some or all of these LSBs are then transmitted separately through the *lsb_bypass* data path. In particular, in the case of a gain coefficient of $\pm\frac{1}{2}$, a single LSB is generated that can be conveyed through the *lsb_bypass*.

In a fifth aspect of the invention that provides a 'lossless_check' feature, a check value is computed on the multichannel input to the encoder and is conveyed in the encoded stream. The decoder computes a similar check value from the decoded output and compares it with the check value conveyed within the stream, typically to provide a visual indication such as a 'Lossless'

- 6 -

light to the listener that the reproduction is truly lossless. In the case of a stream with a downmix according to the first aspect of the invention, the downmix is not a lossless reproduction of an original signal. Nevertheless, if a synchronised dither is provided in the decoder according to the second aspect, and if the decoder matrixing is precisely described such as, for example, the matrix quantisers according to the third aspect of the invention, then the downmix reproduction is completely deterministic and can be simulated in the encoder and auditioned by a mastering engineer or producer. Therefore the encoder can compute a check value on the simulated downmix and this word can be checked by the decoder, thus confirming lossless reproduction of the same downmix that was auditioned or available for audition in the encoding process.

An encoder that incorporates for example, the 'prequantiser' described in P.G. Craven and J.R. Stuart, 'Cascadable Lossy Data Compression Using a Lossless Kernel', *J. Audio Eng. Soc.*, Abstracts, March 1997, vol. 45, no. 5, p. 404, preprint no. 4416, referred to herein as 'AES 1997', and which can therefore alter the original multichannel signal before encoding, has a choice on the computation of the check value. If it computes the check value from the original signal, an indication of lossless reproduction such as the 'Lossless light' on a decoder will not illuminate during passages that have been altered. An alternative is to make the altered signal available for audition as part of the encoding process, and to compute the check value from the altered signal. This is consistent with the downmix case: in both situations the Lossless light indicates lossless reproduction of a signal that was available for audition at the encoding stage.

In a preferred implementation, the check value is a parity-check word that is computed on all the channels. In an embodiment incorporating the first aspect of the invention, the first substream contains a parity-check word that is computed from the simulated downmix before any modification such as clipping is applied to avoid overload, while the second substream contains a parity-check word computed from the complete multichannel signal. Before computing the parity, the word representing each channel value is rotated by a number of bits equal to the channel number so that an error affecting two channels identically has a high probability of being detected.

Throughout this disclosure, more particular reference is made to encoding processes that record an encoded stream onto storage media such as DVD, and to decoding processes that retrieve the encoded stream from such storage media. It should be understood, however, that

encoders implemented according to the invention may be used to send encoded streams using essentially any transmission media including baseband or modulated communication paths throughout the spectrum from supersonic to ultraviolet frequencies, or may be used to record encoded streams onto storage media using essentially any recording technology including magnetic and optical techniques. Similarly, decoders implemented according to the invention may be used to process encoded streams obtained from such media.

Brief Description of the Drawings

Examples of the present invention will now be described with reference to the accompanying drawings, in which:

Figure 1 shows an overview of a lossless six channel encoder comprising a matrix that is used to encode the matrixed channels into two substreams, which are then packaged into a single stream and recorded on DVD.

Figure 2 shows a multichannel decoder decoding the two substreams produced by the encoder of figure 1 to furnish a lossless reconstruction of the original six channels.

Figure 3 shows a two-channel decoder decoding the first substream only to furnish a two channel downmix.

Figure 4a shows a cascade of two primitive matrix quantisers modifying two channels of a four channel signals.

Figure 4b shows a similar cascade of two primitive matrix quantisers, configured to invert the processing of figure 4a.

Figure 5a shows a primitive matrix quantiser incorporating dither.

Figure 5b shows an inverse primitive matrix quantiser incorporating dither.

Figure 6a shows a primitive matrix quantiser modified to provide the 'LSB bypass' facility, and the separate transmission of the bypassed in the case of any further lossless processing.

Figure 6b is complementary to figure 6a, showing the separate transmission of the bypassed LSB in the case of any inverse lossless processing, and a primitive matrix quantiser that integrates the bypassed LSB and reconstitutes the original signal.

Figure 7a shows a block diagram of part of one embodiment of an MLP encoder with LSB bypass.

Figure 7b shows one embodiment of a decoder that is complementary to the encoder of figure 7a.

Figure 8 shows a primitive matrix quantiser that is specified for use in one embodiment of an MLP decoder.

Figure 9 shows a lossless encoder preceded by a prequantiser with an output for audition, and a 'Lossless Check' value computed from the prequantised output.

Figure 10 shows an apparatus for encoding mixed-rate signal samples at 48kHz and 96kHz, comprising a lossless encoder preceded by an upsampler.

Detailed Description of the Invention

Downmix encoding and decoding

The article "Lossless Coding for Audio Discs", J. Audio Eng. Soc., September 1996, vol. 44, no. 9, pp. 706-720 and international patent application WO-A 96/37048 contain discussions of some of the principles used in lossless compression.

An important commercial application of lossless compression is on DVD-Audio, where there are two classes of player: the *multichannel* player furnishing 6 outputs used typically to drive a '5.1' speaker layout, and the *two channel* player furnishing two outputs for listeners with two loudspeakers or for portable use with headphones.

Therefore, DVD-Audio has the capability to carry a recorded audio signal twice, once as a multichannel signal and again as a two-channel signal. However, carrying the signal twice has adverse implications for playing time. In many cases the original recording is presented as a multichannel signal only, and the two channel listener is given a *downmix* derived from the multichannel master.

If the recorded audio is carried as conventional Pulse Code Modulation (PCM) samples, the disc may advantageously carry the multichannel recording plus *downmix coefficients* that allow the player to derive a two channel downmix as a linear combination of the channels of the

- 9 -

multichannel signals. For example a downmix consisting of the two channels L_0 and R_0 could be computed from a multichannel signal containing left-front, right-front, left-surround, right-surround, centre and low-frequency-effects channels, which are denoted L_f , R_f , L_s , R_s , C and L_{fe} , respectively, using the matrix equation:

$$\begin{bmatrix} L_0 \\ R_0 \end{bmatrix} = \begin{bmatrix} .75 & 0 & .739200 & -.126825 & -.5 & .5 \\ 0 & .75 & -.126825 & .739200 & -.5 & .5 \end{bmatrix} \begin{bmatrix} L_f \\ R_f \\ L_s \\ R_s \\ C \\ L_{fe} \end{bmatrix}$$

The computation of the downmix within the player is however less attractive when lossless compression is used. All six channels of the multichannel signal must be decoded before the above matrix equation could be applied, and the computational overhead of decoding six channels is excessive in this context.

An example of a solution to this problem is shown in figures 1, 2 and 3. In figure 1, the multichannel signal presented to the encoder is fed to 'Matrix 1', in this case a 6x6 matrix, whose outputs $m_0 \dots m_5$ are partitioned into the two subsets $\{m_0, m_1\}$ and $\{m_2, m_3, m_4, m_5\}$. These subsets are then encoded by 'Encoder core 0' and 'Encoder core 1' into two separate *substreams*, designated 'substream 0' and 'substream 1'. Each substream is then fed through a FIFO buffer and the substreams are combined in the 'packetiser' to produce a composite output stream which may be on a medium such as a DVD, as shown in the figure. The reason for using a FIFO buffer is discussed in US patent 6,023,233, and is illustrated in M.A. Gerzon, P.G. Craven, J.R. Stuart, M.J. Law and R.J. Wilson "The MLP Lossless Compression System" presented at the AES 17th International Conference on High Quality Audio Coding, Florence, September 1998, referred to herein as 'AES 1998'.

To play the multichannel signal encoded by the encoder shown in figure 1, a decoder such as that shown in figure 2 is used. In this decoder, a 'de-packetiser' receives an encoded stream from a transmission medium or storage medium such as a DVD, as shown, parses the encoded stream and separates it into two substreams. Each substream is passed through a FIFO buffer and a 'decoder core' in order to furnish the signals $m_0 \dots m_5$. These signals are then passed through the inverse of Matrix 1 in order to furnish the original multichannel signal.

- 10 -

To play a two channel downmix, a decoder such as that shown in figure 3 is used. Here the substreams are separated but only substream 0 is retained, buffered and decoded to furnish signals m_0 and m_1 . From these the matrix Matrix 0 derives the desired signals L_0 and R_0 , assuming that the encoder has placed the correct information in m_0 and m_1 for this to be possible. For example, if the top two rows of Matrix 1 in the encoder of figure 1 contain downmix coefficients such as those in the 2×6 matrix shown above, the signals m_0 and m_1 will be the required downmix signals L_0 and R_0 . In this case 'Matrix 0' in figure 3 is redundant and can either be replaced by the identity matrix or omitted.

A distinguishing feature of the present invention is that it may be lossless throughout, so that the multichannel output signal obtained from the decoder of figure 2 is bit-for-bit identical to the input signal provided to the encoder of figure 1. Thus, the encoder and decoder cores, if present, must be lossless, and Matrix 1 and its inverse are also required to be lossless. The lossless encoder and decoder cores may be implemented in essentially any manner that provides for lossless coding but, in preferred embodiments, these processes are implemented according to the processes that are disclosed in WO-A 96/37048. Considerations for implementing Matrix 1 are discussed below in more detail.

This distinguishing feature of lossless coding allows a DVD or other medium to convey an encoded stream in a form that allows lossless recovery of an original multichannel signal and also allows simple recovery of a matrixed representation or downmix of the original signal using essentially the same storage space or bandwidth that would otherwise be required to convey only the original multichannel signal. In practical embodiments, the required storage space or bandwidth of a losslessly compressed signal incorporating a downmix may be very slightly higher than that required by the compressed multichannel signal alone due to the additional information conveyed in the encoded stream that is needed by the decoder to reverse the downmix and due to the fact the PMQs that are used to encode the downmix are not available for use to optimise the coding process.

One method of performing the matrixing losslessly is by using a cascade of *primitive matrix quantisers* (PMQs), which are disclosed as 'primitive matrices' in WO-A 96/37048. These PMQs are matrices that are used to modify the signal in one channel, using signal values obtained from other channels, in a manner that is invertible. In particular, WO-A 96/37048

discloses how lossless inverse matrixing may be performed by inverting the effect of each quantiser in reverse order. This is illustrated in figure 4a, showing two PMQs in cascade for use in an encoder, and figure 4b showing the two inverse PMQs in reverse order. In simple situations where there are, in particular, only two primitive matrix quantisers, then the signals $S1$, $S2$, $S3$ and $S4$ can be identified with original channels such as L_f , R_f , L_s , R_s , etc., and the modified signals $S1'$ and $S2'$ can be identified with L_0 and R_0 , or with signals m_0 and m_1 .

To verify bit-for-bit reconstruction of the original signal, observe that the quantiser Q_2 in figure 4b is fed with the same signal as the quantiser Q_2 in figure 4a. They, being assumed identical, therefore produce the same output q_2 . In figure 4a the signal $S2'$ is formed as $S2' = S2 - q_2$, while figure 4b performs the restoration $S2 = S2' + q_2$. With $S2$ thus restored, quantiser Q_1 in figure 4b is fed with the same signal as quantiser Q_1 in figure 4a, and signal $S1$ is restored in a manner similar to the manner $S2$ is restored.

The quantisers Q_1 and Q_2 are needed in order to prevent the word length of the modified signals $S1'$ and $S2'$ from exceeding that of the input signals $S1$ and $S2$, so that the information content is not increased.

Figure 4 shows just four channels for simplicity, but it will be seen how this principle can be extended to any number of channels and how a larger number of PMQs can be used in cascade. Each PMQ modifies just one audio channel, and in figure 4 only the first two channels are modified. In practice, any or all of the channels may be modified, and there is no restriction on order nor any prohibition that a given channel be modified more than once. In the case of a two-channel downmix, it would be normal for at least the first two channels to be modified.

It will be seen that each PMQ in figure 4 has a gain of unity to the channel it modifies. It is not possible to synthesise the most general matrix from a cascade of such PMQs: WO-A 96/37048 explains that the set is restricted to matrices having a determinant equal to one. In the general case, it is necessary to scale the downmix equations in order to obtain a determinant that has a unit magnitude. For example, in the case of the downmix equations displayed earlier, they should be scaled by $4/3$ so that Matrix 1 in the encoder implements:

- 12 -

$$\begin{bmatrix} m_0 \\ m_1 \end{bmatrix} = \begin{bmatrix} 1.0000 & 0. & .9856 & -.1691 & -.6667 & .6667 \\ 0. & 1.0000 & -.1691 & .9856 & -.6667 & .6667 \end{bmatrix} \begin{bmatrix} L_f \\ R_f \\ L_s \\ R_s \\ C \\ L_{fe} \end{bmatrix}$$

while Matrix 0 in the two-channel decoder implements the inverse scaling:

$$\begin{bmatrix} L_0 \\ R_0 \end{bmatrix} = \begin{bmatrix} .75 & 0 \\ 0 & .75 \end{bmatrix} \begin{bmatrix} m_0 \\ m_1 \end{bmatrix}$$

It is evident that Matrix 0 cannot be implemented as a cascade of PMQs because its determinant does not have a unit magnitude. This is not a problem because Matrix 0 is not required to provide lossless reconstruction of an original signal. An architecture that allows a two-channel decoder to implement Matrix 0 as either a strict cascade of PMQs for losslessly decoding a two-channel original signal, or as a more general matrix for downmix applications, is shown in figure 8 and described later.

To calculate the coefficients for the PMQs forming Matrix 0, the following procedure may be adopted. Denote by *downmix* the matrix of downmix coefficients, for example in the case considered above, we have

$$\text{downmix} = \begin{bmatrix} .75 & 0 & .739200 & -.126825 & -.5 & .5 \\ 0 & .75 & -.126825 & .739200 & -.5 & .5 \end{bmatrix}$$

Then for $j = 1 \dots 6$ calculate

$$\text{coeff}_{1,j} = \frac{\text{downmix}_{1,j}}{\text{downmix}_{1,1}},$$

then calculate

$$\text{coeff}_{2,1} = -\frac{\text{downmix}_{2,1}}{\text{coeff}_{1,2} \text{downmix}_{2,1} - \text{downmix}_{2,2}},$$

and then for $j = 3 \dots 6$ calculate

$$\text{coeff}_{2,j} = -\frac{\text{downmix}_{2,j}}{\text{coeff}_{1,2} \text{downmix}_{2,1} - \text{downmix}_{2,2}} - \text{coeff}_{2,1} \text{coeff}_{1,j}$$

The coefficients m_coeff in figures 4a and 4b for $i \ j$ are now given by the expression

- 13 -

$$m_coeff[i, j] = -coeff_{i, j}$$

where the minus sign arises because of the subtraction in figure 4a.

In the multichannel decoder of figure 2, the Inverse Matrix 1 may be implemented as in figure 4b, using the same values $m_coeff[i, j]$ as in the encoder, but with the reversed order of PMQs and with subtraction in each encoding PMQ replaced by an addition as shown. Note that the inputs $m_0 \dots m_5$ to the cascade of PMQs are derived from two substreams in this case.

Although the invention as so far described is particularly relevant in the context of compression, it is applicable generally and not restricted to compression systems. Also, the principle described above is not restricted to two substreams. For example, using three substreams a nine-channel signal can be conveyed losslessly, with the information required to decode a six-channel downmix carried in the first two substreams, and the information required to decode a two channel downmix (as a linear combination of the six channels) carried in only the first substream.

In current commercial applications, the matrix defining the downmix signals L_0, R_0 in terms of L_f, R_f, L_s, R_s, C and L_{fc} will generally have the largest coefficients multiplying L_f and R_f , as is the case in the example above. However, this situation cannot be guaranteed because the dominant coefficients may multiply some of the other signals. If the coefficients of L_f and R_f are indeed small, the requirement that a PMQ have unity gain to the channel that it modifies introduces a problem because one or more other channels should be scaled up accordingly. If simple scaling as shown above is used to address this problem, other coefficients of the matrix will exceed unity and, as a result, overload or other problems may occur.

This problem may be addressed by a permutation of the channels in the encoder so that for example a 'first' channel whose coefficient in L_0 is largest could be brought to the beginning of the sequence and a 'second' channel whose coefficient in R_0 is largest is brought to second place. In this example, it is assumed the first and second channels are not the same. This re-ordering usually makes it possible for the encoder to furnish matrixed signals m_0 and m_1 that are proportional to L_0 and R_0 by using two PMQs whose coefficients do not substantially exceed unity to modify the first two channels.

With such a permutation in the encoder, the multichannel decoder of figure 2 will require an inverse permutation in order to reproduce the signals in the correct order. Re-mapping of the

- 14 -

output channels is provided in an MLP decoder, as instructed by the *ch_assign* information in the encoded stream. In the case that the encoder uses a permutation, it may instruct the decoder to apply the inverse permutation by specifying the appropriate re-mapping.

The inverse permutation is applied after the decoder's matrixing if the encoder applies a permutation before matrixing. Another possibility would be to apply the permutation in the decoder before the matrixing if permutation is applied in the encoder after matrixing. Additionally, it would be possible for a decoder of an MLP stream to apply the permutation before the matrixing if the coefficients of the matrix are also permuted.

There are certain unlikely but possible downmix specifications that the strategies outlined above will not handle. One possibility is that L_0 and R_0 may have coefficients that are the same or nearly the same or, in other words the downmix is mono or nearly mono. In this situation the above procedure is unsatisfactory because the denominator of the expression for $coeff_{2,1}$ becomes zero or nearly zero, resulting in large coefficients and a high probability of overload. This problem can be solved by choosing m_0 and m_1 differently. Regarding the signals as elements of a vector space, the signals L_0 and R_0 will in general span a two-dimensional subspace of the 6-dimensional Euclidean vector space, or in general an n -dimensional Euclidean vector space, of which the channels of the multichannel signal form an orthonormal basis. The signals m_0 and m_1 must span this subspace if L_0 and R_0 are to be reconstructed. It is reasonable to choose m_0 and m_1 to be orthogonal or approximately orthogonal to each other in the subspace spanned by L_0 and R_0 . Having determined m_0 in terms of the input channels, these channels may be permuted prior to the matrix so that a channel whose coefficient in m_0 is largest, or substantially largest comes first. A PMQ is then computed as above so that the first transmitted channel is a scaled version of the desired m_0 . It is then necessary to compute a PMQ to furnish a scaled version of m_1 . Once again a prior permutation may be desirable in order to minimise the magnitude of coefficients. This permutation of the signals to be matrixed is akin to the process of 'partial pivoting' known to those skilled in the art of matrix computations, and will not be described further here. Initially, m_0 and m_1 may be given arbitrary scaling. Then the above procedure for coefficient determination may then be used by replacing the matrix *downmix* with the matrix giving m_0 and m_1 in terms of the original channels. The coefficients determined by this procedure will then determine the actual scaling of m_0 and m_1 .

- 15 -

In the degenerate case where L_0 and R_0 are identical signals or are scaled versions of each other, the subspace spanned by L_0 and R_0 will be one-dimensional. In this case m_0 may be chosen arbitrarily within the subspace and m_1 may be chosen to be orthogonal to m_0 but from outside the subspace. Matrix 0 in a two-channel decoder will then reconstitute L_0 and R_0 as a scaled version of m_0 and will ignore m_1 .

In the MLP lossless compression system, the coefficients of Matrix 0 are carried in the first substream, Substream 0, and the coefficients of Matrix 1 are carried entirely in the second substream, Substream 1, even though some of these coefficients are used to multiply signals decoded from the first substream.

Downmix encoding combined with data rate reduction

Lossless encoders using matrixing are discussed extensively in WO-A 96/37048, where the purpose of the matrixing is to reduce the correlation between the transmitted channels and thereby to reduce the transmitted data rate. In the case where a downmix is to be encoded as described above, the matrixing is partially specified by the downmix requirement, but considerable freedom in the specification remains.

Firstly, in choosing m_0 and m_1 , the condition that they be approximately orthogonal still allows an arbitrary rotation within the subspace spanned by L_0 and R_0 . This freedom may be used to minimise the data rate required to encode the first substream, Substream 0, for example using the methods discussed in WO-A 96/37048 that minimise the data rate taken by any signal of two or more channels.

Secondly, assuming for example a 6-channel multichannel signal, the matrixing of the four channels that are not modified to furnish the downmix is still completely unspecified. Once again, the methods described in WO-A 96/37048 may be used to minimise the data rate required to encode the second substream, Substream 1. In the case of a PMQ implementation, two PMQs may be used to derive the downmix, and any remaining PMQs may be used to minimise the data rate of the remaining four channels in the same way as for any other four channel signal. In the MLP compression system, six PMQs are available in total, allowing four to be allocated to this

- 16 -

task.

Dither

It is now regarded as extremely important in audiophile circles that any quantisation that affects the reproduction of the audio signal be performed using dither. Typically, a small pseudo-random dither value is added to the signal before it is passed to the quantiser. See for example S.P. Lipshitz, R.A. Wannamaker, and J. Vanderkooy, "Quantization and Dither: A Theoretical Survey," J. Audio Eng. Soc., May 1992, vol. 40, pp. 355–375.

The primitive matrix quantisers inherently perform quantisation. In the case of lossless encoding and decoding, the absence of dither is not a problem because the lossless matrixing in the decoder inverts exactly the matrixing performed in the encoder, including any quantisation effects. However in furnishing a downmix as described above, Matrix 0 does not invert the effect of Matrix 1, and the downmix will contain quantisation effects from both matrices.

In order to render the downmix quantisation benign, dither must be added by both matrices. However, adding dither in the encoder's Matrix 1 will affect the transmitted signal, and the decoding of the multichannel signal will be affected thereby. Therefore for lossless decoding, the Inverse Matrix 1 in the multichannel decoder must compensate for the effect of the dither in the encode matrixing.

Figures 5a and 5b show a complementary pair of primitive matrix quantisers including dither, in this case for a three channel signal. The two matrix quantisers differ only in that the signal q_1 is subtracted in the quantiser shown in figure 5a, whereas the same signal is added in the quantiser shown in figure 5b. It is easily seen that, provided the signal furnished by the box marked 'dither' is the same in both cases, the PMQ in figure 5b will undo the action of the PMQ in figure 5a. Thus, an encoder as shown in figure 1 can be constructed in which 'Matrix 1' is a cascade of PMQs as shown in figure 5a, and the multichannel decoder of figure 2 can be constructed in which 'Inverse Matrix 1' is a reversed-ordered cascade of PMQs as shown in figure 5b. This will ensure that the multichannel signal is reconstructed losslessly.

For the best quality downmix reproduction, the conventional requirements for dither

should be satisfied both in the encoder's 'Matrix 1' and in the decoder's 'Matrix 0'. Thus for example in the encoder, the dither generator in figures 5a and 5b could advantageously furnish TPDF dither with a peak-to-peak amplitude equal to two quantisation steps of the quantiser Q. If the first two PMQs in the encoder furnish the downmix signal, then it is not necessary to add dither to the later PMQs.

Matrix 0 may be a different type of matrix, but it will nevertheless include computation, which increases the word length, followed by quantisation, and it is normal to add dither before each quantisation.

The requirement for identical dither in the encoding and decoding quantisers of figures 5a and 5b can be met by the encoder recording a 'seed' conveying the state of a pseudo-random sequence generator within the stream from time to time, and the decoder reading the seed and thereby synchronising its own sequence generator.

In MLP the sequence generator is a 23-bit circular shift register generating a pseudo-random binary sequence (PRBS) using the expression:

$$b_{23} \oplus b_5 \oplus 1$$

where b_x represents bit x of the shift register, and

\oplus represents the exclusive-OR operation.

Thus the seed in the stream is 23 bits long. The shift register is shifted by 16 bits on each sample period. This allows a new 16-bit pseudo-random number with a rectangular PDF to be generated for each signal sample. However, because TPDF dither is preferred, the 16 bits are divided into two 8-bit dither samples. These 8-bit samples each have a rectangular PDF, but the encoder has the option to add and subtract these two samples to furnish two further uncorrelated dither samples having a triangular PDF. This process is known as 'Diamond Dither' and is explained in the above-cited Wannamaker reference, AES preprint no. 4533. The encoder can use these two triangular PDF samples to add dither to two PMQs that furnish the downmix signal.

Audiophile considerations do not require that the dither applied in Matrix 0 to recover the downmix signal be synchronised to a corresponding process in the encoder. Indeed it is undesirable that the same dither be applied, or that Matrix 0 apply any dither that is correlated with the dither applied in Matrix 1. In MLP the downmix decoder generates a dither signal using

- 18 -

the same algorithm as the multichannel decoder, but the dither is different because the seed is different: the seed for the Matrix 0 dither is carried in Substream 0, while the seed for the Matrix 1 dither is carried in substream 1.

In MLP, the quantisation and arithmetic of Matrix 0 are specified just as precisely as for Matrix 1, and with the dither also controlled by the encoder, the encoder has precise knowledge of the L_0 and R_0 signals recovered by the decoder, down to the last bit. We shall return to this point later.

Saturation of downmix

It is often considered commercially important to encode an audio signal at the maximum level that the digital channel can handle. Peaks in live music can be very 'uncontrolled' and the average level must be kept well below digital clipping if no peak of a live signal is to cause overload. However, the professional recording engineer is well equipped with tools for waveform modification, such as clippers and limiters, that allow him to produce a 'controlled' signal that modulates a channel very fully while ensuring that no peak will overload.

It will be understood that digital overload can result in extremely unpleasant artifacts caused by 'wrap-round' effects. For example, in conventional twos-complement 24-bit audio, the maximum positive value is represented by 7fffffff hexadecimal. A naïve attempt to increase this value by one quantisation level will result in 800000 hexadecimal, which is interpreted as the maximum negative excursion. Thus small overloads can generate full-scale transitions having a large high-frequency energy content, which sounds extremely unpleasant and frequently causes burn-out of tweeters.

In the context of DVD mastering, it is assumed that a 'controlled' multichannel master is produced and presented for lossless encoding. In other words, it is assumed that any overload problems in producing the multichannel signal have already been dealt with. The task remains to produce an acceptable L_0R_0 downmix.

Overload at the output of the two-channel decoder of figure 3 can be avoided by scaling down the coefficients of 'Matrix 0' sufficiently. However such scaling down has two problems.

- 19 -

Firstly the amount of scaling required is not known until the entire programme material has been examined, which is inconvenient at the mastering stage. Secondly, such scaling is likely to result in a downmix that is unacceptably quiet by commercial standards. This is because any prior clipping or limiting of the multichannel signal is not necessarily effective in constraining the peak-to-mean ratio of a downmix derived from the multichannel signal.

It is not possible to adjust the downmix at the encoding stage, because this would alter the transmission of m_0 and m_1 , and recovery of the multichannel signal would then not be lossless.

Accordingly, the invention provides for a downmix decoder to have the ability to generate internally a downmix signal having an amplitude larger than a digital output can handle, and to incorporate a limiter or clipper prior to the final output so that overload of the downmix signal is handled without unpleasant effects.

In MLP, the output word width is specified as 24 bits, and most of the internal signal paths, including the paths between the PMQs, are also specified as 24 bits wide. However, after the last PMQ in the decoder, a shifter is provided that shifts left or right by a variable number of bits specified by "*output_shift*" information carried from time to time in the encoded stream. If the encoder is given an input and a downmix specification that result in a downmix requiring more than 24 bits, the encoder scales down the downmix specification to avoid overload within the matrixing. This scaling down is by a power-of-two, so that the correct amplitude can be restored in the decoder by specifying a positive left shift in the "*output_shift*" information. The shifter in the decoder thus generates a downmix signal of the correct amplitude, which may be too large for the 24-bit output. Therefore a clipper is placed between the shifter and the output, in order to avoid the undesirable 'wrap-round' effect discussed earlier. The clipper may conveniently be implemented using the facility provided in many DSP chips whereby a value in an accumulator may be stored to memory using 'saturation arithmetic'.

An additional synergy arises in this case if the memory location to which the accumulator is stored can be calculated in dependence on the "*ch_assign*" information in the stream. This accomplishes the inverse permutation of channels required in a decoder without having to implement it as a separate operation.

- 20 -

LSB bypass

If an input signal exercises the full 24-bit range, then an attempt to modify a channel using a PMQ according to figure 4 or 5 is likely to lead to a signal that exceeds the 24-bit range. This increased range, which is internal to the lossless encoding and decoding process, can be accommodated economically even on a processor using 24-bit arithmetic by using the architecture of figure 6.

Figure 6a shows, on the left, a PMQ that incorporates a shifter. The signal paths are assumed to be 24 bits wide generally, but after the subtraction of the quantised signal q from $S1$ a 25-bit data path is provided to allow headroom for the addition. The signal is then shifted right arithmetically by one bit and the LSB shifted from the bottom of the word is output separately from the main output $S1'$, which contains the remaining 24 high-order bits.

The LSB thus shifted out must of course be carried with the signal. To decode the signals $S1$, $S2$ and $S3$, the LSB together with signals $S1'$, $S2$ and $S3$ should be presented to the inverse PMQ shown on the right of figure 6b. Here the LSB is appended to $S1'$ and the result is shifted left by one bit so that the separately carried LSB is the LSB of the shifted word, thereby giving a 25-bit signal to which the quantised signal q is added. The result of this addition is only 24 bits wide by virtue of lossless reconstruction of the signal $S1$ fed as input to the PMQ shown in figure 6a, provided that $S1$ is a 24 bit signal.

As shown on the right of figure 6a and on the left of figure 6b, it is possible to insert further lossless processing and inverse lossless processing of the 24-bit wide path between the two complementary PMQs, provided there is a bypass path so that the LSB is conveyed separately. For example, a partial block diagram of an MLP encoder is shown in figure 7a and the corresponding decoder is shown in figure 7b. A decorrelator and an entropy coder comes after the matrix shown in figure 7a; thus, in this example, the 'Lossless processing' shown in figure 6a would include these items. Similarly, referring to figure 7b, the 'Inverse Lossless Processing' shown in figure 6b could include an entropy decoder and a recorrelator. As shown in figures 7a and 7b, care is taken to preserve the bypassed LSB across this processing, to store it to and recover it from the encoded stream or substream.

Sometimes the matrixing in MLP does not cause overload, but the decorrelator, while

- 21 -

designed generally to reduce the signal amplitude, increases it on particular samples and thereby encounters an overload problem. In this case a PMQ of the type shown in figure 6a may be used to reduce the amplitude of the signal and thus provide approximately 6dB of headroom for further processing. The coefficients shown in figure 6 may be set to zero when a PMQ is used for this purpose only.

It will be clear that the scheme of figure 6a could be generalised to allow more than one bit to be shifted out from a PMQ and transmitted as a bypass signal. This is not done in MLP.

The processing shown in figure 6a is lossless, and the corresponding inverse lossless processing shown in figure 6b is also lossless. Thus it is possible to nest this processing. For example, the 'Lossless Processing' shown on the right of figure 6a could include a PMQ of the sort shown on the left of figure 6a, and the coding effect of this nested PMQ could be inverted by including in the 'Inverse Lossless Processing' shown on the left of figure 6b a PMQ of the sort shown on the right of figure 6b. In this case a bypassed LSB will be generated at each stage, so two bypassed LSBs must be carried round any further processing.

In an MLP encoder there are up to six PMQs in cascade, and any or all of them may be configured to provide a bypassed LSB. Thus the substream may carry up to six bypassed LSBs, one from each PMQ. Although each bypassed LSB comes from a different PMQ, there is no requirement that they come from different channels, and the encoder may occasionally choose to allocate two or more such PMQs to one channel and thus obtain an additional 12dB or more of headroom for that channel.

There are variants of the topology shown in figures 6a and 6b that have an equivalent effect. The subtraction of the signal q in figure 6a and the addition of the signal q in 6b could be interchanged. Subtraction can be avoided by inverting the sign of the coefficients, by inverting the sign of the dither if used, and if necessary by making an adjustment to the quantiser Q , for example by replacing a quantiser that rounds down by a quantiser that rounds up. Another variation is to place the quantiser Q in the forward path, as shown in figure 23a of WO-A 96/37048, instead of in the side-chain, again taking care in choosing quantisers that round up or down. In figure 6b, the shifting of the $S/1'$ signal and the LSB together may instead be implemented as a left shift of the $S/1'$ signal, thereby producing a zero LSB, and then adding the separately transmitted LSB. In this case the addition of the separately transmitted LSB may be

- 22 -

combined with, or performed after, the addition of the quantised signal q . In embodiments for MLP, the addition should produce a 24-bit number.

Figure 8 shows the decoder PMQ specified for MLP, as configured to recover three channels $S1$, $S2$ and $S3$, with the second channel $S2$ being modified. This incorporates some of the variations discussed above and in addition uses a general multiplication to implement the left shift. The encoder specifies the coefficient values and includes them in the stream. Thus, to shift the signal $S2'$ left by one bit the encoder could set the coefficient $m_coeff[2, 2]$ equal to +2. MLP uses 16-bit coefficients in the range $[-2, +2)$; therefore the exact value +2 is not available and the encoder specifies -2 instead. Thus the decoding PMQ inverts the signal in this case and the encoder must also invert the signal to compensate.

As discussed previously, it is advantageous to have two uncorrelated RPDF dither signals in order to furnish two TPDF dither signals by addition and subtraction. In the MLP matrixing, the two 8-bit RPDF dither signals obtained from the sequence generator are sign-extended to 24 bits and treated as if they were two extra channels. These dither channels are never modified by PMQs. It will be seen that the dither in figure 8 is given by:

$$m_coeff[2, 4] \text{ Dither0} + m_coeff[2, 5] \text{ Dither1}$$

This dither is like the dither identified as dither in figure 6b. If $m_coeff[2, 4]$ and $m_coeff[2, 5]$ have the same magnitude, dither will have the desired triangular PDF. Thus, if two PMQs are used to furnish a downmix, the encoder will specify $m_coeff[2, 4]$ and $m_coeff[2, 5]$ with the same sign in one PMQ and opposite signs in the other PMQ, thus furnishing uncorrelated TPDF dither signals by the 'Diamond Dither' method discussed above.

In figure 8 if we regard the input signal samples as 24-bit integers, then the output values from the multipliers will in general have 14 bits after the binary point because the coefficients $m_coeff[2, j]$ may have up to 14 bits after the binary point. We assume for the moment that the quantiser Q_{ss} quantises to a 24-bit integer value. In this case, if the two 8-bit RPDF dither values are right-justified in the 24-bit words Dither0 and Dither1, then the correct magnitudes for $m_coeff[2, 4]$ and $m_coeff[2, 5]$ are 2^{-8} .

If additional PMQs are used to reduce the bit rate of the stream without affecting the downmix signals, it will be normal in the encoder not to use dither, hence the $m_coeff[i, j]$ values used to multiply the dither channels in the PMQs will be zero. This suggests that an economy

- 23 -

could be made by not including the dither capability in all PMQs. This economy is not made in MLP implementations, however, because the advantages realized from the regularity of the structure in practical embodiments far outweighs the cost of an additional pair of multiplications.

In MLP, cascaded PMQs according to figure 8 are used both for Matrix 0 and Matrix 1. In the case of Matrix 1, it would be normal for the coefficient of the channel being modified, which is $m_coeff[2, 2]$ in the case illustrated, to have the value -2 when the LSB bypass is used, and either $+1$ or -1 when the LSB bypass is not used. This choice is made by the encoder and the coefficient is included in the stream for use by the decoder.

When using the 2-channel decoder to reproduce a downmix, Matrix 0 provides the matrixing and/or scaling of the m_0 and m_1 signals to provide L_0 and R_0 . General coefficients, not restricted to powers of two, are then required in the PMQs. Again regularity in the decoder and flexibility for the encoder are reasons for adopting the architecture of figure 8 uniformly.

In Matrix 0, scaling of the modified channel can be accomplished by scaling all the coefficients, except the dither coefficients, that contribute to it. If scaling up is required, there is a possibility that the required scaling will exceed the available coefficient range of $[-2, 2)$, or that signal overload will occur within the matrixing. This can be dealt with by reducing the scaling by a power of 2, then using the final "output_shift" to restore the desired level.

In MLP with downmix, it is not normal to carry the bypassed LSBs in the first substream, Substream 0, since the downmix decoder does not attempt lossless reproduction. The second substream, Substream 1 carries all the information required for the multichannel decoder's matrixing, including the coefficients, the dither seed, and the bypassed LSBs including those LSBs that were dropped from channels that are carried in substream 0.

One feature of figure 8 that does not affect the above discussion is that the quantiser Q_{ss} is able to quantise to a step-size that is a power of 2, thus putting the truncation point one or more bits above the LSB. This facility is included in order to optimise the treatment of input signals that do not exercise the least significant bit(s) of the 24-bit word. In MLP, the LSB bypass feature is used only when the quantisation step size is set to unity.

Stream integrity and 'Lossless Check'

A lossy coding system generally furnishes an output that is not an exact reconstruction of the input signal. Integrity checking, for example a cyclic redundancy check (CRC) or a parity check, should be restricted to a check of the encoded stream so that transmission errors may be flagged. The relationship between the input signal and its final reconstruction is somewhat unknown, being affected both by inherent losses in the lossy encoding and decoding process, and by platform-related errors caused by the arithmetic behaviour of the decoding processor possibly being different from that of the encoding processor.

In MLP, a parity word known as a 'Lossless Check' value, is computed for each segment of the input signal, and included in the encoded stream. It is expected that a decoder will compute a similar parity word and indicate an error has occurred if this computed word does not match the word included in the stream. Unlike the checks that are possible in a lossy coding system, the checks made in a lossless coding system are able to show failures due to overload or other algorithmic failures within the algorithm, platform-related inconsistencies and transmission errors.

In preferred embodiments, a player is able to inform the user of such errors: for example a "Lossless" light could be illuminated when the two check words agree and be extinguished otherwise. Since failure could be momentary, a pulse-stretching circuit may be used so that the user has time to recognize the failure, for example the light could be extinguished for two seconds on receipt of a single failure.

In MLP the Lossless Check value is an 8-bit parity word that is computed for all channels and all samples within a segment of, typically, 1280 words. In terms of the MLP specification, this segment includes all samples between two consecutive 'Restart points'. As MLP assumes 24-bit words, the parity would naturally be computed as a 24-bit word, but this parity word is divided into three octets or bytes and these are exclusively-ORed together in order to furnish the Lossless Check value. Before computing the parity, each 24-bit signal word is rotated by a number of bits equal to its channel number. This rotation avoids a problem where an error that affects two channels identically would otherwise not be detected.

An alternative implementation is to take the parity of all the octets within each segment of

- 25 -

each channel to produce an 8-bit parity octet, and rotate each parity octet by its channel number before exclusively-ORing them together. This may be more economical on processors not having a 24-bit word length.

In MLP with a single substream, the Lossless Check value relates to the original signal that is being losslessly reproduced. When MLP is carrying a downmix, the second substream carries the Lossless Check value relating to the original signal, and this will be checked by a multichannel decoder.

In this downmix case the first substream also carries a Lossless Check value, but this relates only to the downmix. Although the downmix output is not a lossless reproduction of an original signal, it is determinable by virtue of the precise specification of the quantisations in Matrix 0 and the precise specification of the dither. Therefore, the encoder can determine the downmix that will be reproduced by a decoder, and can compute the 'lossless check' value from this simulated downmix. In the context of DVD-Audio mastering, it is intended that the encoder should make the simulated downmix available for auditioning, therefore the listener can be assured that the signal recovered in his player is bit-for-bit identical to the signal heard by the mastering engineer or the recording producer.

An exception arises in the case of overload, which as described above is normally handled by clipping or limiting in the player. Because the behaviour of the clipping or limiting is not precisely defined, the Lossless Check value is computed from the signal immediately prior to any saturation or limiting. In MLP, where as explained above the decoder incorporates a shifter after the final PMQ, and may implement clipping by storing an accumulator to memory using saturation arithmetic, the Lossless Check may be computed directly from the value in the accumulator, which is thereby not affected by the saturation.

Sometimes, as shown in figure 9, a lossless encoder may be preceded by a prequantiser in order to reduce the transmitted data rate. Additional information pertaining to prequantisation may be obtained from the AES 1997 and AES 1998 references cited above. In these situations, the reproduction of the original signal received by the prequantiser will not be lossless but the reproduction of the prequantised signal will be lossless. Again, the prequantised signal should be made available for auditioning and the Lossless Check value should be computed from the prequantised signal so that the listener can be assured that the signal recovered in his player is

- 26 -

bit-for-bit identical to the signal that was auditioned or at least was available for audition, at the mastering stage.

Encoder matrix choice strategies

To encode a two-channel downmix, the signals m_0 and m_1 must be in the subspace spanned by the downmix channels L_0 and R_0 . There is considerable flexibility within this criterion, but some choices are better than others. The encoder should avoid choosing m_0 and m_1 to be nearly linearly dependent for several reasons. Firstly, the matrix M would then probably have large coefficients and the recovery of the downmix would be noisy. Secondly, in solving the equations to determine the PMQs comprised in Matrix 1 the encoder would probably generate coefficients larger than the admissible range. Thirdly, matrixing of the signals affects the data rate for lossless compression, and it is inefficient to transmit separately signals that are very similar to each other.

As noted previously, one way to avoid the worst of these problems is to choose m_0 and m_1 to be orthogonal to each other. That is, m_0 and m_1 are defined in terms of the input signals by a matrix whose rows are orthogonal to each other. This criterion still leaves some flexibility, which could be resolved for example by taking m_0 proportional to L_0 . Consider for example the downmix specification:

$$\begin{bmatrix} L_0 \\ R_0 \end{bmatrix} = \begin{bmatrix} .75 & 0 & .75 & -.126825 & -.5 & .5 \\ 0 & .75 & -.126825 & .8 & -.5 & .5 \end{bmatrix} \begin{bmatrix} L_f \\ R_f \\ L_s \\ R_s \\ C \\ L_{fe} \end{bmatrix}$$

Here the largest coefficient contributing to L_0 is that of L_f , which has a value equal to 0.75. Therefore, if we generate m_0 equal to L_0 scaled by $1/0.75 = 1.333$, we have:

- 27 -

$$m_0 = [1.0000, 0., 1.0000, -.1691, -.6667, .6667] \begin{bmatrix} L_f \\ R_f \\ L_s \\ R_s \\ C \\ L_{fe} \end{bmatrix},$$

which can be implemented by a PMQ that leaves the first channel unmodified.

Signal m_1 must be a linear combination of L_0 and R_0 . A linear combination that is orthogonal to L_0 and hence also orthogonal to m_0 is given by

$$m_1(\text{unscaled}) = R_0 - \lambda L_0,$$

where $\lambda = \frac{R_0 \bullet L_0}{L_0 \bullet L_0}$ and

the symbol \bullet denotes the scalar or dot product of two vectors.

The resulting value is equivalent to taking the dot products of the row vectors in the downmix matrix. If we use *downmix* to denote the downmix matrix, then the scalar λ may be expressed as

$$\lambda = \frac{\text{downmix}_2 \bullet \text{downmix}_1}{\text{downmix}_1 \bullet \text{downmix}_1}$$

where *downmix*₁ denotes the first row vector of the matrix;

*downmix*₂ denotes the second row vector of the matrix; and

Using the downmix matrix from the example shown above, $\lambda = 0.1849$. Thus:

$$m_1(\text{unscaled}) = [-.1387, .7500, -.2655, .8234, -.4076, .4076] \begin{bmatrix} L_f \\ R_f \\ L_s \\ R_s \\ C \\ L_{fe} \end{bmatrix}.$$

The second PMQ that will generate m_1 , receives the signals furnished by the first PMQ, the first channel of which is m_0 rather than L_f . Therefore m_1 must be re-expressed in terms of m_0 , R_f etc.:

- 28 -

$$m_1(\text{unscaled}) = [-.1387, .7500, -.1268, .8000, -.5000, .5000] \begin{bmatrix} m_0 \\ R_f \\ L_s \\ R_s \\ C \\ L_{fe} \end{bmatrix}.$$

Here the largest coefficient, 0.8000, multiplies R_s , the fourth input channel. Therefore we apply a permutation, as discussed previously, to swap the second and fourth input channels and thus bring R_s to the second position so that m_1 will appear in the second position in the matrix output:

$$m_1(\text{unscaled}) = [-.1387, .8000, -.1268, .7500, -.5000, .5000] \begin{bmatrix} m_0 \\ R_s \\ L_s \\ R_f \\ C \\ L_{fe} \end{bmatrix}.$$

Finally we scale so that the coefficient of R_s is unity:

$$m_1 = [-.1733, 1.0000, -.1585, .9375, -.6250, .6250] \begin{bmatrix} m_0 \\ R_s \\ L_s \\ R_f \\ C \\ L_{fe} \end{bmatrix}.$$

This is now in the correct form for implementation by a second PMQ.

The above example shows one of several strategies that can be adopted by an encoder. A simpler strategy is to compute m_0 as above, then to define m_1 , apart from scaling, by subtracting a proportion λ of L_0 from R_0 such that the coefficient of L_f is zero. In this particular example, the sparsity of the original downmix specification results in this condition being satisfied with $\lambda = 0$:

- 29 -

$$m_1(\text{unscaled}) = [0., .7500, -.1268, .8000, -.5000, .5000] \begin{bmatrix} L_f \\ R_f \\ L_s \\ R_s \\ C \\ L_{fe} \end{bmatrix}$$

The zero value of the first coefficient avoids the need, when calculating the second PMQ, to consider the effect of the first PMQ. That is, m_0 can be substituted for L_f in the above equation without making any other change. Applying scaling and permutation as discussed previously, we obtain:

$$m_1 = [0., 1.0000, -.1585, .9375, -.6250, .6250] \begin{bmatrix} m_0 \\ R_s \\ L_s \\ R_f \\ C \\ L_{fe} \end{bmatrix},$$

which is of the correct form for implementation by the second PMQ.

Although the above simplified procedure does not achieve orthogonality, it does avoid generating m_0 and m_1 that are nearly linearly dependent, for example if L_0 and R_0 themselves were nearly linearly dependent. The possibility that L_0 and R_0 are actually linearly dependent (i.e. are scaled versions of each other) must be tested for and treated as a special case.

Alternatively, in a more advanced encoder, the above orthogonality condition can be replaced by the condition that the cross-correlation of the signals m_0 and m_1 should be approximately zero. This condition can be satisfied by an appropriate choice of λ . The condition of zero cross-correlation minimises the energy in m_1 , and in the absence of frequency dependence this would be effective in minimising the transmitted data rate. As explained in WO-A 96/37048, data rate in the presence of spectral variation is more dependent on information content than on energy. With typical audio signals, the energy and cross-correlation will be dominated by large low-frequency signals, which have little information content on account of their low bandwidth. Hence it is better to apply a spectral weighting, which will typically

- 30 -

emphasise high frequencies, before calculating cross correlation. Ideally the spectral weighting will be adapted to the signal itself, but it is complicated to determine an optimal or near-optimal weighting, and in practice a fixed weighting will suffice. For example, a digital filter whose z -transform is

$$(1 - z^{-1})^2$$

will have a response rising at 12dB per octave over the low and mid-frequency part of the audio band, and this will generally be sufficient to suppress undue domination by large low-frequency signals.

In WO-A 96/37048, the preferred directions for the transmitted signals was disclosed as being the eigenvectors of a matrix that, in the absence of frequency-dependence, would have been the correlation matrix of the signals. Such a choice would lead to zero correlation between the transmitted signals. However computation of eigenvectors is time consuming, and the procedure outlined above wherein the zero correlation is achieved simply by subtraction leads to a data rate that theoretically differs little from that resulting from an eigenvector computation.

The procedures above for choosing the directions of the transmitted signals can also be applied generally, that is to encoders that do not compute a downmix, or to the processing of the remaining channels once a downmix has been extracted.

We now describe a procedure in which the vector directions of the transmitted channels are chosen one by one. A first input channel is chosen, and other channels are subtracted from it with coefficients chosen to minimise the energy in the signal remaining after the subtraction. A primitive matrix quantiser implements the subtraction and furnishes an output signal. Then another input channel is chosen, and again the other channels are subtracted by a PMQ. The PMQ furnishes the next output signal and has coefficients chosen to minimise the energy therein. The process is repeated until all input channels have been processed, or until all available PMQs have been used, or until it is considered not worth applying further matrix transformations. Any further input channels that have not been modified by PMQs are passed to the output without modification.

An improvement on this procedure would be to choose the subtraction so as to minimise some measure of entropy, or information content, of the signal rather than simply to minimise the energy. In WO-A 96/37048, the entropy was estimated by taking the integral over frequency of

- 31 -

the logarithm of the spectrum, and it would be entirely possible to compute each minimisation with respect to this criterion. Minimisation of spectrally-weighted energy would be a less computationally-intensive alternative, and there are various ways of computing an appropriate spectral weighting in dependence on the signal. More economical still would be the use of a fixed frequency weighting, for example as provided by a digital filter having z -transform $(1 - z^{-1})^2$.

It will be recognised by those skilled in the art of numerical matrix algebra that the above process is somewhat akin to the use of Gram-Schmidt Orthogonalisation to furnish an orthogonal set of vectors. By analogy it might be considered unnecessary, when considering the subtraction, to include vectors that have already been processed, since they are by construction orthogonal to the vectors that have not yet been processed. However this will not generally be true when a downmix is being encoded, nor will it be true if the minimisation is of entropy rather than energy. Hence in general, each PMQ will subtract both signals that have already been processed and input channels that have yet to be processed.

So far the order in which channels are chosen for modification has been considered to be arbitrary. In many cases the order may have little effect on the final data rate, but it can substantially affect the size of the coefficients in the subtraction. As MLP restricts coefficients to a maximum value of 2, this consideration is important. If the minimisation is of energy, or of energy with a fixed spectral weighting, this is extremely fast computationally and it is entirely possible to make an arbitrary selection on a trial basis and to reject that and try another if the coefficients are too big. Another heuristic is to choose for modification the channel whose energy, or spectrally weighted energy, is the smallest.

If the PMQ is implemented as in figure 8, it would be normal to choose a coefficient of +1 or -1 for the channel being modified. If the subtraction generates signals that overload, the coefficient may be reduced. It would be normal in MLP to reduce it to -0.5, using the LSB bypass method described above. This will provide an additional 6dB of headroom, which will usually be sufficient. If it is not, there are several possibilities. The currently considered matrix transformation may be modified or abandoned; that is, the input channel may be transmitted without modification. Or, if another PMQ is available, it too may be configured for LSB bypass operation and allocated to the channel under consideration allowing a further 6dB increase in

- 32 -

headroom. The additional PMQ will be applied prior to the PMQ that implements the subtraction. The additional PMQ, being required simply to reduce the signal amplitude, will normally in MLP apply a coefficient of -0.5 to the channel being modified, and have zero coefficients otherwise.

A particular case where two or even three PMQs may be needed to process a channel is where a downmix specification has several coefficients of substantially the same magnitude. For example, although the PMQ that furnishes m_0 in the example above has all coefficients less than unity, the sum of absolute magnitudes of the coefficients is 2.627. Thus, even if the PMQ furnishing m_0 uses LSB bypass and scales the channel by 0.5, there is still a possibility of an increase in signal magnitude of a factor 1.313. This can happen if, on a given sample period, channels of the input achieve full modulation simultaneously and each has the same sign as its coefficient in the PMQ, or if each has the opposite sign as its coefficient. Overload can be avoided by allocating an additional PMQ implementing an LSB bypass prior the PMQ that furnishes m_0 .

For clarity, the above description mentions only the PMQs implemented by the encoder. It will be understood that for each PMQ it uses, the encoder must specify a corresponding PMQ to be used in Matrix 1 by the lossless decoder, and that the decoder's PMQs must be applied in reverse order. In the case of LSB bypass, an encoder PMQ applying a coefficient of -0.5 to the channel being modified implies a decoder PMQ applying a coefficient of -2.0 to that channel. In the downmix case, the encoder must specify the coefficients for Matrix 0 in dependence on the choices made for m_0 and m_1 . Further, if a channel has been scaled, the scaling factor must be taken into account in calculating subsequent downmix coefficients that will multiply the channel.

Encoding of mixed-rate content

The DVD-Audio specification allows for a recording to be carried on the disc using two sampling frequencies. For example, the frontal channels L_f , R_f may be encoded at 96kHz sampling rate, while the other channels may be encoded at 48kHz in order to reduce the data rate. However, the preceding description of the simultaneous transmission of downmix information in

a first substream assumes that the channels are all sampled simultaneously and, in particular, at the same sampling rate.

The article P.G. Craven, M.J. Law J.R. and Stuart, 'Lossless Compression using IIR Prediction Filters', *J. Audio Eng. Soc.*, Abstracts, March 1997, vol. 45, no. 5, p. 404 preprint no. 4415 explains that, when using lossless compression, it is not necessary to reduce the sampling rate in order to save data. It is sufficient to restrict the bandwidth of the signal because the lossless encoder will automatically respond to the reduction in information content of the signal and encode it to a lower bit rate.

An upsampled signal inherently has a restricted bandwidth. For example, a 96kHz sampled signal has the ability to reproduce frequencies up to nearly 48kHz, but such a signal will have very little energy above 24kHz if it is derived by upsampling a 48 kHz sampled signal. Accordingly, when lossless compression is used on 'mixed-rate' material, it is possible, without significant adverse effect on the data-rate, to 'upsample' any channels that are presented at a lower rate, e.g., 48kHz, before encoding so that all channels are encoded at the same sampling rate, e.g., 96kHz. This unified sample rate makes possible the matrix operations required in order to implement the invention.

'Upsampling' is also known as 'interpolation' in the Digital Signal Processing literature, and the techniques for performing it are well known. Figure 10 shows an encoder adapted to include this feature. As filtering involves delay, the channels L_f and R_f that do not require upsampling are given a compensating delay.

Interpolation filtering is in general not lossless, but in a preferred embodiment the 'upsample' filters in figure 10 are of the type known as 'half band filters'. When used for interpolation, half-band filters furnish an output with twice as many sampling points as the input sampling points. The even-numbered output points correspond to the input points and contain sample values identical to the input values, while the odd-numbered output points lie half way between the input values and contain interpolated values.

When a stream is encoded in this way, the player has two options. It may play the stream as if all the channels were originally sampled at 96kHz, thus ignoring the differing provenance of even and odd samples. Alternatively the player may select only the even samples in the case of channels that were originally presented to the encoder at 48kHz. In this case the player has

- 34 -

access to a lossless reconstruction of the mixed-rate content that was presented to the encoder. In order to make this possible, the encoded stream must contain a specification of which channels were originally presented at the lower sampling rate, and an indication of which samples are to be regarded as 'even' and which are to be regarded as 'odd'. The latter may be implicit if the stream contains a block structure in which the number of samples in a block is always even. On DVD-Audio, the use of 'Access Units' and 'Presentation Units' provides such a structure.

The DVD-Audio specification provides similarly for mixed-rate content at 88.2kHz and 44.1kHz. The mixed-rate coding feature described above may also be applied to this case in a similar manner.

Implementation

The functions required to practice various aspects of the invention can be performed by components that are implemented in a wide variety of ways including discrete logic components, one or more ASICs and/or program-controlled processors. The manner in which these components are implemented is not critical. For example, operations required to practice these aspects of the invention can be implemented by in an apparatus that comprises one or more terminals for receiving and sending signals representing digital information, random access memory for storing the digital information, a medium for recording one or more programs of instructions, and a processor that executes the programs of instructions. The programs of instructions may be recorded by a variety machine readable media or other products of manufacture including various types of read-only memory, magnetic tape, magnetic disk, optical disc, or conveyed by baseband or modulated communication paths throughout the spectrum from supersonic to ultraviolet frequencies.

Various features of the encoding and decoding processes and apparatus have been described above. It is to be understood that, where these features can be implemented separately, it is envisaged that these features may be brought together in any combination, in order to benefit from the different advantages provided by those features. While the claims define various features independently, the features of all claims can be combined with each other and this

disclosure is intended to include all such combinations.

A0/26146 WO EP (DOL06505 PCT)

PCT/GB00/01308

- 36 -

CLAIMS

1. A decoder comprising:
 - an input for a number N of encoded input channels,
 - 5 a matrix for transforming the input channels and implemented as a cascade of primitive matrix quantisers, the matrix providing the number N of matrix output channels,
 - a re-mapping arrangement arranged such that a number N of decoder output channels are ordered in response to channel ordering information derived from the input channels.
- 10 2. A decoder as claimed in claim 1, wherein the re-mapping arrangement is provided after the matrix.
- 15 3. A decoder as claimed in claim 1, wherein the re-mapping arrangement is provided before the matrix.
- 20 4. A decoder as claimed in claim 1, wherein the number N is six, and the encoded channels comprise the left-front, right-front, left-surround, right-surround, centre and low-frequency-effects channels of a six channel audio signal.
- 25 5. An encoder comprising:
 - a number N of input channels;
 - a reordering arrangement for permuting the channels;
 - 25 a matrix for transforming the input channels and implemented as a cascade of primitive matrix quantisers, the matrix providing the number N of matrix output channels as a stream of encoded information formatted as a plurality of substreams, the data in the first substream comprising a strict subset of the outputs of the matrix and containing sufficient information for
 - 30 implementation of a downmix specification; and
 - means for encoding the selected permutation into the encoded output stream.

A0/26146 WO EP (DOL06505 PCT)

PCT/GB00/01308

- 37 -

6. An encoder as claimed in claim 5, wherein the reordering arrangement is responsive to the downmix specification.

5 7. An encoder as claimed in claim 5 providing lossless compression, and further comprising at least one primitive matrix quantiser that modifies a channel that is not fed to the first substream, wherein the coefficients of that primitive matrix are chosen with the object of reducing the data rate of the encoded stream.

10 8. A computer memory product having stored thereon an encoded audio data signal, the encoded audio data signal comprising a number N of encoded audio channels which have been encoded by a matrix transformation, the encoded audio data further comprising channel ordering information, wherein the channel ordering information is provided for causing reordering of the channels at the input or output of a matrix transformation unit of a decoder for decoding the audio data.

15

9. An encoded audio data signal provided on a carrier, the encoded audio data signal comprising a number N of encoded audio channels which have been encoded by a matrix transformation, the encoded audio data further comprising channel ordering information, wherein the channel ordering information is provided for causing reordering of the channels at the input or output of a matrix transformation unit of a decoder for decoding the audio data.

20

10. A method of encoding a number N of input channels comprising:
permuting the channels;
25 applying a matrix transformation to the reordered input channels using a cascade of primitive matrix quantisers, the matrix providing the number N of matrix output channels as a stream of encoded information formatted as a plurality of substreams, the data in the first substream comprising a strict subset of the outputs of the matrix and containing sufficient information for
30 implementation of a downmix specification; and
encoding the selected permutation into the encoded output stream, wherein the permutation of the channels takes into account the downmix specification.

A0/26146 WO EP (DOL06505 PCT)

PCT/GB00/01308

- 38 -

11. A method of decoding a number N of input channels, the method comprising:
applying an inverse matrix transformation to the input channels using a
cascade of primitive matrix quantisers, the matrix providing the number N of
matrix output channels;
5 obtaining channel ordering information from the encoded input channels;
and
permuting the matrix output channels in dependence on the channel
ordering information.
12. A decoder comprising:
an input for an encoded stream comprising a plurality of encoded
channels;
at least a first primitive matrix quantiser that modifies a first channel;
a multiplier for multiplying the first channel by a gain coefficient; and
15 a combiner for combining the multiplied first channel signal with
additional least significant bits recovered from the encoded stream,
wherein the gain coefficient is selectable by the decoder based on information in the
encoded stream, and may take a number of values including one or more values which are
not powers of two.
13. A decoder as claimed in claim 12, wherein the modified first channel is a
linear combination of the channels input to the primitive matrix quantiser.
14. A decoder as claimed in claim 12, wherein the combiner comprises an adder.
15. An encoder for encoding a plurality of channels, the encoder comprising:
at least a first primitive matrix quantiser that modifies a first channel ;
a multiplier for multiplying the first channel by a gain coefficient within
the first primitive matrix quantiser;
25 means for recovering any least significant bits which result from the
multiplication which exceed a number of bits allocated to the channel; and
means for storing the recovered least significant bits, the multiplied
modified first channel and a parameter representing the gain coefficient to enable
30

A0/26146 WO EP (DOL06505 PCT)

PCT/GB00/01308

- 39 -

future decoding, wherein the gain coefficient may take a number of values including one or more values which are not powers of two.

5 16. A computer memory product having stored thereon an encoded audio data signal, the encoded audio data signal comprising a number N of encoded audio channels which have been encoded by a matrix transformation, the encoded audio data further comprising a parameter indicating a gain coefficient for at least one channel, and the encoded audio signal further comprising additional least significant bits for the at least one channel, wherein the gain coefficient is provided for causing multiplication of the
10 channel within a matrix transformation unit of a decoder for decoding the audio data, and the additional least significant bits are provided for combination with the multiplied channel, and wherein the gain coefficient and may take a number of values including one or more values which are not powers of two.

15 17. A computer memory product as claimed in claim 16, wherein $N=6$.

18. An encoded audio data signal provided on a carrier, the encoded audio data signal comprising a number N of encoded audio channels which have been encoded by a matrix transformation, the encoded audio data further comprising a parameter indicating a
20 gain coefficient for at least one channel, and the encoded audio signal further comprising additional least significant bits for the at least one channel, wherein the gain coefficient is provided for causing multiplication of the channel within a matrix transformation unit of a decoder for decoding the audio data, and the additional least significant bits are provided for combination with the multiplied channel, and wherein the gain coefficient
25 may take a number of values including one or more values which are not powers of two.

19. A method of decoding an encoded stream comprising a plurality of encoded channels, the method comprising:

30 applying an inverse matrix transformation to the input channels using a cascade of primitive matrix quantisers, a first primitive matrix quantiser being used to modify a first channel;

within the first primitive matrix quantiser, multiplying the first channel by a gain coefficient derived from information in the encoded stream; and

A0/26146 WO EP (DOL06505 PCT)

PCT/GB00/01308

- 40 -

combining the multiplied first channel signal with additional least significant bits recovered from the encoded stream, wherein the gain coefficient may take a number of values including one or more values which are not powers of two.

5

20. A method as claimed in claim 19, wherein the combining comprises adding.

21. A method of encoding a plurality of input channels, the method comprising:
applying a matrix transformation to the input channels using a cascade of primitive matrix quantisers, a first primitive matrix quantiser being used to modify a first channel;

10

within the first primitive matrix quantiser, multiplying the first channel by a gain coefficient;

15

recovering any additional least significant bits which result from the multiplication which exceed a number of bits allocated to the channel; and storing the additional least significant bits, the multiplied modified first channel and a parameter indicating the gain coefficient to enable future decoding, wherein the gain coefficient may take a number of values including one or more values which are not powers of two.

20

22. An encoder apparatus for a lossless compression system furnishing an encoded compressed stream having at least two substreams, one of which provides a two-channel downmix signal and the other provides a multichannel digital signal, the encoder comprising:

25

an input for the multichannel digital signal;
an input for receiving a specification for the two-channel downmix signal;
and

30

means for computing a first check value relating to a portion of downmix signal and inserting the first check value in a first substream and for computing a second check value relating to a portion of the multichannel signal and inserting the second check value in a second substream.

23. An encoder apparatus as claimed in claim 22 further comprising a downmix signal output enabling the downmix signal to be auditioned.

AMENDED SHEET

A0/26146 WO EP (DOL06505 PCT)

PCT/GB00/01308

- 41 -

24. A decoder apparatus for decoding a losslessly compressed encoded signal, the decoder comprising:

- 5 an input for a multichannel encoded digital signal;
 means for computing a first check value relating to a portion of the multichannel signal,
 means for retrieving a second check value from the encoded stream relating to said portion of the multichannel signal;
 a comparator arrangement for comparing the first and second check
10 values; and
 an output device for providing a flag indicating whether the check values agree.

25. An apparatus as claimed in any one of claims 22 to 24 comprising a digital
15 signal processor for implementing each computation of a check value as a bitwise parity operation on the binary representations of the signal words in a segment of the signal, the binary words being rotated in dependence on the channel number before the parity is computed.

20 26. A player for a consumer disc comprising a decoder according to claim 24, wherein the output device comprises a visible indicator, and wherein the player further comprises a pulse-stretching circuit for providing a drive signal for the visible indicator, configured such that a lack of agreement between the first and the second check values for a time period shorter than a threshold level results in a visible indication for a time
25 period longer than the threshold level.

27. An apparatus comprising an encoder as claimed in claim 22 and a prequantiser, the encoder providing as outputs an encoded compressed stream and a prequantised signal that can be auditioned, wherein the check value inserted in the
30 compressed stream is computed from the prequantised signal.

28. A two-channel lossless decoder receiving as input an encoded stream, the decoder comprising:

A0/26146 WO EP (DOL06505 PCT)

PCT/GB00/01308

- 42 -

a decoder core to which the stream is supplied to generate a two-channel decoded signal;

a shifter at the output of the decoder core for applying an arithmetic shift in response to information in the encoded stream; and

5 a signal limiting device at the output of the shifter, the shifter and the limiting device providing limitation of the wordwidth at the output of the decoder.

29. A decoder as claimed in claim 28, wherein the encoded input stream comprises at least two substreams, which together define a multi-channel encoded audio
10 signal having more than two channels, and wherein one of the substreams is supplied to generate the two-channel decoded signal.

30. A decoder as claimed in claim 28 or 29 wherein the limiting device comprises a clipper which stores the output of the arithmetic shift using saturation
15 arithmetic.

31. An encoder comprising:

an input for receiving a multi-channel signal having a first input channel or channels sampled at a first rate and a second input channel or channels sampled
20 at a higher rate equal to twice the lower rate;

a device for increasing the sampling rate of the or each first input channel to the higher rate; and

a lossless encoder which receives the first and second channels at the higher rate, for generating an encoded stream.
25

32. An encoder as claimed in claim 31 further comprising means for inserting sample rate information into the encoded stream indicating, for each decoded channel, whether the corresponding input channel was sampled at the first or at the second rate.

30 33. An encoder as claimed in claim 32, wherein each device for increasing the sampling rate comprises half band filters providing a first plurality of samples corresponding to the input signal and a second plurality of interpolated samples.

A0/26146 WO EP (DOL06505 PCT)

PCT/GB00/01308

- 43 -

34. An encoder as claimed in claim 33, wherein the means for inserting sampling rate information indicates which decoded samples correspond to the input signal.

5 35. An encoder as claimed in any one of claims 31 to 34 further comprising delay elements in the signal paths of the higher rate channels that substantially compensate the delays introduced by the sample rate increase of the lower rate channels.

10 36. A decoder comprising an input for an encoded stream produced by the encoder of claim 33 or 34 and furnishing a multichannel output, wherein the decoded samples of the lower-rate channels that do not correspond to original samples of the input channels are discarded, thereby furnishing an output identical to the multi-channel signal originally presented to the encoding apparatus.

15 37. A computer memory product having stored thereon an encoded audio data signal, the encoded audio data signal comprising a plurality of encoded audio channels representing channel signals sampled either at a first sampling rate or at a higher second sampling rate which is double the first sampling rate, wherein the encoded audio channels are all sampled at the second higher rate, and wherein additional information is provided for each channel indicating whether the channel signal was sampled at the first or the
20 second rate.

25 38. A computer memory product as claimed in claim 37 wherein the additional information further indicates, for those encoded channels representing channel signals sampled at the first rate, which decoded samples correspond to the input signal.

30 39. An encoded audio data signal provided on a carrier, the encoded audio data signal comprising a plurality of encoded audio channels representing channel signals sampled either at a first sampling rate or at a higher second sampling rate which is double the first sampling rate, wherein the encoded audio channels are all sampled at the second higher rate, and wherein additional information is provided for each channel indicating whether the channel signal was sampled at the first or the second rate.

40. An encoded audio data signal provided on a carrier as claimed in claim 39, wherein the additional information further indicates, for those encoded channels

AMENDED SHEET

A0/26146 WO EP (DOL06505 PCT)

PCT/GB00/01308

- 44 -

representing channel signals sampled at the first rate, which decoded samples correspond to the input signal.

41. An encoder comprising:

5 inputs for a multichannel digital signal and for a downmix specification, comprising; and

10 a matrix implemented as a cascade of primitive matrix quantisers and furnishing a stream of encoded information formatted as a plurality of substreams, the data in the first substream being taken from a strict subset of the outputs of the matrix and containing sufficient information for implementation of the downmix specification; wherein the matrix comprises:

15 a first primitive matrix having terms computed with respect to the specification for a first downmix channel, such that an output of the first primitive matrix is substantially the first downmix channel multiplied by a scaling factor; and

a second primitive matrix having terms computed such that a coefficient multiplying the output of the first primitive matrix is substantially zero.

20 42. An encoder as claimed in claim 41, wherein the first primitive matrix modifies an input channel having substantially the largest coefficient in the specification for the first downmix channel.

43. An encoder comprising:

25 inputs for a multichannel digital signal and for a downmix specification; and

30 a matrix implemented as a cascade of primitive matrix quantisers and furnishing a stream of encoded information formatted as a plurality of substreams, the data in the first substream being taken from a strict subset of the outputs of the matrix and containing sufficient information for implementation of the downmix specification, wherein the matrix defining the channels transmitted in the first substream in terms of the channels of the multichannel signal has rows that are substantially orthogonal to each other.

A0/26146 WO EP (DOL06505 PCT)

PCT/GB00/01308

- 45 -

44. An encoder comprising:

inputs for a multichannel digital signal and for a downmix specification;

and

a matrix implemented as a cascade of primitive matrix quantisers and
5 furnishing a stream of encoded information formatted as a plurality of substreams,
the data in the first substream being taken from a strict subset of the outputs of the
matrix and containing sufficient information for implementation of the downmix
specification, wherein the cross-correlation between the transmitted channels of
the first substream is substantially zero.

10

45. An encoder as claimed in claim 44, wherein said cross-correlation is given a
spectral weighting that emphasises the frequency bands that contribute substantially to the
transmitted data rate.

15

46. An encoder as claimed in claim 45, wherein said cross-correlation is given a
spectral weighting substantially as defined by the digital filter $(1 - z^{-1})^n$, where $n = 1, 2$ or
3.

20

47. In a lossless encoder comprising two or more input channels and transmitting
output signals that are linear combinations of the input channels, a method of determining
the output signals for transmission, comprising the steps of:

(i) establishing a first list of input channels, and a second list defining
output signals determined for transmission;

25

(ii) deleting one channel from the first list and choosing a linear
combination of the remaining channels in the first list and of the output signals
determined for transmission, the linear combination being chosen substantially to
minimise an entropy measure for a difference signal equal to the difference
between said one channel and the linear combination;

30

(iii) applying a scaling factor to the difference signal to obtain a scaled
difference signal;

(iv) allocating the scaled difference signal as an output signal for
transmission, and including a definition of that output signal in the second list;
and

(v) repeating steps (ii) to (iv) for a further input channel or channels.

AMENDED SHEET

A0/26146 WO EP (DOL06505 PCT)

PCT/GB00/01308

- 46 -

48. A method as claimed in claim 47, wherein the definition of the output signal comprises the output signal itself.

5 49. A method as claimed in claim 47, wherein the definition of the output signal comprises matrix specifications enabling the output signal to be calculated.

10 50. A method as claimed in claim 47, wherein the first list is initially equal to the entire set of input channels, and the second list is initially empty.

15 51. A method as claimed in claim 47, wherein the second list initially contains signals that allow a downmix to be recovered, and the first list contains a subset of the set of input channels.

20 52. A method as claimed in claim 47, in which the step of deleting one channel comprises selecting a channel for deletion from the first list for which the absolute magnitudes of the coefficients in the linear combination do not exceed a predetermined limit.

25 53. A method as claimed in claim 47, in which the step of deleting one channel comprises selecting a channel having the smallest energy.

54. A method as claimed in claim 47, in which said scaling factor is +1 or -1.

30 55. A method as claimed in claim 47, in which said scaling factor is $+1/2$ or $-1/2$.

56. A method as claimed in claim 47, in which said entropy measure is energy.

57. A method as claimed in claim 47, in which said entropy measure is energy calculated with a spectral weighting that emphasises the frequency bands that contribute substantially to the data rate of a compressed output stream of the encoder.

- 47 -

58. A method as claimed in claim 47, in which said entropy measure is energy calculated with a spectral weighting substantially as defined by the digital filter $(1 - z^{-1})^n$, where $n = 1, 2$ or 3 .

5 59. A method as claimed in claim 47, in which calculation of the scaled difference signal is performed by a primitive matrix quantiser.

10 60. A method as claimed in claim 47, in which the scaling factor has a magnitude of less than unity, and in which additional least significant bits recovered following the scaling operation are provided as an output signal for transmission.

15 61. A method of encoding two or more channels to produce output signals for transmission that are linear combinations of the input channels, the method comprising:
determining the output signals for transmission using the method of any
one of claims 47 to 60; and
calculating the determined output signals.

20 62. A method of encoding a multichannel signal containing input channels and a downmix specification, comprising the steps of:
choosing a first input channel having substantially the largest coefficient
in the specification of a downmix channel; and
scaling down the first input channel using a primitive matrix quantiser in
which the coefficient of the first channel is less than unity and the coefficients of
the other input channels are substantially zero.

25 63. A method as claimed in claim 62, in which additional least significant bits recovered following the scaling operation are provided as an output signal for transmission.

30

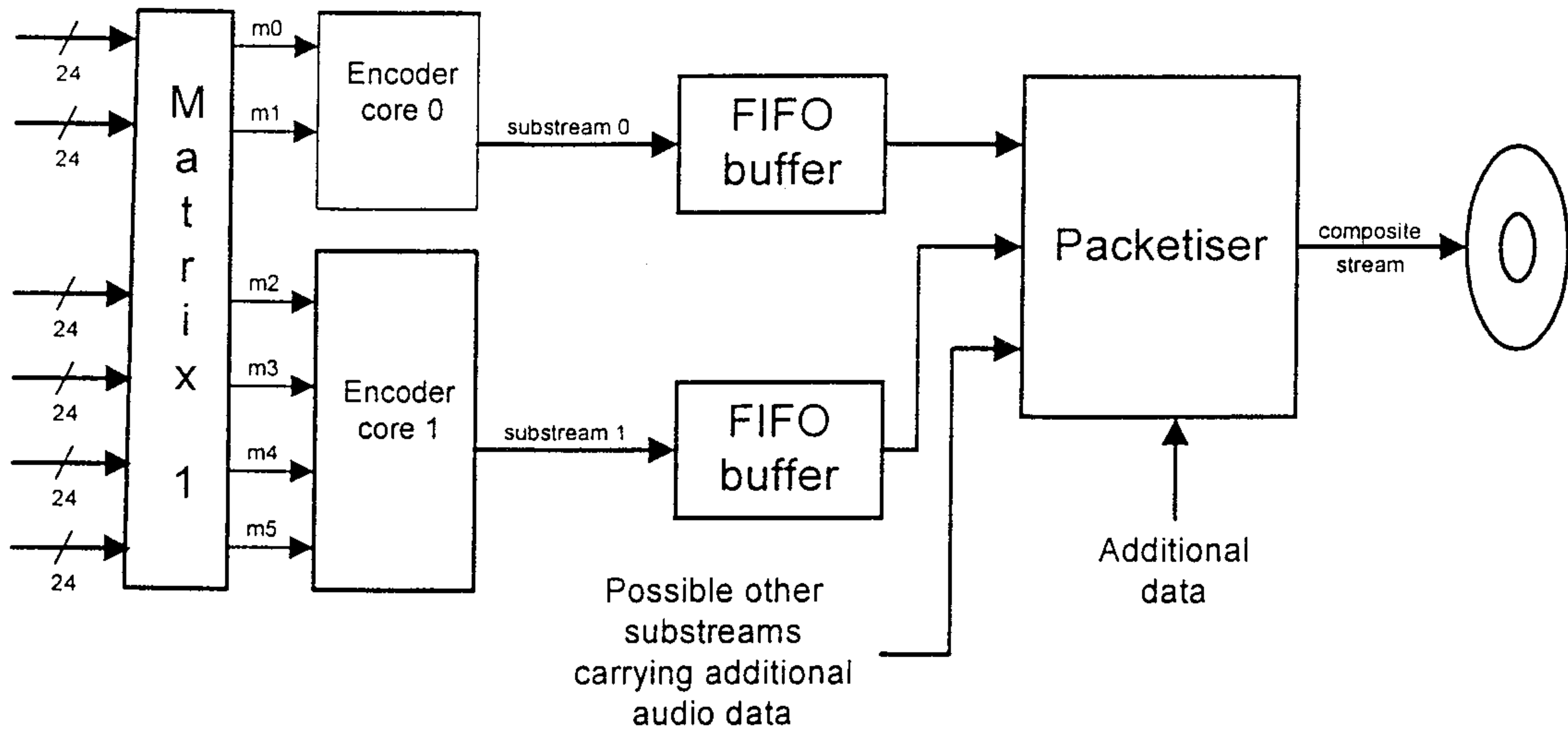

Figure 1

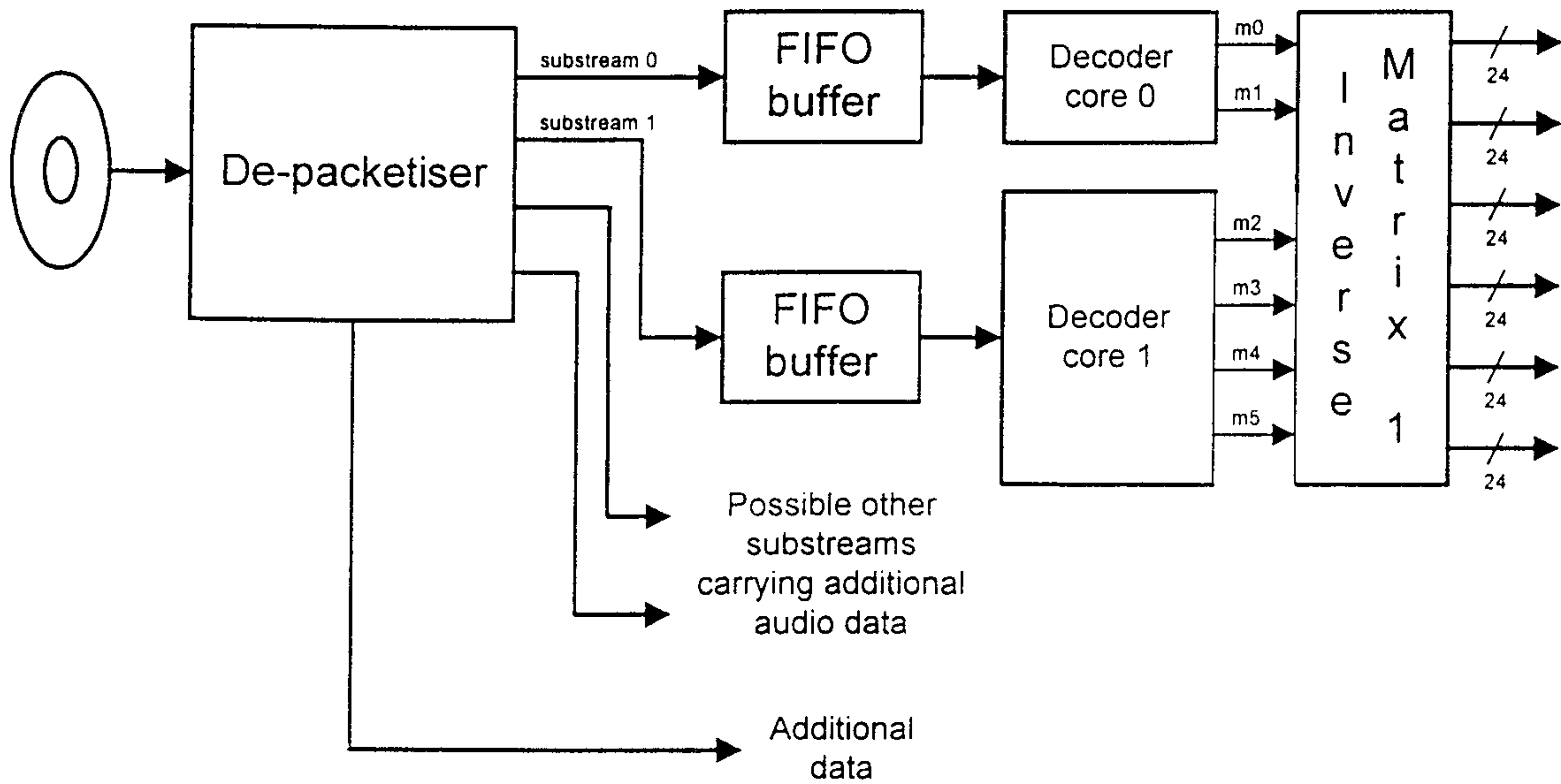

Figure 2

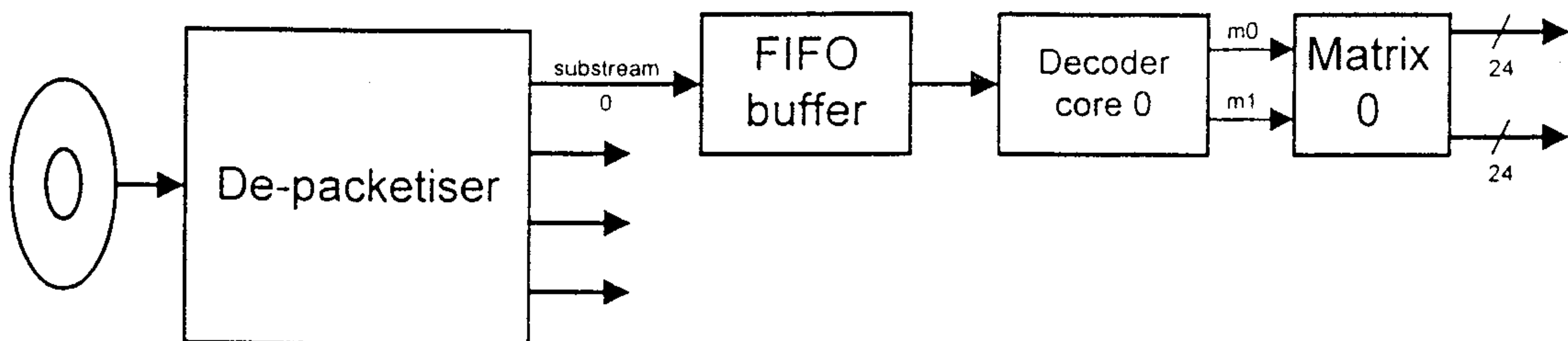

Figure 3

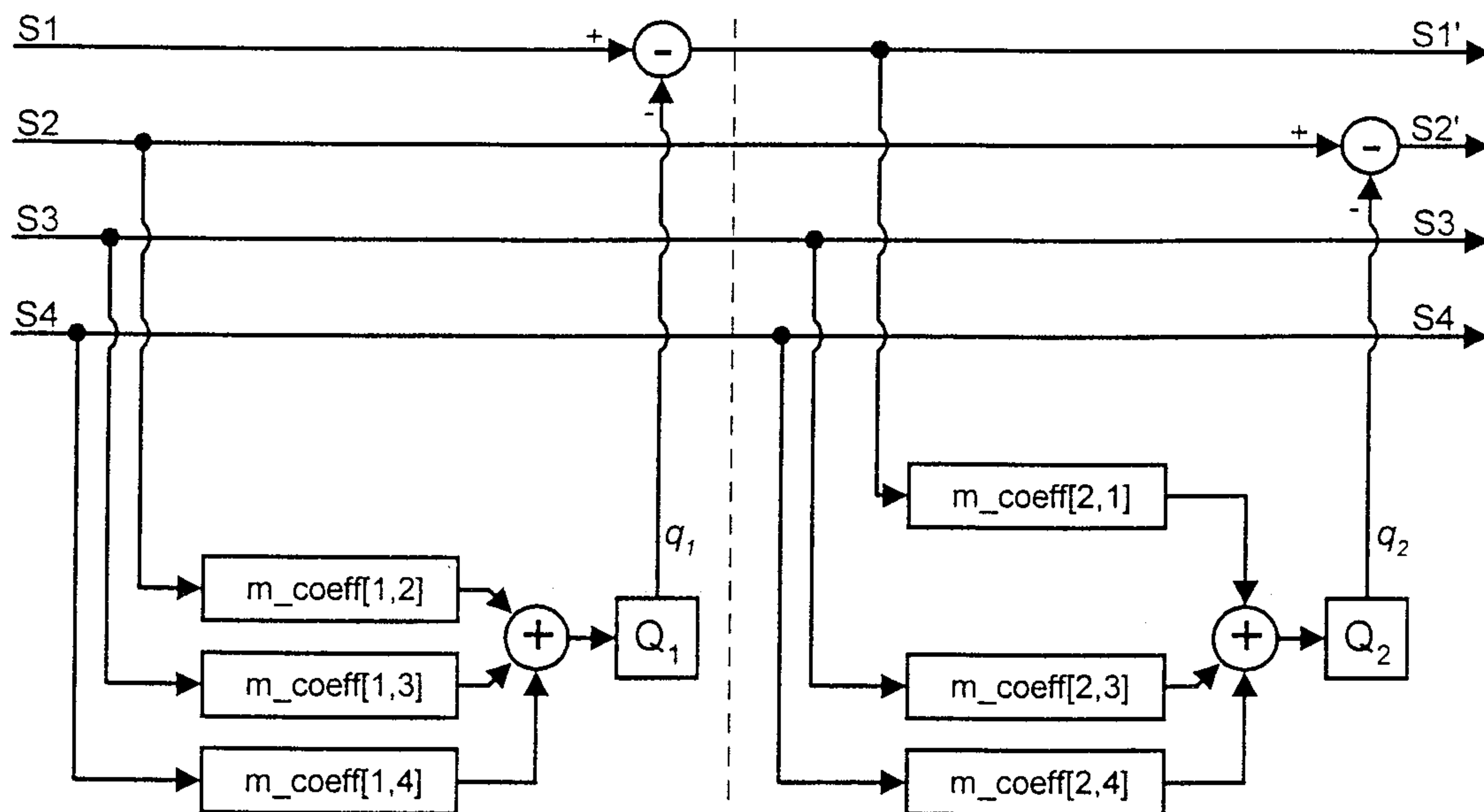

Figure 4a

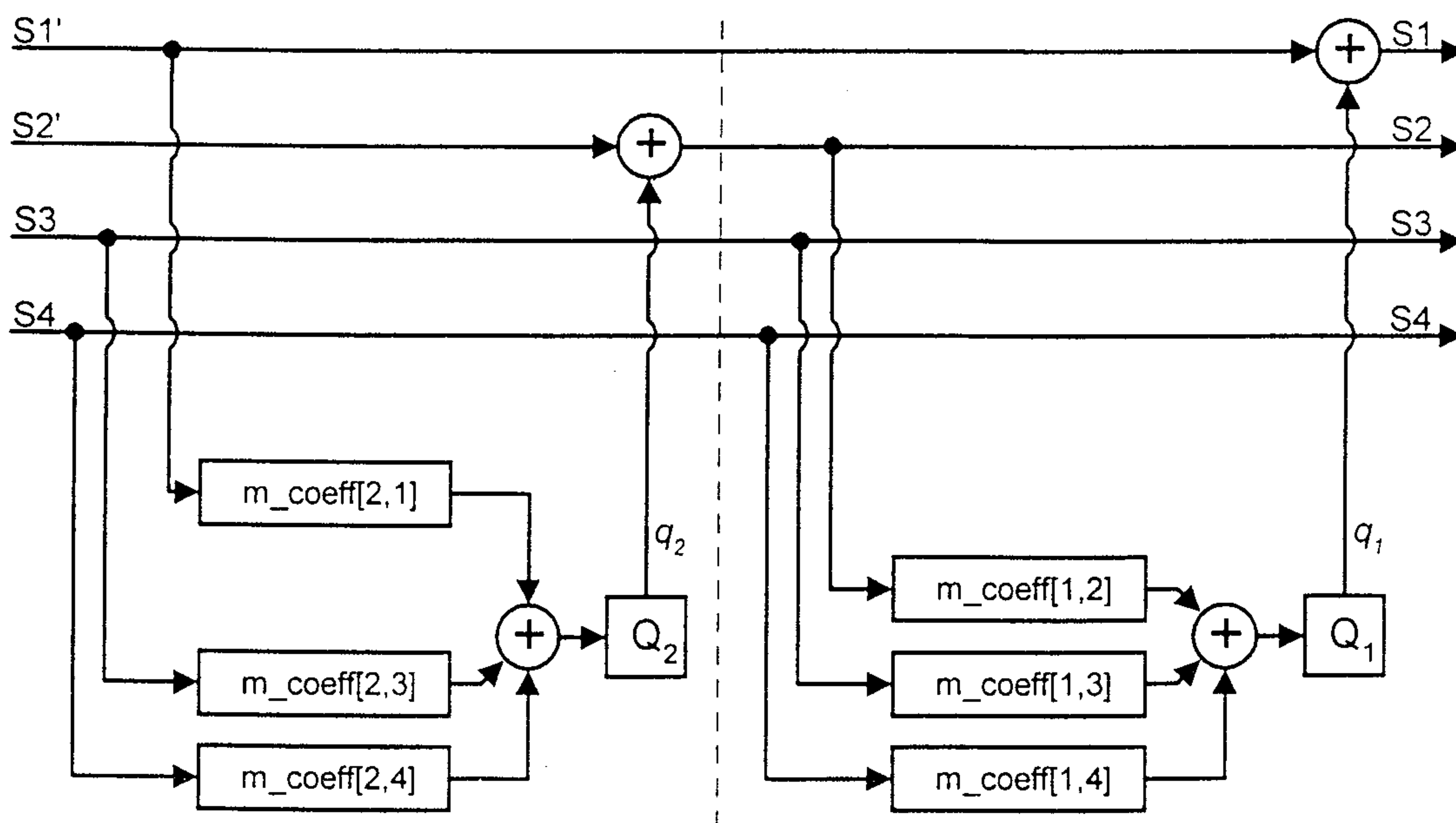

Figure 4b

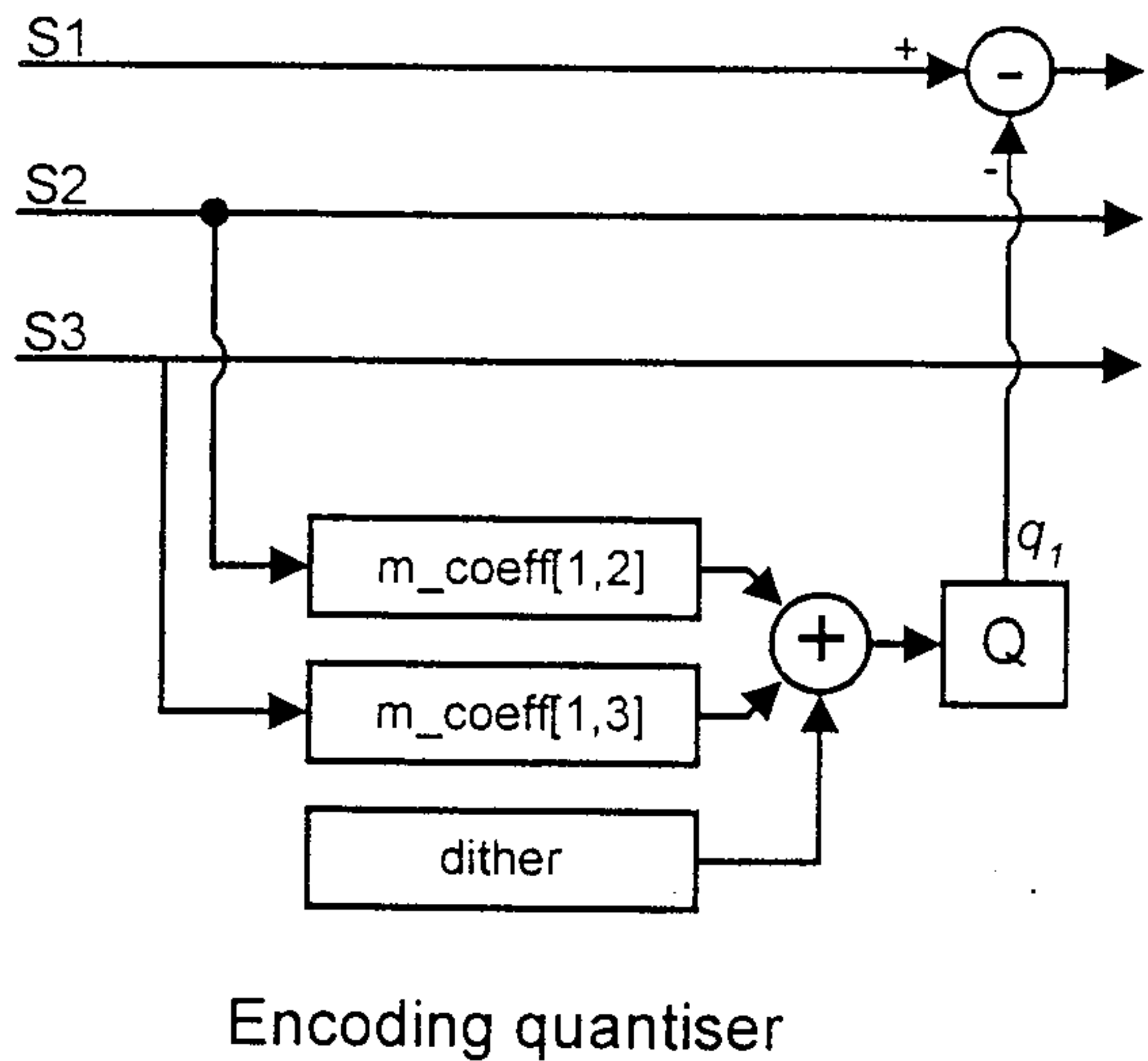

Figure 5a

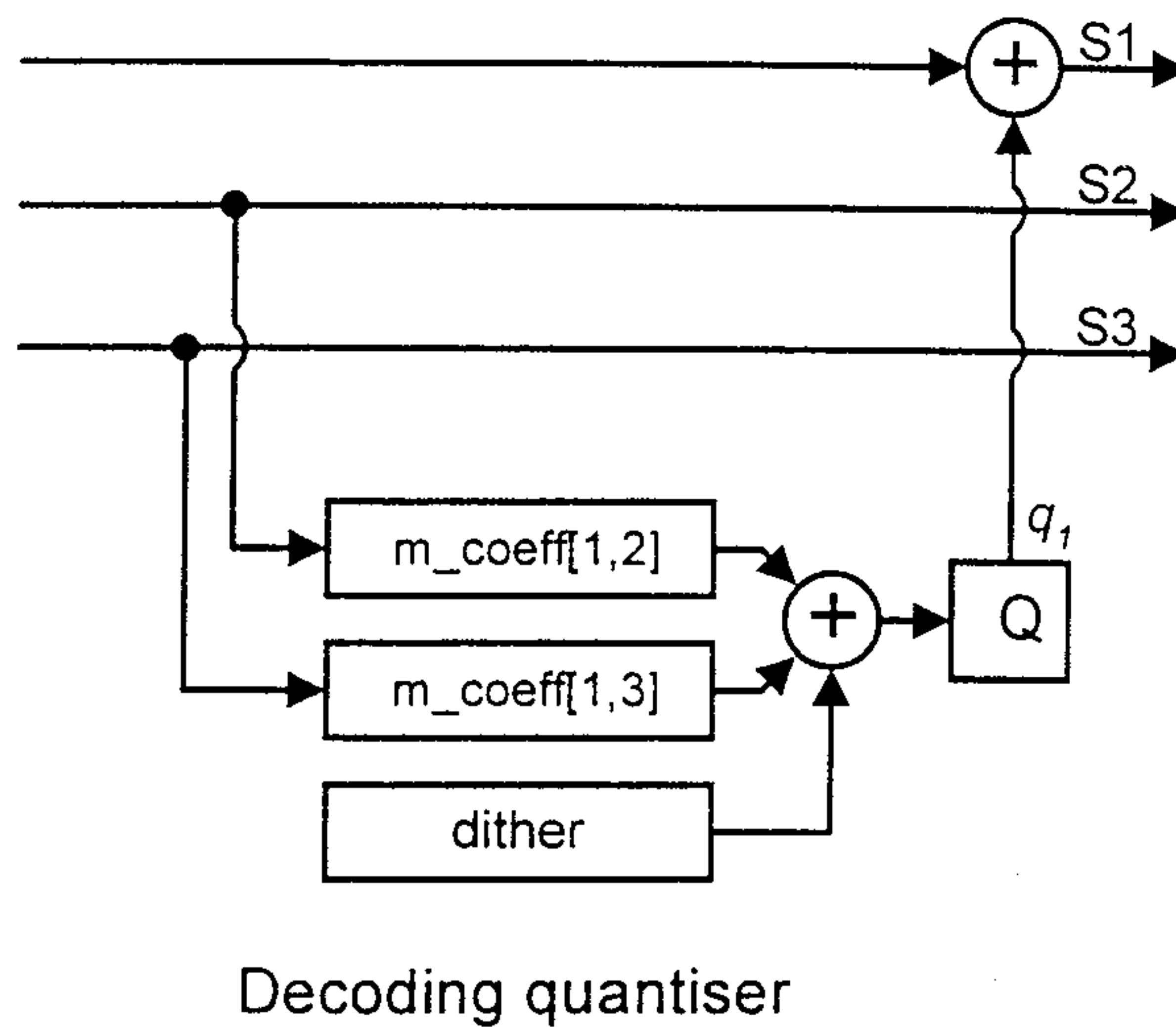

Figure 5b

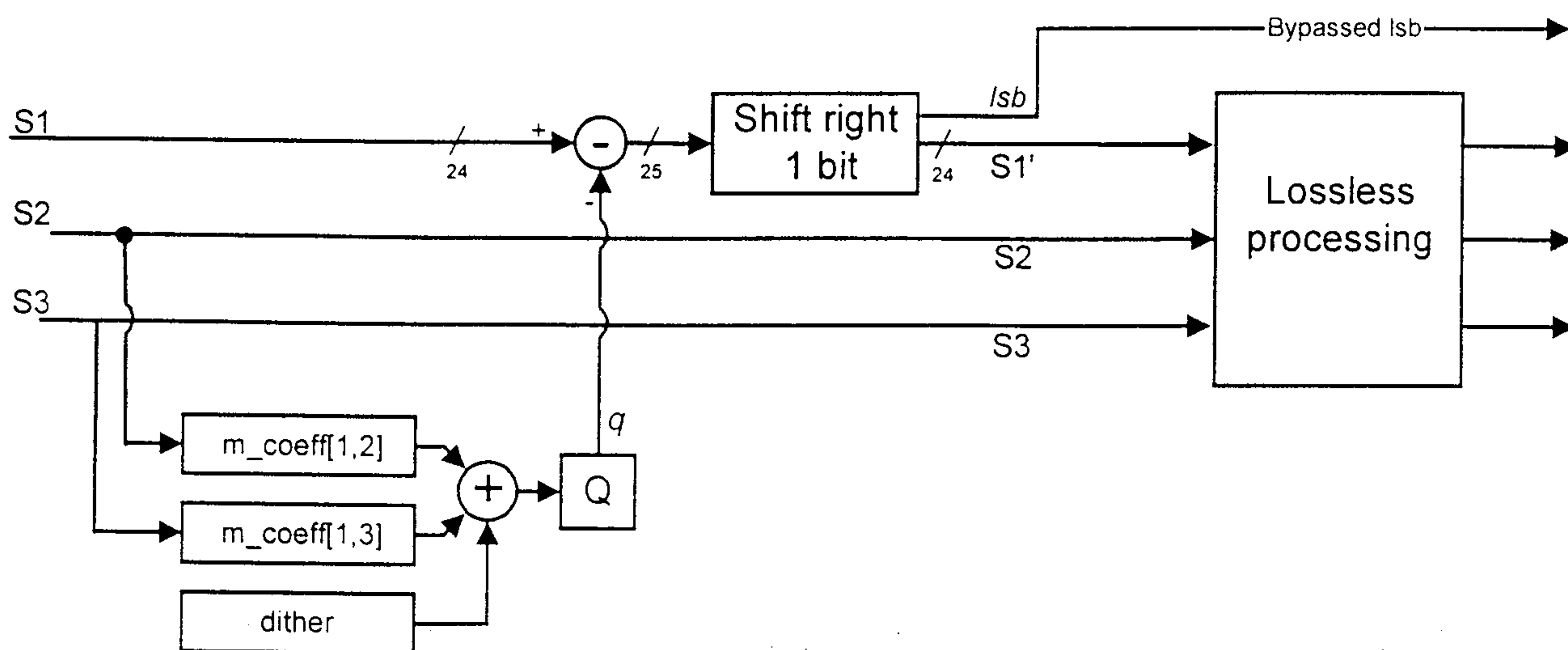

Figure 6a

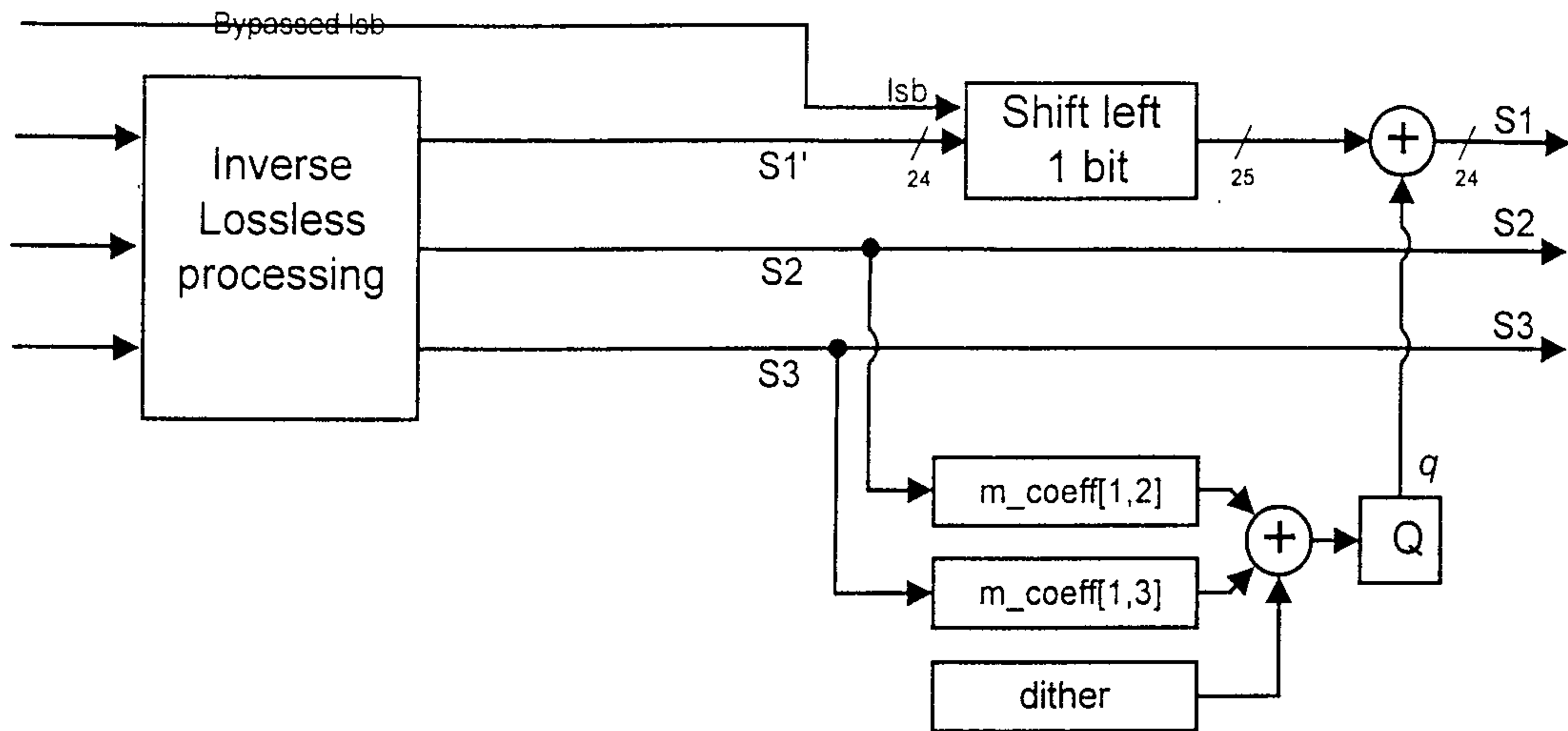

Figure 6b

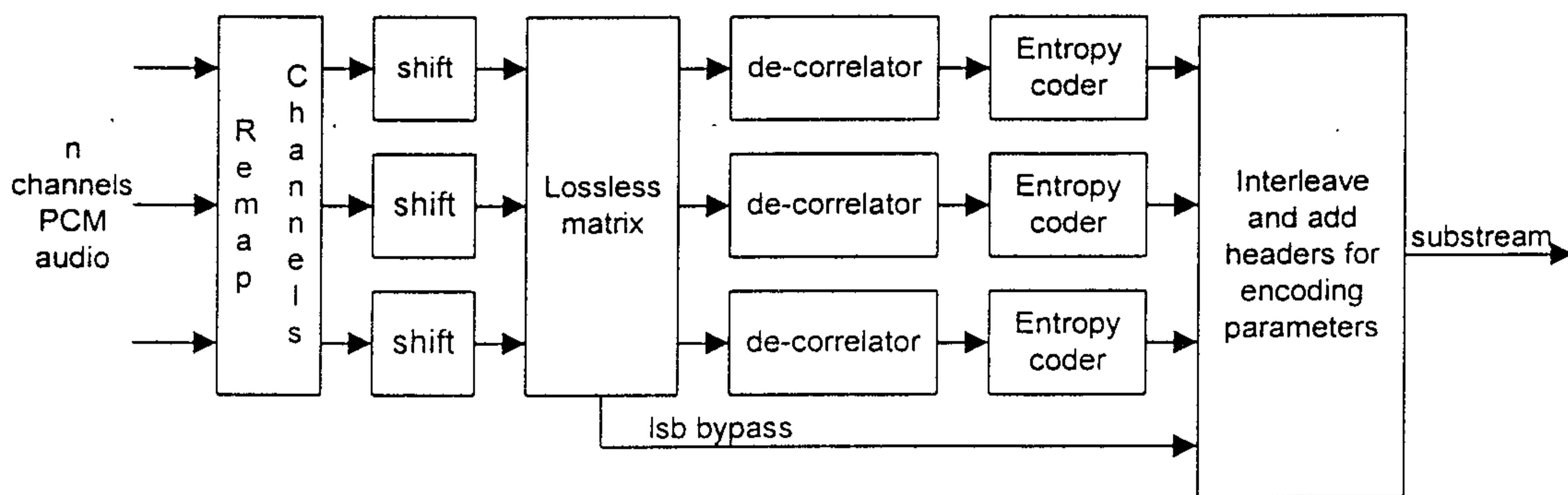

Figure 7a

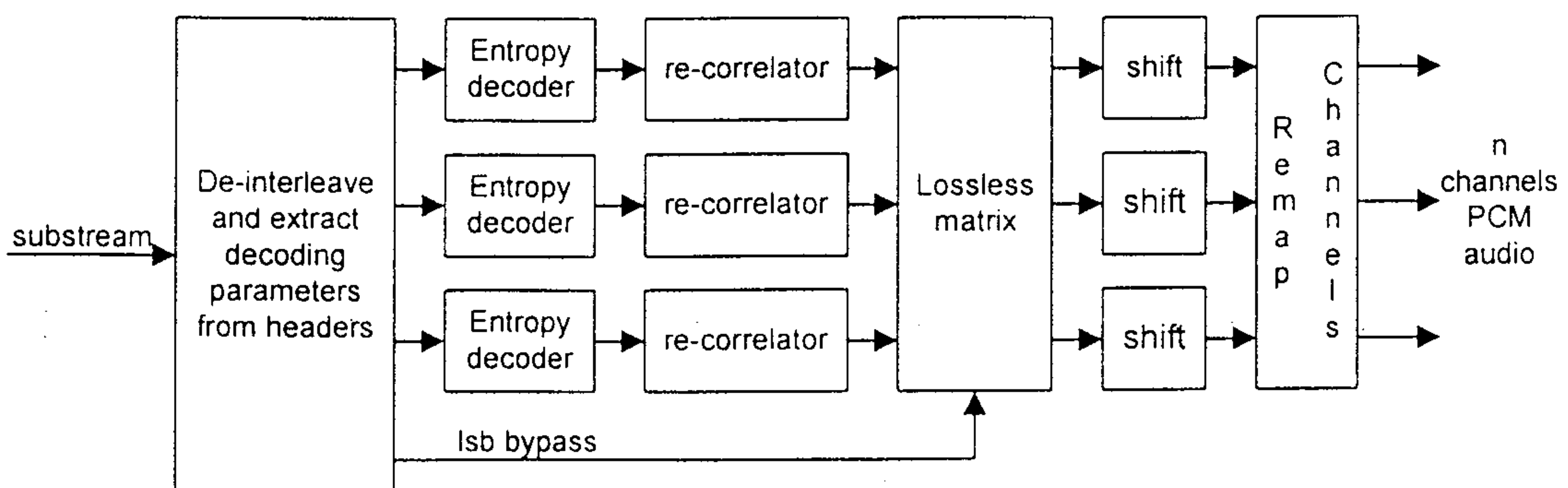

Figure 7b

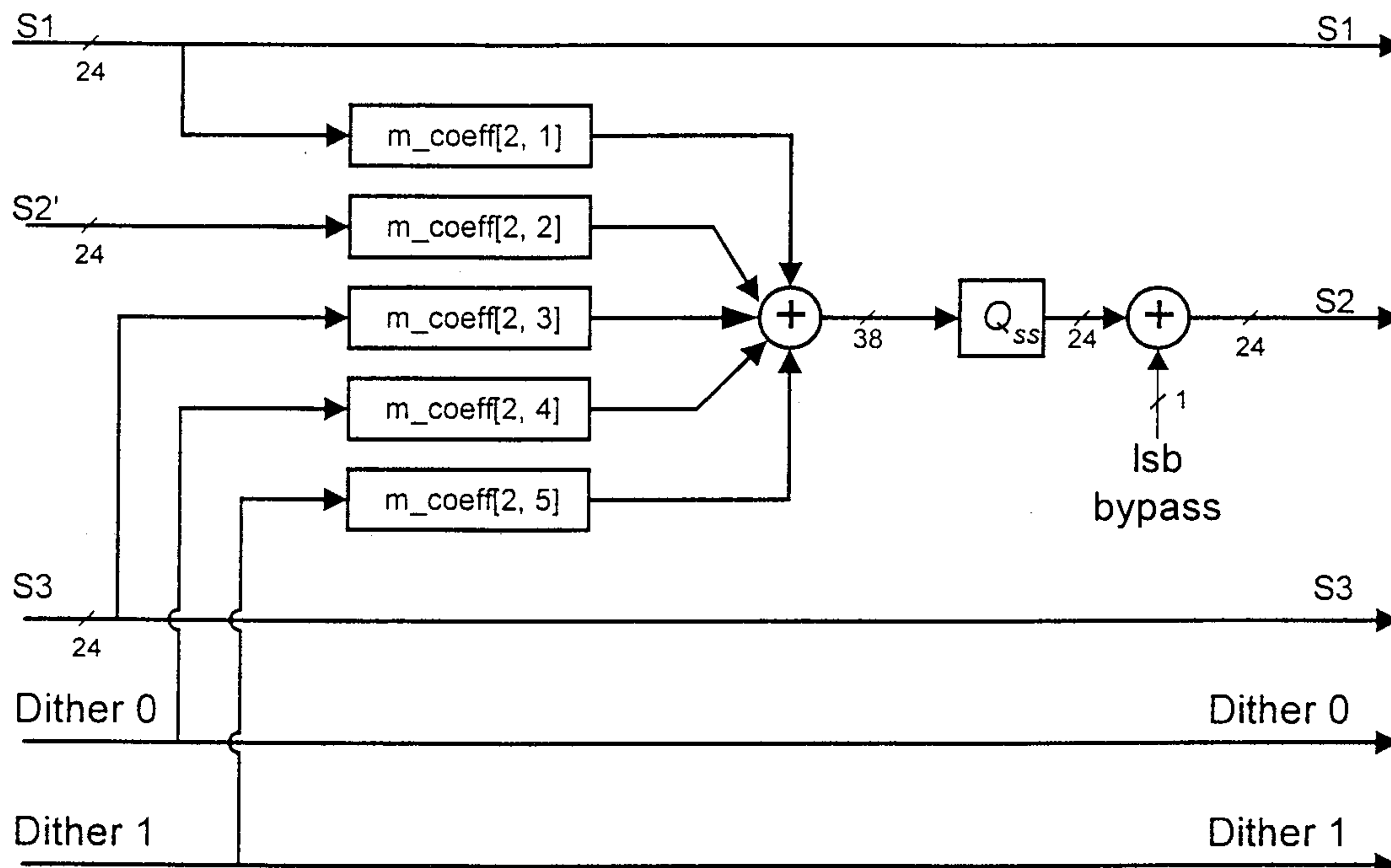

Figure 8

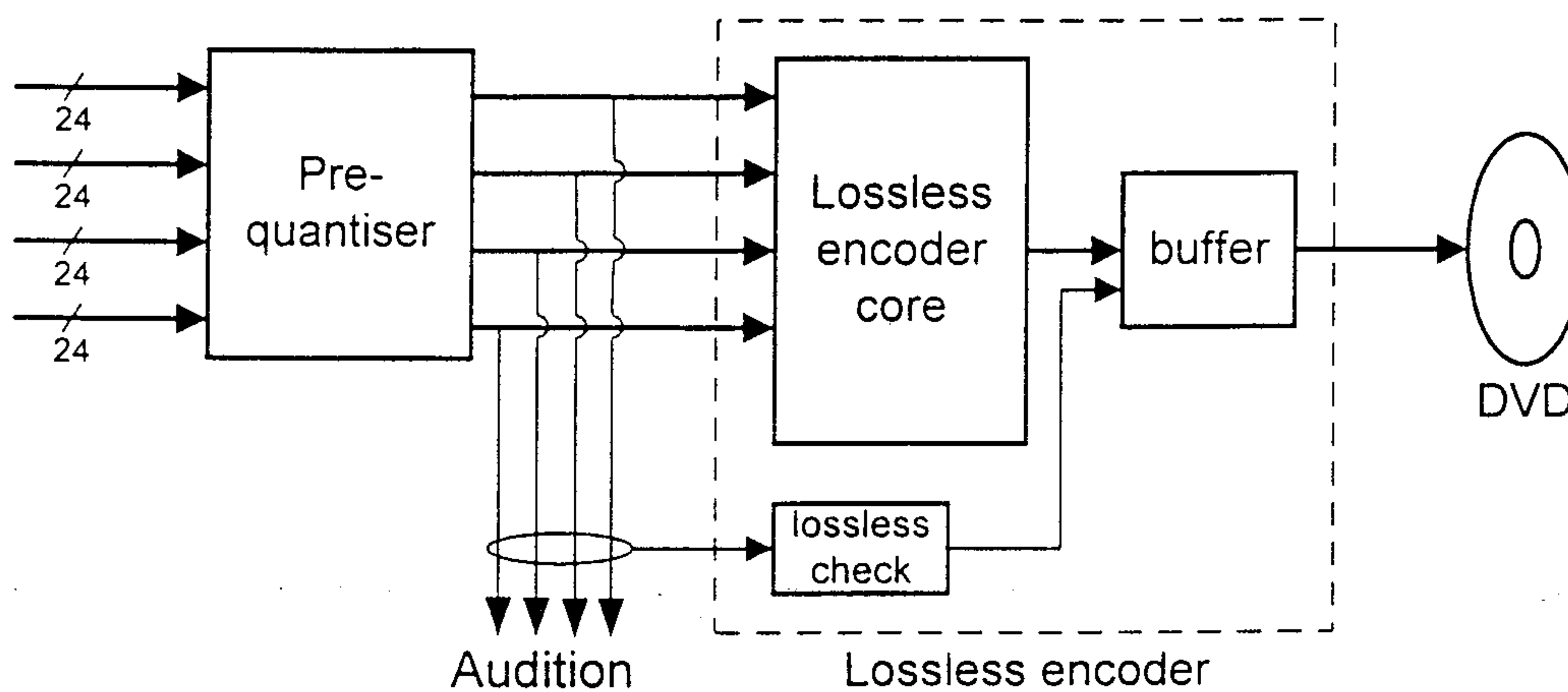

Figure 9

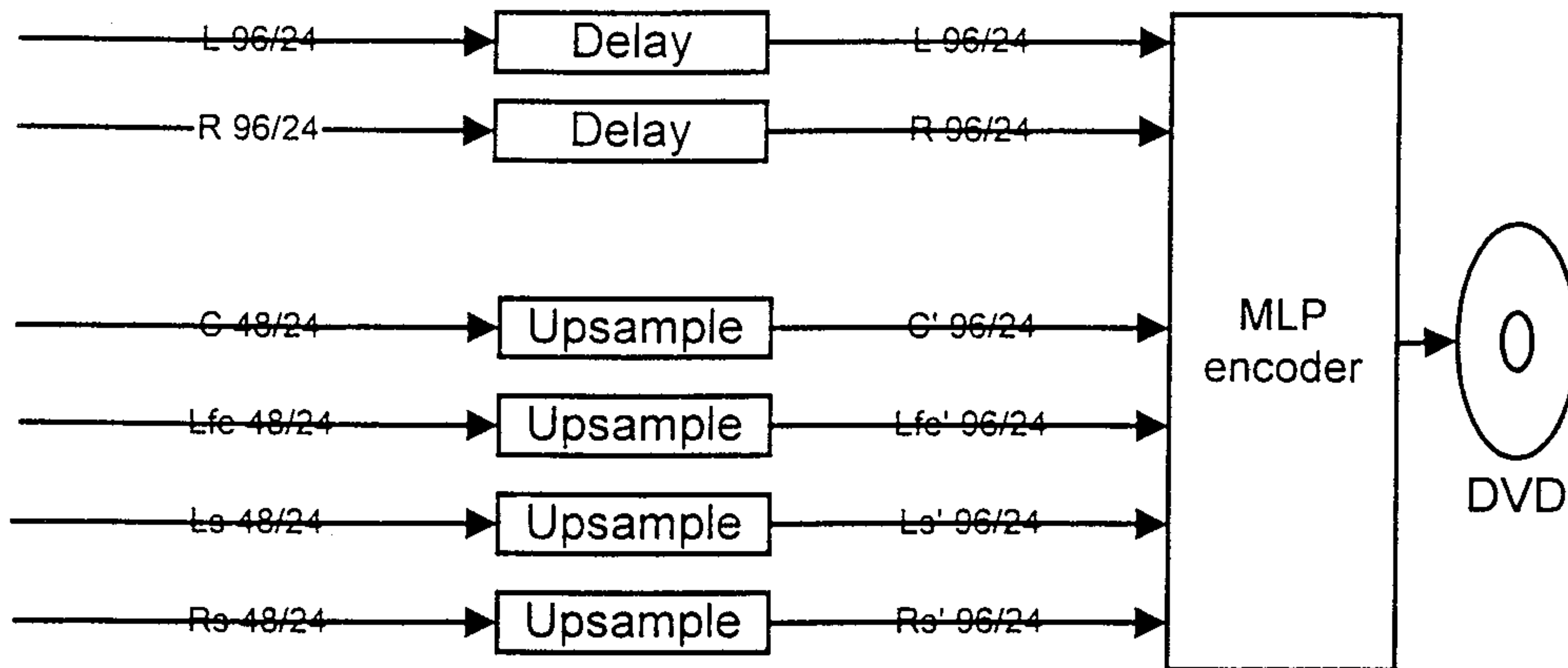

Figure 10.

