

May 9, 1933.

V. OLDBERG

1,907,656

ASSEMBLY MACHINE AND METHOD

Filed June 27, 1932

2 Sheets-Sheet 1

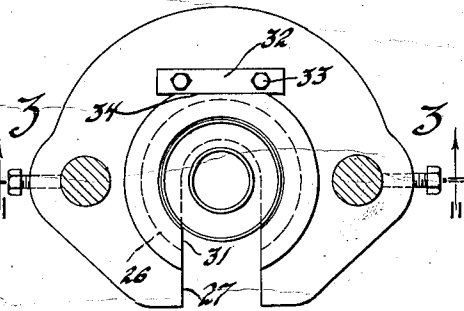
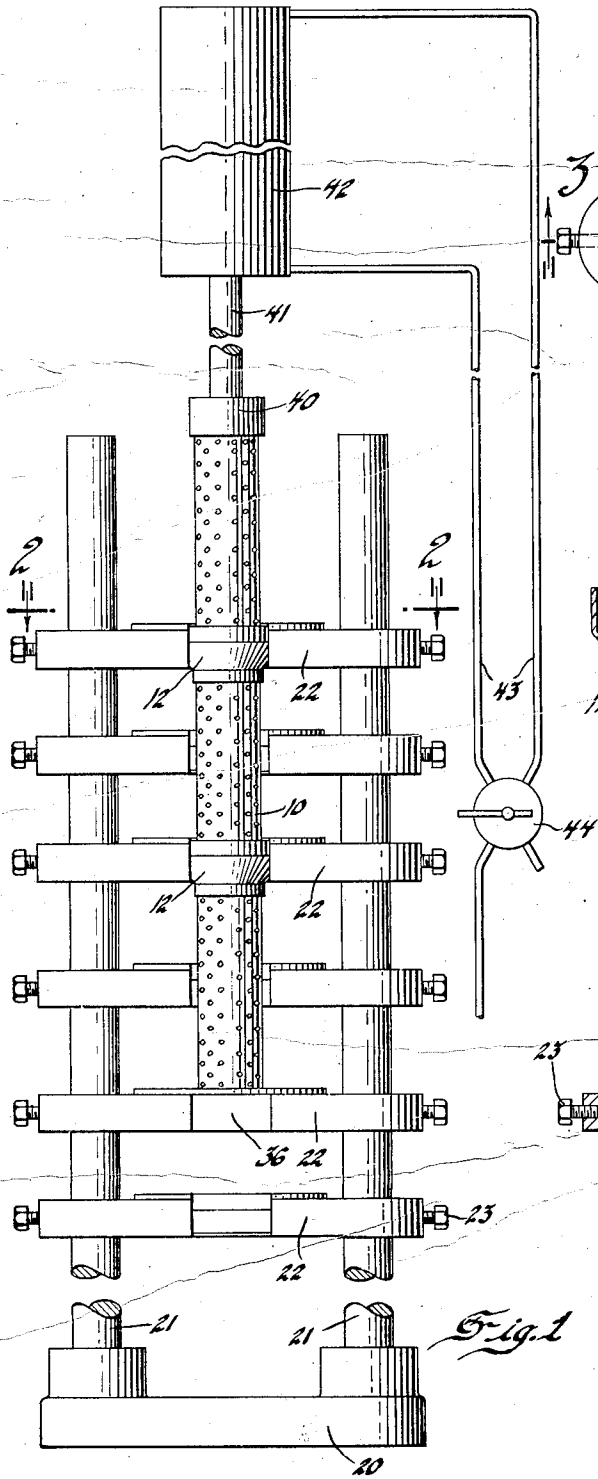

*Fig. 2*

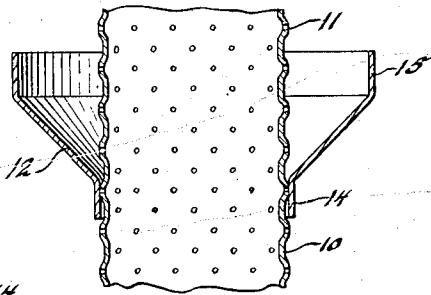

*Fig. 4*

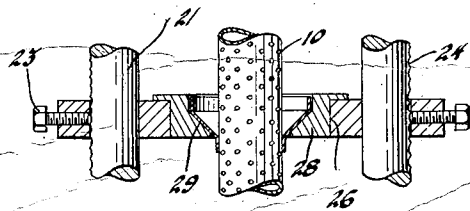

*Fig. 3*

*Fig. 1*

INVENTOR.  
*Virgil Oldberg*  
BY  
*Robert A. Ruland*  
ATTORNEYS.

May 9, 1933.

V. OLDBERG

1,907,656

ASSEMBLY MACHINE AND METHOD

Filed June 27, 1932

2 Sheets-Sheet 2

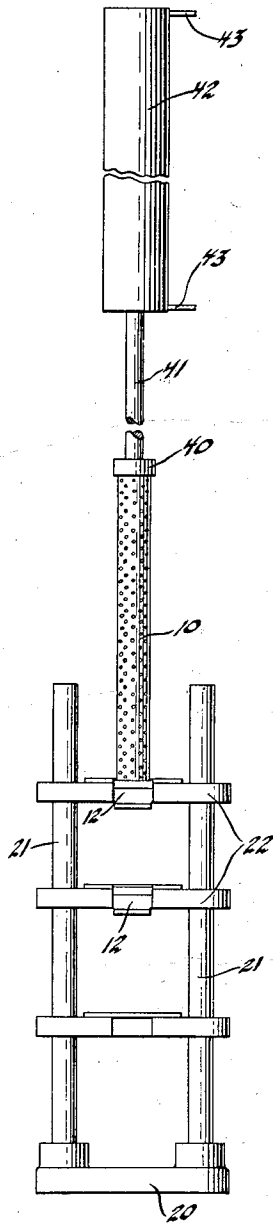

*Fig. 5*

*Fig. 6*

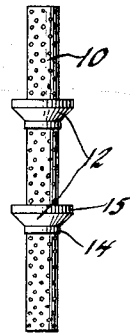

*Fig. 7*

INVENTOR  
*Virgil Oldberg*  
BY  
*Carlhoff & Carlhoff*  
ATTORNEY

# UNITED STATES PATENT OFFICE

VIRGIL OLDBERG, OF DETROIT, MICHIGAN, ASSIGNOR TO OLDBERG MANUFACTURING COMPANY, OF DETROIT, MICHIGAN, A CORPORATION OF MICHIGAN

## ASSEMBLY MACHINE AND METHOD

Application filed June 27, 1932. Serial No. 619,504.

The invention of this application relates to a machine and method for assembling parts. The invention is disclosed in connection with an elongated muffler shell upon which are to be assembled, in spaced relation, a plurality of annular diaphragms.

In my copending application, Serial No. 613,440, filed May 25, 1932 (#4016), I disclose an elongated, sheet metal, shell having a plurality of closely spaced outwardly extruded, minute perforations covering the entire area of the shell, the shell being provided with a plurality of axially spaced diaphragms in the nature of annular members, each of the diaphragms being more accurately a frusto-conical, sheet metal part, having cylindrical flanges projecting axially from both the large and small ends of the frustum of the cone. The present invention has, for its principal objects, a novel machine and a novel method for assembling a plurality of these annuli in predetermined spaced relation upon the shell.

Still another object of the invention is to provide novel parts for use in assembling annuli upon an elongated member.

Still further objects of the invention will appear upon reference to the following detailed description of the same and upon reference to the appended drawings, in which—

Figure 1 shows an assembly machine of the invention, with a muffler shown therein, in assembled state;

Fig. 2 is a section as if on the line 2—2 of Figure 1;

Fig. 3 is a section as if on the line 3—3 of Figure 2;

Fig. 4 is an enlarged fragmentary view of a muffler shell and an associated annulus;

Fig. 5 shows a machine of the invention with parts about to be assembled shown in place;

Fig. 6 shows a muffler shell per se for use with a machine and method of the invention;

Fig. 7 shows an assembly of a muffler shell and spaced annuli, forming a product of the machine and method of the invention.

### *The work*

Referring to the drawings, it will be observed that the elongated member or muffler shell upon which the annuli are to be assembled in predetermined spaced relation comprises an elongated tube 10 of sheet metal provided with a large number of closely spaced, minute, outwardly extruded perforations 11 covering substantially the entire area of the shell. The assembly includes the muffler shell 10 and a plurality of annuli 12 which are in the nature of frusto-conical, sheet metal members, having cylindrical flanges 14 and 15 projecting axially and away from the frusto-conical portions of the members, substantially as indicated. A plurality of the members 12 are provided, as many as desired, and while in the drawings the assembly is shown as being provided with but two of these, it will of course be understood that many more may well be provided and the present invention contemplates the assembly of as large a number of these members as desired. Further these members are securely fixed to the shell by the method of the invention and are secured thereon in predetermined spaced relation.

### *The machine*

The machine of the invention, which assembles the members 12 or cones, as they are often described, upon the shell includes a base 20 from which project upwardly a plurality of posts 21, two only of these being shown, although others may be provided if desired. The upper ends of the posts are free, as shown. Slidable upon the posts and placed thereon over the free ends of the latter are a plurality of supporting plates 22 which are relatively heavy so as to be rigid and so

as to be capable of withstanding great pressures without deflection. The plates are provided with set screws 23 whose ends are adapted to be engaged in any one of a number of closely spaced, aligned notches 24 in the posts. The plates 22 may be spaced in predetermined relation, in accordance with the predetermined spacing for the cones, and when so spaced may be clamped in place on the posts 21 by the set screws 23. Each of the plates has a relatively large central aperture 26 and a relatively wide slot 27 connecting the aperture 26 with the edge of the plate, to provide an exit way for the assembled muffler shell, as will later be described.

Adapted to be placed in the central apertures 26 are filler pieces 28 having central, frusto-conical apertures or seats 29 in which may be seated the frusto-conical members 12. It will be observed at this time that for any machine there are provided a large number of these filler pieces having differently sized and shaped central apertures, corresponding to the various sizes and shapes of the cones which are to be assembled in the machine, the filler pieces being selected for the particular size and shape of the cones. Further, each filler piece 28 has a slot 31 of the same size as the slots 27 of the plates, these slots cooperating when aligned, to define an exit way for the assembled muffler shell. Further each plate has, on the side thereof opposite its slot 27, an orienting bar 32 held securely thereon by bolts 33, which bar has a flat surface adapted to cooperate with a flat surface 34 of the filler pieces, to orient the latter with respect to the plate so that the slots 31 and 27 will be in accurate alignment.

Another set of filler pieces 36, are provided, and each of these, instead of having a central aperture and seat 29 and a slot 31, is in the nature of blank filler pieces, that is to say, it is a solid filler adapted to plug the aperture of the plates 22, for purposes to be described.

The parts so far mentioned comprise the stationary members of the machine and are set up for a particular job and thereafter not moved.

The movable part of the machine is in the nature of a ram 40 mounted on the end of a piston rod 41 reciprocable in a cylinder 42, the ram being movable along the axis of the aligned filler piece apertures 29 substantially as indicated. For moving the ram along such axis back and forth, any power means may be used and a conventional compressed air or fluid pressure, power means is indicated by the pipes 43 to be controlled by a valve 44. It will be understood at this time that means other than the pneumatic or fluid pressure power means might be used with attendant results.

#### *The method*

The method of the invention will now be

described with reference to the machine disclosed. When the machine is set up for a particular assembly one of the plates 22 will be provided with a blank filler piece 36. Others of the plates will be provided with filler pieces 28 selected for the particular assembly desired, all of the plates being spaced along the posts 21 in accordance with the desired spacing of the cones on the muffler shell; so set up the machine is ready for use.

The first step is to have the ram 40 in its most elevated position, substantially as shown in Figure 5. After the ram is elevated or while it is being elevated, cones are placed and seated in the filler pieces 28, these cones readily finding their proper positions in these filler pieces due to the fact that the apertures or seats 29 are designed to fit the cones being used. The plates 22 at this time support and space the cones in accordance with the desired spacing.

The operator then, while the ram is elevated, places a muffler shell in the machine with its end adjacent the uppermost one of the filler pieces 28 and with its axis in line with the axis of the filler pieces. It will be observed that it is not necessary for the operator to hold the muffler shell in place, for its own weight, coupled with the fact that it finds its seat in the uppermost one of the cones already placed in the machine, serves to hold the shell in place without assistance.

The operator then manipulates the valve 44 to cause the ram 40 to be lowered. The ram engages the upper end of the muffler shell and slowly forces the muffler downwardly through the various filler pieces until the lower end of the muffler shell engages and is stopped by the blank filler piece 36. At this time the operator manipulates the valve 44 to stop advance movement of ram 40 and to return the ram to its elevated position. All that remains then for the operator is to remove the assembly of the muffler shell and the cones, which he does by raising the assembly slightly in the machine, so that the cones are clear of the filler pieces and then sliding the assembly transversely out of the machine, with the muffler shell passing through the aligned slots 31 and 27.

Broadly the method may be described as including the steps of forcing a muffler shell or other elongated member through a plurality of suitably spaced and supported annuli along the longitudinal axis of the elongated member and along the longitudinal axis of the aligned annuli, and removing the assembly from the assembly device or machine transversely of such axes.

It will be observed at this time that the extrusions of the perforations 11 on the muffler shell cooperate with the flanges 14 in a manner which assists in creating a satisfactory securement between the muffler shell and the cones. The flanges 14, being of sheet metal

and being attached to the frusto-conical parts of the members 12, are more or less pliable and as the muffler shell is forced through the cones the flanges 14 give slightly to permit passage of the muffler shell and then contract to effect what amounts to a press fit at the flanges 14. This feature is of particular importance in connection with sheet metal work, where manufacturing inaccuracies and tolerances might otherwise prevent the use of the method disclosed.

It will further be observed that while the cones are securely fastened to the muffler shell by the method of the invention, such securement may be enhanced and preferably is enhanced for muffler use, by welding the cones to the shell after the cones are assembled with respect to the same. The assembly of the invention makes the task of welding the cones to the shell much easier since the assembly may be brought to and manipulated in the welding machine without fear of relative movement between the cones and the shell.

Now having described the invention and embodiments thereof, it will be observed that the same is not to be limited to the specific details shown, but only by the scope of the claim which follows.

What I claim is:—

The method of assembling spaced sheet metal plates having axially alined holes on an elongated hollow sheet metal cylindrical member, which comprises forming resilient axially extending edge flanges continuously around the axially alined holes, forming resilient outward projections on the member, and pressing the member, through the holes of the plates, with the flanges engaging the projections so that their mutual resiliency will cooperate in maintaining the plates and the member in assembly.

In testimony whereof I affix my signature.  
VIRGIL OLDBERG.