

EUROPEAN PATENT APPLICATION

Application number: 90830056.9

Int. Cl.⁵: B66B 9/00

Date of filing: 14.02.90

Priority: 14.02.89 IT 334289

Applicant: **Toschi, Luigi**
Via Vallescura, 2
I-40136 Bologna(IT)

Date of publication of application:
22.08.90 Bulletin 90/34

Inventor: **Toschi, Luigi**
Via Vallescura, 2
I-40136 Bologna(IT)

Designated Contracting States:
AT BE DE FR GB NL

Representative: **Lanzoni, Luciano**
c/o BUGNION S.p.A. Via Farini, 37
I-40124 Bologna(IT)

54 Roto-elevator for multi-storey garages.

57 The roto-elevator consists of an underground tower structure (4) wherein there is another tower (4a) which rotates about its own axis and within which there is an elevator (5) centrally installed and running vertically to and from the surface and the different levels of parking stalls (2) arranged radially on each floor of a cylindrical static structure (1). Drive means (6) are envisaged to rotate the tower about its axis (y) in such a way as to enable the axial alignment of the elevator (5) with any one of the vehicle parking stalls. Cantilever platforms are also envisaged, at each floor of the static structure, which complement the core (1a) of the tower (4) and which rotate with the tower (4a) in such a manner as to join horizontally and uninterruptedly the said tower (4a) to each floor of parking stalls.

EP 0 383 734 A2

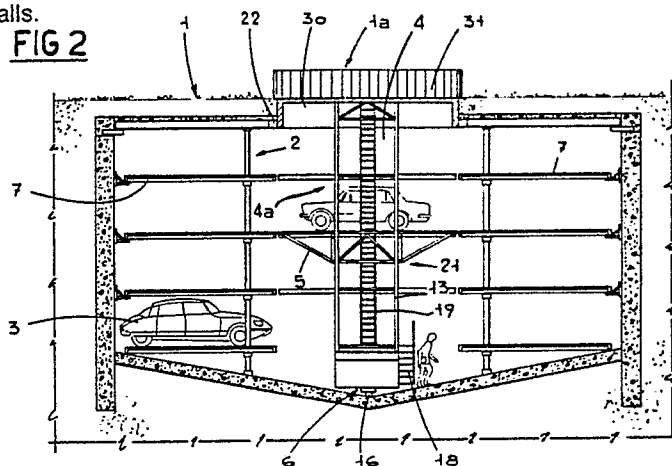

Roto-elevator for multi-storey garages

The present invention concerns a roto-elevator for multi-storey garages consisting of a static structure with two or more floors, basically cylindrical or ovoid, and comprising a plurality of parking stalls arranged radially on every floor, each stall being designed to accommodate one vehicle.

When designing automatic underground car silos of relatively small size (for the limited requirements of condominiums, office blocks, etc.), it is convenient to adopt a circular structure, with the cars distributed radially by means of a roto-elevator, rather than a parallelepipedal structure in which the cars are parked side by side in opposing shelf units by means of a transelevator. In a circular car silo, the surface area of the walls that bear the load of the surrounding soil is much less than that of the walls of a rectangular car silo. This is important if one considers that the total cost of the structure is to a large extent made up of the cost of the load-bearing walls.

At present, cylindrical underground silos envisage the presence of a roto-elevator, installed in what may be regarded as the core of the structure, and consisting of a vertical, latticed tower frame rotating about the axis of the core, and of an elevator which runs vertically within the latticed tower and which is designed to carry the motor vehicles to be parked. The vehicles are loaded onto, and withdrawn from, the elevator platform by mechanical arms or pushing devices.

To prevent the latticed tower from deforming in relation to the static structure as a result of the heavy loads, its verticality is ensured by two beams, one located at the base and the other at the top of the tower itself. The beam at the top must be located above the vehicles arriving from the surface and for this reason a large structure is necessary above ground.

In garages of the kind just described, the static structure enclosing the underground cylinder must also contain an inspection gangway running the entire perimeter of the structure itself on the outside of the space occupied by the parking stalls, and must be equipped with at least one ladder joining the gangway to the surface and with two or more ventilation ducts. Consequently, the internal diameter of a traditional underground cylindrical car silo must envisage two opposite vehicle parking stations, a central shaft or core to house the roto-elevator and two opposite gangways running along the outside, whilst the outgoing vehicles station and the top rotary beam require a considerably large structure above ground. In addition, the surface is crossed by the ventilation ducts and the room that gives access to the inspection ladder.

For these reasons, the surface is almost entirely occupied by unattractive constructions above ground level.

The object of the present invention is to propose a rotary tower to serve as a garage, cylindrical or ovoid in shape, constructed in such a way as not to require outside inspection gangways and auxiliary ventilation ducts, the tower itself being equipped with a network of internal passageways enabling quick and easy movement to and from all key points in the garage, and the tower itself acting as a ventilation flue, the entire construction being safe and unobtrusive, the only structure visible above ground being a simple circular guard rail to protect the roto-elevator.

The invention, as characterized by the claims herein, solves the aforementioned inconvenience by means of a single underground tower that rotates about its shaft in the central core. Within the said tower there is an elevator installed in the central portion of the tower itself and running vertically to and from ground level and the floors corresponding to the various different levels of parking stalls, the latter being arranged radially on each floor of a cylindrical static structure built around the said tower. Drive means are envisaged to rotate the tower about its axis in such a way as to enable the elevator to line up horizontally with any parking stall. The invention also envisages cantilevers, at each floor of the static structure, which complement the aforesaid core and which rotate with the aforesaid single tower in such a manner as to join horizontally and uninterruptedly the aforesaid tower to each floor in the static structure or to the surface.

One of the advantages achieved with the present invention lies basically in the fact that it is possible to create service passageways integrated with the roto-elevator itself, with the following advantages:

- reduced inside diameter of the containing cylinder, which means a considerable saving in costs and space;
- unattractive structure above ground level is unnecessary;
- ventilation ducts are unnecessary.

The advantages of the present disclosure are highlighted in the following detailed description of its preferred, although not sole, embodiment, with reference to the accompanying drawings, where:

- Figure 1 shows a side cutaway view of a roto-elevator described in the present specifications.

- Figure 2 shows a cutaway side view of a roto-elevator as in Fig.1, during the parking of a

vehicle.

- Figure 3 is a plan view of the ground surface level of a garage equipped with the roto-elevator illustrated in Fig.1.

- Figure 4 shows a cutaway plan view of one of the floors of a garage equipped with the roto-elevator illustrated in Fig.1.

- Figure 5 is a diagrammatic view in perspective of a roto-elevator for a garage with two storeys only, constituting an alternative to the garage shown in the other illustrations.

With reference to the illustrations just mentioned, the roto-elevator described herein is designed for garages of the type consisting of a multi-storey static structure 1, basically cylindrical or ovoid in shape, wherein there is a plurality of parallelepipedal stalls 2, arranged radially on every garage floor, each stall to accommodate one vehicle 3 (in the garage illustrated, the said stalls consist of simple floors that are open on the side. The static structure 1 is built around a cylindrical core 1a designed to house the structure 4 for the vertical and radial handling of vehicles 3.

Structure 4, which is basically the roto-elevator described in these patent specifications, is made up of an underground tower 4a which rotates about its axis y which coincides with the axis of the core 1a. The inside of tower 4a is equipped with an elevator 5 installed in the central portion of the tower itself and moving vertically to and from ground level and the floors corresponding to the various different rows of parking stalls 2.

The invention envisages drive means 6 to rotate the tower 4a about its axis in such a way as to enable the elevator 5 to line up horizontally with each floor 7 of parking stalls 2 (see Fig.4) and winch type traction means 32 (see Fig.3) to lift and lower the elevator itself. The invention also envisages cantilevers 8 and 9, at each floor of the static structure 1, which complement the aforesaid core 1a and which rotate with the aforesaid single tower 4a. The said cantilevers are shaped in such a manner as to join the aforesaid tower 4a to each floor 7 in the static structure 1.

The said cantilevers 8 and 9 (see Fig. 3) consist of two gridded platforms substantially semi-circular in shape. Platforms 8 and 9 are co-planar and sited on opposite sides of the centre of the aforesaid tower 4a. Obviously, these platforms are located at each floor in the aforesaid static structure 1 and are designed in such a way that the central portions allow free access to all parts of the aforesaid elevator 5. For this purpose, the two platforms 8 and 9 have openings 8a and 9a in the middle to allow a person to gain access to the floor by means of the ladder.

The aforesaid drive means 6 consist of a shaft 16, driven by motor 16a that rotates about its own

axis and that is associated, at its ends, coaxially to the aforesaid tower 4a (and more precisely, to base 14) and respectively to the bottom of static structure 1. The said motor 16a, together with the aforesaid winch 32 (or equivalent means such as a central or lateral hydraulic piston) is controlled by the centralized control system 17 (see Fig.3) which is not fully illustrated because it is of known type (for example, electronic card rack, control board, etc).

Figures 1 and 2 show a garage tower 4 with four floors of stalls 2 but the invention might apply equally well to a different number of floors. In Figs. 1 and 2, structure 4a consists of two parallel, opposite latticed towers 13 built under ground and equipped with corresponding, opposite internal guides 21 within which the aforesaid elevator 5 runs. The towers 13 are associated at one end 13a, to a base 14 at the bottom of structure 1 and equipped coaxially with motor-driven shaft 16 or with a thrust bearing. The latticed structure of the aforesaid towers 13 serves also to provide horizontal support for the aforesaid gridded platforms 8 and 9 in such a way that the latter are co-planar with the various different floors 7.

As illustrated, again in Figs.1 and 2, the base 14 presents an angled profile that complements the profile of the bottom of structure 1 and that is built in such a way as to resist the backthrust of the soil, collect groundwater, accommodate the platform of elevator 5 and provide working room for inspection and maintenance personnel.

To erect tower 4, base 14 must first be laid on the bottom of the structure and towers 13, to house the elevator 5, then fixed to the said base. Finally, the tops of the two towers must be joined in order to make the entire structure solid by means of arched means 30 which form a ring joining the components of the roto-elevator. The said rotating ring is in contact with rollers 22 fixed to the static structure and designed to keep the roto-elevator vertical and prevent deformation even under heavy, eccentric loads.

In all the illustrations, 18 and 19 indicate ladders running parallel to tower 4a from the top to the bottom of the same. The said ladders 18 and 19 are sited diametrically opposite each other in such a way that each connects the said gridded platforms 8 and 9 to the corresponding platforms on the floors above and below, thanks to the aforesaid openings 8a and 9a made in the platforms themselves. In practice, opening 9a for ladder 19 connects the surface directly to the bottom of the garage and may also be used for the passage of materials., whilst opening 8a (wider than 9a) for ladder 18 is designed to give easy access to inspection personnel.

Normally, all the drive motors are mounted at

the top of the tower 4. The vehicle 3 loading and withdrawal devices, indicated with 33, are of known kind and are not illustrated in detail. The said devices complete the elevator 5 to which they are fixed. The fixed circular guard rail is indicated with 31.

With reference to Fig.5, which shows a simplified alternative particularly suitable for a car silo with two floors only, tower 4a consists of two vertical parallel bars 10 located opposite each other. The said bars 10 are fitted with opposite internal guides 20 within which the elevator 5 runs.

At their bottom ends 10a, bars 10 are attached to a quadrangular base 11, which is equipped, coaxially and on the side opposite to that where the bars 10 are attached, with the aforesaid drive means 6. Bars 10 are also equipped with lateral supporting means 12 designed to secure them to the aforesaid cantilevers 8 and 9 so that the latter are co-planar with floor 7.

More precisely, the supporting means 12 consist of a pair of stays for each bar on each floor. One end of each of these stays 12 is attached to a bar 10 and the other end to one of the cantilevers 8 and 9. As shown in Fig.5, bars 10 may be attached to base 11 with another pair of stays 25 in order to further stabilize the entire tower 4a.

According to the present invention, the roto-elevator operates as described below.

When vehicle 3 has been safely positioned on elevator 5, the operator at control unit 17 lowers the elevator itself to the floor where the desired stall 2 is located and at the same time control unit 17 activates motor 16a which rotates tower 4 until elevator 5 lines up axially with platform 2. After lining up, elevator 5 unloads the vehicle onto stall 2 and returns to the surface.

One of the main advantages offered by the present structure compared to existing garages of a similar kind is that the gridded cantilever platforms 8 and 9 and ladders 18 and 19 allow easy access to all the parking stalls at all the floors in structure 1. This means that personnel may safely reach all parts of the structure 1 in order to carry out repairs, for example. As shown in Fig.2, tower 4 has no cantilever platforms at the lowermost parking floor so as to facilitate movement of personnel at the said floor.

Another fundamental advantage lies in the fact that the gridded platforms allow the entire central core portion of the tower to act as a ventilation flue, sufficiently large in relation to the size of the tower, without necessitating additional vents which would mean increasing the total surface area of the car silo. Moreover, the said platforms close off the core portion to a sufficient extent to confer complete safety on the entire car silo structure.

Another advantage is achieved thanks to the

architectural form of the roto-elevator and to its method of open construction which does away with the need for access ramps and high unsightly structures above ground (this is true only of the silo shown in Fig.5).

Although the invention has been described in connection with specific embodiments thereof, changes and modifications may be made therein without departing from the scope of the appended claims. In addition, all the details may be replaced by technically equivalent parts.

Claims

1) A roto-elevator for multi-storey garages of the type consisting of a static structure (1) with two or more floors, basically cylindrical or ovoid in shape, and comprising a plurality of parking stalls (2) arranged radially on every floor, each stall being designed to accommodate a vehicle (3), the said static structure (1) being built around a cylindrical core (1a) that is made up of a tower (4a) for the vertical and radial handling of the vehicles (3) which rotates about its own axis and which is equipped with an elevator (5), installed in the central portion of the tower itself and moving vertically to and from ground level and the floors corresponding to the various different rows of parking stalls (2); drive means (6) being provided to rotate the tower 4a about its axis in such a way as to enable the axial alignment of elevator (5) with each parking stall (2), and means (32) to lift and lower the elevator (5) itself, **wherein** the aforesaid tower (4) is equipped with cantilevers (8 and 9), at each floor of the said static structure (1), which complement the aforesaid core (1a) and which rotate with the aforesaid tower (4a) in such a manner that, when the elevator platform is at a floor, the aforesaid tower (4a) is joined horizontally and uninterruptedly to each floor (7) in the static structure (1) or to the surface.

2) Roto-elevator as in claim 1 **wherein** the aforesaid tower (4a) consists of two parallel, opposite towers (13) built under ground and equipped with corresponding, opposite internal guides (21) within which the aforesaid elevator (5) runs, the said towers (13) being associated at their lower end (13a, to a base (14) equipped coaxially with a shaft or thrust bearing (16) forming part of the aforesaid drive means (6), and the said towers (13) also having a latticed structure serving to provide horizontal support for the aforesaid cantilever platforms (8 and 9) in such a way that the latter are co-planar with the various different floors (7).

3) Roto-elevator as in claim 1, **wherein** the aforesaid cantilever platforms (8 and 9) are substantially semi-circular in shape and attached to the

aforesaid tower (4a); the said platforms (8 and 9) being co-planar, on opposite sides of the centre of the said tower (4a), at each floor in the said static structure (1), and designed in such a way that their central portions allow free access to all parts of the aforesaid elevator (5), the said platforms (8 and 9) having openings (8a and 9a) in the middle to allow a person to gain access to the floor.

4) Roto-elevator as in claim 1, **wherein** the aforesaid tower (4a) has associated to it a pair of ladders (18 and 19) running parallel to the tower (4a) from the top to the bottom of the same, the said ladders (18 and 19) being sited diametrically opposite each other in such a way that each connects one of the aforesaid grilled platforms (8 and 9) to the corresponding platform on the floors above and below.

5) Roto-elevator as in claim 2, **wherein** the aforesaid towers (13) are equipped at the top end of the static structure of the car silo with a ring (30) joining the said towers to a plurality of rollers (22) that are integral with the said static structure and arranged uniformly spaced on the outer circumference defined by the aforesaid tower (4a) in such a way as to guarantee the vertical stability of the tower (4a) itself.

6) Roto-elevator as in claim 3, **wherein** the aforesaid cantilevers (8 and 9) are grilled platforms.

7) Roto-elevator as in claim 1, **wherein** the aforesaid tower (4a) consists of a pair of vertical parallel bars (10) located opposite each other and fitted with opposite internal guides (20) within which the aforesaid elevator (5) runs, the said bars (10) being attached at their bottom ends (10a) to a base (11), which is coaxially equipped with the aforesaid drive means (6); the said bars (10) being also equipped with lateral supporting means (12) designed to secure them to the aforesaid cantilever platforms (8 and 9) in such a way that the latter are co-planar with the aforesaid floor (7).

5

10

15

20

25

30

35

40

45

50

55

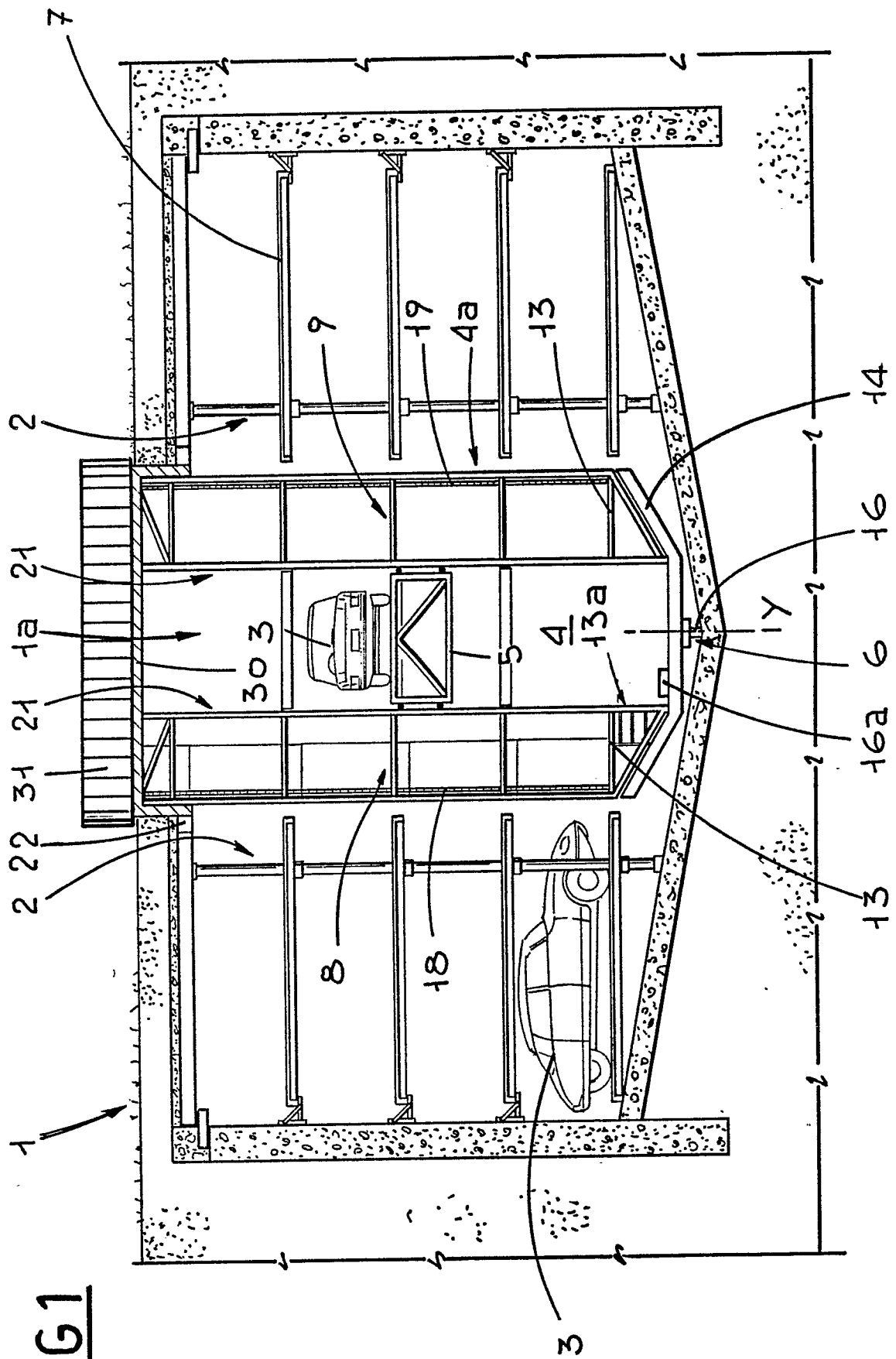

FIG 1

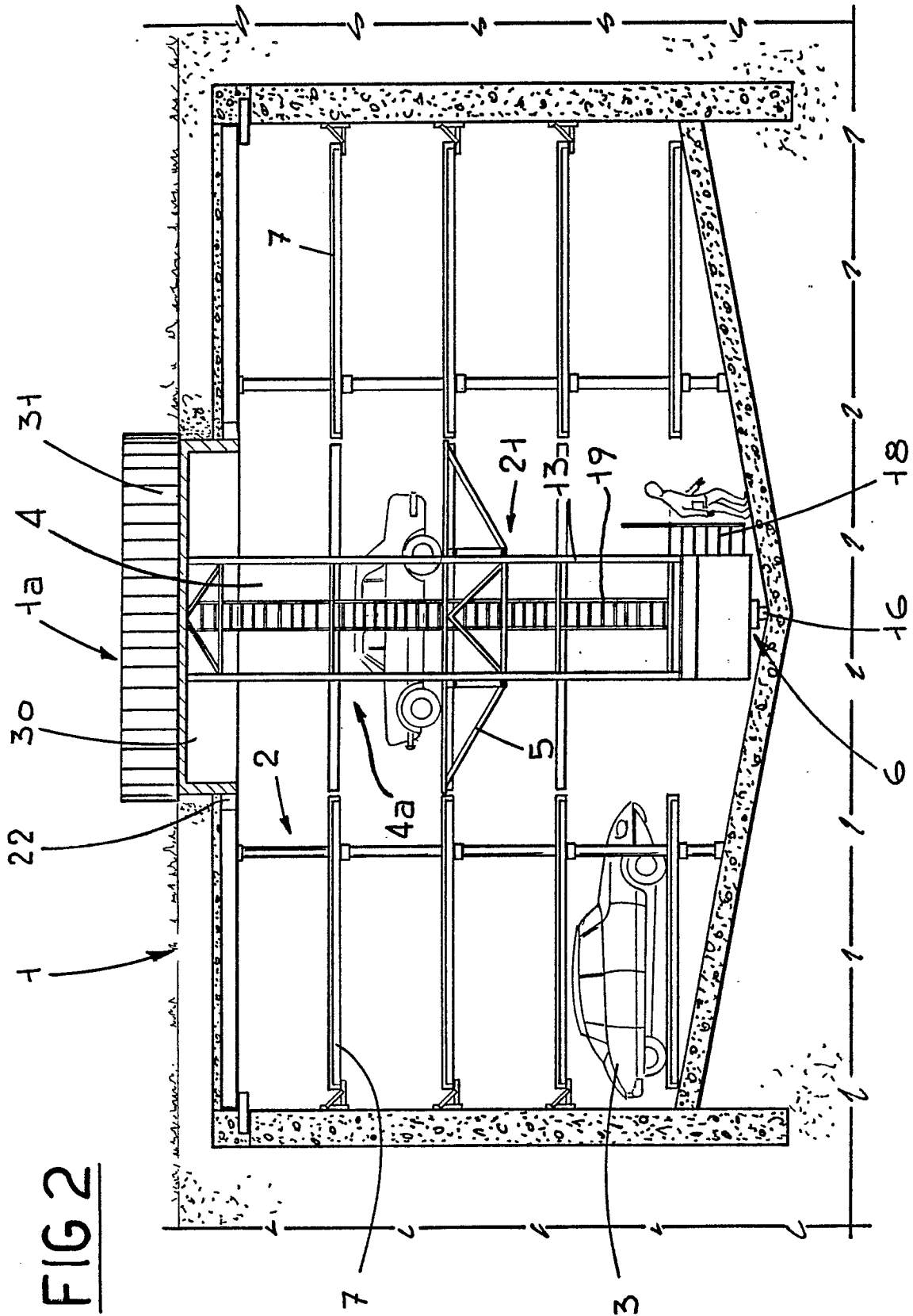

FIG 3

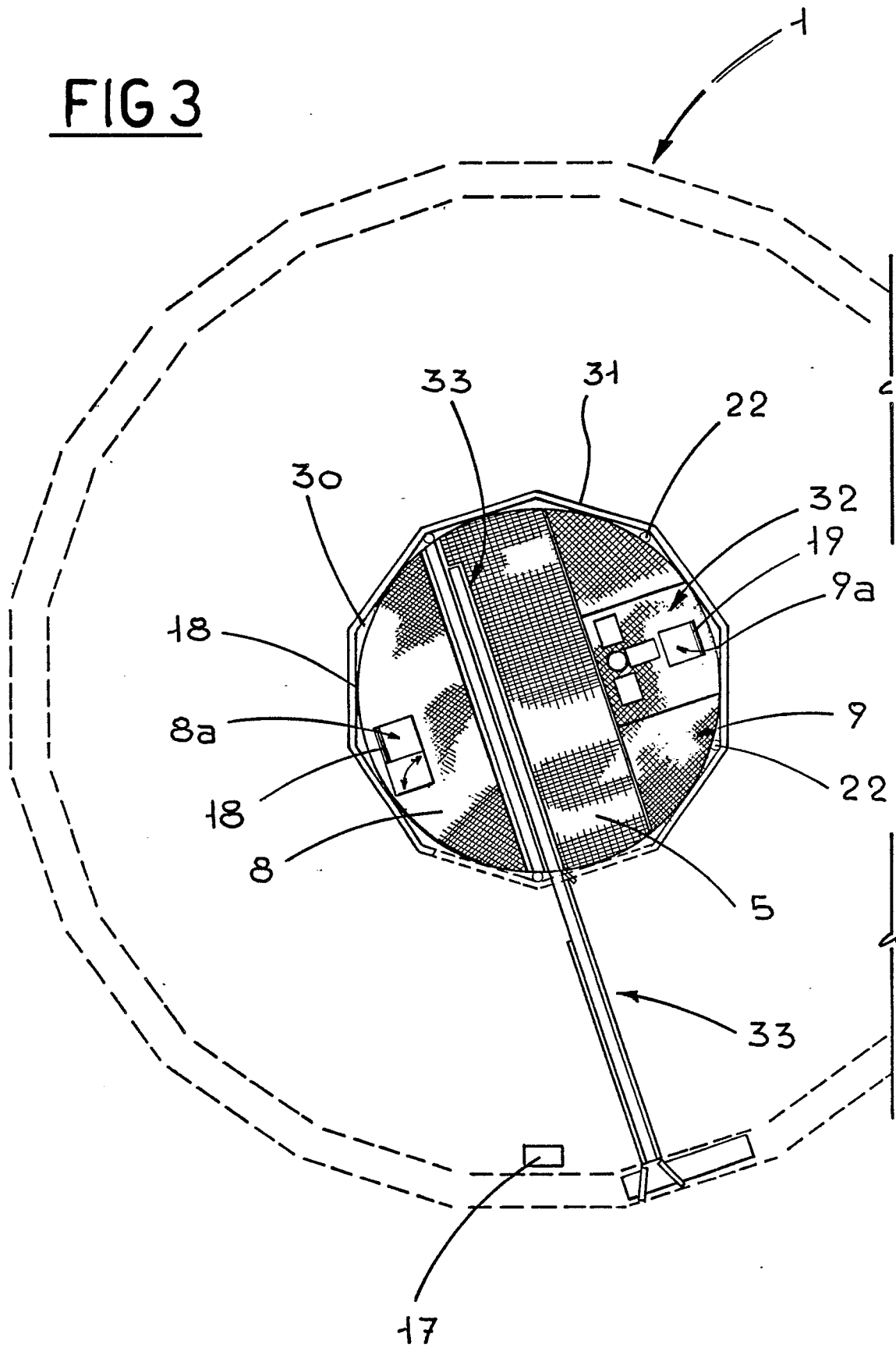

FIG 4

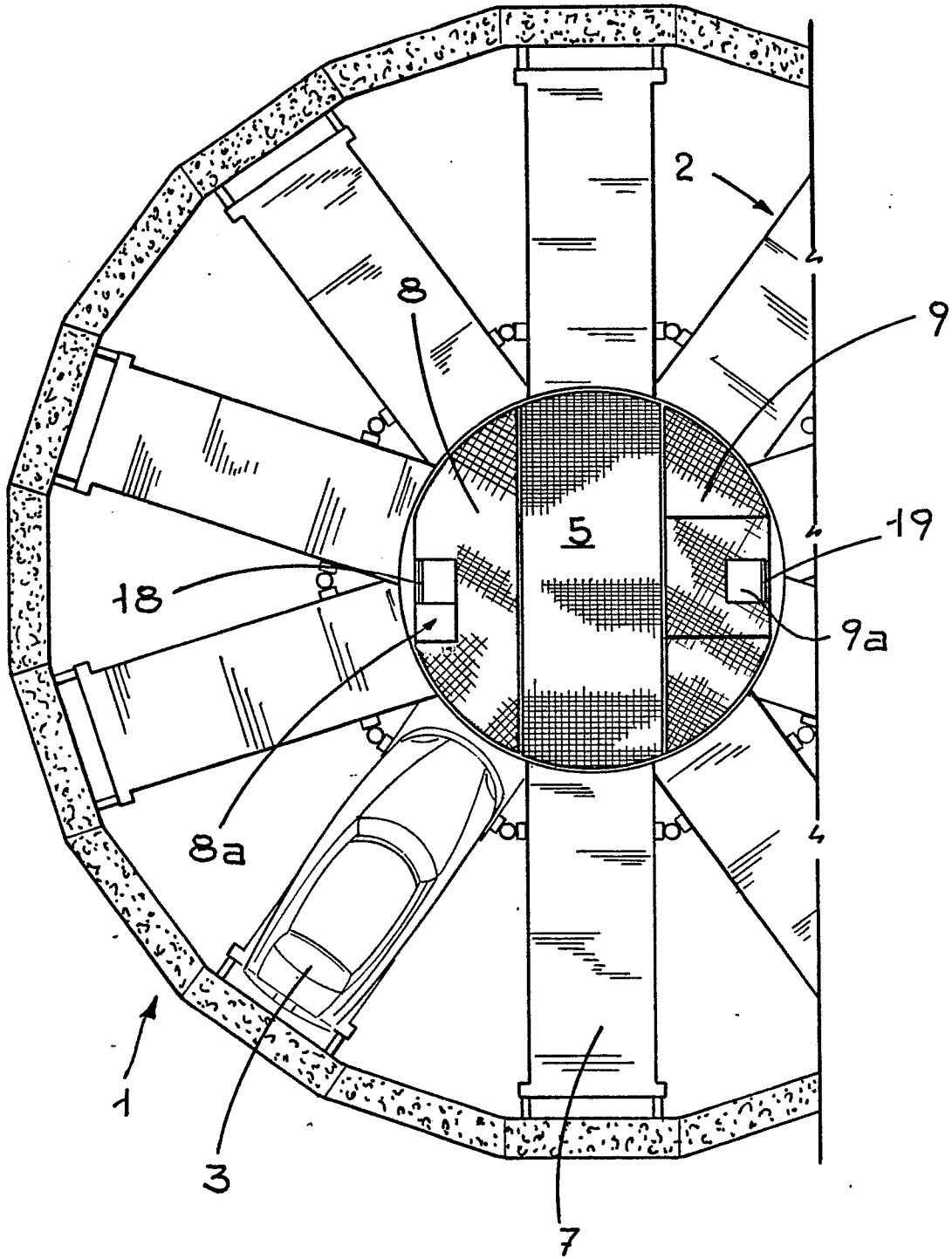

FIG 5

